

D30

# N79-17505

## Prosthetic EMC Control Enhancement Through the Application of Man - Machine Principles

W.A. Simcox  
Tufts University  
Medford, Mass.

J.G. Kreifeldt  
Tufts University  
Medford, Mass.

An area in medicine that appears suitable to man-machine principles is rehabilitation research, particularly when the motor aspects of the body are involved. If one considers the limb, whether functional or not, as the machine, the brain as the controller and the neuromuscular system as the man-machine interface, the human body is reduced to a man-machine system that can benefit from the principles behind such systems.

The area of rehabilitation that this paper deals with is that of an arm amputee and his prosthetic device. Reducing this area to its man-machine basics, the problem becomes one of attaining natural multiaxis prosthetic control using Electromyographic activity (EMG) as the means of communication between man and prosthesis.

In order to use EMG as the communication channel it must be amplified and processed to yield a high information signal suitable for control. The most common processing scheme employed is termed Mean Value Processing. This technique for extracting the useful EMG signal consists of a differential to single ended conversion to the surface activity followed by a rectification and smoothing as shown conceptually in Fig. 1.

Raw EMG is a complex bidirectional wave form, that if averaged over time yields a zero mean value. If constant muscle tension is to be maintained under a constant force isometric contraction the information content of the EMG describing the contraction should ideally be a constant DC voltage. If the bidirectional waveform results with a DC component produced. As the contraction level increases and decreases so will the mean value producing both a DC and low frequency component (1). The low pass filter is used to extract the mean value and low frequency components while attenuating the high frequencies present in the unidirectional waveform.

The output of the smoothing filter bears a monotonic relation to contraction effort in steady state. However, the output has a noise superimposed on it, similar to unrectified EMG, that increases with increasing contraction. A theoretical mode shows that this increasing noise must be the case for linear low pass filtering of rectified EMG (2).

The nature of this superimposed noise is shown in Fig. 2. The figure illustrates that rectification not only introduces the DC value but also a low frequency component and harmonics of that component. The use of the low pass filter to extract the DC value is clearly evident in the figure.

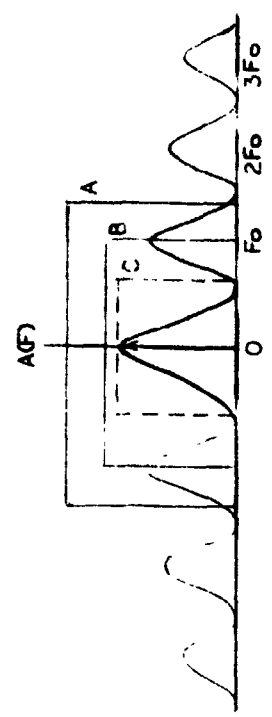

Figure 2 - Effects of Rectification on Myoelectric Activity. One way to reduce this noise is by decreasing the bandwidth of the filter which increases the amount of smoothing. But by doing this the system's step response deteriorates introducing a more pronounced exponential time lag leading to a sluggish system response. Control of sluggish systems is characteristically difficult for humans because of the time lag in the feedback of information between the user's control action and the system response.

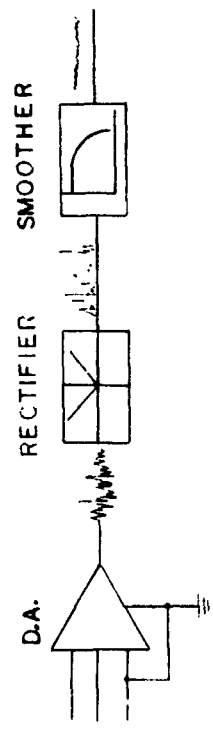

Figure 1 - Mean Value Processing.

Studies in controlling inherently sluggish system (3,4) suggest that a technique based on feedback of predicted as well as instantaneous device behavior allows these highly uncontrollable systems to be controlled quite easily. Studies indicate that control using this technique is highly natural in that very little training, attention and concentration is required to achieve the quality of control which would otherwise be very difficult or impossible. Therefore, the detrimental characteristic of sluggish response is prosthetic control caused by the large amount of smoothing needed to yield a high information EMG control signal can be greatly reduced if predictor feedback technology is introduced. It should be noted that predictor technology works best on sluggish systems that are used in a self-paced manner - a characteristic of EMG controlled devices with a high degree of smoothing of the activity. Thus the otherwise apparently detrimental characteristic to produce a "clean" EMG control signal becomes a key element for imperfection of predictor techniques in feedback control.

A research investigation was undertaken to determine the suitability of visual predictive feedback technology in controlling a simulated two axis assistance device. Specifically, two major hypothesis were addressed.

- 1) The work will provide basic information on a new approach to information feedback for EMG control of assistance devices. If this approach is successful as anticipated, the goal of simultaneous coordinated EMG control of a multi-degree-of-freedom device from several EMG activity sites will be much closer.
- 2) The application of predictor technology to EMG control may also cut through the apparent impasse of the smoothing - sluggishness relationship which governs simple EMG signal processing by utilizing this relationship as a beneficial rather than detrimental subsystem characteristic.

In addition to these two major hypotheses a subjective assessment of predictor technology for this specific type of control was addressed.

The dynamics of the artificial device used to develop the simulated predictor equations were obtained from the EMG controlled "Boston Arm", a prototype of which is located at the Liberty Mutual Research Center, Hopkinton, Massachusetts. The "Arm" is a single degree of freedom prostheses that can be controlled by above elbow amputees using electromyographic signals from the biceps and triceps. A block diagram of the "Arm" electronics is shown in Figure 3. The procedure for obtaining the dynamics was as follows:

Neglecting the preamplifiers, since a specific preprocessing technique was used, two input voltage steps of 1.5 and 2.5 volts were applied to the summer input. The response was obtained from the tachometer output yielding the system's impulse response. Figures 4 and 5 show the output velocity for the input steps introduced. The dynamics derived from the 1.5 volt step are used for the X direction with the derived dynamics from the 2.5 volt step used as the Y direction with the derived yielding a two-axis device dynamics. The figures suggest a simple arm model consisting of an integrate with an experimental time lag. The equation describing this simple model is:

$$\ddot{V}_o + b \dot{V}_o = a \dot{V}_{in} \quad (1)$$

where:

$$a = \begin{cases} .987 & \text{for 1.5 V input step} \\ .5.6 & \text{for 2.5 V input step} \end{cases}$$

$$b = \begin{cases} 1.48 & \text{for 1.5 V input step} \\ 5.6 & \text{for 2.5 V input step} \end{cases}$$

Equation (1) is the expression used to generate the predictor equations.

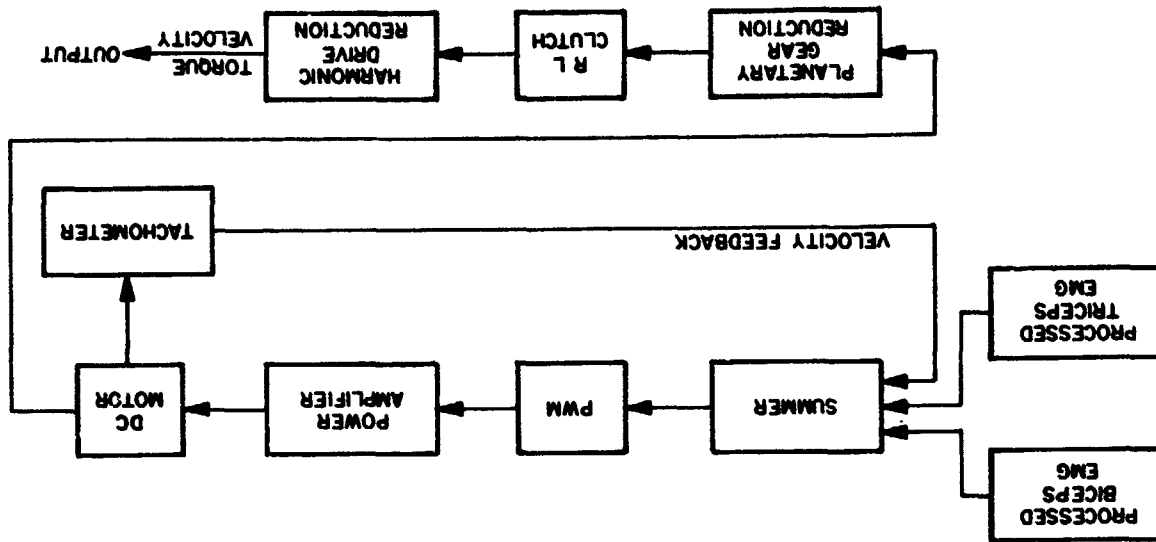

Figure 3 - Arm Block Diagram

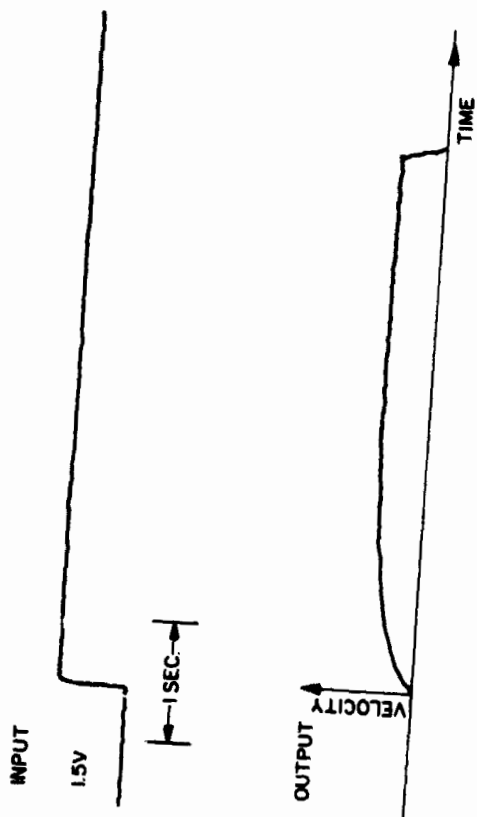
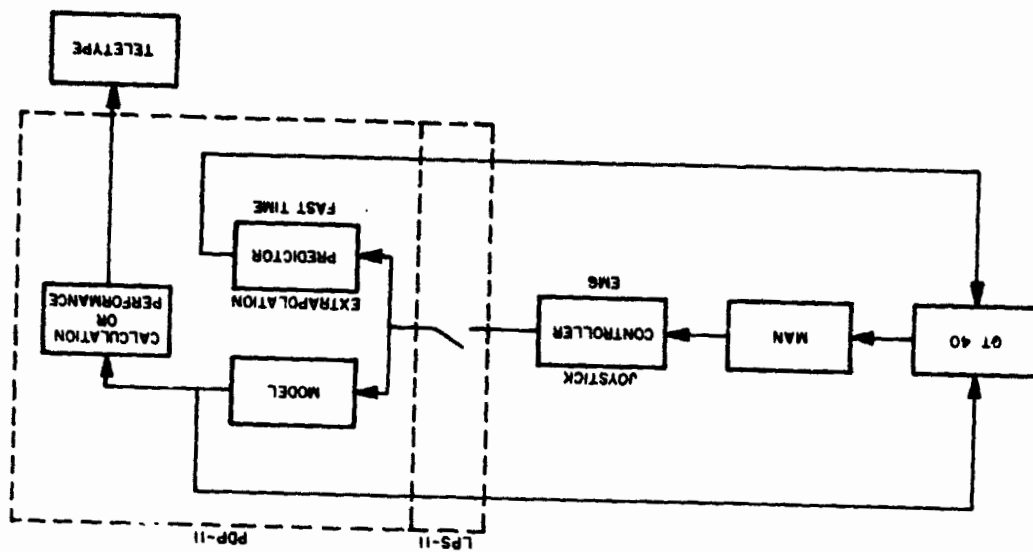

FIG. 4 OUTPUT FOR 1.5 V INPUT

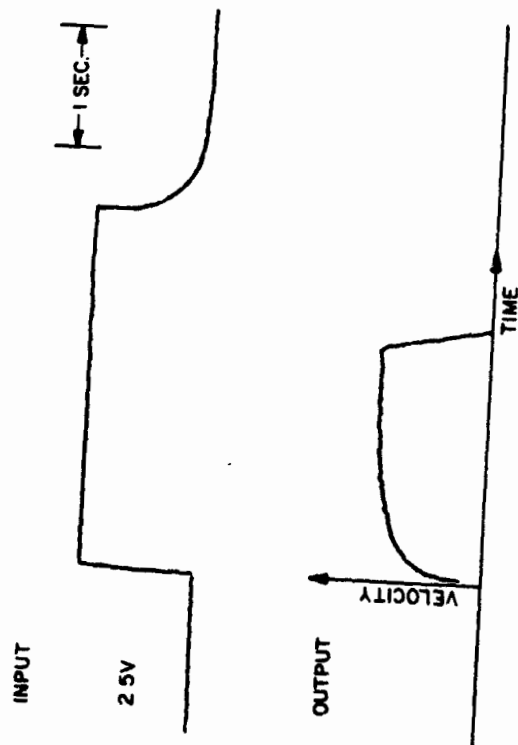

FIG. 5 OUTPUT FOR 2.5 V INPUT

The instrumentation used in the investigation consisted of an X-Y potentiometer joystick (Measurement Systems model 521), four EMG processors, a PDP-11 computer with an LPS-11 peripheral interface and GT-40 Graphics display (Digital Equipment Corporation).

The digital computer samples the EMG processor outputs, calculates the arm dynamic responses, the predictor information, calculates all the display elements and records the performance. A "BASIC" computer language program implements the software needed to perform these functions. Figure 6 shows a functional diagram of the experimental setup.

The task to perform was to move a cross representing the position of the "arm" in two dimensions, with or without its predicted path, through one of three sets of randomly presented mazes to a final circle as typified by figure 7.

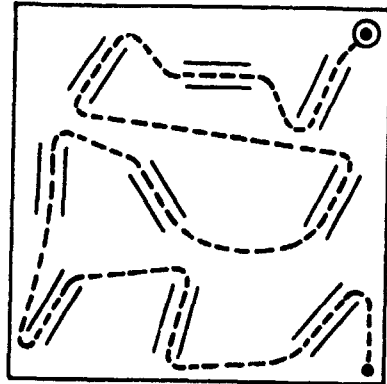

Figure 7 - Task Representatives

Each element of the maze was of equal length and width (1.59 x 1.09cm) and 6.3 cm apart from center to center. Only the randomly chosen orientation angles differed.

Subjects were instructed to move the cross as quickly and as accurately as possible going up the first column and down the second and third. If upon entering a channel the cross steps out of the boundary an error is recorded. At the end of each run the task completion time and task errors were recorded.

The combination of three prediction spans (P) of 0,1 and 2 seconds and two time constants (T) of 1 and 2 seconds made a total of 6 experimental conditions per subject. Two other experimental conditions, one using the joystick, a second prediction span and 2 second time constant, the other using the joystick, 1 second prediction span and 1 second time constant were also included to provide baseline values. Therefore each subject had a total of 8 conditions per day.

Six subjects (normal males between the ages of 22 and 28) took part in the final testing phase using the following procedure. Electrodes were placed on the biceps and triceps of both arms. The right bicep controlled the +x direction while the right tricep controlled the -x direction. The left bicep controlled the +y direction and the left tricep controlled the -y direction. The subjects were presented with a randomly chosen control combination of prediction span, time constant and EMG or joystick and given five runs of each. The task completion time and errors were then recorded for the final two runs of each of the eight control combinations. In addition a special purpose circuit was constructed to measure the degree of simultaneous control. Upon completion of the experiment a short questionnaire was filled out by each subject.

Table I presents the data for the variables in this experiment, and Table II provides an analysis of variances found.

TABLE I

SOURCE	Task Completion Time (sec.)		Task Errors	
	MEAN m	STD. DEV.	MEAN m	STD. DEV.
1 SEC. SMOOTHING ( $\tau_1$ )	157.72	112.98	6.83	4.88
2 SEC. SMOOTHING ( $\tau_2$ )	205.64	125.38	7.22	6.17
PREDICTOR OFF ( $P_0$ )	282.17	116.03	12.08	6.55
1 SEC. PRED. ( $P_1$ )	114.23	61.05	4.33	2.02
2 SEC. PRED. ( $P_2$ )	128.19	65.84	4.66	2.76
SUBJECT 1	216.00	182.36	11.17	8.03
SUBJECT 2	194.75	64.31	8.17	3.09
SUBJECT 3	140.58	67.05	5.58	4.26
SUBJECT 4	203.92	85.23	6.92	4.92
SUBJECT 5	144.85	60.51	3.75	2.31
SUBJECT 6	189.50	74.99	6.58	5.69

TASK COMPLETION TIME

SOURCE	DOF	SS	MS	F	%MS
PREDICTION SPAN (P)	2	367259	183629	17.3	39.4%
SMOOTHING (T)	1	41712	41712	8.8	5.3%
SUBJECT (S)	5	59247	11849	8.6	9.2%
PXT	2	39079	19539	2.5	5.7%
PXS	10	106250	10625	7.9	12.4%
TXS	5	23614	4723	3.5	3.5%
PXTXS	10	76852	7685	5.7	17%
WITHIN ERROR	35	47249	1350		7.5%
TOTAL	70	761265			

Table II

1) Task Completion Time: From Table I the task completion time increased with the smoothing time constant (p < .05) but inspection of figure 8 indicates that when using the predictor, completion time is independent of the amount of smoothing. Without the predictor however, there is a 42% increase in task completion time for the more sluggish time constant which is to be expected. It has been shown that a two second time constant increases the signal to noise ratio approximately 90% over the one second time constant but the system settling time increases causing a sluggish system response. The use of the predictor completely offsets this problem.

Inspection of figure 6 indicates another very important result. In all cases using EMS control with the predictor, task completion times are lower than joystick or hand control using no predictor. It must be noted that the control combinations using the joystick were approximate estimates of best and worst conditions. Given this result a set of posteriori tests of means were performed using Duncan's multiple range statistic.

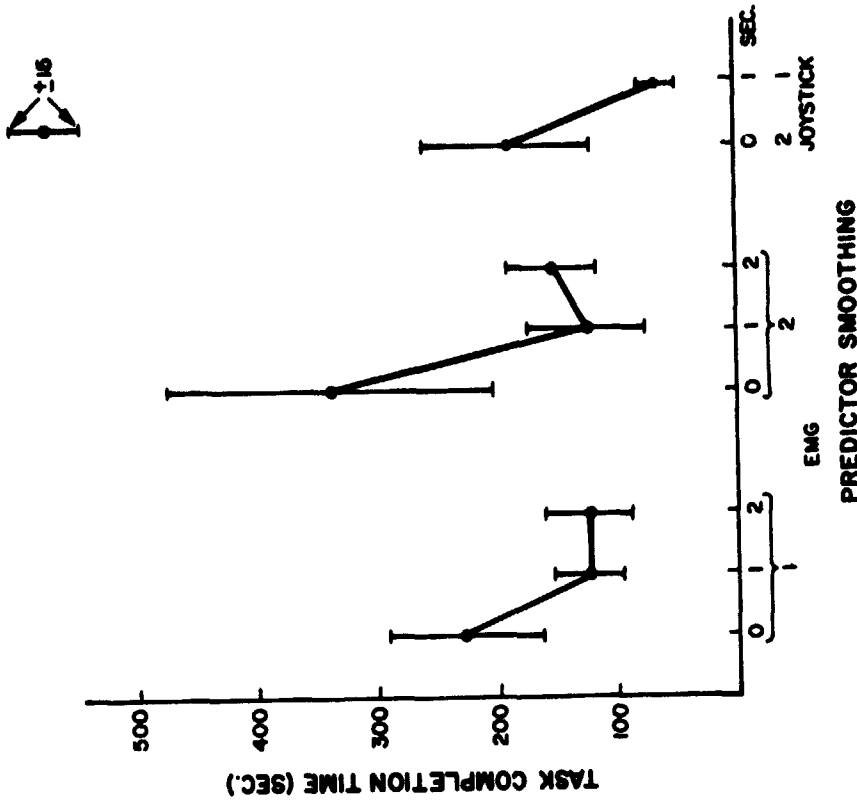

Figure 8 - Completion Time vs Experimental Variables

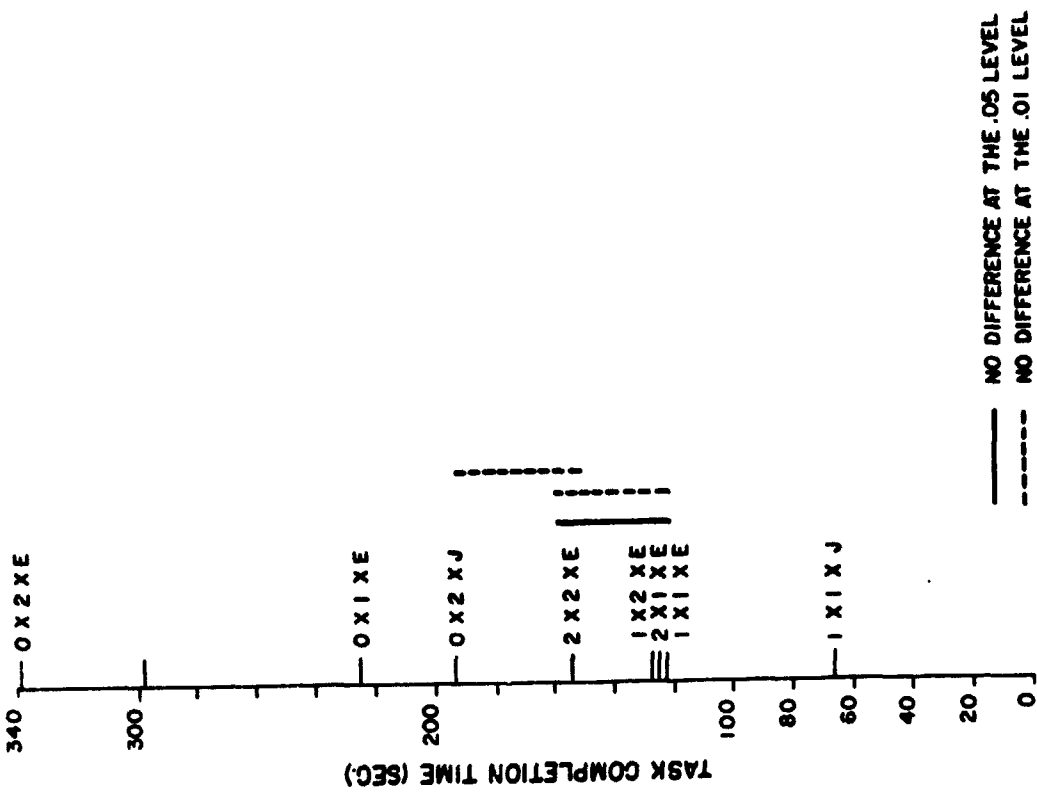

Figure 9 - Analysis of Means of Task Completion Time vs Experimental Variables

The results of these tests indicate which means are significantly different from the rest of the group. The analysis of means of figure 9 is plotted in figure 9. The results of these comparisons are indicated by the solid and dashed lines in the figure. Each member of a group of means that lies under the solid or dashed lines cannot be considered as significantly different from every other member of that group at the 5 and 1 percent levels respectively. Figure 9 shows that there is no significant difference in EMG control combinations using the predictor but there are control combinations are significantly different from the no predictor case and joystick control.

Figure 10 shows task completion time versus subjects with the different combinations of predictor. There is a significant interaction between subjects and predictors but one result is apparent. All subjects task completion times were lower when using the predictor over no predictor.

Task Errors: Task errors and task completion times are fairly dependent measures of one another ( $r=0.81$ ), therefore results of one predicts the results of the other.

After completing the experiment, the subjects were asked to answer 7 questions. The results of the most important of these questions are briefly discussed below.

The subjects were first asked to what degree was the predictor used. All subjects used it more than half the time while three responded they used it all the time.

In the second question, the subjects expressed what they liked about the predictor. All subjects indicated that the predictor helped them maintain the right direction and orientation. One subject indicated that the predictor gave him a feeling of velocity. Another subject stated that the predictor allowed him to line up the cross as he approached a channel of the maze instead of "waiting" one muscle at a time. The subject response indicates a more coordinated simultaneous control using the predictor.

Subjects expressed their dislikes about the predictor in the third question. Most subjects felt the larger prediction spans were more distracting than the shorter although objectively there was no significant difference in the spans. Subjects also expressed a dislike to the system lag time when using no predictor.

The fourth question was designed to enquire as to the strategy exhibited in using the predictor. All subjects responded that they coordinated their muscle activity to line up the predictor and "shoot" it through each channel of the maze.

The fifth question was designed to find out if the subjects felt they used less muscle contraction in completing the task with the predictor. All responded that the task was accomplished with less contractions although graphs of integrated EMG taken concurrently with the task indicate that this is not the case. The perceived response of less contraction may have been stated with respect to overall task time which took longer with no predictor.

In addition to the task time, task error and questionnaire data, some method of recording simultaneous EMG control was needed. The circuit of figure 11 was used. Raw EMG signals from both sets of control wires are added and multiplied together. This multiplied output, which represents the EMG combination from both arms, is used to trigger the comparator whose output is monitored by a chart recorder. (MTE Model CP-2).

Therefore if a discrete type of control approach is used (movement in one direction first followed by movement in the other) the comparator output is zero. If a combinational approach is used (moving in both directions together) the comparator output becomes one. Therefore, the degree of simultaneous control is measured by the number of ones at the comparator output. Figure 17 shows the degree of simultaneous control versus the three predictor conditions. Simultaneous control occurred 46% of the time using no predictor. With the 1 second prediction span, simultaneous control was achieved 73% of the time, an increase of 60%. Using the 2 second predictor resulted in a 53% increase in control.

There is sufficient information from the analysis of the data to state the following conclusions.

- 1) DMG Control with the predictor feedback resulted in substantially reduced task completion time (on the order of 100% (p .05)).

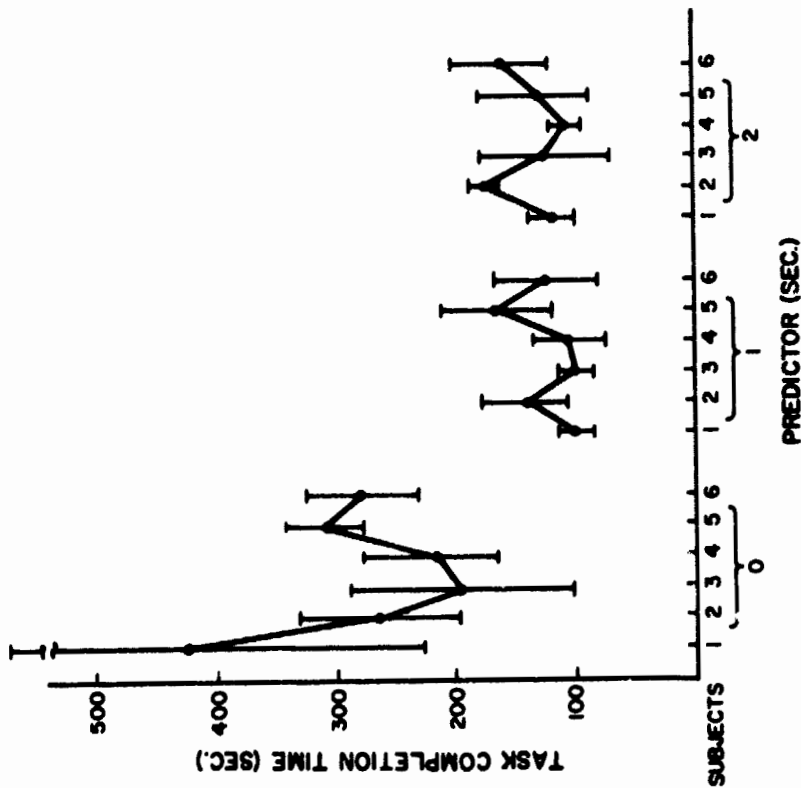

Figure 10 - Completion Times vs. Subject Predictor Interaction

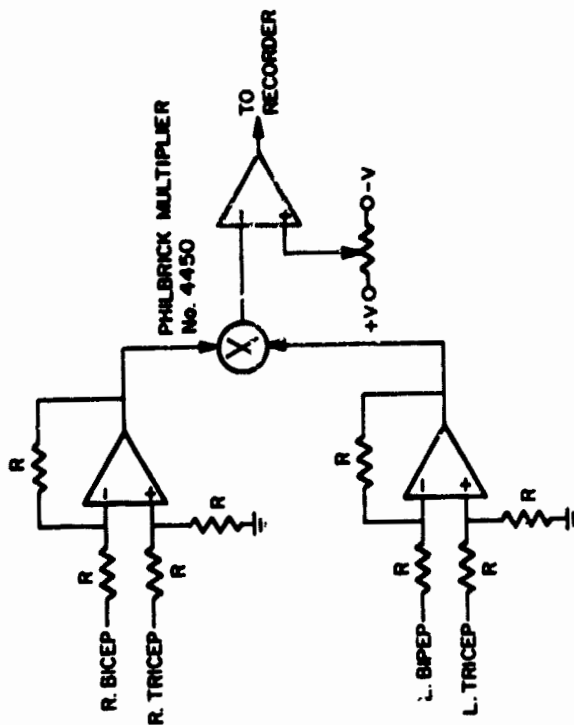

Figure 11 - Circuit used to Measure Degree of Simultaneous Control

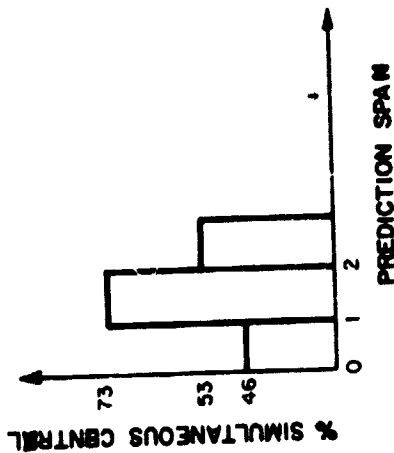

Figure 12 - % Simultaneous Control vs Prediction Span

2) Task completion time and task errors are independent of the amount of filter smoothing when using predictor feedback. When no predictor information feedback is used, task completion time increased by 40% when the task time was doubled. It appears that increased SMP can be attained at control levels not approached in the past.

3) Manual control with a joystick and no predictor feedback was inferior to EMG control with predictor feedback.

4) Using predictor feedback substantially reduces the variance in performance permitting re-evaluations.

5) Predictor information feedback allows for more simultaneous coordinated EMG control leading to a smooth multi-axis system response.

6) The same subject, predictor interaction indicates that prediction spans could be "tailored" for each subject as needed.

The results of this investigation indicate that in treating the human as a man machine system it is possible to benefit from principles behind such systems. It also provides a basis for the beginning of these principles in other areas of Rehabilitation Research.

1. Krefeldt, J.: "Signal Versus Noise Characteristics of Filtered EMG Used as a Control Source." IEEE Transactions on Biomedical Engineering, Vol. 18 No. 1

2. Krefeldt, J.: "EMG as Amplitude Modulated Noise", Cybernetic Systems Group, Engineering Design Center Case Western Reserve University, Cleveland, Ohio, Memo 1968.

3. Kelly, C.: "Predictor Displays-Better Control for Complex Manual Systems" Control Engineering, Aug. 1967

4. Warner, J.: "A Fundamental Study of Predictive Display Systems." NASA Contract Report NASA CR-1274, Feb. 1969.