

D14

N79-17489

REDUCED MENTAL CAPACITY AND BEHAVIOR OF A RIDER OF A BICYCLE SIMULATOR UNDER ALCOHOL STRESS OR UNDER DUAL TASK LOAD

Mathijs Soede  
Netherlands Institute for Preventive Medicine  
Health Organization TNO  
Wassenaarseweg 56  
Leiden Netherlands

In mental load studies most research is done with tasks requiring much attention. Concurrent tasks or drugs will decrement the performance in those situations immediately. It is expected that different results will be obtained in tasks performed as an overlearned reflex. In previously described bicycle simulator experiments both aspects are combined, i.e., the course-following task is supposed to be an attention-demanding task and the balancing of the bicycle is supposed to be an overlearned routine task for most Dutch people. Experiments were carried out on this simulator with alcohol administration and a binary choice task in separate sessions, intending to reduce the subject's mental capacity. Before and after such sessions a visual evoked response measurement was done. The subject's performance was analyzed with describing function techniques. Details of this technique using two forcing functions to analyze the two dimensional task are given in other papers (Van Lunteren). The results indicate that the alcohol affects the course-following task as well as the balancing task: i.e., a general effect. The binary choice task is more specifically influencing the course-following task. The dual task shows a more pronounced effect on the recovery of the evoked response. The alcohol is delaying the recovery curve of the evoked response. A tentative explanation can be given which agrees with the performance data.

REDUCED MENTAL CAPACITY AND THE BEHAVIOR OF A RIDER OF A BICYCLE SIMULATOR UNDER ALCOHOL STRESS OR UNDER DUAL TASK LOAD

Mathijs Soede  
Netherlands Institute for Preventive Medicine  
Wassenaarseweg 56  
Leiden  
Netherlands

0 SUMMARY

In mental load studies most research is done with tasks requiring much attention. Concurrent tasks or drugs will decrement the performance in those situations immediately. It is expected that different results will be obtained in tasks performed as an overlearned reflex. In previously described bicycle simulator experiments both aspects are combined, i.e., the course following task is supposed to be an attention-demanding task and the balancing of the bicycle is supposed to be an overlearned routine task for most Dutch people. Experiments were carried out on this simulator with either alcohol administration or a binary choice task in separate sessions, intending to reduce the subject's mental capacity. Before and after such sessions a visual evoked response measurement was done. The subject's performance was analyzed with describing function techniques. Details of this technique using two forcing functions to analyze the two dimensional simulator task are given in other papers (Van Lunteren). The results indicate that the alcohol affects the course following task as well as the balancing task: i.e. a general effect. The binary choice task is more specifically influencing the course following task. The dual task shows a more pronounced effect on the recovery of the evoked response. The alcohol is delaying the recovery curve of the evoked response. A tentative explanation can be given which agrees with the performance data.

1 INTRODUCTION

Most of the research in mental load and mental capacity is done with the aim of protecting the subject from overloading which can result in a decrement of performance or an increase in errors. An important concept in this research is the reserve capacity. Some methods are known to estimate this reserve capacity; although none of these methods is enough reliable and valid, under certain conditions it is possible to give rough estimates of the mental load or its complement, the reserve capacity (Ref.1). Research done with concurrent tasks, is in general set up from the viewpoint of strategies for allocation of attention. In this case there is no overloading of the subject and the investigator is not interested in the level of load imposed upon the subject. Another application of a concurrent task is the use of a distraction task. In this case the presumption of a limited mental capacity is based on the fact that the primary task performance can be altered or disturbed by the

distraction task.

It is not always possible to explain the changed performance or the errors in task performance by a single channel theory (Ref.2). It is more acceptable that the handling of information, i.e. performance of tasks by the human operator can be done in two different ways, either in an automatic way, based on routine, or in a conscious way requiring much attention. This means, respectively, a performance produced by hierarchical lower control systems or at the level of the central nervous system.

In this paper a pilot experiment is described in which a task is considered to be performed using control at various levels of the nervous system. This task is the stabilization of, and course following on a bicycle simulator respectively considered as a routine aspect and an attention demanding aspect of riding a bicycle. The presumption that reduction of the subject's mental capacity (i.e. at the level of the central nervous system) will cause altered performance is the basic issue of this paper.

Different causes of reduced capacity occur in practice, for instance illness, distraction, age, drug- and physical handicaps requiring extra attention to compensate for the handicap.

Two different sources of reduction are given in the experiments described in this paper i.e. the performance of a binary choice task as a distraction-task and the administration of alcohol supposing to give, among other effects, a reduction of the mental capacity.

The purpose of this research can be formulated as follows:

- to what extent is the reduction in capacity compensated for by altered strategies in task performance.
- what are the similarities and differences between capacity reduction by distraction (binary choices) and by a specific drug i.e. alcohol.

Besides these purposes the application of describing function techniques in a two dimensional cross coupled control task was of interest. A frequently proposed method of estimating mental load is based on physiological measures like heart rate variability, blood pressure, galvanic skin response and EEG. Therefore in the reported experiments some of these variables have been measured.

Before reporting the experiments, section 2 will give some general remarks about capacity and capacity reduction to give more insight in problems connected with this type of research.

## 2 ASPECTS OF CAPACITY AND CAPACITY REDUCTION

In literature the concept of mental capacity is defined in different ways. Firstly there is no agreement about the unit for mental activity. Examples are the bit of information or the element of a task.

Secondly it appears that different definitions of capacity are given due to insufficient knowledge of dynamic and stochastic aspects of mental capacity.

A frequently used, operational definition of capacity is one whereby the task load is expressed  $r$ , the number of choices per unit of time. In this case the maximum capacity is sometimes defined as the maximum task load (number of choices), which can be maintained for a certain duration (Ref.3). A graph of the task load at different durations is given in Fig.1. The momentary capacity is not equal to the capacity as given by the definition mentioned above and illustrated in Fig. 1.

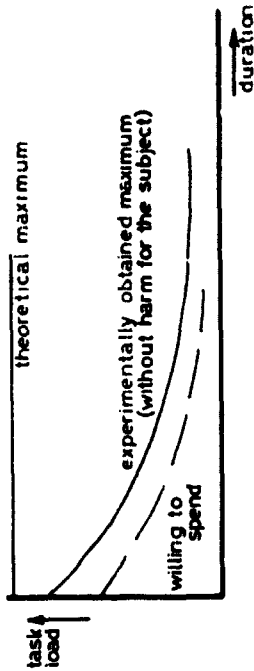

Fig. 1 The relation between a constant task load and duration of performance.

The dynamic aspect of mental capacity implies that the momentary capacity is dependent on the previously used capacity and recovery characteristics of the subject. There is not enough knowledge about this aspect to propose a model for this phenomenon.

The stochastic aspects of capacity are the fluctuations in capacity due to, for instance, variations in external influences, momentary condition and motivation of the human being.

This means that differences in capacity have to be expected between different persons and at different moments for the same person. Based on these considerations the following has to be stated with respect to those experiments where capacity is an important notion.

- One has to control the duration of the task runs accurately to prevent different effects from the dynamic aspects of capacity.
- For the same reason the rest periods between test runs has to be controlled.
- Randomization of the sequence of different experimental conditions is advised to account for the effects of the stochastic aspects of capacity.
- More complicated is the situation when the subject's capacity is not filled up with the task load, this means a difference between the capacity held available by the subject and the capacity used for performing the task.

The decision to acquire some physiological measures in the reported experiments is based on the last remark because these measures are supposed to be related with the amount of available capacity (Ref 4,5,6).

## 3 DESCRIPTION OF EXPERIMENTS

### 3.1 THE BICYCLE SIMULATOR

An extensive description of the bicycle simulator is given in earlier publications (Ref.7). The main parts of the simulator are the following (Fig.2).

- Bicycle frame with roll possibility and rotating handle bar.
- Torsion motor to stabilize the bicycle frame
- Display system to indicate the simulated course; this system has been built with a rotating projector behind the bicycle frame and a projection screen at a distance of 2 meters in front of the bicycle frame.

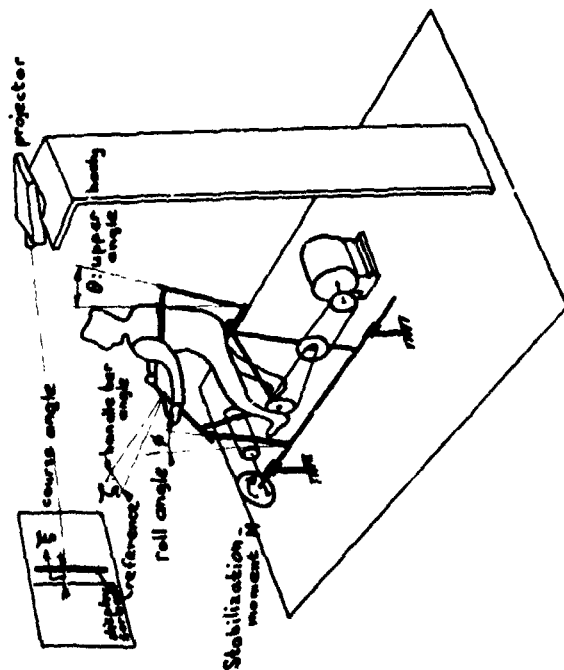

Fig. 2 A schematic drawing of the bicycle simulator and some important signals

The course is given by a vertical projected line on the screen which has a fixed reference line in the middle.

- Electric and electronic equipment to simulate forward speed, to control the torsion motor and to control the turn table of the projector.

The inputs for this system are frame roll angle, handle bar angle and a preset value indicating the forward speed (the simulator is operated as a moped).

Provisors are made to measure upper body angle and other important signals.

A block diagram is given in Fig. 3. This block diagram also presents the elements of the describing function of the human operator: i.e. the transfer functions  $N_{1H4}$ .

It is clear from this block diagram that the cross coupling of elements in the simulator give the possibility to stabilize with handle bar rotation or with upper body movements. This gives rise to the element  $N_2$  in the

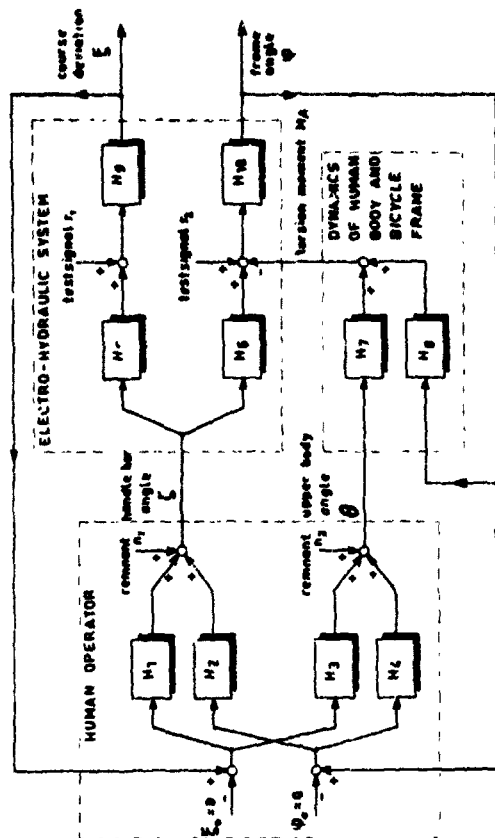

Fig. 3 A block diagram of the man-bicycle system including a cross-coupled course following system and a stabilization system.

describing function. It is not possible to follow the course by upper body motions. However, interferences in body movements and arm movements resulting in handle bar rotations will probably cause a relation between roll angle and handle bar angle. Therefore the element  $N_2$  is proposed to describe this possible relation. The forcing functions  $r_1$  and  $r_2$  simulate respectively a course and the effect of side-wind on the man-bicycle system. The simulator gives a reasonable resemblance with the real situation. The missing of wind and longitudinal movement are not very important. The different direction of the acceleration on the human body gave some troubles in the first training sessions, however the trained subjects were not troubled with this phenomenon.

### 3.2 SET-UP OF THE EXPERIMENTS

The experiments consisted of three series of measurements each during a morning from 8.00 a.m. to 1.00 p.m. At the first morning an additional binary choice task was given to the subject performing the bicycle task. The second morning was appointed for bicycle riding with alcohol. The last morning was intended to be a reference measurement to compensate for

### 3.4 THE ALCOHOL ADMINISTRATION

At the second day of experiments the subject was given a drink with alcohol resulting in blood alcohol concentrations as given in Fig. 5.

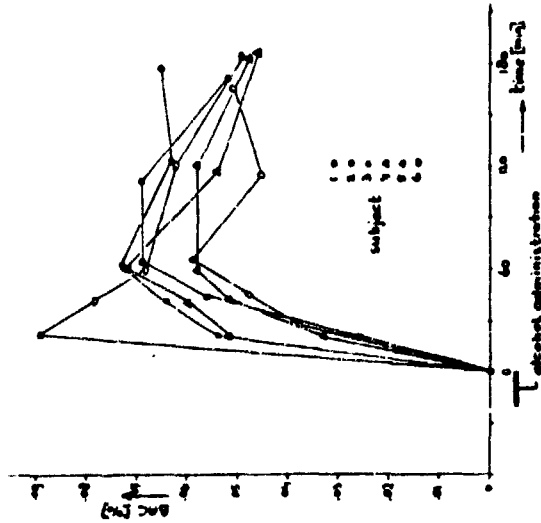

Fig. 5 The individual blood alcohol curves.

The alcohol administration occurred just after the first test run. The blood alcohol concentrations were determined by means of venous punctures at selected moments between the test runs. To account for emotional effects caused by the venous puncture, blood samples were taken each day.

### 4 METHODS OF ANALYSIS

#### 4.1 ANALYSIS OF PERFORMANCE ON THE BICYCLE SIMULATOR

The model chosen for the behavior of the rider of the simulator consists of four elements i.e. the describing functions of the relations between the following signals:

- H<sub>1</sub>: course angle  $\zeta$  and handle bar angle  $\tau$
- H<sub>2</sub>: roll angle  $\phi$  and handle bar, angle  $\tau$
- H<sub>3</sub>: course angle  $\zeta$  and upperbody angle  $\theta$
- H<sub>4</sub>: roll angle  $\phi$  and upperbody angle  $\theta$

diurnal rhythms. The division of the day is given in Fig. 4 and shows that four task measurements were made each day.

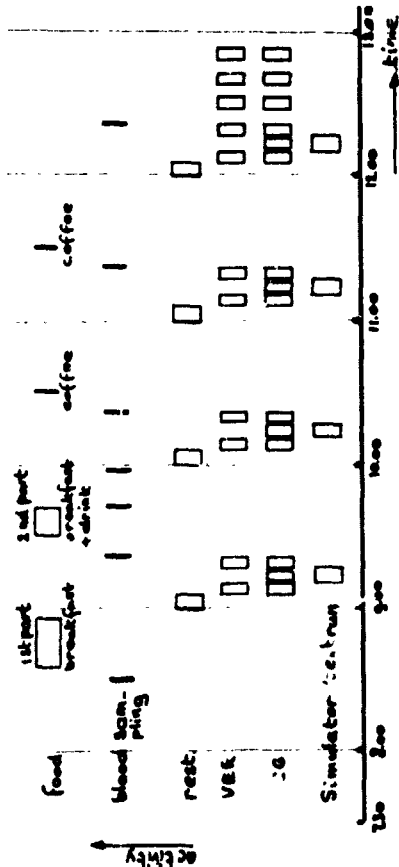

Fig. 4 The time schedule of a day of experiments.

The first measurement on the day was always without distraction task or alcohol. The electrocardiogram was measured before, during and immediately after a simulator test run.

The visual evoked response was measured together with the corresponding ECG measurements only before and after task performance. The latter measurements were taken in a separate ECG-room. The subjects were 6 male students. A medical examination was carried out beforehand. The subjects were asked not to use alcohol during the week of the experiments. The training on the bicycle simulator and on the binary choice task consisted of six hours divided over a three days period. All subjects had much experience with normal bicycle riding.

### 3.3 THE BINARY CHOICE TASK

Distraction was caused by a binary choice task (Ref. 8). The task stimulus consisted of a randomly generated high or low tone, pre-empted with headphones to the subjects. These tones had to be answered by operating a microswitch with respectively the right and left hand. The microswitches were mounted in a convenient place on the handle bar of the bicycle. The number of choices given at the first day of experiments was fixed at 0,45, 30 and 15 per minute in the first, second, third and last test run on that day respectively.

The technique for estimating the parameters in this model is given elsewhere (Ref. 9, 10), therefore only a summary is given here. The two forcing functions used, consist each of a sum of ten sinusoids, having a flat amplitude spectrum and an overall repetition time of 4 minutes. Due to the necessity of decoupling the signals in the system with respect to each of the forcing functions, the frequencies in each of the forcing functions have to be different. Therefore the frequencies are chosen in pairs closely together. The situation shown in Fig. 6 is the situation with decoupled signals i.e.  $\phi(\nu)$ ,  $\xi(\nu)$ ,  $\zeta(\nu)$ , and  $\theta(\nu)$ . ( $\nu$  is the frequency in Hz).

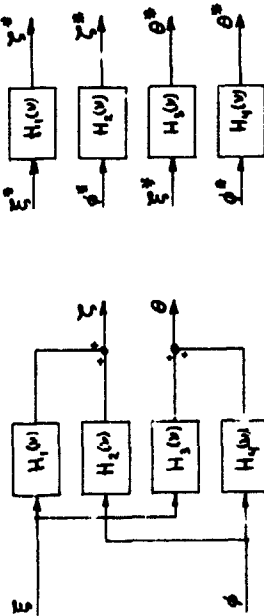

Fig. 6 The describing function model of the human operator before and after decoupling of the signals.

Some derivation leads to the following expression:

$$\xi^*(\nu) = \zeta_1(\nu) - \frac{\zeta_2(\nu)}{\phi_2(\nu)} \phi_1(\nu) \quad (1)$$

The signals are split up with respect to the forcing functions  $r_1(\nu)$  and  $r_2(\nu)$ . The indices in Eq. (1) relate to the indices of the forcing functions. At a frequency  $\nu_k$  of a sinus component of test signal  $r_1(\nu)$ , it turns out that  $\zeta_2(\nu_k) = \phi_2(\nu_k) = 0$  at that particular frequency. Assuming that the transfer functions are sufficiently smooth, it can be stated that if  $\Delta\nu$  is small:

$$\frac{\zeta_2(\nu_k)}{\phi_2(\nu_k)} \approx \frac{\zeta_2(\nu_k + \Delta\nu_k)}{\phi_2(\nu_k + \Delta\nu_k)} \quad (2)$$

Due to the fact that the frequencies of the test signals are chosen closely together, Eq. (2) can be substituted in Eq. (1), and thus Eq. (1) can be solved. Equivalent expressions can be derived for signals  $\theta^*(\nu)$ ,  $\phi^*(\nu)$  and  $\xi^*(\nu)$ . The choice of the best structure of the model is difficult due to the cross-coupling of signals in the simulator system as well as in the human operator. Therefore different structures were used and the results were compared with respect to the quality of the fit of the model to the measured data points. Based on this comparison the following structure is proposed:

$$H_1(\nu) = K_1 (1 + 2\pi j\nu T_{11}) e^{-2\pi j\nu T_{11}} \quad (3)$$

$$H_2(\nu) = K_2 e^{-2\pi j\nu T_{21}} \quad (4)$$

$$H_3(\nu) = K_3 (1 + 2\pi j\nu T_{13}) e^{-2\pi j\nu T_{13}} \quad (5)$$

$$H_4(\nu) = K_4 (1 + 2\pi j\nu T_{14}) e^{-2\pi j\nu T_{14}} \quad (6)$$

It appears that the complete model has 11 parameters.

To study group effects of alcohol or binary choices on human performances in this set-up, one can consider the averages of the estimated parameters. It is preferable to do the parameter estimation on the average of the raw signals (see also section 5).

An average of two measurements can be taken if the frequencies of the forcing functions in the signals have the same phase in both measurements. In general this is not the case, therefore the different signal components have to be aligned.

This is illustrated in Fig. 7 for the time domain representation.

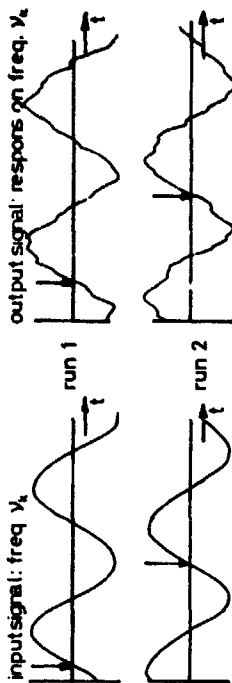

Fig. 7 Illustration of the averaging procedure for one frequency in a signal considered.

In the frequency domain it means a rotation of the vectors representing the Fourier coefficients of the sinusoidal components.

Various averages are made as will be shown in section 5.

#### 4.2 ANALYSIS OF PHYSIOLOGICAL DATA

From the electrocardiogram the following measures were obtained (Ref. 11).

- Heart rate [beats/minute].
- Standard deviation of the beat to beat duration (RR-intervals) [msec].
- Sum of positive differences of intervals S divided by the number of reversals in increasing or decreasing intervals N: S/N [msec].

These frequently used measures were obtained for a number of periods as shown in Figure 4. All measurements are referred to the first measurement on an experimental day, thus showing a decrease or increase as a percentage of the first value.

The evoked responses could only be recorded just before and after a simulator test run (See Figure 4). The most important parameter in the evoked response is considered to be the amplitude of the so called top IV. (Ref. 5).

ORIGINAL PAGE IS  
OF POOR QUALITY

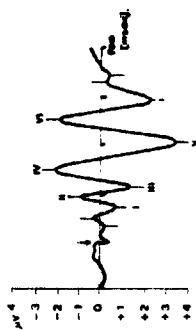

Figure 8. An example of a visual evoked response

Fig. 8 gives an example of an averaged visual evoked response. The analysis includes the averaging of single evoked responses, smoothing of the average, normalising the individual averages, pooling of the individual averages and calculating the amplitude of top IV.

## 5 RESULTS

### 5.1 THE PERFORMANCE DATA

The estimated parameters based on individual measurements of the four test runs and of the six subjects showed a large variance. Due to this fact no significant differences between conditions could be determined. A better result was gained after averaging the raw signals for the second, third and fourth test run on a day.

This means that three comparable measurements were taken together: i.e. three test runs with a distraction, three test runs with a blood alcohol concentration (BAC) of .05% and three test runs on the reference day of single bicycle task measurements. It is obvious that the averaging of test runs with different BAC and different distraction tasks gives only the possibility to discuss general effects of alcohol and distraction tasks.

In Fig. 9 the eleven parameters of the model are given. The conditions A, B and C are respectively the sessions with distraction task, sessions with alcohol and sessions without capacity reduction. The means and standard deviations are given for the above mentioned averages of three test runs (solid lines). The figure shows also the estimated parameters (one single value for each parameter) of the average of all comparable test runs (dashed lines).

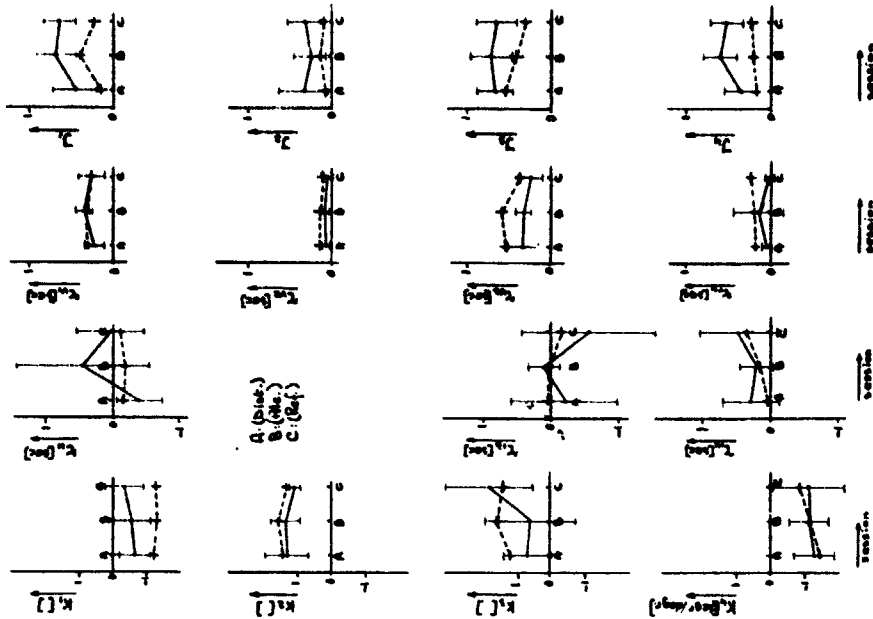

Fig. 9 The parameters of the model of the bicycle rider obtained from averages (of 3 test runs) for each subject separately (solid line) and from the average (of 18 test runs) of all comparable measurements (dashed line).

Furthermore the values of the cost criterion are given, which gives an indication about the quality of the fit to the data points. Even after averaging it turned out that the cost criterion  $J_3$  remained large thus for  $H_3(v)$  no reasonable fit could be made. The Bode plots and estimated transfer functions of the overall averages are given in fig. 10. Finally table 1 shows those differences which turned out to be significant based on a paired t-test. These results will be discussed in section 6.

Table 1 Significant changes in estimated parameters. The levels of significance p are given in the table

	A-B	A-C	B-C
$H_1$	-	-	-
$K_1$	-	-	-
$T_{11}$	-	-	-
$V_1$	$p = .05A$	-	-
$V_2$	$p = .05A$	-	-
$H_2$	A-B	A-C	B-C
$K_2$	-	$p = .05A$	-
$T_{21}$	-	$p = .10$	$p = .10$
$V_3$	-	A-C	B-C
$K_3$	-	-	-
$T_{31}$	-	$p = .05A$	-
$V_4$	-	$p = .05A$	-
$V_5$	$p = .05A$	$p = .05A$	$p = .05C$

5.2 THE PHYSIOLOGICAL DATA

The results of the physiological measurements are summarized in Fig. 11. A very clear difference can be noticed between the values of the ECG

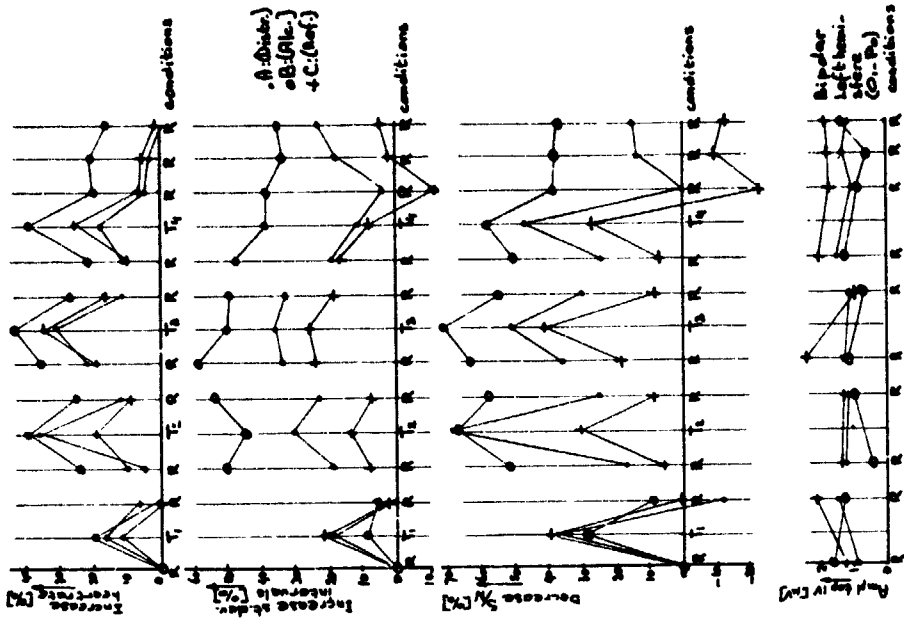

Fig. 11 Increase of heart rate, decrease of heart rate variability and the amplitude changes of top IV in the evoked response during the experimental conditions.

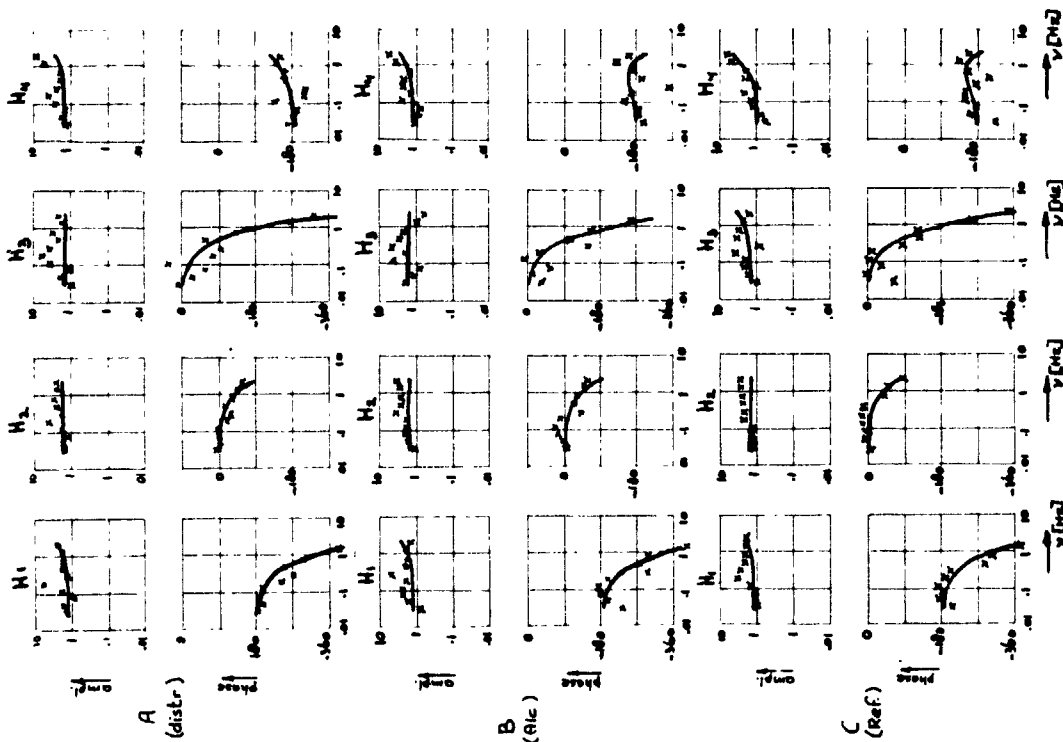

Fig. 10 The Bode plots and estimated transfer functions of the overall average.

measures between rest and task conditions. It also seems that the distraction task gives a suppression of the irregularity of heart rate, and the alcohol does even more. Furthermore a diurnal rhythm is seen in the ECG measures.

The change of top IV in the evoked response does not show clear effects. The recovery of the amplitude of top IV after the last test run seems to be retarded in the alcohol session.

## 6 DISCUSSION AND CONCLUSIONS

Two general remarks have to be made about the experimental scheme.

- Each experimental day the same scheme of taking blood samples by venous puncture has been performed. The anticipation of the subjects has probably given a large variance in task performance and also in the physiological measures. This is probably true for intraindividual as well as for intraindividual effects.

- There is a lot of experience on parameter estimation in describing function models for one dimensional systems. The situation described in this paper is not known in literature i.e.: a two dimensional system with cross-coupling of the signals in the system to be controlled and the human operator model. Therefore it was impossible to make an optimal experimental design with respect to repeated measures or the number of subjects required.

### 6.1 THE TASK PERFORMANCE

The subject had the possibility to stabilize the simulator with handle bar corrections or with upper body movements. The course could be followed only with handle bar corrections. It is already mentioned in the introduction that due to interference in the human motor system a coupling between upper body angle and course angle could exist. However it is concluded that this particular transfer function  $H_3(v)$  could not be estimated with reasonable reliability.

Based on the results of the transfer functions  $H_1(v)$ ,  $H_2(v)$  and  $H_4(v)$  the following conclusions can be drawn (see table I):

- The test runs with distraction task (A) show a smaller time delay in  $H_1$  than those with alcohol (B). The better result of the cost criterion can mean a better course following.
- At the same time the time delay of  $H_2$  and  $H_4$  are larger compared with test runs without capacity reduction (C), thus giving a decrement in the stabilization task.
- The decrease of the cost criterion for  $H_4$  in the runs with distraction indicates that the upper body movements become more important in stabilization.

A tentative conclusion can be that with the distraction task the course following receives more attention than with alcohol while the stabilization is done with upper body motions based on routine. This conclusion is in agreement with the decrease of the time delay in the stabilization with handle bar between distraction and the runs without reduction of capacity. Due to a smaller mental capacity in distraction runs it turns out that less mental capacity is given to the stabilization task which can be performed on the level of the spinal cord.

- The time delay constant in  $H_2$  enlarges in the test runs with alcohol (B), with increasing cost criterion for  $H_4$ . This seems in contradiction with some literature which states that small blood alcohol concentrations give better performance due to the anticipation of the subjects. An increase of the cost criterion for  $H_4$  in the runs with alcohol indicate that the stabilization is also deteriorated.

It suggests that the alcohol has a general effect, because of a decrease in stabilization for both aspects i.e.: the control by handle bar and upper body movements. This agrees with the results obtained in earlier studies on the bicycle simulator without the course following task (Ref. 12), there it is suggested that the stabilization is mainly done by the vestibular-cerebellar system. The handle bar motions, particular needed in the course following, are controlled by higher central nervous system centers, which is suggested to be more flexible and may compensate to a certain degree.

- Large differences between the parameters of individual subjects point to the possibility that each subject has his own strategy. Only repeated measurements can give more insight in these individual differences.

- It is seen in Fig. 9 that the value of the cost criterion after averaging the raw signals is much better than the mean value of the cost criterion for the individual estimation.

### 6.2 THE PHYSIOLOGICAL MEASURES

The main conclusion concerning the physiological measures is that the subjects showed a clear effect in the measures during the test run.

The recovery of the measures after the last test run cannot be interpreted as an effect of taskload, because of the effect of the anticipation on the venous punctures.

It seems better to do experiments without blood sampling during the experimental sessions. Individual blood alcohol curves obtained separately from the experiment can provide enough reliable estimates of blood alcohol concentrations during the experiments.

It is known from literature that alcohol has a general effect on most neurological systems. This agrees with the retarding recovery of the evoked response after the last test run, and also with the tentative conclusions about the performance data.

Finally it has to be stated that the differences in physiological measures of test runs with alcohol and test runs with the distraction task cannot be interpreted, because alcohol has also a pharmacological influence on the myocardial system.

## 7 ACKNOWLEDGEMENT

The research described in this paper is done in close cooperation with the Man-Machine Systems Group of the Delft University of Technology. The bicycle simulator is owned by this group. The support of this group, concerning software as well as hardware aspects was indispensable in this research.

The EEG investigations were carried out by Dr. J. L. Blom, who had also the responsibility for the medical aspects.



## 8 REFERENCES

1. ROLFE, J.M.; The measurement of human response in man-vehicle control situation. In: Monitoring behavior and supervisory control. Ed. T.B. Sheridan and G. Johansen, Nato conference series, series III: Human Factors, Plenum Press, New York, p.125-137.
2. WELFORD, A.T.; Evidence of a single-channel decision mechanism, limiting performance in several reaction tasks. *Quart Journal Exp. Psych.*, 11, 193-210.
3. KALSBECK, J.W.H., J.H. ETIEMA; Physiological and Psychological evaluation of distraction stress. *Ergonomics*, 7 (1974) 443-447.
4. KAHNEMAN, D.; Attention and Effort. Englewood Cliffs, N.J., Prentice Hall, (1973) 245 p.
5. BLOM, J.L.; L'influence de la charge mentale sur les potentiels évoqués. *Le Travail Humain*. 37 (1974) 139-212.
6. ROHMERT, W. et al.; Heart Rate Variability and Work-Load Measurement. *Ergonomics*, 16 (1973) 33-44.
7. LUNTEREN, A. van, H.G. STASSEN; Chapter III in Annual Report 1969 of the Man-Machine Systems Group. Delft University of Technology, WTHD 21, (1970) 15-33.
8. KALSBECK, J.W.H.; On the measurement of deterioration in performance caused by distraction stress. *Ergonomics*, 7 (1964) 339-367.
9. LUNTEREN, A. van, H.G. STASSEN; Parameter estimation in linear models of the human operator in a closed loop with application of deterministic test signals. *Proc. of the 9th Annual Conf. on Manual Control*, MIT, (1973) 289-297.
10. LUNTEREN, A. van; Parameter estimation in a human operator describing function model for a two-dimensional tracking task. To be presented at the 13th Annual Conf. on Manual Control, MIT (1977) 17 p.
11. OPMEER, C.H.J.M.; The information content of successive RR-interval times in the ECG. Preliminary results using factor analysis and frequency analysis. *Ergonomics*, 16 (1973) 105-112.
12. LUNTEREN, A. van, H.G. STASSEN; Chapter IV in Annual Report 1969 of the Man-Machine Systems Group, Delft University of Technology, WTHD 21, (1970) 34-55.