

Apollo-Soyuz  
Pamphlet No. 8:

ORIGINAL PAGE IS  
OF POOR QUALITY

# Zero-G Technology

(NASA-EP-140) APOLLO-SOYUZ PAMPHLET NO. 8:  
ZERO-G TECHNOLOGY (National Aeronautics and  
Space Administration) 68 p MF A01; SOD HC  
set of 9 volumes

N78-27153

CSSL 22A

G3/12

Unclas  
24995





**Apollo-  
Soyuz  
Experiments  
In  
Space**

**This is one of a series of nine  
curriculum-related pamphlets  
for Teachers and Students  
of Space Science**

**Titles in this series of  
pamphlets include:**

- EP-133 Apollo-Soyuz Pamphlet No. 1: The Flight
- EP-134 Apollo-Soyuz Pamphlet No. 2: X-Rays, Gamma-Rays
- EP-135 Apollo-Soyuz Pamphlet No. 3: Sun, Stars, In Between
- EP-136 Apollo-Soyuz Pamphlet No. 4: Gravitational Field
- EP-137 Apollo-Soyuz Pamphlet No. 5: The Earth from Orbit
- EP-138 Apollo-Soyuz Pamphlet No. 6: Cosmic Ray Dosage
- EP-139 Apollo-Soyuz Pamphlet No. 7: Biology in Zero-G
- EP-140 Apollo-Soyuz Pamphlet No. 8: Zero-G Technology
- EP-141 Apollo-Soyuz Pamphlet No. 9: General Science

**On The Cover**

**Four-Second Growth Layers in a Germanium Crystal  
Grown in Zero-g, Magnified x 50**

Apollo-Soyuz  
Pamphlet No.8:

# Zero-G Technology

---

Prepared by Lou Williams Page and Thornton Page From  
Investigators' Reports of Experimental Results and With  
the Help of Advising Teachers

**ORIGINAL CONTAINS  
COLOR ILLUSTRATIONS**

**NASA**

National Aeronautics and  
Space Administration

Washington, D.C. 20546  
October 1977

For sale by the Superintendent of Documents,  
U.S. Government Printing Office, Washington, D.C. 20402  
(9-Part Set; Sold in Sets Only)  
Stock Number 033-800-00688-8



# Preface

The Apollo-Soyuz Test Project (ASTP), which flew in July 1975, aroused considerable public interest; first, because the space rivals of the late 1950's and 1960's were working together in a joint endeavor, and second, because their mutual efforts included developing a space rescue system. The ASTP also included significant scientific experiments, the results of which can be used in teaching biology, physics, and mathematics in schools and colleges.

This series of pamphlets discussing the Apollo-Soyuz mission and experiments is a set of curriculum supplements designed for teachers, supervisors, curriculum specialists, and textbook writers as well as for the general public. Neither textbooks nor courses of study, these pamphlets are intended to provide a rich source of ideas, examples of the scientific method, pertinent references to standard textbooks, and clear descriptions of space experiments. In a sense, they may be regarded as a pioneering form of teaching aid. Seldom has there been such a forthright effort to provide, directly to teachers, curriculum-relevant reports of current scientific research. High school teachers who reviewed the texts suggested that advanced students who are interested might be assigned to study one pamphlet and report on it to the rest of the class. After class discussion, students might be assigned (without access to the pamphlet) one or more of the "Questions for Discussion" for formal or informal answers, thus stressing the application of what was previously covered in the pamphlets.

The authors of these pamphlets are Dr. Lou Williams Page, a geologist, and Dr. Thornton Page, an astronomer. Both have taught science at several universities and have published 14 books on science for schools, colleges, and the general reader, including a recent one on space science.

Technical assistance to the Pages was provided by the Apollo-Soyuz Program Scientist, Dr. R. Thomas Giuli, and by Richard R. Baldwin, W. Wilson Lauderdale, and Susan N. Montgomery, members of the group at the NASA Lyndon B. Johnson Space Center in Houston which organized the scientists' participation in the ASTP and published their reports of experimental results.

Selected teachers from high schools and universities throughout the United States reviewed the pamphlets in draft form. They suggested changes in wording, the addition of a glossary of terms unfamiliar to students, and improvements in diagrams. A list of the teachers and of the scientific investigators who reviewed the texts for accuracy follows this Preface.

This set of Apollo-Soyuz pamphlets was initiated and coordinated by Dr. Frederick B. Tuttle, Director of Educational Programs, and was supported by the NASA Apollo-Soyuz Program Office, by Leland J. Casey, Aerospace Engineer for ASTP, and by William D. Nixon, Educational Programs Officer, all of NASA Headquarters in Washington, D.C.

Appreciation is expressed to the scientific investigators and teachers who reviewed the draft copies; to the NASA specialists who provided diagrams and photographs; and to J. K. Holcomb, Headquarters Director of ASTP operations, and Chester M. Lee, ASTP Program Director at Headquarters, whose interest in this educational endeavor made this publication possible.



## **Teachers And Scientific Investigators Who Reviewed the Text**

Harold L. Adair, Oak Ridge National Laboratory, Oak Ridge, Tenn.  
Lynette Aey, Norwich Free Academy, Norwich, Conn.  
J. Vernon Bailey, NASA Lyndon B. Johnson Space Center, Houston, Tex.  
Stuart Bowyer, University of California at Berkeley, Berkeley, Calif.  
Bill Wesley Brown, California State University at Chico, Chico, Calif.  
Ronald J. Bruno, Creighton Preparatory School, Omaha, Nebr.  
T. F. Budinger, University of California at Berkeley, Berkeley, Calif.  
Robert F. Collins, Western States Chiropractic College, Portland, Oreg.  
B. Sue Criswell, Baylor College of Medicine, Houston, Tex.  
T. M. Donahue, University of Michigan, Ann Arbor, Mich.  
David W. Eckert, Greater Latrobe Senior High School, Latrobe, Pa.  
Lyle N. Edge, Blanco High School, Blanco, Tex.  
Victor B. Eichler, Wichita State University, Wichita, Kans.  
Farouk El-Baz, Smithsonian Institution, Washington, D.C.  
D. Jerome Fisher, Emeritus, University of Chicago, Phoenix, Ariz.  
R. T. Giuli, NASA Lyndon B. Johnson Space Center, Houston, Tex.  
M. D. Grossi, Smithsonian Astrophysical Observatory, Cambridge, Mass.  
Wendy Hindin, North Shore Hebrew Academy, Great Neck, N.Y.  
Tim C. Ingoldsby, Westside High School, Omaha, Nebr.  
Robert H. Johns, Academy of the New Church, Bryn Athyn, Pa.  
D. J. Larson, Jr., Grumman Aerospace, Bethpage, N.Y.  
M. D. Lind, Rockwell International Science Center, Thousand Oaks, Calif.  
R. N. Little, University of Texas, Austin, Tex.  
Sarah Manly, Wade Hampton High School, Greenville, S.C.  
Katherine Mays, Bay City Independent School District, Bay City, Tex.  
Jane M. Oppenheimer, Bryn Mawr College, Bryn Mawr, Pa.  
T. J. Pepin, University of Wyoming, Laramie, Wyo.  
H. W. Scheld, NASA Lyndon B. Johnson Space Center, Houston, Tex.  
Seth Shulman, Naval Research Laboratory, Washington, D.C.  
James W. Skehan, Boston College, Weston, Mass.  
B. T. Slater, Jr., Texas Education Agency, Austin, Tex.  
Robert S. Snyder, NASA George C. Marshall Space Flight Center, Huntsville, Ala.  
Jacqueline D. Spears, Port Jefferson High School, Port Jefferson Station, N.Y.  
Robert L. Stewart, Monticello High School, Monticello, N.Y.  
Aletha Stone, Fulmore Junior High School, Austin, Tex.  
G. R. Taylor, NASA Lyndon B. Johnson Space Center, Houston, Tex.  
Jacob I. Trombka, NASA Robert H. Goddard Space Flight Center, Greenbelt, Md.  
F. O. Vonbun, NASA Robert H. Goddard Space Flight Center, Greenbelt, Md.  
Douglas Winkler, Wade Hampton High School, Greenville, S.C.

**Page  
Intentionally  
Left Blank**



# Contents

---

<b>Section 1</b>	Introduction: The Value of Several Space Technologies .....	1
	A. "Housekeeping" Technology .....	2
	B. Biological and Medical Technology .....	2
	C. Chemical Technology .....	3
	D. Metallurgical Technology .....	3
	E. Power Technology in Space .....	4

---

<b>Section 2</b>	The Behavior of Liquids in Zero-g .....	7
	A. The Chemical-Foam Demonstration .....	7
	B. The Liquid-Spreading Demonstration .....	9
	C. The Wick Demonstration .....	10
	D. Questions for Discussion (Foam, Wetting, Wicks) .....	11

---

<b>Section 3</b>	High-Temperature Processing of Metals and Salts in Zero-g .....	13
	A. The MA-010 Multipurpose Furnace .....	13
	B. Lead-Zinc and Aluminum-Antimony Alloys Produced in the MA-044 Experiment .....	16
	C. Melting of Aluminum, Tungsten, Germanium, and Silicon in Zero-g .....	21
	D. Diffusion of Gold Into Molten Lead .....	22
	E. Magnetic Alloys Formed in Zero-g .....	23
	F. Transparent Fibers From a Eutectic .....	26
	G. Questions for Discussion (Heat Transport, Temperature, Alloys, Eutectics) .....	30

---

<b>Section 4</b>	Growing Large, Nearly Perfect Crystals in Zero-g .....	33
	A. Growth of Large Germanium Crystals .....	33
	B. Growth of Crystals From Vapor .....	37
	C. Growth of Crystals From Solution .....	40
	D. Questions for Discussion (Cleavage Planes, Crystal Growth) .....	45

---

<b>Appendix A</b>	Discussion Topics (Answers to Questions) .....	46
-------------------	--	----

---

<b>Appendix B</b>	SI Units and Powers of 10 .....	50
-------------------	---------------------------------	----

---

<b>Appendix C</b>	Glossary .....	53
-------------------	----------------	----

---

<b>Appendix D</b>	Further Reading .....	59
-------------------	-----------------------	----

---

# Figures

---

<b>Figure 2.1</b>	Chemical Reaction Speed in Foam .....	8
<b>2.2</b>	Liquid Spreading in Zero-g .....	9
<b>2.3</b>	Wick Action in Zero-g .....	10

---

<b>Figure 3.1</b>	MA-010 Multipurpose Electric Furnace .....	13
<b>3.2</b>	Diagram of Furnace Control System .....	15
<b>3.3</b>	Diagram of MA-044 Cartridge for Alloys .....	17
<b>3.4</b>	Temperature Versus Time in MA-044 Cartridges .....	18
<b>3.5</b>	Photographs of Lead-Zinc Ingots in Zero-g and One-g .....	19
<b>3.6</b>	Microstructure of Al-Sb Alloy Formed in Zero-g and One-g .....	20
<b>3.7</b>	Temperature Versus Time in the Soviet Materials Melting Experiment .....	21
<b>3.8</b>	Diagram of MA-070 Cartridge for Magnetic Alloys .....	24
<b>3.9</b>	Fibers in Magnetic Eutectic From Experiment MA-070 .....	25
<b>3.10</b>	Diagram of MA-131 Cartridge for NaCl-LiF Eutectic .....	26
<b>3.11</b>	LiF Fibers at the Unmelted Salt Boundary in Experiment MA-131 .....	27
<b>3.12</b>	Parallel LiF Fibers Formed in Zero-g and One-g .....	28
<b>3.13</b>	Cross Sections of Fibers in NaCl-LiF Eutectic .....	29

---

<b>Figure 4.1</b>	Diagram of MA-060 Cartridge for Germanium Crystal Growth .....	35
<b>4.2</b>	Interface Demarcation Lines in Germanium Crystal Grown in Zero-g .....	36
<b>4.3</b>	Rate of Germanium Crystal Growth in Zero-g .....	37
<b>4.4</b>	GeSe Crystals Formed From Vapor in a Quartz Tube .....	39
<b>4.5</b>	GeSe Crystals Formed in One-g and in Zero-g .....	40
<b>4.6</b>	Diagram of the MA-028 Reactor for Forming Crystals in Solutions .....	41
<b>4.7</b>	The Six MA-028 Reactors for Apollo-Soyuz .....	42
<b>4.8</b>	Crystals of Calcium Tartrate and Calcite Grown in Experiment MA-028 .....	44

---



# 1 Introduction

## The Value of Several Space Technologies

After 4 years of preparation by the U.S. National Aeronautics and Space Administration (NASA) and the U.S.S.R. Academy of Sciences, the Apollo and Soyuz spacecraft were launched on July 15, 1975. Two days later at 16:09 Greenwich mean time on July 17, after Apollo maneuvered into the same orbit as Soyuz, the two spacecraft were docked. The astronauts and cosmonauts then met for the first international handshake in space, and each crew entertained the other crew (one at a time) at a meal of typical American or Russian food. These activities and the physics of reaction motors, orbits around the Earth, and weightlessness (zero-g) are described more fully in Pamphlet I, "The Spacecraft, Their Orbits, and Docking" (EP-133).

Thirty-four experiments were performed while Apollo and Soyuz were in orbit: 23 by astronauts, 6 by cosmonauts, and 5 jointly. These experiments in space were selected from 161 proposals from scientists in nine different countries. They are listed by number in Pamphlet I and groups of two or more are described in detail in Pamphlets II through IX (EP-134 through EP-141, respectively). Each experiment was directed by a Principal Investigator, assisted by several Co-Investigators, and the detailed scientific results have been published by NASA in two reports: the Apollo-Soyuz Test Project Preliminary Science Report (NASA TM X-58173) and the Apollo-Soyuz Test Project Summary Science Report (NASA SP-412). The simplified accounts given in these pamphlets have been reviewed by the Principal Investigators or one of the Co-Investigators.

To most people, space technology means the rockets, thrusters, and control jets and the general structure of spacecraft described in Pamphlet I. Actually, space technology also includes the Earth observations (gravity anomalies, surface features, and atmospheric features) described in Pamphlets IV and V, the observations of near-Earth radiation detailed in Pamphlet VI, and some of the biological and medical techniques covered in Pamphlet VII. Future space technology will include various surveys of the Earth; photography and mapping of the surface; monitoring of the atmosphere and its aerosols; monitoring of cosmic rays, which are affected by the Earth's magnetic field; and electrophoresis separations in zero-g. Several new techniques are expected to be developed for chemistry, metallurgy, and solar power in space. There are at least five different space technologies: "housekeeping," biological and medical, chemical, metallurgical, and power. Three of these technologies are covered in Sections 2, 3, and 4 of this pamphlet.

## A “Housekeeping” Technology

During and after the launch of Apollo, or Soyuz, or any other spacecraft, reaction motors are used to push and turn the vehicle (see Pamphlet I). This is a basic technology largely developed by the Germans for long-range military missiles in World War II. When the spacecraft is in orbit and no reaction motors are being fired, it is in the condition of free fall or zero-g,<sup>1</sup> and everything inside the spacecraft is weightless. This weightless condition requires special design technology, such as tether lines, handholds, and Velcro anchors to keep tools and astronauts at the places where they are needed. One particular problem is the handling of liquids (such as water) in tanks. In zero-g, water does not stay at the “bottom” of a partly filled tank. For the Apollo-Soyuz mission, several “science demonstrations” on the handling of liquids in zero-g were planned by R. S. Snyder and five Co-Investigators from the NASA George C. Marshall Space Flight Center (MSFC) in Huntsville, Alabama. These demonstrations are described in Section 2.

## B Biological and Medical Technology

Scientists speculate that some biological processes may take place faster in zero-g than in one-g on Earth (although one fungus carried on Apollo-Soyuz grew slower; see Pamphlet VII). If so, there may be a new technology to produce vaccines and other medicines more efficiently in space. On Apollo-Soyuz, the process of separating cells by electrophoresis was shown to be more precise in zero-g than in one-g on the ground (Pamphlet VII). This discovery could lead to at least one important space technique that would accelerate the production of urokinase for the victims of heart disease and other conditions.

Another speculation is that the higher intensity of cosmic rays and high-energy protons at altitudes from 300 to 3000 kilometers (Pamphlets II and VI) might be used to prepare mutations of living cells found on Earth. This could lead to a new technology of “breeding” cells that we need and of discovering new breeds of bacteria that we must defend against when they appear on Earth. (A similar technology has already been developed in ground-based laboratories.)

---

<sup>1</sup>“Project Physics,” second edition, Holt, Rinehart and Winston, 1975, Secs. 4.6, 4.7; “Physical Science Study Committee” (PSSC), fourth edition, D. C. Heath, 1976, Secs. 12-6, 12-12.



## C Chemical Technology

In zero-g, many chemical reactions are known to take place faster because gravity does not separate the reactants. Scientists speculate that some perfectly pure substances could be prepared in space by heating impure samples in a "solar furnace" outside the spacecraft and boiling off the contaminants. The basis of this idea is that the sample need not be in contact with the furnace walls; instead, it would be "floating" in the vacuum of space where a concave mirror could focus sunlight on it.

On Apollo-Soyuz, three experiments were concerned with the growth of pure crystals. They are described more fully in Section 4 of this pamphlet.

*Experiment MA-060, Interface Markings in Crystals*, was supervised by H. C. Gatos of the Massachusetts Institute of Technology (MIT) who was assisted by one Co-Investigator. The experiment measured germanium crystal growth rates.

*Experiment MA-085, Crystal Growth From the Vapor Phase*, showed in three separate experiments that the vapors of germanium compounds formed more perfect crystals in zero-g than on Earth in one-g. The Principal Investigator was H. Wiedemeier of Rensselaer Polytechnic Institute (RPI); he was assisted by three Co-Investigators.

*Experiment MA-028, Crystal Growth*, was supervised by M. D. Lind of the Rockwell International Science Center in California. He showed that crystals of three different compounds can be grown from solution in zero-g at room temperature (290 to 300 K, or 15° to 25° C, or 60° to 80° F).

## D Metallurgical Technology

Three techniques of importance in modern industry are the containerless casting of reactive metals, the formation of uniform alloys, and the formation of strong eutectics. The first technique can be done easily in zero-g because there is no gravity to deform a liquid melt. A drop of molten metal, for example, will be pulled into a perfect sphere by surface tension if it is not in contact with furnace walls. Because the metal need not touch the furnace walls, it is not contaminated or constrained by them. In the formation of uniform alloys, a mix of two molten materials will not tend to separate in zero-g as it cools to form an alloy. A eutectic is a combination of two materials that has a lower melting point than either material alone. ("Eutectic" is a Greek word meaning "minimum melting point.") The two materials do not mix like an alloy; instead, one material forms a regular pattern when it solidifies inside the other. The most useful eutectics consist of long thin fibers of one material through the other. It is possible to grow the fibers longer and more nearly parallel in zero-g than in one-g.

The metallurgical experiments on Apollo-Soyuz were based on a specially designed electric furnace located in the Docking Module (DM). It could heat samples to as high as 1423 K (1150° C), as described in Section 3. Six experiments on spheres, alloys, and eutectics, as well as two of the three experiments on crystal growth, were done in this furnace.

*Experiment MA-010, the Multipurpose Electric Furnace* facility, developed at MSFC under the supervision of A. Boese, was highly successful.

*Experiment MA-044, Monotectic and Syntectic Alloys*, showed that the uniformity of aluminum-antimony (Al-Sb) alloys produced in zero-g was much better than the uniformity of those produced in one-g on Earth. The two Principal Investigators were C. Y. Ang and L. L. Lacy of MSFC.

*Experiment MA-150, Multiple Material Melting*, was a joint experiment designed by I. Ivanov of the Soviet Institute for Metallurgy in Moscow. He was assisted by several Russian and two American Co-Investigators. The zero-g formation of aluminum spheres and two alloys (aluminum-tungsten and germanium-silicon) was compared with formation in one-g on Earth.

*Experiment MA-041, Surface-Tension-Induced Convection*, measured the small amount of material flow produced by surface tension in molten lead and gold. The Principal Investigator was R. E. Reed of Oak Ridge National Laboratory in Tennessee.

*Experiment MA-070, Zero-g Processing of Magnets*, was supervised by D. J. Larson, Jr., of Grumman Aerospace Corporation in New York. The experiment showed that better magnetic eutectics of manganese-bismuth can be produced in zero-g than in one-g.

*Experiment MA-131, Halide Eutectic Growth*, showed that long, thin fibers of lithium fluoride (LiF) form in sodium chloride (NaCl) when the two salts are melted together and cooled rapidly, starting at one end. The Principal Investigator was A. S. Yue of the University of California at Los Angeles (UCLA); he was assisted by two Co-Investigators.

## **E Power Technology in Space**

Although the Apollo-Soyuz experiments did not relate to solar power, it should be noted that power technology is expected to develop rapidly in the 1980's. The worldwide power shortage has increased the importance of solar power. Professor Gerard O'Neill of Princeton University has suggested that space colonies should be built where orbiting solar-power stations could be manufactured more cheaply and more quickly than on Earth. Some of the many articles on space colonies and orbiting solar-power stations are reviewed in a book entitled "Space Science and Astronomy" (Macmillan Co., 1976). The proposed solar-power stations would be huge collectors (40 to 50

kilometers across) in geosynchronous orbit 36 000 kilometers above the Equator. In this kind of orbit, the stations would always be over the same point on Earth and could beam 10 or 20 thousand megawatts of power by microwaves (very short radio waves) to a ground receiving station in the southwestern United States or elsewhere at low latitude.

The sunlight might be converted to electricity with silicon cells that NASA developed in the 1960's for the solar-power panels on spacecraft. Another possibility is to use the sunlight to heat a gas that would drive turboelectric generators as in a regular electric powerplant on Earth. Either way, a new technology must be developed to handle such high electrical power output on an orbiter and to convert it to microwaves aimed at the ground receiver.

**Page Intentionally Left Blank**



## 2 The Behavior of Liquids in Zero-g

The behavior of liquids anywhere depends on their boundary surfaces—that is, where they come in contact with solids or gases. At the boundary of a liquid and a solid, two kinds of force are in competition: *cohesive force* pulling the liquid molecules together and *adhesive force* pulling the liquid molecules toward the solid. If the adhesive force is larger, the liquid will wet the solid smoothly. If the cohesive force is larger, small amounts of liquid will form little droplets on the solid surface, like water on greasy hands. On Earth, of course, there is a third force—gravity—that pulls the liquid downward. Gravity pulls the water down into the bottom of a cup and keeps it from wetting far up the sides. Oil, however, has a large adhesive force with metal and will stay spread all over a metal surface in one-g.

Detergents, like soap, change the surface of liquids such as water, so that bubbles on the surface of soapy water last for several minutes in one-g. Gravity finally pulls the water down the sides of the bubbles, and the bubbles get so thin that they break (because of the motions of the water molecules). Liquids in bubbles or *foam* are important in several ways: they are used in fighting fires, in making lightweight plastics and foam rubber, and in speeding up some chemical reactions between gases and liquids.

*Wicks* move liquids against gravity when there is a strong adhesive force between the liquid and the solid fibers in the wick. For instance, the wick of a candle pulls molten wax up about 5 millimeters, where it burns easily in the candle flame. A towel acts as a wick when it lifts water off a surface to dry it. In zero-g, wicks can be used instead of pumps to transport liquids from tanks to wherever they are needed in a spacecraft.

Space engineers have learned to handle several liquids in zero-g—water, propellant fuel, liquid oxygen, oil, and waste. They have difficulty in measuring adhesive and cohesive forces on Earth because the one-g gravity force interferes. When they try to measure the chemical reaction time in a foam in one-g, for example, the foam collapses after a few minutes. Therefore, demonstrations of chemical foaming, liquid spreading on a solid surface, and liquid motion in a wick were photographed and timed by the astronauts on Apollo-Soyuz.

### A The Chemical-Foam Demonstration

Three chemicals were added to water in a small plastic bottle, which was then corked and shaken vigorously to make a foam. Thymol blue, a detector that turns pink in an acid solution (like litmus paper), had been added to the water. The chemicals were sodium sulfite ( $\text{NaSO}_3$ ), sodium hydrogen sulfite ( $\text{NaHSO}_3$ ), and formaldehyde ( $\text{HCHO}$ ). Three reactions took place, yielding  $\text{SO}_3^{--}$  ions which turned the foam pink in less than 20 seconds and the rest of

the solution pink in about 1 minute (Fig. 2.1). This demonstration shows that in zero-g a complex chemical reaction can be speeded up in foam. The same reaction would also be speeded up in one-g if the foam would last, but it collapses in less than 20 seconds.

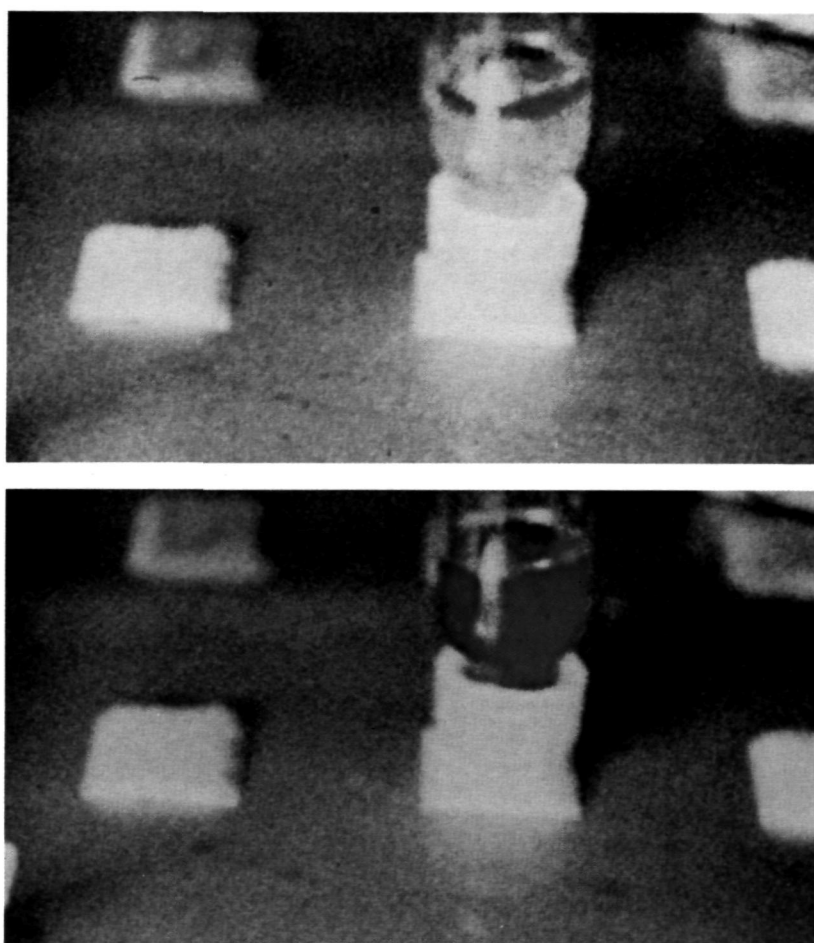

**Figure 2.1** Chemical reaction speed in foam. Just after mixing and shaking the three chemicals in water, the foam began turning pink (top photograph). After 60 seconds, the reaction was complete and the foam was dark red (bottom photograph).

## B The Liquid-Spreading Demonstration

In zero-g, a small amount of liquid wets more than the bottom of a cup; it wets the entire cup. This was demonstrated on Apollo-Soyuz by squirting a small amount of blue-colored oil into the bottom of a cubical plastic cup. The oil quickly spread over the bottom and then up the sides. The adhesive force between oil and plastic is stronger than the cohesive force of the oil. Blue oil collected in the corners of the cubical cup because the sharp corner allowed the cohesive force to work more nearly with the adhesive force there (Fig. 2.2). When red-colored water was later added on top of the oil, it formed round drops because the adhesive force between water and oil is much smaller than the cohesive force of water. The speed of oil spreading in zero-g was measured from motion pictures taken by the astronauts, and this zero-g surface tension helps us to understand the liquid spreading of solder, molten metals, and insecticides in one-g on Earth.

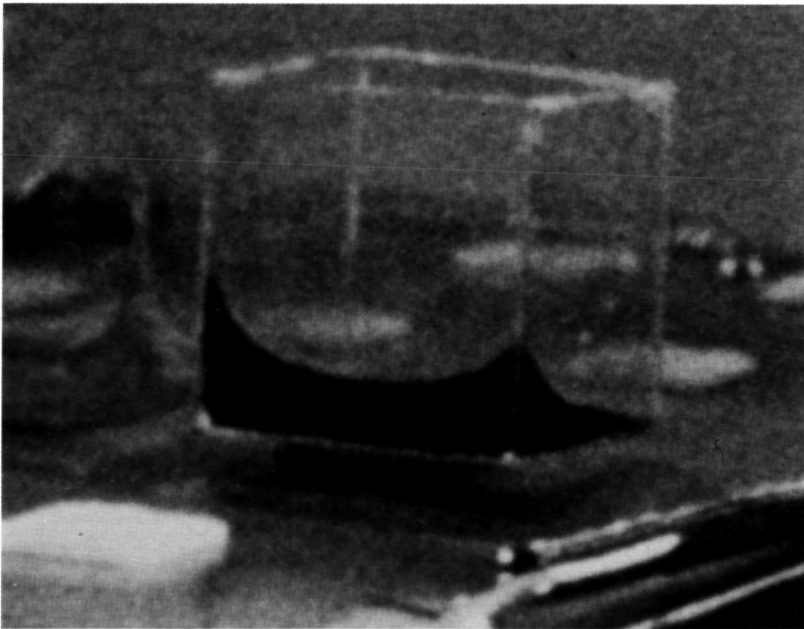

**Liquid spreading in zero-g. Blue-colored oil rapidly spreads up the sides of the cubical plastic cup. (This photograph was taken during a zero-g airplane flight, not on Apollo-Soyuz.)**

**Figure 2.2**

ORIGINAL PAGE IS  
OF POOR QUALITY

## C The Wick Demonstration

Wicks are very efficient in zero-g because the fluid being “pulled up” has no weight. Four wicks, each 10 centimeters long and 1 centimeter wide, were held in a frame so that each wick dipped into a plastic cup at one end. Three of the wicks were made of stainless-steel wire interwoven in different ways. The fourth wick was made of nylon. Blue-colored soapy water and blue-colored silicone oil were squirted into the cups, and the motion of each fluid up the wicks was timed. Both the oil and the water moved up the wicks much faster than expected, and the oil moved faster than the water (Fig. 2.3). Timing showed that the stainless-steel wick with the Plain Dutch weave was most efficient in zero-g.

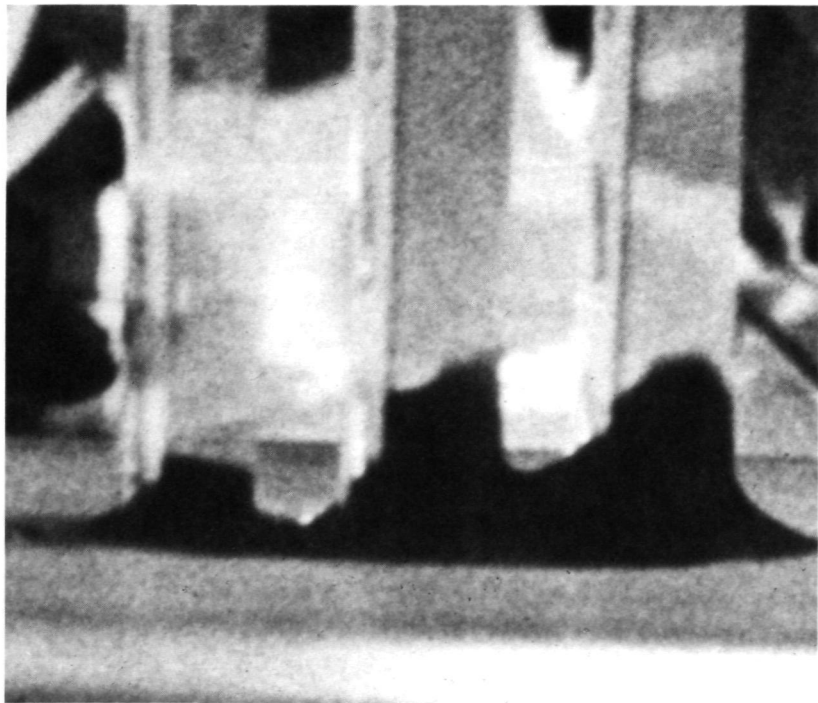

**Figure 2.3** Wick action in zero-g. Three of the wicks can be seen between columns of the supporting frame. When colored water and oil were squirted into the cups at the lower ends of the wicks, the motion of the liquids up the wicks was watched and timed. (This photograph was taken during a zero-g airplane flight, not on Apollo-Soyuz.)

## **D Questions for Discussion**

(Foam, Wetting, Wicks)

1. It has been suggested that styrofoam and other hardened plastic foams could be strengthened by adding strong metal fibers to the foam before it solidified. Compare how such a process would work in zero-g and one-g.
2. What happens to the oil when it gets to the top of the open-cube cup in zero-g?
3. What forces account for oil moving faster than water along a wick in zero-g?



**Page Intentionally Left Blank**

### 3 High-Temperature Processing of Metals and Salts in Zero-g

An electric furnace designed and built by Westinghouse had been used to melt metals on the long Skylab missions in 1973-74. The MA-010 furnace used on Apollo-Soyuz was basically the same as the Skylab furnace, with improvements to shorten the heating and cooling times. The major requirement was flexibility so that the furnace could be used for seven different experiments, five of which are described in this section.

#### A The MA-010 Multipurpose Furnace

The materials to be heated in the furnace were enclosed in standard-size cartridges, each 2.1 centimeters in diameter and 20.5 centimeters long. Three such cartridges could be fitted inside the vacuum-tight furnace case shown on the right side of Figure 3.1. Electric current through resistors was used to heat

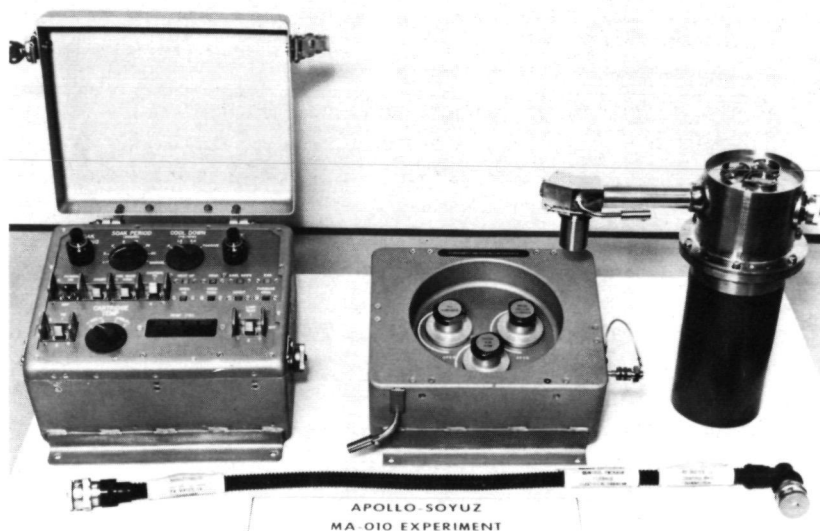

ORIGINAL PAGE IS  
OF POOR QUALITY

The MA-010 multipurpose electric furnace. The furnace is the cylinder on the right, about 22 centimeters high and 9 centimeters in diameter. There are three openings in the top for inserting the three cartridges to be heated. The center box contained helium and the controls for releasing small amounts into the furnace for cooling. The control box on the left has dials and switches to set automatic heatup and cooldown rates and soak times.

Figure 3.1

the materials in each cartridge. The current was controlled by the box shown on the left side of Figure 3.1. The temperature could be made to rise as rapidly as 400 K/hr (400° C/hr) or it could be held constant. Cooling was accomplished by turning off the electric current and injecting helium gas into the furnace. This allowed heat to escape from the hot cartridges, which had been well insulated in vacuum during the period of high temperature. The temperature dropped from its maximum of 1423 K (1150° C) to 423 K (150° C) in about 3 hours. (Without the helium conduction of heat, the cooldown would have taken 20 hours.) The middle box in Figure 3.1 contained the helium and three valves for controlling the small amount (0.16 cubic centimeter) released into the furnace case. The entire experiment was fastened to the inside wall of the Docking Module (DM; see Pamphlet I).

To get rapid heating with minimum heat loss, Westinghouse used nickel wires around graphite in contact with the "hot end" of the cartridges to be heated. The nickel heating wires were covered with alumina ( $\text{Al}_2\text{O}_3$ ) cement. Every possible heat loss from each insulated cartridge was reduced so that only 10 watts of the 205-watt heater power were lost through heat conduction. This heat-loss reduction was possible because the heated cartridges were isolated in a vacuum in the furnace case. Before the heater was started, the sealed furnace case was evacuated through a tube to the vacuum of space outside the DM.

A schematic diagram of the MA-010 furnace control box is shown in Figure 3.2. The diagram shows that the astronaut or cosmonaut could select the temperature requested by the Principal Investigator for each furnace experiment. The temperature was then automatically controlled by two thermocouples (electric thermometers), one at the "hot end" of the experiment cartridge (bottom of the case in Fig. 3.1) and one at the cool end. (Both temperatures were recorded as a function of time.) The "soak period" of 1 to 6 hours was the time during which the furnace remained at maximum temperature to homogenize the material. The cooldown rate, which controlled the timing and the amount of helium cooling, was also set. From the temperature-versus-time curves for the two ends of each experiment cartridge, the Principal Investigator knew exactly how his alloy, eutectic, or crystal had been heated, soaked, and cooled.

Diagram of the MA-010 furnace control system. The "Temperature select" at the left is a dial on the control box shown in Figure 3.1 that is set by the astronaut. "Soak period selection" on the right is a similar dial. The indicator lights ("Indication function," lower left) showed whether the furnace was heating up, soaking, or cooling. The heater (far right) was automatically turned off for cooling or if a breakdown occurred.

Figure 3.2

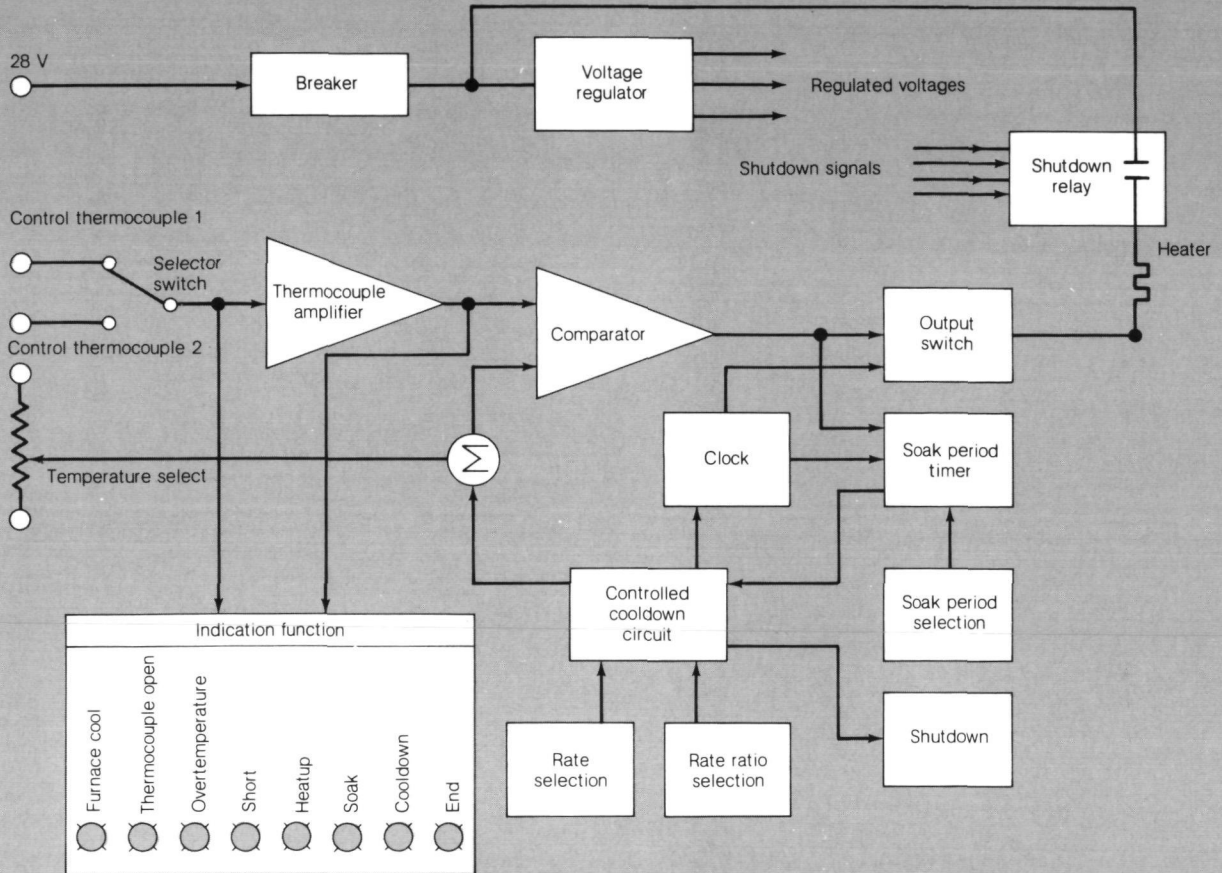

## B Lead-Zinc and Aluminum-Antimony Alloys Produced in the MA-044 Experiment

The MA-044 cartridge for the electric furnace is shown in Figure 3.3. Each of three cartridges contained two small "ampoules" inside a stainless-steel cylinder with a "Fiberfrax" insulation lining in the middle and heat-leveling graphite at the ends. By using this design, the Principal Investigators got one sample, in Ampoule A, heated to 1423 K (1150° C) and the other, in Ampoule B, heated to 1123 K (850° C). After a 3-hour 20-minute heatup period, both samples were soaked for 1 hour, then cooled down for 6.5 hours. The copper surrounding Ampoule B kept all of that ampoule at the same temperature, even though there was a difference in temperature between the hot end and the cool end of the furnace.

The mixture of lead (Pb) and zinc (Zn) was chosen because these two metals have very different density (11.35 gm/cm<sup>3</sup> for Pb and 7.14 gm/cm<sup>3</sup> for Zn) and cannot be mixed well in one-g. The small ingot in Ampoule B was made in the laboratory by putting 0.33 cubic centimeter (3.9 grams) of pure Pb on top of 0.66 cubic centimeter (4.7 grams) of pure Zn and heating it in a furnace to 1123 K (above the melting points of Pb and Zn) for 10 minutes. Gravity (one-g) pulled the denser Pb down into the Zn but did not mix them well. It was expected that the hour-long soak at 1123 K in zero-g would mix them much better.

Before the Apollo-Soyuz flight, three similar cartridges had been prepared and heated in a furnace identical to the one on Apollo-Soyuz. These laboratory tests showed exactly what the temperatures in Ampoules A and B were for each set of recorded temperatures at the ends of the MA-044 cartridge. Temperature-time plots are shown in Figure 3.4.

As shown in Figure 3.5, the molten Pb did not mix with the molten Zn in zero-g. Both in zero-g and in one-g, the interface between Pb and Zn remained sharp. Careful chemical tests and electrical measurements showed very little diffusion of the lead into the zinc. The diffusion had been expected to be much larger. These results show errors in one-g laboratory work on diffusion in molten metals. The Principal Investigators consider that there is a need for further experiments in zero-g, where diffusion can be measured accurately.

The aluminum (Al) and antimony (Sb) mix forms an actual compound, aluminum antimonide (AlSb), which has technological importance because it is a very good material for solar cells that convert sunlight into electric power. In fact, the compound AlSb should be 30 to 50 percent more efficient than the silicon that has been used in solar cells on many NASA spacecraft and on Soyuz (but not on Apollo; see Pamphlet I). The difficulty is in mixing Al (density 2.7 gm/cm<sup>3</sup>) perfectly with Sb (density 6.62 gm/cm<sup>3</sup>) in one-g.



**Diagram of MA-044 cartridge for alloys. Ampoule A at the hot end (bottom of furnace in Fig. 3.1) reached the highest temperature. Ampoule B near the center reached a lower temperature because the temperature decreased from left to right along the cartridge. The copper around Ampoule B is a good heat conductor and served to keep the entire ampoule at the same temperature. Ampoules A and B and their contents are shown in more detail in the diagrams at the bottom.**

**Figure 3.3**

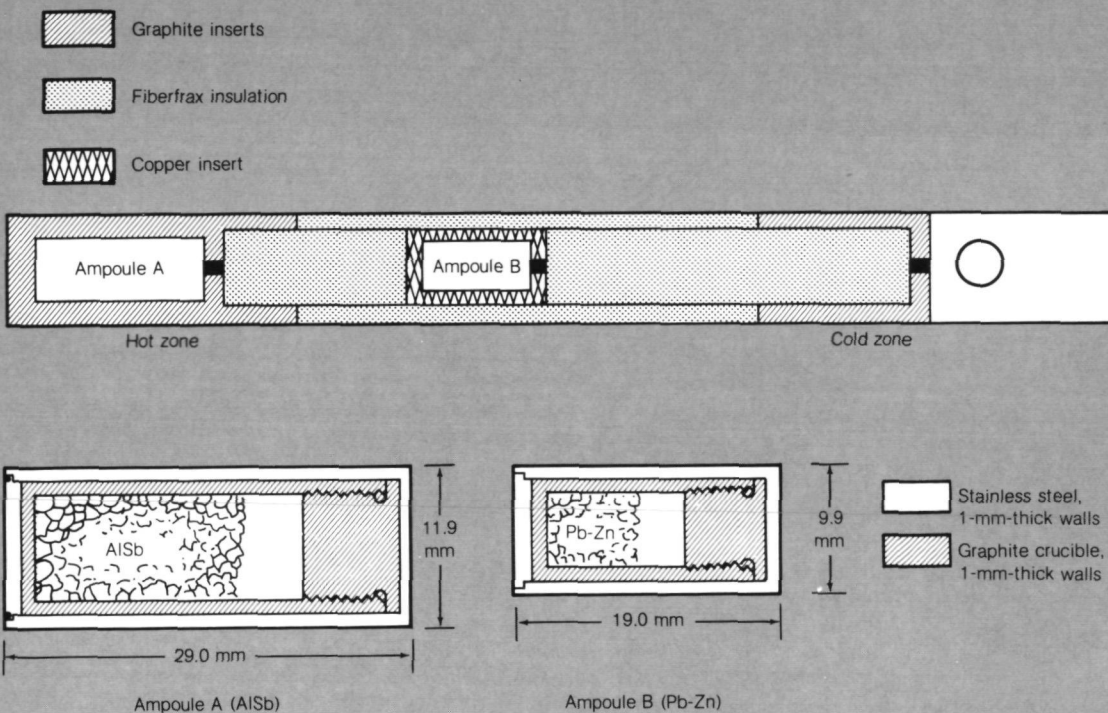

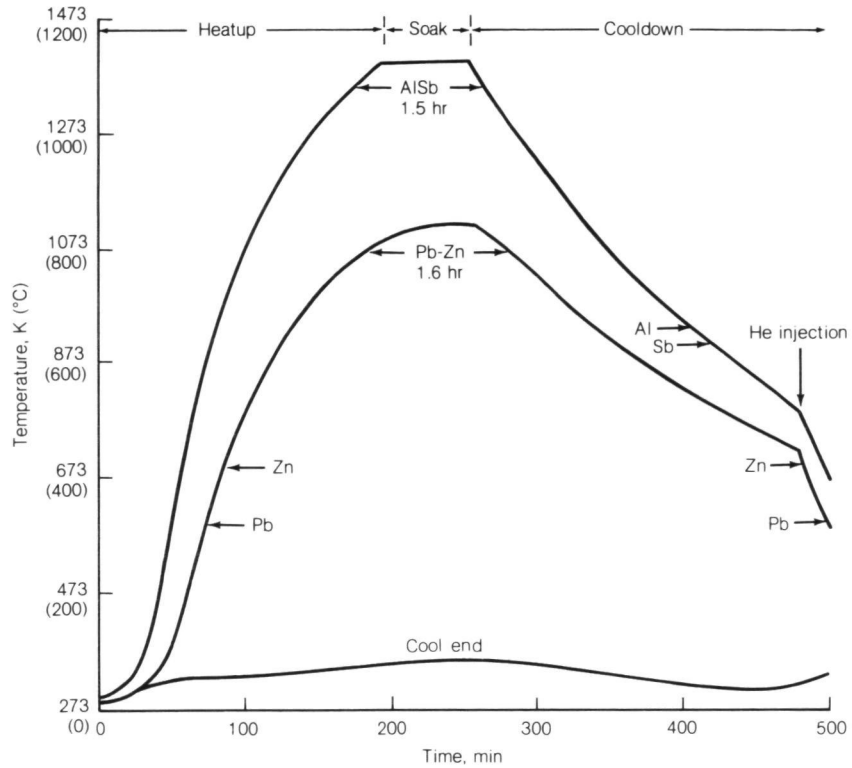

**Figure 3.4** Temperature versus time in the MA-044 cartridges. The top curve is for Ampoule A (at the hot end in Fig. 3.3); the lower curve is for Ampoule B; and the bottom curve is for the cool end of the cartridge. The horizontal arrows show the melting points of the four metals, the AlSb compound, and the Pb-Zn alloy.

If they are not perfectly mixed, the alloy can have three different structures: (1) pure AlSb with an electrical resistivity of about  $30 \Omega\text{-cm}$  (30 ohms resistance for 1-square centimeter cross section per centimeter of length), (2) a mix of Al with AlSb with a resistivity of about  $10^{-5} \Omega\text{-cm}$ , or (3) a mix of Sb with AlSb with a resistivity of about  $10^{-5} \Omega\text{-cm}$ . Pockets of the last two structures would “short out” the desired solar-cell characteristic.

Ampoule A contained 1.5 cubic centimeters of Al and Sb mixed in proportions to give exactly 50 percent Al atoms and 50 percent Sb atoms (1.26 grams of Al and 5.74 grams of Sb). This ampoule followed the higher temperature-time curve on Figure 3.4, soaking for 1.5 hours at 1423 K. Figure 3.6 shows

microscopic views of the resulting alloy: the top photograph is the flight sample cooled in zero-g and the lower photograph is a sample cooled in one-g. The red color shows the desired structure 1, pure AlSb, and the blue color shows pockets of structures 2 and 3. Many other photographs like Figure 3.6 were taken, and the area of blue (structures 2 and 3) was measured on each. In the flight samples, the pockets averaged 2 percent of the area, whereas the AlSb cooled in one-g averaged 10 percent. (In Figure 3.6, these areas are 1 percent and 25 percent.) Accurate chemical and x-ray analyses confirmed these measured areas, indicating a fivefold increase in the compound AlSb cooled in zero-g over that cooled in one-g. Measurements of the electrical resistivity averaged 12  $\Omega$ -cm in the flight samples and 0.01  $\Omega$ -cm in the one-g samples.

The Principal Investigators conclude that heating and cooling Al-Sb mixtures in zero-g can produce much more uniform AlSb compounds than in one-g and that this procedure may lead to commercial production of the AlSb compound in space.

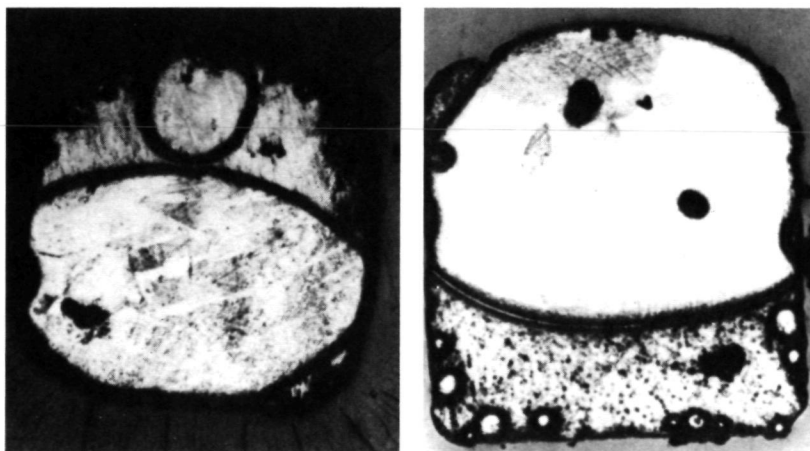

Photographs of lead-zinc ingots. In both zero-g (left) and one-g (right), the lead and zinc have not mixed.

Figure 3.5

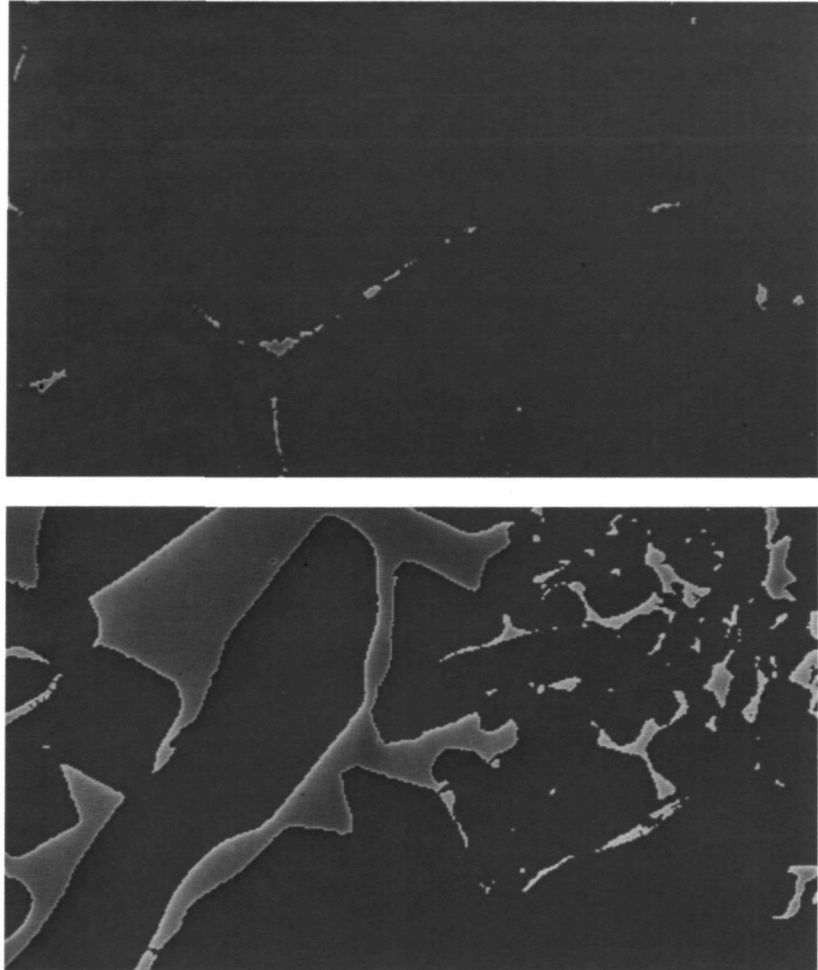
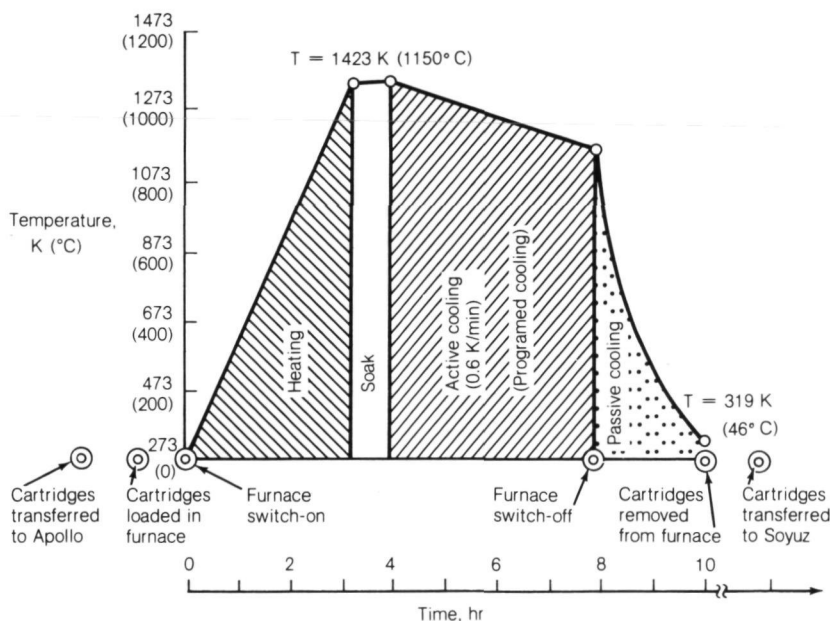

**Figure 3.6** Microstructure of AISb formed in zero-g and one-g. These enlarged photographs of polished cross sections of the AISb ingots cooled in zero-g (top) and one-g (bottom) have been colored red for pure AISb and blue for mixed structures. The defective (blue) areas total 1 percent of the area shown in the top photograph and 25 percent of the area shown in the bottom photograph.

## C Melting of Aluminum, Tungsten, Germanium, and Silicon in Zero-g

Joint Experiment MA-150 was designed by the Russian Principal Investigator, I. Ivanov, and used the American MA-010 furnace in the DM. There were three identical cartridges, each containing three ampoules, and all three cartridges were returned to the U.S.S.R. on Soyuz. One ampoule contained aluminum powder that was melted (at 973 K, or 700° C) in an attempt to produce perfect spheres when the melt was cooled. Spheres were produced, but aluminum oxide influenced their formation and they were not perfect; they were about the same as spheres produced in one-g.

The temperature-time plot selected by the Russians for the hot ends of the three cartridges is shown in Figure 3.7. The ampoule that received the full 1423-K temperature for an hour-long soak contained tungsten spheres and aluminum. In one-g, the unmelted tungsten spheres would sink to the bottom. In zero-g, they remained in place, and the Russian scientists measured the rate of formation of tungsten-aluminum alloys during the 1-hour soak.



**Figure 3.7** Temperature versus time in the Soviet materials melting experiment. The ampoules at the hot end produced an aluminum-tungsten alloy. Other ampoules reached lower soak temperatures and produced germanium crystals and aluminum spheres.



The middle ampoule reached somewhat lower temperature. It contained germanium “doped” with 2 percent of silicon atoms—a semiconductor used in electronic circuits. The melt solidified directionally, from the cool end toward the hot end of the cartridge. The Russians consider these germanium silicon crystals to be better than those made in one-g.

## D Diffusion of Gold Into Molten Lead

The diffusion of one liquid metal into another is important for metallurgical engineers who make alloys. In one-g, measurements of how fast one liquid metal spreads through another are complicated by convection currents. The hotter parts have lower density, so they rise. The cooler parts of the liquids have higher density and so they fall. In zero-g, this type of convection does not occur, but other forces (Sec. 2A) may cause currents in liquid metals. Cohesive forces of different materials produce *surface tension*, which can cause motion of the liquids at an interface between two liquids. Adhesive forces produce *wetting*, which can cause motion of a liquid along its interface with a solid. The objective of the MA-041 Experiment was to measure both these motions in the absence of gravity-produced convection.

The MA-041 scientists at the Oak Ridge National Laboratory had an effective method for measuring the amount of gold (Au) that had moved into the liquid lead (Pb) before it cooled and solidified. The small ingots returned from Apollo-Soyuz were placed in the nuclear reactor at Oak Ridge, where they were bombarded by slow neutrons. Slow neutrons cause a nuclear reaction whereby  $^{197}\text{Au}$  atoms (ordinary gold) become radioactive  $^{198}\text{Au}$  atoms, which in turn emit beta rays of 0.96-megaelectronvolt energy. The half-life of  $^{198}\text{Au}$  is 64.8 hours, sufficiently long to allow measurements of Au atoms that had moved various distances into the Pb. The small ingots were cut in half, polished, and irradiated with neutrons. The flat faces were then placed on photographic plates with a special emulsion that is sensitive to the 0.96-megaelectronvolt electrons emitted by the  $^{198}\text{Au}$  atoms. When the plate was developed, its density (blackness) showed just how many  $^{198}\text{Au}$  atoms were at each place in a thin layer of the specimen. Because the range (distance traveled) of the 0.96-megaelectronvolt electron in Pb is approximately 0.4 millimeter, only the Au concentration in this 0.4-millimeter-layer thickness is detected.

Two small ingots of lead 3 centimeters long with a 3-millimeter plate of Pb-Au alloy at the end were carried in each of three MA-041 cartridges for the MA-010 furnace. One ingot was placed at the hot end and soaked at 923 K (650° C) for 1 hour. The second was placed halfway down the cartridge, where the temperature reached 723 K (450° C), for the 1-hour soak. (Lead

melts at 600 K, or 327° C.) In the first cartridge, the lead ingots were surrounded by steel that was wetted by molten Pb; in the other two cartridges, the lead was surrounded by graphite that was *not* wetted by molten Pb. A similar set of three cartridges was heated in the same way at Oak Ridge in one-g.

Measurement of the zero-g specimens showed that the Au atoms had moved more than 1 centimeter in the lower temperature zone (723 K) and more than 2 centimeters in the higher temperature zone (923 K). The Au atoms moved the entire length of the Pb in the one-g specimens. In the zero-g ampoules, the motion was mainly down the center; there was less motion next to the walls. The motion of the Au atoms into the Pb was caused by diffusion and by currents due to surface tension. Further experiments are needed to separate these two types of motion. The Au movement in the one-g specimens was mostly due to convection.

In zero-g, the effect of wetting the steel ampoule was less than expected; that is, the motion of the Au into the Pb was very similar to that in the nonwetting graphite ampoules. In one-g, there was a small wetting effect, but it was much less than predicted. The many measurements in zero-g seem to indicate that liquid metal "slipped" along both the graphite and the steel walls and did not wet the steel walls.

## E Magnetic Alloys Formed in Zero-g

Physicists have found that magnets are made up of many small magnetic "domains," each with a north and south magnetic pole. In an ordinary bar of iron, these magnetic domains are pointing every which way (and tend to *cancel* each other's magnetic fields); however, if the bar is put into a strong magnetic field (close to another magnet or in a coil of wire carrying direct-current electricity), the domains are aligned and the iron bar is magnetized. For a *permanent* magnet, the domains must remain aligned, held there by forces in the material. In a pure iron bar, such forces are very small, and the domains lose their alignment as soon as the outside magnetic field is removed. However, some alloys have been shown to have much larger internal forces to hold magnetic alignment. The force holding the domains in line is measured by the magnetic-field strength necessary to turn them around. This is called the "coercive force." It is low for iron, which indicates how easily the magnetic alignment can be changed in iron. Coercive force is very high in some magnetic alloys.

One objective of Experiment MA-070, Zero-g Processing of Magnets, was to make magnets of very high coercive force by forming long, thin fibers of magnetic material aligned in a "matrix" of some other material, such as

bismuth, which surrounds the fibers. The idea was that the fibers would be as thin as the magnetic domains they contain. When the domains are aligned along the fibers, the matrix would tend to hold them that way.

Thin fibers are formed along the temperature gradient (direction from cool to hot) when certain molten alloys are cooled progressively from one end to the other. Figure 3.8 shows how this was done in the MA-010 furnace. The three MA-070 cartridges each contained three ampoules. Ampoule 1 at the hot end was surrounded by a graphite "heat leveler." The ampoule was heated uniformly (no temperature gradient) and contained a mix of 50-percent bismuth (Bi) atoms and 50-percent manganese (Mn) atoms. Ampoules 2 and 3 were in a strong temperature gradient of 30 K/cm (30° C/cm) down to the lower temperature at the cool end of the cartridge. Ampoule 2 was filled with a mix of copper and copper-cobalt-cerium (Cu-(CuCo)<sub>5</sub>Ce), and Ampoule 3 was filled with a mix of bismuth manganese-bismuth (Bi-MnBi).

The temperature at the hot end of the MA-070 cartridge (Ampoule 1) was raised to 1348 K (1075° C) and kept there for 45 minutes. The furnace was then allowed to cool slowly to 673 K (400° C) over 10.5 hours to solidify the mix, and then cooled quickly by inserting helium gas. The temperatures in Ampoules 2 and 3 were lower but followed the same pattern. The high of 1323 K (1050° C) in Ampoule 2 and 1123 K (850° C) in Ampoule 3 melted their contents. The cooling was from right to left in order to produce fibers along the axis in Ampoules 2 and 3.

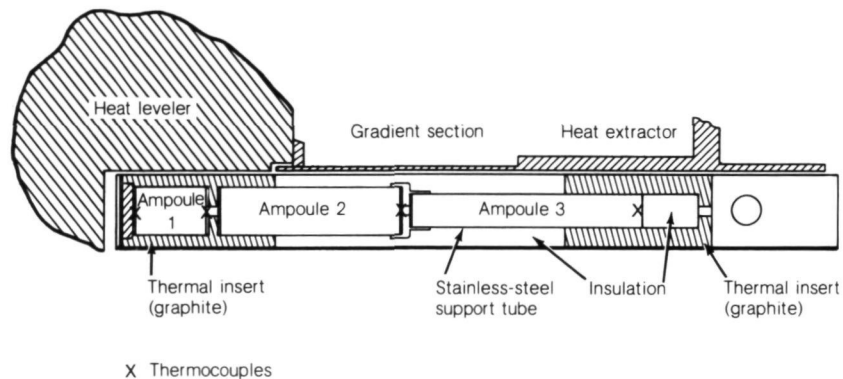

**Figure 3.8** Diagram of MA-070 cartridge for magnetic alloys. The heat leveler at the left is at the hot (bottom) end of the MA-010 furnace, and the heat extractor at the right is at the cool (top) end. The three ampoules contained different mixes for heating and cooling, Ampoules 2 and 3 in strong temperature gradients. The directional cooling was intended to form eutectic fibers in Ampoules 2 and 3.

ORIGINAL PAGE IS  
OF POOR QUALITY

The melt in Ampoule 1 cooled in zero-g to produce large, uniform MnBi crystals. (In one-g, most of the Mn rises (floats) to the top, and the few crystals produced are small.) The array of separate MnBi crystals showed that there was a temperature gradient during the cooling from the edge to the center of the cylindrical ampoule. As a result, the magnetic properties of the MnBi are complex, showing both low and high coercive forces.

In Ampoule 2, the  $\text{Cu}-(\text{CuCo})_5\text{Ce}$  mix reacted with the ampoule walls (made of boron nitride) and solidified in long crystals extending inward from the walls. The coercive force was not increased in the zero-g samples.

Near the cool end of Ampoule 3, the MnBi fibers were not well aligned, but as the cooling front proceeded toward the hot end, the fiber alignment steadily improved, as shown in Figure 3.9. The coercive strength of these samples was  $87.6 \times 10^4$  amperes/meter ( $1.1 \times 10^4$  oersteds)—more than twice as high as measured in MnBi-Bi eutectic formed in one-g. This is an important result and may lead to a new technology of manufacturing magnets.

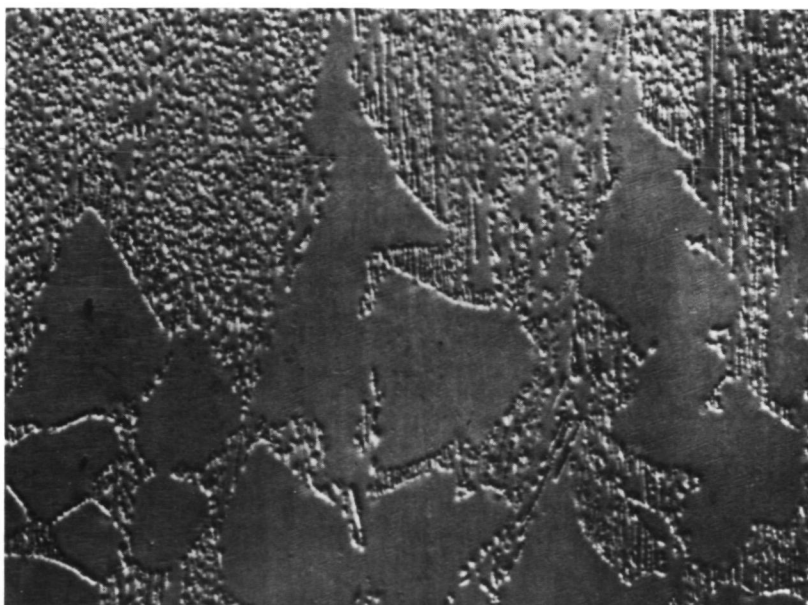

Fibers in magnetic eutectic from Experiment MA-070. No fibers were formed in the large "chunks." The thin white lines at the top are MnBi fibers in bismuth, which shows as mottled gray in this photograph of a polished cross section.

Figure 3.9

## F Transparent Fibers From a Eutectic

Transparent fibers have an important use as “light pipes” in the new technology of fiber optics. An experiment on Skylab produced long fibers of sodium fluoride (NaF) in sodium chloride (NaCl, common salt) when a mix of these two substances was melted at about 1143 K (870° C) and then cooled progressively from one end of the cartridge to the other. Experiment MA-131 tried to produce a similar eutectic made of lithium fluoride (LiF) in NaCl on Apollo-Soyuz.

The MA-131 scientists constructed nine cartridges with the dimensions shown in Figure 3.10. The sample was 29-percent LiF and 71-percent NaCl, melted and solidified in a laboratory, then carefully cut to fit inside a graphite cylinder, which was encased in a stainless-steel cylinder 111 millimeters long and 9.6 millimeters in diameter. There was a 43-millimeter empty section (filled only with inert gas) at the hot end to allow for thermal expansion during heating. The hot end was heated to 1293 K (1020° C) in the MA-010 furnace. At that point, there was a temperature gradient of 50 K/cm (50° C/cm) down the cartridge toward the cool end, and the last 12 millimeters of salt mix at the cool end was unmelted because the temperature there was less than 1073 K (800° C), the melting point of NaCl. As the mix cooled (at 0.6 K/min, or 0.6° C/min), fibers of LiF grew out into the molten mix because LiF “freezes” at 1143 K. These fibers grew steadily at a rate of about 2  $\mu\text{m}/\text{sec}$  during the next 20 hours. Back on Earth after the mission, the solidified NaCl-LiF eutectic was analyzed for fiber length, diameter, spacing, and optical properties.

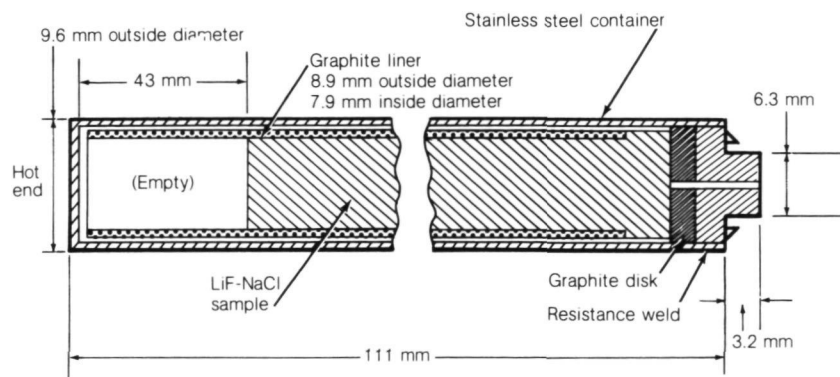

**Figure 3.10** Diagram of MA-131 cartridge for NaCl-LiF eutectic. There was a strong temperature gradient of 50 K/cm from the hot end at the left to the cool end at the right. Fibers of LiF grew from the cool end toward the hot end.

Three of the MA-131 cartridges were flown on Apollo-Soyuz to be melted and refrozen in zero-g. Three other cartridges went through the same temperatures at Westinghouse Laboratories in one-g, and three were kept by the MA-131 scientists at UCLA. The main results were a comparison between the first two sets—the fibers grown in zero-g and those grown in one-g. Figure 3.11 shows the zero-g fibers at the place where the salt mix was unmelted (left). There was a slight bulge in this unmelted surface, and the fibers grew perpendicular to the surface, bowing outward rather than growing straight down the cartridge as intended. Figure 3.12 shows the LiF fibers farther down, where the temperature gradient was more uniform and the fibers are more nearly parallel. The zero-g fibers in Figure 3.12 (top) are long (more than 1 millimeter), whereas the one-g fibers (bottom) are short (0.05 millimeter and less). Figure 3.13 shows the remarkably regular spacing and 4-micrometer diameter of the LiF fibers.

The NaCl-LiF eutectic will be useful for optical work with infrared light. The LiF fibers transmit infrared light of wavelengths from 3 to 12 micrometers. The long fibers grown in zero-g are about twice as efficient for infrared

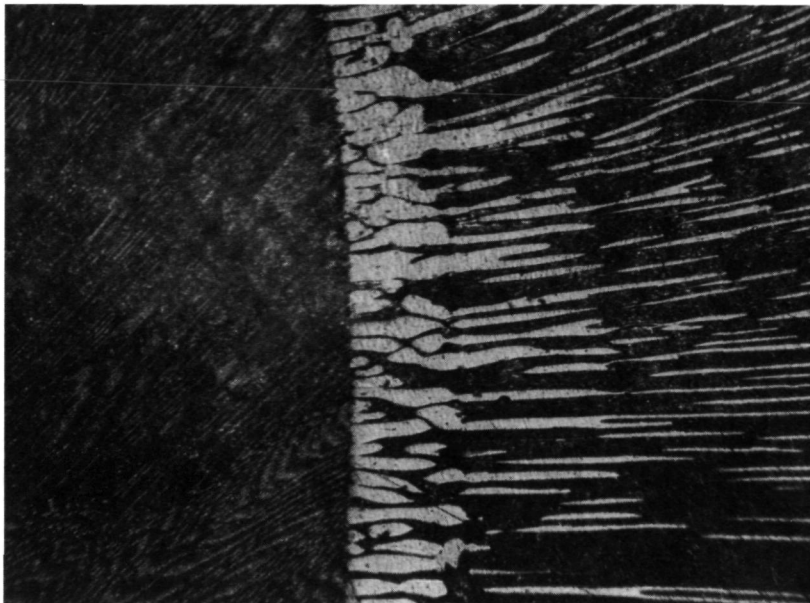

LiF fibers at the unmelted salt boundary in Experiment MA-131. The unmelted salt is on the left side.

Figure 3.11



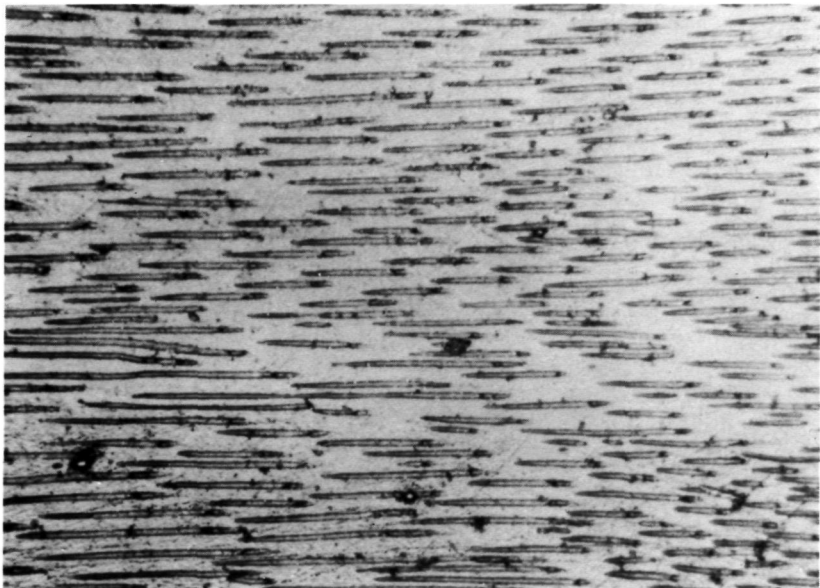
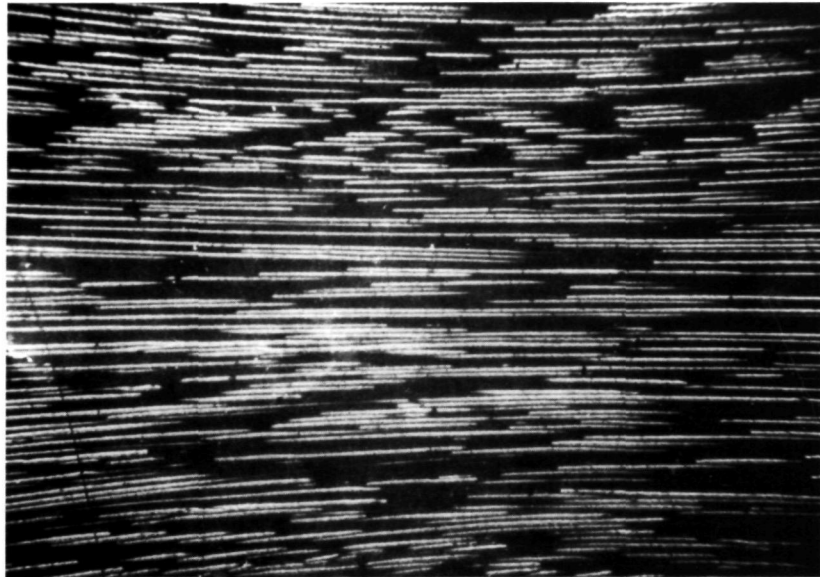

**Figure 3.12** Parallel LiF fibers formed in zero-g and one-g. The fibers formed in zero-g (top) are more than 1 millimeter long in this photograph of a lengthwise cut through the eutectic bar, enlarged 56 times. Fibers formed in one-g (bottom) are less than 0.05 millimeter long in this 210-times enlargement.

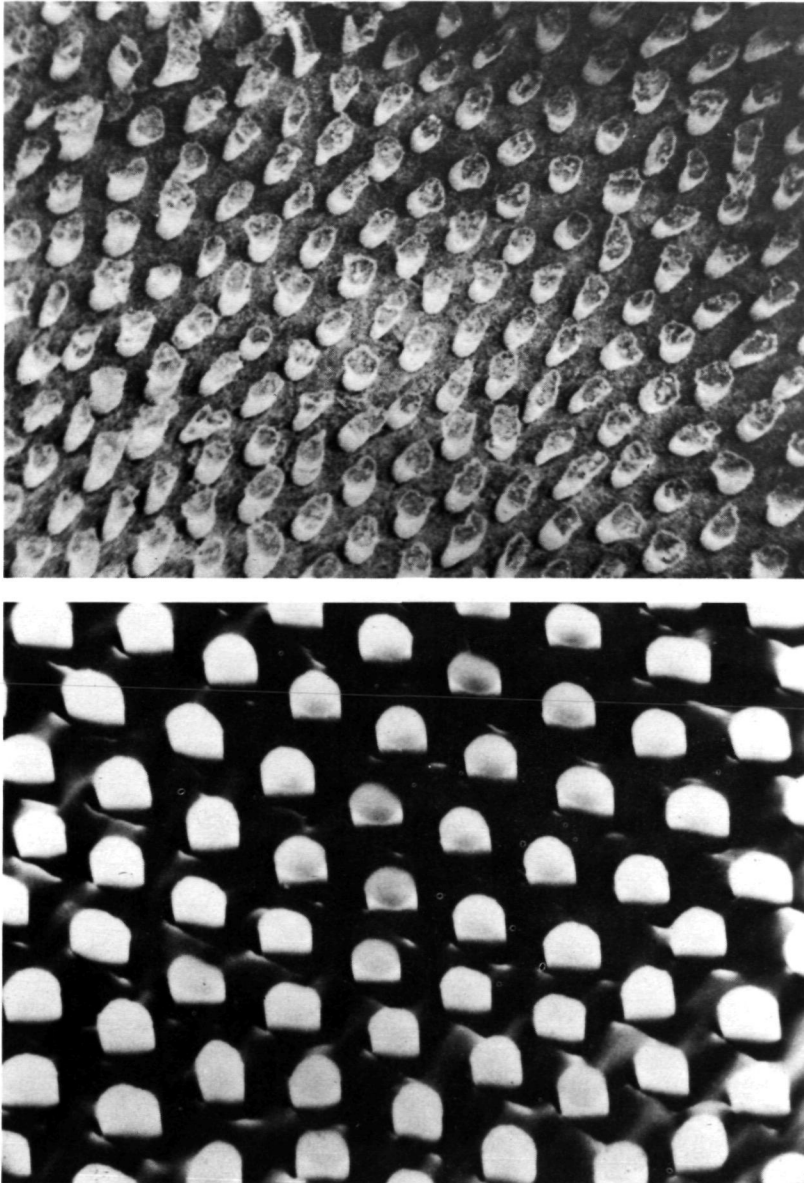

Cross sections of fibers in NaCl-LiF eutectic. The fibers are regularly spaced both in the one-g (top) and zero-g (bottom) samples. The 1900-times enlargement of the zero-g sample shows the remarkable uniformity of fiber sizes.

Figure 3.13

fiber optics as the shorter one-g fibers. When infrared light goes through the eutectic crosswise (perpendicular to the fibers), it is scattered and polarized by the fibers; that is, infrared waves oscillating *in the direction of the fibers* get through more easily than the waves oscillating *across the fibers*. The NaCl-LiF eutectic plates, cut so that the fibers are parallel to the faces, can be used as infrared polarizers (like Polaroid is used for visible light).

## G Questions for Discussion

(Heat Transport, Temperature, Alloys, Eutectics)

4. If the MA-010 furnace uses 205 watts and takes 3 hours to reach maximum temperature, what amount of energy is added to the contents of the furnace? Where did the heat go during the cooling of the furnace?

5. If the cartridge used in one experiment were twice as massive as the cartridge used in another experiment, how would the heatup times differ? The cooldown times?

6. Which furnace experiments required a temperature gradient in their samples? Which required uniform temperature?

7. How can the cartridge design give a higher or a lower temperature gradient?

8. How much power was required for the electric furnace during the soak periods at constant temperature?

9. How does a vacuum in the MA-010 furnace case reduce heat loss?

10. What should cause diffusion of one liquid metal into another where they are in contact at high temperature in the MA-010 furnace?

11. In a 50/50 mix of the atoms of two elements, what ratio of masses must be used?

12. The physical properties of an isotropic substance do not vary with direction. By what means were *nonisotropic* (anisotropic) substances formed in the MA-010 furnace?

13. How would it be possible to get more detailed data on the motions of gold through liquid lead—more like a motion picture than the beta-ray pictures of Experiment MA-041? (Remember that radioactive  $^{198}\text{Au}$  has a half-life of 64.8 hours and that furnace heatup and cooldown times are at least 3 hours.)

**14.** Long, continuous LiF fibers were important in Experiment MA-131. Were long fibers of MnBi needed in Experiment MA-070 for permanent magnets?

**Page Intentionally Left Blank**

# 4 Growing Large, Nearly Perfect Crystals in Zero-g

Crystals are solids in which most of the atoms are arranged in a regular pattern like a stack of bricks. As a crystal grows, interatomic forces ideally add another layer of "bricks" precisely placed on the ones already there. Crystals can be grown by combining substances in a solution, by freezing a liquid, or by condensing a vapor on a solid. For instance, you can see salt crystals form in salt water as it dries or ice crystals form in freezing water. Truly perfect crystals probably do not exist. The solution, or melt, or vapor is usually stirred, or is not uniform, or is moving irregularly so that a growing crystal becomes uneven and a jumble of small crystals results. Even when one crystal grows to a fairly large size, it generally develops imperfections in its layers when some other kind of atom is deposited—like an oversize brick in a stack of bricks. Then the regular layers of bricks get out of step with the layers beneath, and there is a "structural defect" in the crystal.

Crystals have become important in modern technology. For instance, the hardness of diamonds (carbon crystals) makes them valuable for use in drill bits, and germanium crystals are used in detecting gamma rays (see Pamphlet II). Many other crystals are used in electronics—crystal oscillators, solid-state rectifiers, and other semiconductors. Scientists and engineers have made great progress in growing large crystals under carefully controlled conditions, but convection currents in one-g often produce changes in the regularity of growth. These changes result in compositional and structural defects. For this reason, crystal-growth experiments were made in zero-g on Skylab in 1973, and the results were so promising that three experiments were scheduled on Apollo-Soyuz, two of them in the MA-010 furnace.

## A Growth of Large Germanium Crystals

Experiment MA-060 followed a Skylab experiment that produced crystals of indium antimonide (InSb) that were more nearly perfect than any produced on Earth. The scientists at MIT wanted to determine whether other motions due to surface tension or wetting would disorganize germanium (Ge) crystal growth in zero-g, exactly how fast such crystals grow, and what happens when the germanium is "doped" with the 1 percent of gallium (Ga) needed for electronics use. They had developed a method of "interface demarcation" to check growth rate. A layer of atoms at the crystal surface was "marked" every 4 seconds by sending a pulse of electricity (30 amperes for 90 milliseconds) from the growing crystal (+) into the molten Ge (-). Slices of the crystal were later etched with strong acids (nitric acid,  $\text{HNO}_3$ , and hydrofluoric acid, HF), which showed a fine line where the crystal interface was at the time of each electric pulse. (See Fig. 4.2.)

The MA-060 cartridge containing a 10-centimeter cylinder of Ge doped with Ga in a quartz tube is shown in Figure 4.1. At each end of the Ge were tightly fitting graphite caps attached to electrical leads for the pulses of electricity. On Apollo-Soyuz, the hot ends of three of these cartridges were heated in the MA-010 furnace to 1393 K (1120° C) so that the Ge was melted down to about 3.5 centimeters from the cool ends. The cartridges were kept this way ("soaked") for 2 hours. Then the temperature was lowered at the rate of 2.4 K/min (2.4° C/min) for more than an hour to grow the Ge crystals at about 5  $\mu\text{m}/\text{sec}$ . The furnace current was then switched off, which allowed a somewhat faster cooling rate for another hour. Then helium was inserted for fast cooldown.

After the mission, the cartridge was opened at MIT. The Ge crystal slipped easily out of the quartz tube, which shows that Ge does not wet quartz in zero-g. For some reason, this is a change from one-g, where liquid Ge *does* wet quartz and adheres to it as it solidifies. In one cartridge, where the Ge was packed with one flat crystal surface across the quartz tube at the cool end, there was a single almost perfect crystal, 6.5 centimeters long, formed from the melt. (In ground-based experiments, the longest single crystal obtained was 3 centimeters. Beyond that length, the crystal grew in "grains," with its main axis in a different direction in each grain.)

The crystals were cut lengthwise into 1-millimeter slices. One face of each slice was polished flat and then etched with acid. Figure 4.2 shows the cool end of the first cartridge with unmelted Ge at the top, a narrow region where the melting was partial, and the smooth crystal at the bottom. The fine lines are demarcations of the crystal surface, produced by the current pulses at 4-second intervals. Measurement of the spaces between these lines gives the crystal growth in 4-second intervals. The growth was small at first but increased rapidly. As Figure 4.3 shows, the growth rate leveled off at about 9 or 10  $\mu\text{m}/\text{sec}$ .

Although there are still some uncertainties about the effects of Ga "dopant" and its spread throughout the Ge crystal, the MA-060 results show that large, nearly perfect crystals can be grown from a melt in zero-g, and the growth rate of germanium in directional solidification was measured.



Diagram of MA-060 cartridge for germanium crystal growth. The germanium was inside a quartz tube with graphite "cups" at the ends for electrical contacts. One platinum wire for the electric pulses runs below the quartz tube to the hot end and inside the tube to the graphite cup.

Figure 4.1

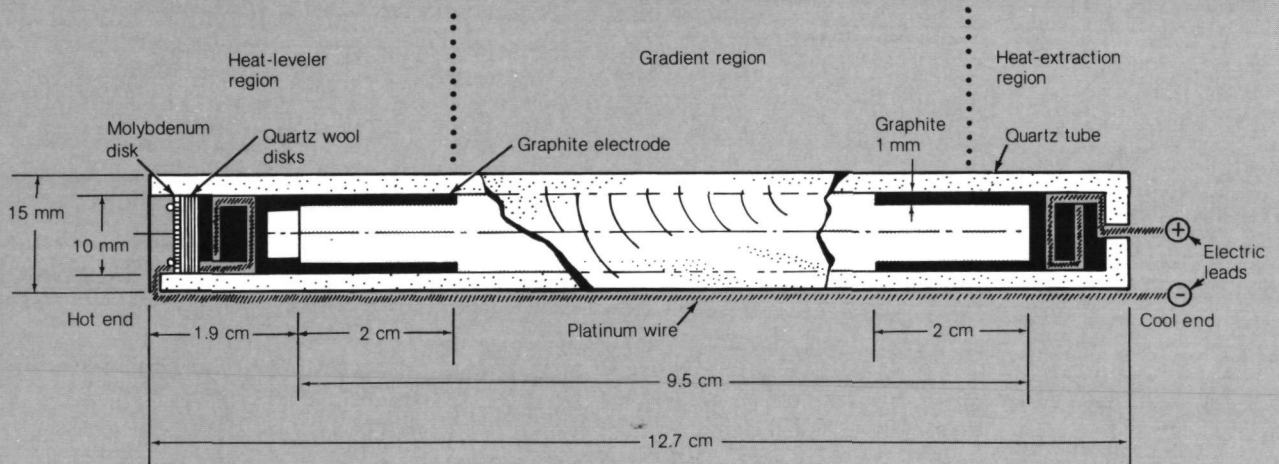

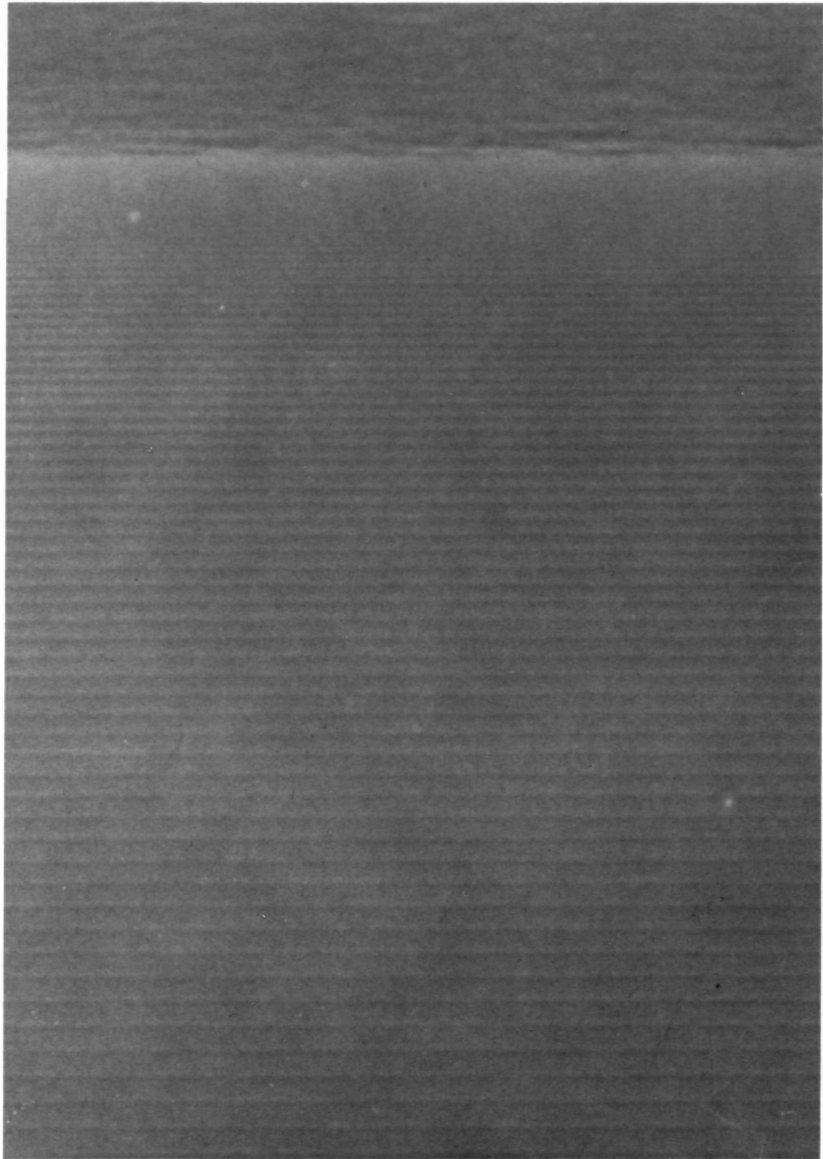

**Figure 4.2** Interface demarcation lines in germanium crystal grown in zero-g. A lengthwise slice of the crystal, polished and etched with acid, shows a line marking the crystal surface at the time of an electric current pulse. The lines are close near the unmelted germanium at the top, showing that crystal growth started slowly.

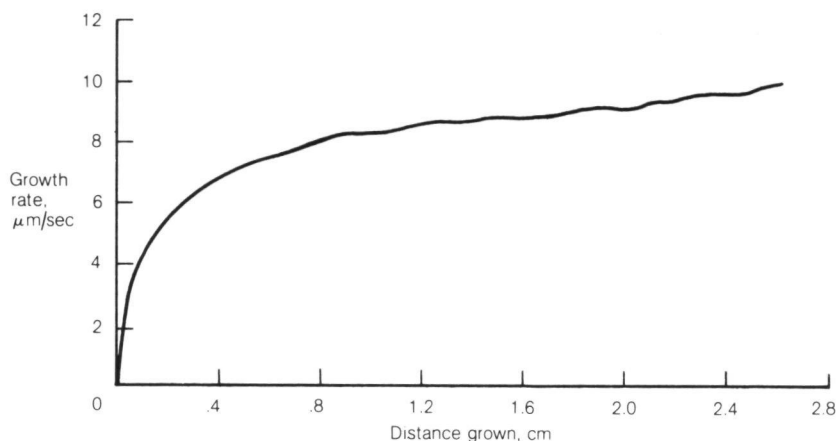

**Rate of germanium crystal growth in zero-g. The growth in 4-second intervals was measured from Figure 4.2, converted to growth rate in micrometers per second, and plotted against the distance grown (downward from the top of Fig. 4.2).**

**Figure 4.3**

## B Growth of Crystals From Vapor

Small crystals were formed at the cool end of a quartz tube from a solid (unmelted) source at the hot end by using chemical vapors as “transport agents.” This technique had been tried on Skylab in 1973 using germanium selenide (GeSe) and germanium telluride (GeTe) as the source materials and germanium iodide gas (GeI<sub>4</sub>) as the transport agent. The solids (s) were not vaporized by high temperature. Instead, they reacted with the gaseous (g) transport agent at 873 K (600° C) to give two other gases, which diffused down the tube to release GeSe or GeTe as crystals at 773 K (500° C). The chemical equations are

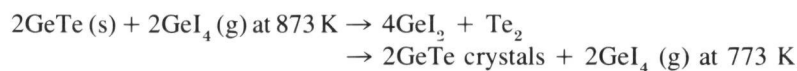
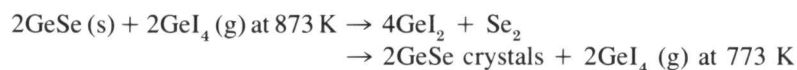

The amount of material carried by the transport agent was measured by weighing the small crystals at the cool end of the tube when it was returned to the RPI laboratory. The amount was found to be unexpectedly large. Because pure crystals of complex germanium compounds are needed for electronics, this vapor growth is an important technology. The crystals produced in zero-g are larger and more nearly perfect than those produced by the same process in one-g.

Apollo-Soyuz Experiment MA-085 confirmed the Skylab results under somewhat different conditions. Three stainless-steel cartridges for the MA-010 electric furnace contained sealed quartz tubes 15 centimeters long. At the hot end, each quartz tube had two thin silica rods that held the source material. After a 2-hour heatup period, the hot end was at 877 K (604° C) and the cool end at 780 K (507° C). These temperatures were held constant for 16 hours. Then the furnace was turned off and helium was inserted to cool the cartridges rapidly.

The source materials used in Experiment MA-085 were GeSe and germanium sulfide (GeS), and the transport agents were GeI<sub>4</sub> and germanium chloride gas (GeCl<sub>4</sub>). The cartridges, labeled A, B, and C, were loaded before the mission as follows.

<i>Cartridge</i>	<i>Source material</i>	<i>Transport agent</i>	<i>Pressure</i>
A	1.5 grams GeSe	0.123 gram GeI <sub>4</sub>	70.9 kN/m <sup>2</sup>
B	1.5 grams GeS	0.059 gram GeCl <sub>4</sub>	95.2 kN/m <sup>2</sup>
C	1.5 grams GeS	0.062 gram GeCl <sub>4</sub>	Pressurized with argon to 290.8 kN/m <sup>2</sup>

The pressures in the first two cartridges (A and B) were somewhat less than atmospheric pressure.<sup>2</sup> The third cartridge (C) was at almost three times atmospheric pressure in order to test the effect of gas density on the diffusion of the chemical vapors. In B and C, the chemical reactions were

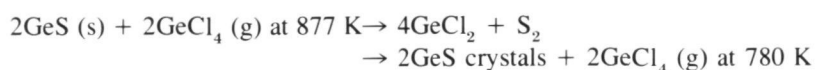

The GeCl<sub>2</sub> and S<sub>2</sub> are gases at 773 K (500° C) and above.

<sup>2</sup>One atmosphere or 760 torr is equal to 101 kN/m<sup>2</sup>.

ORIGINAL PAGE IS  
OF POOR QUALITY

When the three cartridges were returned to RPI after the Apollo-Soyuz mission, the MA-085 scientists found the quartz tube still sealed and the remaining source material still firmly attached. The small crystals that had formed at the cool end were loose, as shown in Figure 4.4. They were

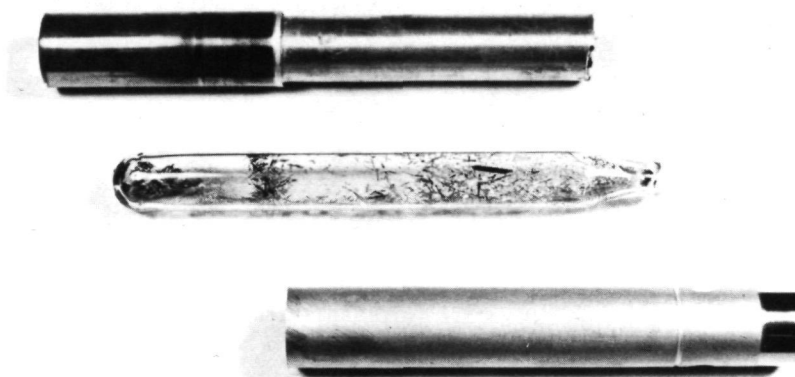

**Germanium selenide crystals formed from vapor in a quartz tube. The MA-085 quartz tube was in a cartridge heated to 877 K (604° C) at the left (hot) end and 780 K (507° C) at the cool (right) end. The GeSe at the hot end reacted with the  $\text{GeI}_4$  transport agent to form  $\text{GeI}_2$  gas and  $\text{Se}_2$  gas, which later combined to form GeSe at the cool end.**

**Figure 4.4**

collected, weighed, and analyzed by x-ray diffraction, which showed that the crystals were nearly perfect. Most of them were little plates, mixed with a few needle shapes, as shown in Figure 4.5. The total mass transported in 16 hours from the hot source to the cool end of the quartz tube was twice the predicted amount in Cartridges A and B and more than three times in Cartridge C.

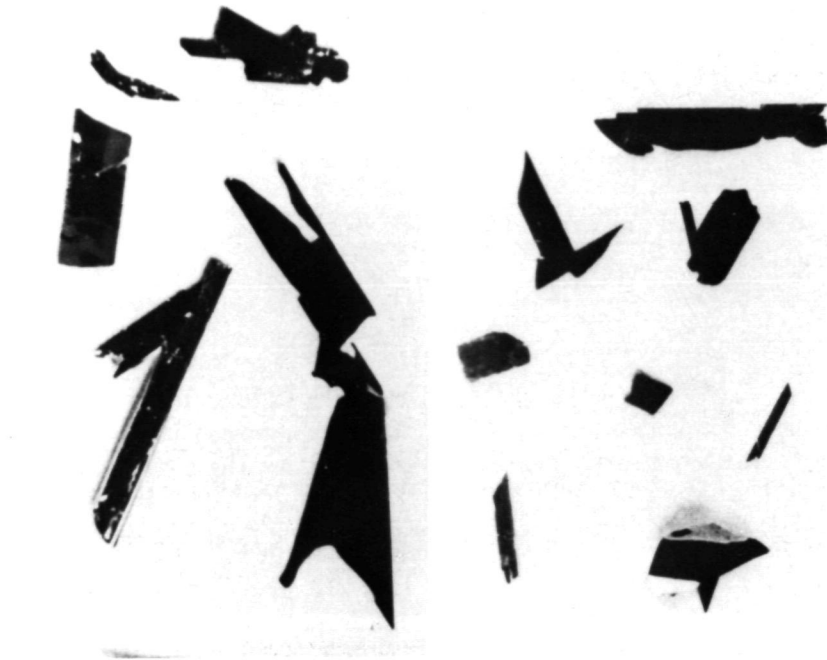
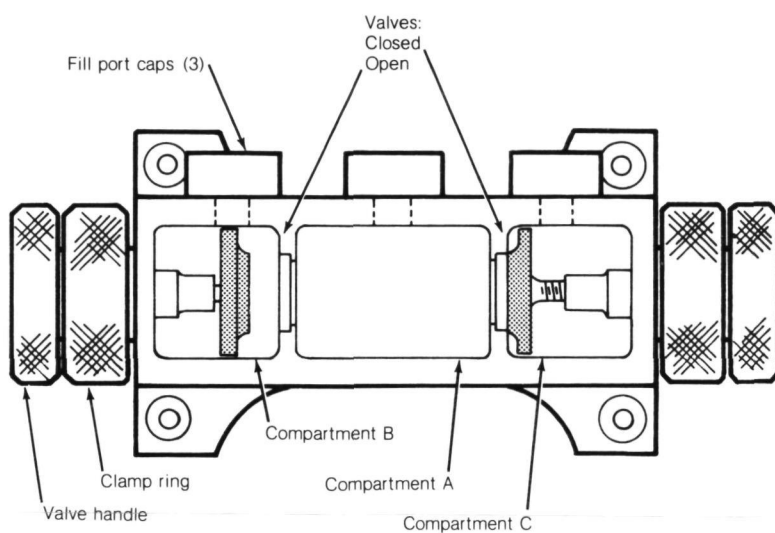

**Figure 4.5** Germanium selenide crystals formed in one-g and zero-g. Enlarged photographs of the small crystals formed in the MA-085 Experiment show that the crystals formed in one-g (left) were larger and more irregular than the crystals grown in zero-g (right).

## C Growth of Crystals From Solution

The MA-028 Crystal Growth Experiment did not use the MA-010 electric furnace. Instead, three kinds of crystals were grown in a water solution at the Apollo cabin temperature (288 to 297 K, or 15° to 24° C). The idea, a new one in zero-g crystal formation, was to release two chemicals into opposite sides of a compartment filled with water. These soluble chemicals diffuse toward each other in the water. When they meet, they react to produce an insoluble substance that forms a crystal in the water. On Earth, in one-g, each new little crystal falls to the bottom of the container. Scientists have tried to prevent this by putting a gel in the water to keep the small crystals from falling and clumping together. The soluble chemicals can diffuse through the gel, although the gel slows them. However, the gel also tends to isolate new crystals so that none of them grows very large. In zero-g, the crystals don't fall; therefore, no gel is needed and the crystals can grow to larger sizes.

A diagram of the three-compartment container for crystal growth in zero-g is shown in Figure 4.6. Compartment A was filled with pure water and was separated from Compartments B and C by valves. (In Figure 4.6, the valve to Compartment B at the left is open; the other valve is closed.) Compartments B and C were for the chemicals. On Apollo-Soyuz, when all was quiet in zero-g



**Diagram of the MA-028 reactor for forming crystals in solutions. Before launch, three compartments were filled through the "fill ports" on top. Crystals formed in Compartment A.**

**Figure 4.6**

(when there was no thruster acceleration or torquing), the two valves to Compartments B and C were opened by twisting the handles. Then the chemicals diffused slowly through the water to meet in Compartment A where crystals formed. Figure 4.7 shows six of these "reactors," each made of transparent Lexan (a plastic) so that the crystals could be seen and photographed as they formed. In four of the reactors, Compartment A was 5.08 centimeters long and 3.5 centimeters wide. In the other two reactors, Compartment A was only 4.19 centimeters long, almost 1 centimeter shorter. Each compartment had a hole covered with a screwcap so that the compartment could be filled before launch. The reactors were all bolted to a locker on the wall of the Apollo Command Module (see Pamphlet I).

The following three kinds of crystals were chosen for growth in zero-g. All of them had been studied extensively in laboratories on Earth.



1. Calcium tartrate ( $\text{CaC}_4\text{H}_4\text{O}_6 \cdot 4\text{H}_2\text{O}$ ) forms large crystals in a gel.
2. Calcium carbonate ( $\text{CaCO}_3$ ) crystals (calcite) are used in optical equipment because of their double refraction, which separates components of polarized light.
3. Lead sulfide (PbS) crystals are needed for electronics.

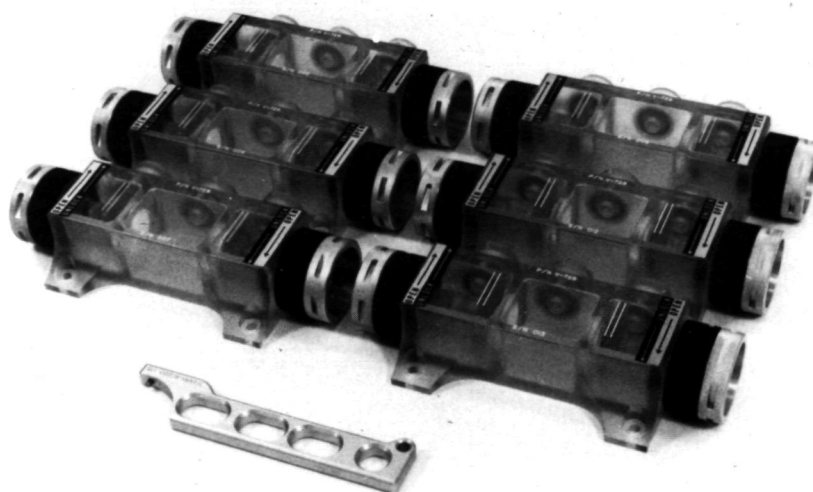

**Figure 4.7** The six MA-028 reactors for Apollo-Soyuz. Made of transparent Lexan (plastic), they were bolted to a locker in the Apollo Command Module and photographed every 12 hours after the valves were opened. The reactors were returned to the Principal Investigator after splashdown.

The reactions involved two "reactant" chemicals in each case, one in Compartment B and the other in Compartment C:

*Reaction (1)*



*Reaction (2)*

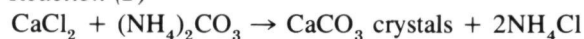

*Reaction (3)*



(Thioacetamide)

(Acetamide)

Each of these reactions was conducted in two different reactors: reactions (1) and (2) in both "long" (5.08 centimeters) and "short" (4.19 centimeters) Compartments A, and reaction (3) in the long Compartment A with the value of the water pH (acidity) adjusted to 1.0 in one reactor and to 0.5 in the other reactor by adding hydrochloric acid (HCl). These two trials of each reaction were made in order to learn what effect the length of Compartment A or the acidity of the water would have on the formation of crystals.

On the fifth day of the Apollo-Soyuz flight, the valves were opened in all six reactors, and color photographs of each reactor were taken every 12 hours with a Nikon 35-millimeter camera. These photographs show that nothing had leaked before the experiments started and that crystals formed slowly in each Compartment A during the remaining 116 hours of zero-g flight. In reactors (1) and (2), the chemical reaction had gone to completion before splashdown; that is, no more crystals were being formed. In reactor (3), PbS crystals were still forming just before splashdown and PbS sediment continued to form in one-g.

The calcium tartrate crystals produced by reaction (1) are shown in the top photograph in Figure 4.8. Some of the crystals are 5 millimeters long. They are larger than crystals produced in gel at one-g, and more of them are plate shaped rather than prism shaped. The smaller calcite crystals of reaction (2) are shown in the bottom photograph. Many of these crystals are about 0.5 millimeter on an edge and of rhombohedral shape. The PbS crystals were all small (less than 0.1 millimeter).

The MA-028 Experiment was the first attempt to grow crystals from chemical solutions in zero-g. It is hoped that reactor design and temperature control can be improved so that larger crystals can be grown in future spaceflights.

ORIGINAL PAGE IS  
OF POOR QUALITY

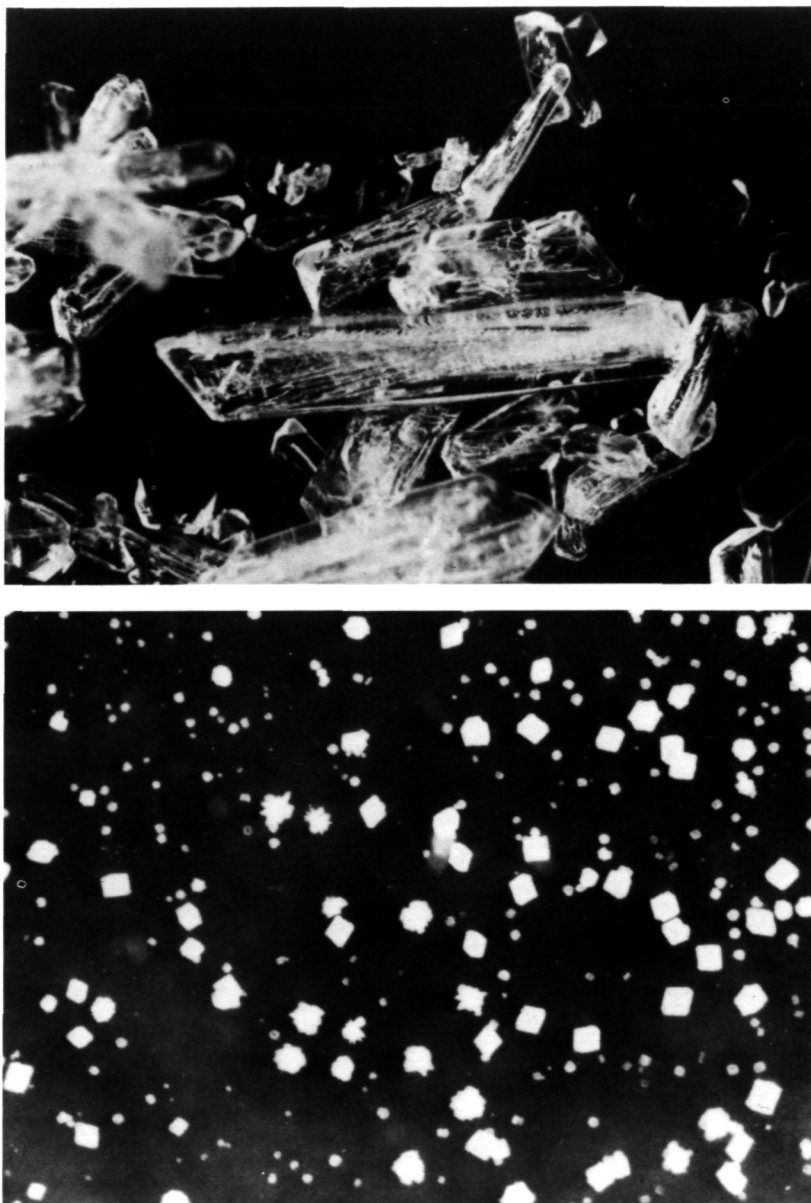

**Figure 4.8** Crystals of calcium tartrate and calcite grown in Experiment MA-028. Some of the calcium tartrate crystals (top) are as long as 5 millimeters. The calcite (calcium carbonate) crystals (bottom) are about 0.5 millimeter across.

ORIGINAL PAGE IS  
OF POOR QUALITY

## D Questions for Discussion

(Cleavage Planes, Crystal Growth)

15. Crystals of many minerals split along "cleavage planes," which are flat or offset parallel surfaces that run straight through the crystal parallel to the layers of atoms. In the analogy of a stack of bricks (Sec. 4), how would the cleavage planes run? How does this match the "cubic structure" of a salt (NaCl) crystal?

16. Water does not wet a greased cup but it does wet an aluminum cup. If you freeze water in both these cups, will the ice stick or come out easily?

17. Platinum wire was used for the electrical leads in the MA-060 cartridge for melting germanium. Why wasn't a cheaper wire used?

18. Figure 4.3 shows that the germanium crystal started growing very slowly after the MA-010 furnace was turned off, then speeded up. Why? How would you expect the growth rate to change when the fast cooldown was started later on?

19. When moist winds blow across freezing mountain peaks, long crystals of ice form on cold rocks facing the wind. How does this formation of crystals from vapor differ from Experiment MA-085?

20. The MA-085 sealed quartz tubes contained the source material, the transport gas, and the small crystals formed at the cool end. The tubes went through 3-g deceleration during Apollo reentry and splashdown, as well as experiencing considerable vibration. How might this treatment affect the later measurements of the mass of crystals formed?

21. How might you get the crystals formed from chemical vapor in the MA-085 Experiment to grow in one place so that they would form larger crystals?

22. What could be changed in the MA-028 reactor to grow PbS crystals at a faster rate?

23. Crystals formed from chemical solutions in a gel generally show structural defects. What could cause this?

24. A few small bubbles (probably air) were inadvertently left in one of the MA-028 reactors. They had little effect on the formation of crystals, but their motions were followed on the photographs taken every 12 hours. What could be learned from these motions?

# Appendix A

## Discussion Topics (Answers to Questions)

1. (Sec. 2D) If strong metal fibers were added to foam in one-g, the weight of the fibers would probably collapse the foam. In zero-g, the foam has to bear no gravity forces, but there is a problem in dispersing the fibers throughout the foam. Another possibility is to make foams of molten metals and gas in zero-g. The solidified metal foam could be a strong structural material of low density.

2. (Sec. 2D) In zero-g, the oil wetting the cup will go over the top edge and down the outside of the cup until it covers the entire surface.

3. (Sec. 2D) The adhesive force between the oil and the wick fibers is stronger than the adhesive force between the water and the wick fibers.

4. (Sec. 3G) One watt is 1 joule/sec. There are 10 800 seconds in 3 hours. Thus, 205 watts for 3 hours is  $205 \times 10\ 800 = 2.21 \times 10^6$  joules. During cooling of the MA-010 furnace, this heat escaped into the DM and its atmosphere.

5. (Sec. 3G) Heat capacity is roughly proportional to mass, so the more massive cartridges would require about twice the heat energy in joules. The power (heat input per second) is limited to 205 watts in the MA-010 furnace, so the heatup time would be about twice as long. The same reasoning applies to the cooldown period, during which the heat loss per second is proportional to the temperature difference between the furnace and its surroundings. Hence, the cooldown time would also be about twice as long.

6. (Sec. 3G) The temperature gradient promoted solidification from the cool end toward the hot end during cooldown. This directional effect was used in the following experiments:

MA-060, Interface Markings in Crystals, for the growing of a Ge crystal from the liquid

MA-085, Crystal Growth From the Vapor Phase, for the transport of Ge compounds from the hot end to the cool end of a quartz tube

MA-070, Zero-g Processing of Magnets, for the directional solidification of MnBi-Bi eutectic with MnBi fibers

MA-131, Halide Eutectic Growth, for the directional solidification of NaCl-LiF eutectic with LiF fibers

Three furnace experiments required two or three different temperatures that were *uniform* throughout each of two or three ampoules. These *different*

temperatures came from the temperature gradient and were made uniform by heat conductors surrounding the ampoules.

MA-044, Monotectic and Syntectic Alloys, used two different temperatures for forming Al-Sb and Pb-Zn alloys.

MA-150, Multiple Material Melting, used three different temperatures for melting aluminum with tungsten, germanium with silicon, and aluminum alone.

MA-041, Surface-Tension-Induced Convection, used two different temperatures for measuring the diffusion of gold into molten lead.

One experiment that did not use the furnace required uniform temperature:

MA-028, Crystal Growth, used chemicals to grow crystals in solution and required a constant temperature.

7. (Sec. 3G) By using heat insulators surrounding the ampoule in the cartridge, the temperature gradient can be made higher. By using heat conductors, the gradient can be made lower.

8. (Sec. 3G) The MA-010 furnace insulation was improved so that only 10 watts were lost at maximum temperature. Hence, the power required for soak (to maintain the high temperature) was 10 watts.

9. (Sec. 3G) The vacuum around the three cartridges in the MA-010 furnace casing prevented heat loss by conduction and convection. Loss by radiation was prevented by silvering the sides of the vacuum chamber. The remaining (10 watts) heat loss was through the insulated support of the heater and cartridges at the top of the case in Figure 3.1.

10. (Sec. 3G) Diffusion of one fluid into another is caused by thermal motions (convection) of the fluid particles (atoms or molecules in a liquid or gas).

11. (Sec. 3G) A "50/50 mix of atoms" means equal numbers of atoms per cubic centimeter. In the aluminum-antimony (Al-Sb) mix, the atomic weights are 27 amu for Al and 122 amu for Sb. So the ratio of masses must be 27 to 122, or  $27/149 = 18.1$  percent Al and  $122/149 = 81.9$  percent Sb.

12. (Sec. 3G) By directional cooling from the cool end to the hot end, two nonisotropic substances (MnBi-Bi eutectic and NaCl-LiF eutectic) were formed.

**13.** (Sec. 3G) The Au atoms could be “frozen” in several ampoules at 3, 6, 9, 12 . . . hours after their motion into the molten Pb started. Each of these ingots should be exactly the same except for the time of Au-atom motion. Each would be exposed to the same neutron flux, cut and polished, then placed on special photographic plates for just 15 minutes. The developed plates would show the progress of Au atoms through molten Pb at 3-hour intervals.

**14.** (Sec. 3G) The purpose of the MnBi-Bi eutectic in MA-070 was to restrain magnetic domains in the MnBi fibers from turning away from the fiber direction. The length of the domain in the fiber direction is a few times its width. Hence, the MnBi fibers do *not* need to be long, but they must be parallel.

**15.** (Sec. 4D) If bricks are stacked one on top of another, there are three cleavage planes: up-down lengthwise, up-down sidewise, and horizontal. They are perpendicular to each other and can “cut out” a cube of bricks. Cleavage planes of the NaCl crystal are similar, and this type of crystal is called cubic.

**16.** (Sec. 4D) Because water wets the aluminum cup, the frozen water (ice) will stick. Water does not wet the greased cup, so the ice will come out easily.

**17.** (Sec. 4D) Platinum is very nearly inert, chemically. If copper or iron or aluminum wires had been used as electrical leads, they might have contaminated the growing germanium crystal.

**18.** (Sec. 4D) Just after the MA-010 furnace was turned off, the cooling rate was slow. As the heat conduction (10 watts) reduced the heat inside the furnace case, the temperature of the cool end of the cartridge dropped faster, and more Ge atoms froze out onto the growing crystal every second. When the fast cooldown started, the crystal growth rate increased again.

**19.** (Sec. 4D) Water vapor is converted to ice crystals on cold rocks without any chemical change. In Experiment MA-085, there was a chemical reaction between two different gases to form crystals of germanium selenide (GeSe) or germanium sulfide (GeS).

**20.** (Sec. 4D) The 3-g deceleration and inertial forces during vibration might tear off parts of the source material (GeSe), which would be added to the GeSe crystals formed at the cool end of the tube. Thus, the mass of crystals loose in the quartz tube might be higher than the mass of crystals formed during Experiment MA-085.



**21.** (Sec. 4D) If a metal plate in the cool end of the MA-085 quartz tube had been cooled below the temperature of the quartz tube, most of the crystals would have been formed on it, and these crystals might have been larger than the crystals formed in the open space.

**22.** (Sec. 4D) A shorter diffusion distance (smaller Compartment A) and a higher temperature would have reduced the reaction time so that more PbS crystals would have been formed.

**23.** (Sec. 4D) The gel can introduce contaminants. When an odd atom or molecule settles on a growing crystal surface, it may cause a displacement of the next layer—a structural defect.

**24.** (Sec. 4D) In exactly zero-g, with no thermal gradient, a bubble will remain in exactly the same place in a liquid. If the spacecraft carrying the liquid is accelerated in any direction, the bubble will move in that direction. Therefore, the observed motion of the bubble shows departure from zero-g, which might have affected the MA-028 Experiment.

# Appendix B

## SI Units Powers of 10 Symbols

---

### International System (SI) Units

Names, symbols, and conversion factors of SI units used in these pamphlets:

---

Quantity	Name of unit	Symbol	Conversion factor
Distance	meter	m	1 km = 0.621 mile 1 m = 3.28 ft 1 cm = 0.394 in. 1 mm = 0.039 in. 1 $\mu\text{m}$ = $3.9 \times 10^{-5}$ in. = $10^4 \text{ \AA}$ 1 nm = $10 \text{ \AA}$
Mass	kilogram	kg	1 tonne = 1.102 tons 1 kg = 2.20 lb 1 gm = 0.0022 lb = 0.035 oz 1 mg = $2.20 \times 10^{-6}$ lb = $3.5 \times 10^{-5}$ oz
Time	second	sec	1 yr = $3.156 \times 10^7$ sec 1 day = $8.64 \times 10^4$ sec 1 hr = 3600 sec
Temperature	kelvin	K	273 K = $0^\circ\text{C}$ = $32^\circ\text{F}$ 373 K = $100^\circ\text{C}$ = $212^\circ\text{F}$
Area	square meter	m <sup>2</sup>	1 m <sup>2</sup> = $10^4$ cm <sup>2</sup> = 10.8 ft <sup>2</sup>
Volume	cubic meter	m <sup>3</sup>	1 m <sup>3</sup> = $10^6$ cm <sup>3</sup> = 35 ft <sup>3</sup>
Frequency	hertz	Hz	1 Hz = 1 cycle/sec 1 kHz = 1000 cycles/sec 1 MHz = $10^6$ cycles/sec
Density	kilogram per cubic meter	kg/m <sup>3</sup>	1 kg/m <sup>3</sup> = 0.001 gm/cm <sup>3</sup> 1 gm/cm <sup>3</sup> = density of water
Speed, velocity	meter per second	m/sec	1 m/sec = 3.28 ft/sec 1 km/sec = 2240 mi/hr
Force	newton	N	1 N = $10^5$ dynes = 0.224 lbf

---

Quantity	Name of unit	Symbol	Conversion factor
Pressure	newton per square meter	N/m <sup>2</sup>	1 N/m <sup>2</sup> = 1.45 × 10 <sup>-4</sup> lb/in <sup>2</sup>
Energy	joule	J	1 J = 0.239 calorie
Photon energy	electronvolt	eV	1 eV = 1.60 × 10 <sup>-19</sup> J; 1 J = 10 <sup>7</sup> erg
Power	watt	W	1 W = 1 J/sec
Atomic mass	atomic mass unit	amu	1 amu = 1.66 × 10 <sup>-27</sup> kg

#### Customary Units Used With the SI Units

Quantity	Name of unit	Symbol	Conversion factor
Wavelength of light	angstrom	Å	1 Å = 0.1 nm = 10 <sup>-10</sup> m
Acceleration of gravity	g	g	1 g = 9.8 m/sec <sup>2</sup>

---

**Unit Prefixes**

---

<b>Prefix</b>	<b>Abbreviation</b>	<b>Factor by which unit is multiplied</b>
tera	T	$10^{12}$
giga	G	$10^9$
mega	M	$10^6$
kilo	k	$10^3$
hecto	h	$10^2$
centi	c	$10^{-2}$
milli	m	$10^{-3}$
micro	$\mu$	$10^{-6}$
nano	n	$10^{-9}$
pico	p	$10^{-12}$

---

**Powers of 10**

---

**Increasing**

$10^2 = 100$

$10^3 = 1\ 000$

$10^4 = 10\ 000, \text{ etc.}$

Examples:

$2 \times 10^6 = 2\ 000\ 000$

$2 \times 10^{30} = 2 \text{ followed by } 30 \text{ zeros}$

**Decreasing**

$10^{-2} = 1/100 = 0.01$

$10^{-3} = 1/1000 = 0.001$

$10^{-4} = 1/10\ 000 = 0.000\ 1, \text{ etc.}$

Example:

$5.67 \times 10^{-5} = 0.000\ 056\ 7$ 

---

# Appendix C

## Glossary

References to sections, Appendix A (answers to questions), and figures are included in the entries. Those in *italic* type are the most helpful.

**adhesive force** an attraction between two different substances at the boundary between them. (Secs. 2, 2B, 3D; App. A, no. 3)

**alloy** a uniform mix of two or more metals that have been melted together. (Secs. 1D, 3A to 3E; Figs. 3.3, 3.7, 3.8)

**aluminum (Al)** a metallic element, atomic weight 26.97, atomic number 13, valence 3, melting point 933 K (660° C), density 2.7 gm/cm<sup>3</sup>. It forms the compound AlSb with antimony. (Secs. 1D, 3B, 3C, 4D; App. A, nos. 11, 16, 17; Figs. 3.3, 3.4, 3.6, 3.7)

**ampoule** a small container in the larger cartridge heated in the MA-010 furnace. Each ampoule contained a sample to be heated, then cooled and returned to Earth. (Secs. 3B to 3E; App. A, no. 13; Figs. 3.3, 3.4, 3.7, 3.8)

**antimony (Sb)** a metallic element, atomic weight 121.76, atomic number 51, valence 3 or 5, melting point 903 K (630° C), density 6.62 gm/cm<sup>3</sup>. It forms the compound AlSb with aluminum. (Secs. 1D, 3B, 4A; App. A, no. 11; Figs. 3.3, 3.4, 3.6)

**Apollo-Soyuz** a joint U.S.-U.S.S.R. mission from July 15 to July 24, 1975. Apollo, the three-man U.S. spacecraft, consisted of the Command Module (CM) connected to the Service Module (SM) and the Docking Module (DM). For 2 days, the DM was attached to Soyuz, the two-man Soviet spacecraft. The two spacecraft were in a circular orbit inclined 51.8° to the Equator, with a 93-minute period, 222 kilometers above the Earth's surface. See Pamphlet I.

**Au** chemical symbol for gold. See *gold*.

**bismuth (Bi)** a metallic element, atomic weight 209, atomic number 83, valence 3 or 5, melting point 544 K (271° C), density 9.8 gm/cm<sup>3</sup>. (Secs. 1D, 3E; App. A, nos. 12, 14; Figs. 3.8, 3.9)

**calcite** a common mineral that occurs in many crystal shapes, among them hexagonal plates, prisms, and rhombohedrons. (Sec. 4C; Fig. 4.8)

**cartridge** a cylinder 20.5 centimeters long and 2.1 centimeters in diameter, containing one or more ampoules filled with material to be heated in the MA-010 furnace. Three cartridges fit into the furnace together. (Secs. 3A to 3F, 4A, 4B, 4D; App. A, nos. 5, 7, 9, 18; Figs. 3.1, 3.3, 3.4, 3.7, 3.8, 3.10, 4.1, 4.4)

**coercive force** the magnetic-field strength needed to demagnetize a permanent magnet. (Sec. 3E)

**cohesive force** the force at the boundary of a liquid that pulls the liquid together and causes surface tension. (Secs. 2, 2B, 3D)

**Co-Investigator** a scientist working with the Principal Investigator on a NASA experiment. (Sec. 1)

**convection** material motions in a fluid or gas. In one-g, it is the up-and-down drafts in a fluid heated from below. (Secs. 1D, 3D, 4; App. A, nos. 9, 10)

**crystal** a solid composed of atoms or ions or molecules arranged in a regular repetitive pattern. The shape of a crystal is related to this pattern. Many crystals can be split parallel to definite planes determined by this pattern (cleavage planes). (Secs. 1C, 1D, 3A, 3C, 3E, 4, 4A to 4D; App. A, nos. 15, 17 to 23; Figs. 3.7, 4.1 to 4.4, 4.5, 4.6, 4.8)

**demarcation** a method of marking layers of atoms in a crystal by using pulses of electric current during the growth of the crystal. (Sec. 4A; Fig. 4.2)

**demonstrations** experiments on Apollo-Soyuz designed to show the effects of zero-g. (Secs. 1A, 2, 2A to 2C)

**diffusion** the movement of atoms or molecules of one fluid into another fluid. Diffusion is much slower in solids. (Secs. 3B, 3D, 4B, 4C; App. A, nos. 10, 22)

**Docking Module (DM)** a special component added to the Apollo spacecraft so that it could be joined with Soyuz. See Pamphlet I.

**domains** small volumes of a magnetic material that act like magnetic units and tend to align with a magnetic field from outside. (Sec. 3E; App. A, no. 14)

**doped crystal** a crystal with a small amount of contamination. Such a crystal has important electrical properties different from those of the pure crystal. Adding a contaminating material such as silicon when the crystal is forming is called "doping." (Secs. 3C, 4A)

**eutectic** a mix of two materials that has a lower melting temperature than either material alone. When the molten mix solidifies, one material freezes in a regular pattern throughout the other. (Secs. 1D, 3A, 3F; App. A, nos. 12, 14; Figs. 3.8 to 3.10, 3.12, 3.13)

**fibers** long threads of one substance running through a matrix (another substance). Fibers can be formed by directional cooling of a molten mix. (Secs. 1D, 2, 2D, 3E to 3G; App. A, nos. 1, 14; Figs. 3.8 to 3.10; 3.11 to 3.13)

**foam** many small bubbles of gas in a liquid that has low surface tension (low cohesive force). (Secs. 2, 2A, 2D; App. A, no. 1; Fig. 2.1)

**gallium (Ga)** a rare metallic element, atomic weight 69.72, atomic number 31, valence 2 or 3, melting point 303 K (29.8° C), density 5.9 gm/cm<sup>3</sup>. (Sec. 4A)

**gel** a jellylike substance that offers little resistance to liquid diffusion but prevents fluid currents and small solid particles (crystals) from moving. (Secs. 4C, 4D; App. A, no. 23)

**germanium (Ge)** a metallic element, atomic weight 72.60, atomic number 32, valence 4, melting point 1231 K (958° C), density 5.4 gm/cm<sup>3</sup>. It is a semiconductor and forms crystals that are used in electronics. (Secs. 1C, 1D, 3C, 4 to 4B, 4D; App. A, nos. 17 to 20; Figs. 3.7, 4.1, 4.2, 4.3 to 4.5)

- gold (Au)** a metallic element, atomic weight 197.2, atomic number 79, valence 1 or 3, melting point 1336 K (1063° C), density 19.3 gm/cm<sup>3</sup>. (Secs. 1D, 3D; App. A, no. 13)
- graphite** a form of pure carbon used as a heat conductor in the MA-010 furnace. Its melting point is above 3773 K (3500° C); its density 2.3 gm/cm<sup>3</sup>; and its heat conductivity about one-fourth that of copper. (Secs. 3A, 3D to 3F, 4A; Figs. 3.3, 3.8, 3.10, 4.1)
- gravity** the downward force on a mass near the Earth, one-g on the Earth's surface. (Secs. 1C, 1D, 2, 3B, 3D; App. A, no. 1)
- helium (He)** a normally inert gaseous element, atomic weight 4.002, atomic number 2, valence 0, boiling point 4.25 K (-268.9° C). Helium has high thermal conductivity and was used to cool the MA-010 furnace. (Secs. 3A, 3E, 4A, 4B; Figs. 3.1, 3.4)
- infrared** invisible electromagnetic radiation of wavelengths from 0.7 to 1000 micrometers; longer than visible wavelengths. (Sec. 3F)
- ingot** a block of metal solidified from a melt in the MA-010 furnace. (Secs. 3B, 3D; App. A, no. 13; Figs. 3.5, 3.6)
- isotropic** the same in all directions. Uniform alloys are isotropic. Eutectics are *nonisotropic* because parallel fibers all extend in one direction. (Sec. 3G; App. A, no. 12)
- lead (Pb)** a metallic element, atomic weight 207.22, atomic number 82, valence 2 or 4, melting point 600 K (327° C), density 11.35 gm/cm<sup>3</sup>. (Secs. 1D, 3B, 3D, 4C; App. A, nos. 13, 22; Figs. 3.3 to 3.5)
- lithium fluoride (LiF)** a salt compound transparent to both far-ultraviolet and infrared rays. (Secs. 1D, 3F, 3G; App. A, no. 12; Figs. 3.10 to 3.13)
- MA-010** the Multipurpose Electric Furnace Experiment on the Apollo-Soyuz mission. (Secs. 1D, 3, 3A, 3B to 4B, 4D; App. A, nos. 4 to 6, 8 to 10, 12, 13, 18; Figs. 3.1, 3.2, 3.7)
- MA-028** the Crystal Growth Experiment. (Secs. 1C, 4C, 4D; App. A, nos. 6, 22, 24; Figs. 4.6 to 4.8)
- MA-041** the Surface-Tension-Induced Convection Experiment. (Secs. 1D, 3D, 3G; App. A, nos. 6, 13)
- MA-044** the Monotectic and Syntectic Alloys Experiment. (Secs. 1D, 3B; App. A, no. 6; Figs. 3.3, 3.4 to 3.6)
- MA-060** the Interface Markings in Crystals Experiment. (Secs. 1C, 4A, 4D; App. A, nos. 6, 17; Figs. 4.1 to 4.3)
- MA-070** the Zero-g Processing of Magnets Experiment. (Secs. 1D, 3E; App. A, nos. 6, 14; Figs. 3.8, 3.9)
- MA-085** the Crystal Growth From the Vapor Phase Experiment. (Secs. 1C, 4B, 4D; App. A, nos. 6, 19 to 21; Figs. 4.4, 4.5)
- MA-131** the Halide Eutectic Growth Experiment. (Secs. 1D, 3F, 3G; App. A, no. 6; Figs. 3.10, 3.11 to 3.13)



**MA-150** the Multiple Material Melting Joint Experiment. (Secs. 1D, 3C; App. A, no. 6; Fig. 3.7)

**magnet** a substance with the property of attracting certain other substances. Some metals (iron, cobalt, and nickel, for instance) can be magnetized to attract other magnetic metals. (Secs. 1D, 3E; Figs. 3.8, 3.9) Such a magnet has a *magnetic field*, a region around it where there are forces on other magnets. (Secs. 1, 3E) An electric current also creates a magnetic field.

**manganese (Mn)** a magnetic element, atomic weight 54.93; atomic number 25; valence 2, 3, 4, 6, or 7; melting point 1493 K (1220° C); density 7.4 gm/cm<sup>3</sup>. (Secs. 1D, 3E; App. A, nos. 12, 14; Figs. 3.8, 3.9)

**metallurgy** the study of metals and alloys. (Secs. 1, 1D, 3D)

**MIT** Massachusetts Institute of Technology, a university in Cambridge, Massachusetts.

**MSFC** the NASA George C. Marshall Space Flight Center in Huntsville, Alabama.

**NaCl** See *sodium chloride*.

**neutron** a nuclear particle with a mass slightly larger than that of a proton (hydrogen ion) but no charge. Slow neutrons easily enter the nucleus of an atom, usually producing a radioactive isotope. (Sec. 3D)

**oersted** a unit of magnetic field strength: 1 oersted = 79.58 amperes/meter. The strength of the Earth's magnetic field at the surface is about 0.5 oersted.

**ohm** a unit of electrical resistance. If a wire has a 1-ohm resistance and a 1-volt potential difference between its ends, 1 ampere of current will flow through the wire.

**one-g** the downward acceleration of gravity at the Earth's surface, 9.8 m/sec<sup>2</sup>. In an orbiting spacecraft, everything is weightless at zero-g. (Secs. 1B to 1D, 2 to 2B, 3B to 3F, 4 to 4C; App. A, no. 1; Figs. 3.5, 3.6, 3.12, 3.13, 4.5)

**Pb** chemical symbol for lead. See *lead*.

**polarized** waves that vibrate in a definite pattern. Ordinary light and infrared waves are unpolarized; they oscillate in all directions around the line of sight. "Plane-polarized" waves oscillate in one direction (in one plane), like a clothesline jiggled up and down only. (Secs. 3F, 4C)

**Principal Investigator** the individual responsible for a space experiment and for reporting the results. (Sec. 1)

**quartz (SiO<sub>2</sub>)** commonly crystalline; fused in factories to form a transparent glasslike substance (silica) with a melting point of about 1973 K (1700° C). (Secs. 4A, 4B, 4D; App. A, nos. 20, 21; Figs. 4.1, 4.4)

**radioactive** elements and isotopes whose atoms have unstable nuclei that eject particles and emit radiation at a regular but decreasing rate. After one "half-life," half of the unstable nuclei have completed ejection and become stable. (Secs. 3D, 3G; App. A, no. 13)

**reaction** a chemical change that occurs when two or more reactants are mixed, usually in solution. (Secs. 1C, 2, 2A, 4B, 4C; App. A, nos. 19, 22; Figs. 2.1, 4.4) (Not to be confused with physical reaction—a force—and reaction motors—jets—described in Pamphlet I.)

**reactor** a transparent container for chemical reactants. The reactors on Apollo-Soyuz were photographed as the reactants produced crystals in the MA-028 Experiment. (Sec. 4C; Figs. 4.6, 4.7)

**RPI** Rensselaer Polytechnic Institute, a university in Troy, New York.

**salt** a compound such as NaCl, common table salt, formed from an acid and a base. (Secs. 1D, 3, 3F, 4; Fig. 3.11)

**Sb** chemical symbol for antimony. See *antimony*.

**selenium (Se)** a nonmetallic element; atomic weight 79.2; atomic number 34; valence 2, 4, or 6; melting point 493 K (220° C); density 4.8 gm/cm<sup>3</sup>. (App. A, no. 20; Figs. 4.4, 4.5)

**silicon (Si)** a nonmetallic element, atomic weight 28.06, atomic number 14, valence 4, melting point 1693 K (1420° C), density 2.4 gm/cm<sup>3</sup>. (Secs. 1D, 1E, 3B, 3C)

**Skylab** a very large space workshop that NASA put into orbit on May 14, 1973. It was visited by three astronaut crews who worked on scientific experiments in space for a total of 172 days, the last crew for 84 days. (Secs. 3, 3F, 4 to 4B)

**soak** in the MA-010 furnace, materials could be left to "soak" at the highest temperature for as long as 6 hours. (Secs. 3A, 3B to 3D, 4A; App. A, no. 8; Figs. 3.1, 3.2, 3.4, 3.7)

**sodium chloride (NaCl)** common salt. (Secs. 1D, 3F, 4D; App. A, nos. 12, 15; Figs. 3.10, 3.13)

**stainless steel** a corrosion-resistant alloy of iron, chromium, and a trace of carbon. It has a melting point of about 1773 K (1500° C) and was used as the cartridge casings for the MA-010 furnace. (Secs. 2C, 3B, 3F, 4B; Figs. 3.3, 3.8, 3.10)

**surface tension** the tendency of a liquid that has a large cohesive force to keep its surface as small as possible, forming spherical drops. (Secs. 1D, 3D, 4A)

**temperature gradient** the change of temperature per centimeter along a cartridge or a sample inside it. (Secs. 3E, 3F; App. A, nos. 6, 7, 24; Figs. 3.3, 3.8, 3.10, 4.1)

**tungsten (W)** a metallic element, atomic weight 184.0, atomic number 74, valence 6, melting point 3643 K (3370° C), density 18.7 gm/cm<sup>3</sup>. (Secs. 1D, 3C; Fig. 3.7)

**vacuum** the absence of gas. It is a relative term; in the "hard" vacuum of space outside Apollo-Soyuz, there were still about 10<sup>8</sup> gas atoms/cm<sup>3</sup>. (Secs. 1C, 3A; App. A, no. 9)

**Velcro** a plastic cloth of two types that stick to each other. One type has many fine, hooked spines protruding from the surface; the other type has many narrow holes or crevices in the surface. When the spines are pressed into the holes, they stick there. (Sec. 1A)

**wick** a group or braid of thin fibers that “sucks up” a liquid if the adhesive force between the fiber and the liquid is greater than the liquid’s cohesive force. (Secs. 2, 2C, 2D; App. A, no. 3; Fig. 2.3)

**zero-g** the condition of free fall or weightlessness. When there are no forces on objects in a spacecraft, they are “in zero-g.” (Secs. 1, 1A, 1B to 1D, 2 to 3, 3B to 3F; App. A, nos. 1, 2, 14; Figs. 2.1 to 2.3, 3.5, 3.6, 3.12, 3.13, 4.2, 4.3, 4.5)

**zinc (Zn)** a metallic element, atomic weight 65.38, atomic number 30, valence 2, melting point 692 K (419° C), density 7.1 gm/cm<sup>3</sup>. (Sec. 3B; Figs. 3.3 to 3.6)

# Appendix D

## Further Reading

*Ceramics, Plastics, and Metals* by Richard H. Krock and Merrill L. Ebner, D. C. Heath (Boston), 1965—an introduction to the science of solids; contains excellent diagrams.

*Crystals and Crystal Growing* by Alan Holden and Phyllis Singer, Garden City, N. Y., 1960—an Anchor paperback, part of the Science Study Series developed as part of the PSSC physics curriculum; an excellent reference on the theory and practice of crystallography.

*The Language of Space: A Dictionary of Astronautics* by Reginald Turnill, John Day Co., Inc. (New York), 1971—a well-written glossary of 1100 terms, with a section on “the next 20 years in space.”

*Metals, Atoms, and Alloys* (Vistas of Science No. 9) by Charles Law McCabe and Charles L. Bauer, McGraw-Hill Book Co., Inc. (New York), 1964—produced by the National Science Teachers Association.

*Physics for Society* by W. B. Phillips, Addison Wesley Publishing Co., Inc. (Menlo Park, Calif.), 1971—covers recent advances in technology and space science.

*Rendezvous in Space: Apollo-Soyuz* by F. Dennis Williams (Available without charge from NASA Educational Programs Division/FE, Washington, D.C. 20546), 1975—a popular account of the Apollo-Soyuz Test Project, including the U.S.-U.S.S.R. agreements.

EP-140



National Aeronautics and  
Space Administration