

Apollo-Soyuz Pamphlet No.2:

ORIGINAL PAGE IS
OF POOR QUALITY

X-Rays, Gamma-Rays

(NASA-EP-134) APOLLO-SOYUZ PAMPHLET NO. 2:
X-RAYS, GAMMA-RAYS (National Aeronautics and
Space Administration) 74 p MF A01; SOD HC
set of 9 volumes

N78-27148

CSSL 22A

Unclas

G3/12

24990

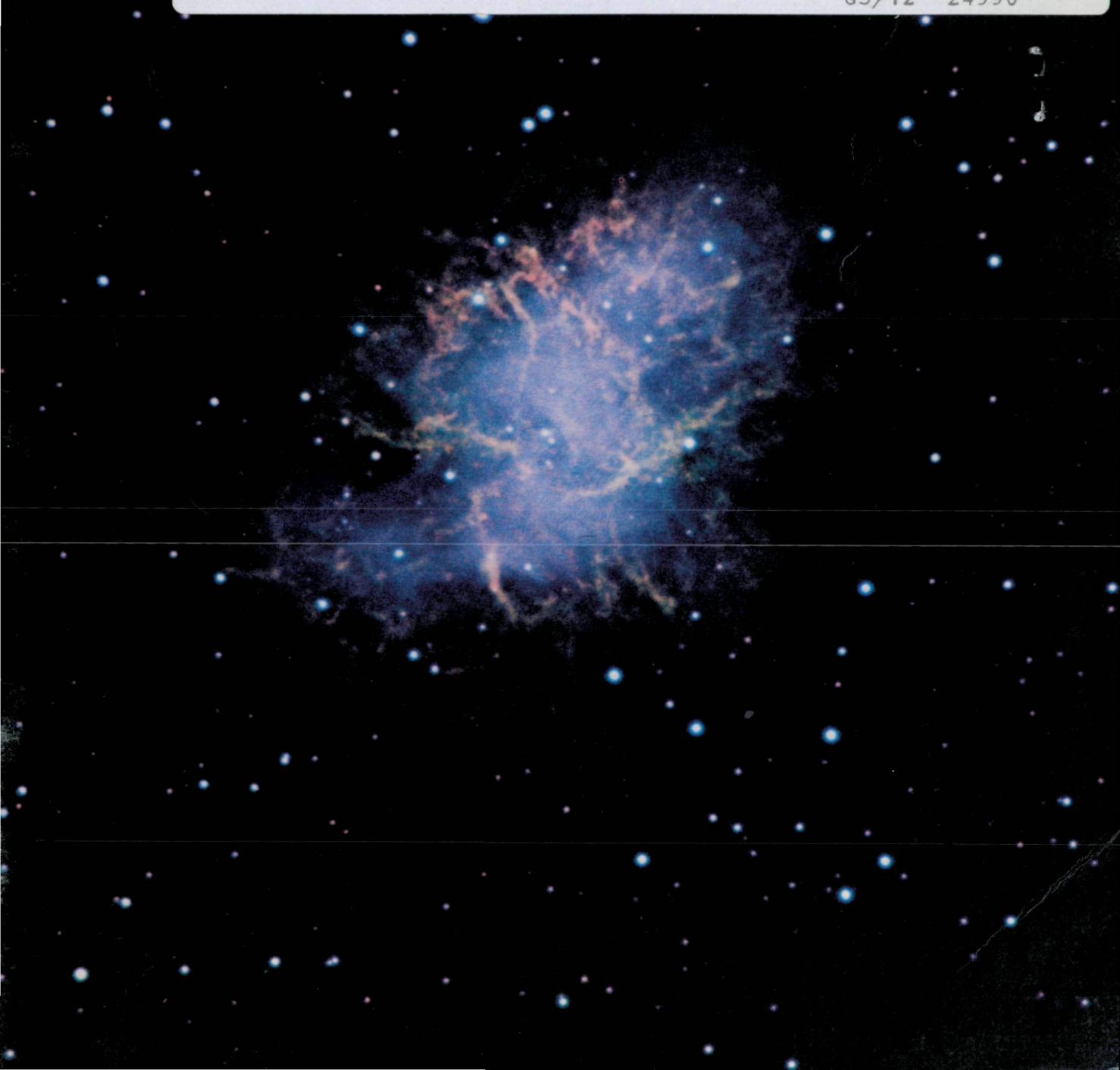

**Apollo-
Soyuz
Experiments
In
Space**

This is one of a series of nine
curriculum-related pamphlets
for Teachers and Students
of Space Science

**Titles in this series of
pamphlets include:**

- EP-133 Apollo-Soyuz Pamphlet No. 1: The Flight
- EP-134 Apollo-Soyuz Pamphlet No. 2: X-Rays, Gamma-Rays
- EP-135 Apollo-Soyuz Pamphlet No. 3: Sun, Stars, In Between
- EP-136 Apollo-Soyuz Pamphlet No. 4: Gravitational Field
- EP-137 Apollo-Soyuz Pamphlet No. 5: The Earth from Orbit
- EP-138 Apollo-Soyuz Pamphlet No. 6: Cosmic Ray Dosage
- EP-139 Apollo-Soyuz Pamphlet No. 7: Biology in Zero-G
- EP-140 Apollo-Soyuz Pamphlet No. 8: Zero-G Technology
- EP-141 Apollo-Soyuz Pamphlet No. 9: General Science

On The Cover

The Crab Nebula, a Strong X-Ray Source (Tau X-1)
Lick Observatory Photograph

Apollo-Soyuz
Pamphlet No.2:

X-Rays, Gamma-Rays

Prepared by Lou Williams Page and Thornton Page From
Investigators' Reports of Experimental Results and With
the Help of Advising Teachers

NASA

National Aeronautics and
Space Administration

Washington, D.C. 20546
October 1977

For sale by the Superintendent of Documents,
U.S. Government Printing Office, Washington, D.C. 20402
(9-Part Set; Sold in Sets Only)
Stock Number 033-800-00688-8

Preface

The Apollo-Soyuz Test Project (ASTP), which flew in July 1975, aroused considerable public interest; first, because the space rivals of the late 1950's and 1960's were working together in a joint endeavor, and second, because their mutual efforts included developing a space rescue system. The ASTP also included significant scientific experiments, the results of which can be used in teaching biology, physics, and mathematics in schools and colleges.

This series of pamphlets discussing the Apollo-Soyuz mission and experiments is a set of curriculum supplements designed for teachers, supervisors, curriculum specialists, and textbook writers as well as for the general public. Neither textbooks nor courses of study, these pamphlets are intended to provide a rich source of ideas, examples of the scientific method, pertinent references to standard textbooks, and clear descriptions of space experiments. In a sense, they may be regarded as a pioneering form of teaching aid. Seldom has there been such a forthright effort to provide, directly to teachers, curriculum-relevant reports of current scientific research. High school teachers who reviewed the texts suggested that advanced students who are interested might be assigned to study one pamphlet and report on it to the rest of the class. After class discussion, students might be assigned (without access to the pamphlet) one or more of the "Questions for Discussion" for formal or informal answers, thus stressing the application of what was previously covered in the pamphlets.

The authors of these pamphlets are Dr. Lou Williams Page, a geologist, and Dr. Thornton Page, an astronomer. Both have taught science at several universities and have published 14 books on science for schools, colleges, and the general reader, including a recent one on space science.

Technical assistance to the Pages was provided by the Apollo-Soyuz Program Scientist, Dr. R. Thomas Giuli, and by Richard R. Baldwin, W. Wilson Lauderdale, and Susan N. Montgomery, members of the group at the NASA Lyndon B. Johnson Space Center in Houston which organized the scientists' participation in the ASTP and published their reports of experimental results.

Selected teachers from high schools and universities throughout the United States reviewed the pamphlets in draft form. They suggested changes in wording, the addition of a glossary of terms unfamiliar to students, and improvements in diagrams. A list of the teachers and of the scientific investigators who reviewed the texts for accuracy follows this Preface.

This set of Apollo-Soyuz pamphlets was initiated and coordinated by Dr. Frederick B. Tuttle, Director of Educational Programs, and was supported by the NASA Apollo-Soyuz Program Office, by Leland J. Casey, Aerospace Engineer for ASTP, and by William D. Nixon, Educational Programs Officer, all of NASA Headquarters in Washington, D.C.

Appreciation is expressed to the scientific investigators and teachers who reviewed the draft copies; to the NASA specialists who provided diagrams and photographs; and to J. K. Holcomb, Headquarters Director of ASTP operations, and Chester M. Lee, ASTP Program Director at Headquarters, whose interest in this educational endeavor made this publication possible.

Teachers And Scientific Investigators Who Reviewed the Text

Harold L. Adair, Oak Ridge National Laboratory, Oak Ridge, Tenn.
Lynette Aey, Norwich Free Academy, Norwich, Conn.
J. Vernon Bailey, NASA Lyndon B. Johnson Space Center, Houston, Tex.
Stuart Bowyer, University of California at Berkeley, Berkeley, Calif.
Bill Wesley Brown, California State University at Chico, Chico, Calif.
Ronald J. Bruno, Creighton Preparatory School, Omaha, Nebr.
T. F. Budinger, University of California at Berkeley, Berkeley, Calif.
Robert F. Collins, Western States Chiropractic College, Portland, Oreg.
B. Sue Criswell, Baylor College of Medicine, Houston, Tex.
T. M. Donahue, University of Michigan, Ann Arbor, Mich.
David W. Eckert, Greater Latrobe Senior High School, Latrobe, Pa.
Lyle N. Edge, Blanco High School, Blanco, Tex.
Victor B. Eichler, Wichita State University, Wichita, Kans.
Farouk El-Baz, Smithsonian Institution, Washington, D.C.
D. Jerome Fisher, Emeritus, University of Chicago, Phoenix, Ariz.
R. T. Giuli, NASA Lyndon B. Johnson Space Center, Houston, Tex.
M. D. Grossi, Smithsonian Astrophysical Observatory, Cambridge, Mass.
Wendy Hindin, North Shore Hebrew Academy, Great Neck, N.Y.
Tim C. Ingoldsby, Westside High School, Omaha, Nebr.
Robert H. Johns, Academy of the New Church, Bryn Athyn, Pa.
D. J. Larson, Jr., Grumman Aerospace, Bethpage, N.Y.
M. D. Lind, Rockwell International Science Center, Thousand Oaks, Calif.
R. N. Little, University of Texas, Austin, Tex.
Sarah Manly, Wade Hampton High School, Greenville, S.C.
Katherine Mays, Bay City Independent School District, Bay City, Tex.
Jane M. Oppenheimer, Bryn Mawr College, Bryn Mawr, Pa.
T. J. Pepin, University of Wyoming, Laramie, Wyo.
H. W. Scheld, NASA Lyndon B. Johnson Space Center, Houston, Tex.
Seth Shulman, Naval Research Laboratory, Washington, D.C.
James W. Skehan, Boston College, Weston, Mass.
B. T. Slater, Jr., Texas Education Agency, Austin, Tex.
Robert S. Snyder, NASA George C. Marshall Space Flight Center, Huntsville, Ala.
Jacqueline D. Spears, Port Jefferson High School, Port Jefferson Station, N.Y.
Robert L. Stewart, Monticello High School, Monticello, N.Y.
Aletha Stone, Fulmore Junior High School, Austin, Tex.
G. R. Taylor, NASA Lyndon B. Johnson Space Center, Houston, Tex.
Jacob I. Trombka, NASA Robert H. Goddard Space Flight Center, Greenbelt, Md.
F. O. Vonbun, NASA Robert H. Goddard Space Flight Center, Greenbelt, Md.
Douglas Winkler, Wade Hampton High School, Greenville, S.C.

**Page
Intentionally
Left Blank**

Contents

Section 1	Introduction	1
<hr/>		
Section 2	High-Energy Radiation	3
	A. The Electromagnetic Spectrum and What Gets Through Our Atmosphere	3
	B. Photon Energy	4
	C. X-Rays, Gamma Rays, and Cosmic Rays	7
	D. X-Ray Telescopes—Collimators and Angular Resolution	8
	E. X-Ray Detectors	11
	F. Gamma-Ray Detectors	14
<hr/>		
Section 3	X-Ray and Gamma-Ray Sources in Space	17
	A. The Beginning of X-Ray Astronomy	17
	B. The NASA <i>Uhuru</i> X-Ray Satellite	20
	C. X-Ray Sources	21
	D. Explanations of Intrinsic X-Ray Power Output	25
	E. Questions for Discussion (Atmosphere, Planck Law, Energy)	31
<hr/>		
Section 4	X-Ray Spectra of Cosmic Sources	33
	A. Differences in Penetration of Hard and Soft X-Rays	33
	B. The Soft X-Ray Experiment, MA-048	34
	C. MA-048 Voltage Breakdown	38
	D. MA-048 Experiment Results—An X-Ray Pulsar	39
	E. Questions for Discussion (Interstellar Matter, Instrumental Calibration, Background, Black Holes, Doppler Effect)	42
<hr/>		
Section 5	Gamma-Ray Detectors and Nuclear Reactions in a Spacecraft	43
	A. Gamma-Ray Sources and Background	43
	B. Gamma-Ray Detectors	43
	C. The Crystal Activation Experiment, MA-151	44
<hr/>		
Section 6	Conclusions	49

Appendix A	Discussion Topics (Answers to Questions)	50
Appendix B	SI Units and Powers of 10	53
Appendix C	Glossary	56
Appendix D	Further Reading	61

Figures

Figure 2.1	The Spectrum of White Light	3
2.2	The Electromagnetic Spectrum and What Gets Through the Earth's Atmosphere	5
2.3	Schematic Diagram of a Dentist's X-Ray Machine	6
2.4	High-Energy Radiation Coming in on the Earth	8
2.5	How Optical Telescopes Form Images of Stars	9
2.6	X-Ray Collimator and its Angular Resolution	10
2.7	Ionization Chamber	12
2.8	Proportional Counter	13
2.9	Crystal Scintillator Gamma-Ray Detector With Anticoincidence Counter	15

Figure 3.1	Diagram of Aerobee Rocket Flight	18
3.2	Photograph of the Crab Nebula	19
3.3	Location of an X-Ray Source in the Sky by <i>Uhuru</i>	20
3.4	Celestial Coordinates	22
3.5	Map of the X-Ray Sources Located by <i>Uhuru</i>	23
3.6	Top View and Cross Section of the Milky Way Galaxy	24
3.7	Impacts of Infalling Electrons on Stars	28
3.8	Synchrotron Radiation From Free Electrons Moving in a Magnetic Field	29
3.9	The Compton Effect	30
3.10	The Inverse Compton Effect	30

Figure 4.1	The MA-048 Soft X-Ray Detector	34
4.2	Operation of the MA-048 Soft X-Ray Proportional Counter	36
4.3	Simplified Block Diagram of MA-048 Detector Electronics System	37
4.4	Spectrum of Cygnus X-2 Observed by the MA-048 Experiment	38
4.5	MA-048 Soft X-Ray Count Rates as a Function of Time	40
4.6	Explanation of the SMC X-1 X-Ray Pulsar	41

Figure 5.1	Diagram of the Sodium Iodide Crystal and Cell for the MA-151 Experiment	45
5.2	Diagram of MA-151 Container Holding the Germanium Crystal and Metals	46
5.3	Graph of Postflight MA-151 Counts in the Sodium Iodide Crystal Compared With Apollo 17 Postflight Counts	47
5.4	Graph of Postflight Counts in the Germanium Crystal	48

1 Introduction

After 4 years of preparation by the U.S. National Aeronautics and Space Administration (NASA) and the U.S.S.R. Academy of Sciences, the Apollo and Soyuz spacecraft were launched on July 15, 1975. Two days later, at 16:09 Greenwich mean time on July 17, the two spacecraft were docked. Then the astronauts and cosmonauts met for the first international handshake in space, and each crew entertained the other crew (one at a time) at a meal of typical American or Russian food. These activities and the physics of reaction motors, orbits around the Earth, and weightlessness (zero-g) are described more fully in Pamphlet I, "The Spacecraft, Their Orbits, and Docking" (EP-133).

Thirty-four experiments were performed while Apollo and Soyuz were in orbit: 23 by astronauts, 6 by cosmonauts, and 5 jointly. These experiments in space were selected from 161 proposals from scientists in nine different countries. They are listed by number in Pamphlet I, and groups of two or more are described in detail in Pamphlets II through IX (EP-134 through EP-141, respectively). Each experiment was directed by a Principal Investigator, assisted by several Co-Investigators, and the detailed scientific results have been published by NASA in two reports: The Apollo-Soyuz Test Project Preliminary Science Report (NASA TM X-58173) and the Apollo-Soyuz Test Project Summary Science Report (NASA SP-412). The simplified accounts given in these pamphlets have been reviewed by the Principal Investigators or one of the Co-Investigators.

The x-ray and gamma-ray experiments described in this pamphlet are of considerable interest because they represent the new field of high-energy astrophysics that came into being when instruments could be carried above the Earth's atmosphere by rockets. These instruments have detected x-rays and gamma rays coming from objects and regions of space that were not even suspected of being x-ray sources in 1960. The measurements show superhot stars, collapsed stars, Black Holes, and magnetic fields between the stars. A whole new view of the universe has been opened in x-ray and gamma-ray astronomy.

The Soft X-Ray Experiment, MA-048, was designed to locate and study the sources of x-rays coming toward Earth from deep space. Under the direction of Herbert Friedman at the Naval Research Laboratory (NRL) in Washington, D.C., a group of seven scientists, headed by Seth Shulman, built the equipment and analyzed the data. For background in understanding x-ray telescopes and their "count rates," Sections 2 and 3 outline the operation of x-ray detectors and show how x-ray data have led astronomers to the concept of "collapsed" stars—very high density Neutron Stars and Black Holes that curve space back into itself so that no particles or radiation can get in or out.

The Crystal Activation Experiment, MA-151, made no measurements of stars but tested the detectors used in measuring gamma rays outside the Earth's atmosphere. The detectors were tested before and after the Apollo-Soyuz flight at four major laboratories: the Lawrence Berkeley Laboratory in California, the Los Alamos Scientific Laboratory in New Mexico, the Oak Ridge National Laboratory in Tennessee, and the NASA Robert H. Goddard Space Flight Center (GSFC) in Maryland. These tests were coordinated by J. I. Trombka of GSFC. The differences between preflight and postflight test results show how cosmic rays, other high-speed protons, and neutrons changed the detectors during 217 hours in orbit.

Both x-rays and gamma rays are high-energy radiation and come from regions of space where the conditions are extreme (low density, high temperature, and high-speed particles). Cosmic rays are high-speed particles, *not* electromagnetic waves. The nature and behavior of both high-speed particles and high-energy photons are described in the next section.

2 High-Energy Radiation

A The Electromagnetic Spectrum and What Gets Through Our Atmosphere

Light carries energy in the form of waves. Visible light can be spread out by a prism or a diffraction grating into a spectrum from short violet waves to long red waves (Fig. 2.1). During the last century or two, physicists have learned how to measure invisible ultraviolet (UV) waves, which are shorter than violet, and invisible infrared (IR) waves, which are longer than red. Later they discovered even shorter x-rays¹ and even longer radio waves. These waves are generated by oscillations (back-and-forth motions) of electric charges—fast oscillations for the short waves and slow oscillations for the long waves. Although they are like water waves, light waves are not waves in any material. They are waves of electric and magnetic fields. Altogether, these waves make up the electromagnetic spectrum (Fig. 2.2), ranging from very short gamma rays through visible light waves with a wavelength of about 5000 angstroms (500 nanometers) to radio waves several kilometers in length.

Any hot body, such as the Sun or a star, “broadcasts” all these waves, which move at the velocity of light, 3×10^8 m/sec (186 000 miles/sec). A hot star gives out mostly short ultraviolet waves, a cool star mostly longer red waves, and the Sun (at intermediate temperature) mostly visible light—a good

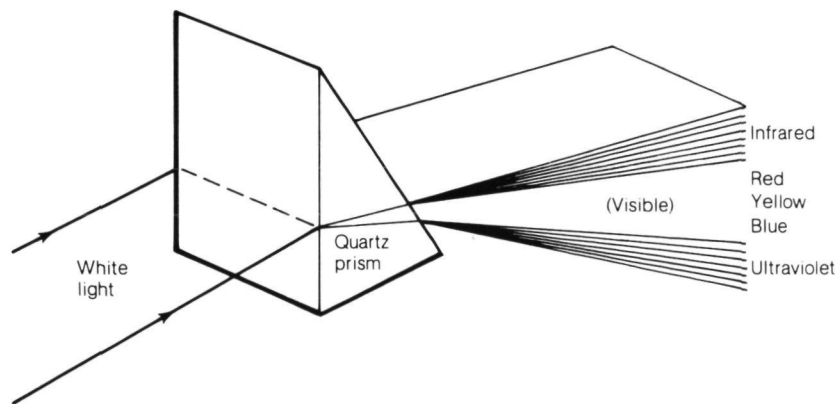

The spectrum of white light. Figure 2.1

¹Project Physics, Sec. 18.6; PSSC, Sec. 23-9. (Throughout this pamphlet, references will be given to key topics covered in two standard textbooks: “Project Physics,” second edition, Holt, Rinehart and Winston, 1975, and “Physical Science Study Committee,” (PSSC), fourth edition, D. C. Heath, 1976.)

reason why human eyes evolved to be sensitive to wavelengths near 5000 angstroms. Luckily, the ozone layer of the Earth's atmosphere blocks gamma rays, x-rays, and most of the ultraviolet waves. (These high-energy rays destroy living cells by ionizing molecules inside the cell.) Most of the infrared waves are absorbed by water, carbon dioxide, and other molecules in the atmosphere. Some radio waves are blocked by ions near the top of the atmosphere.

The transparency of the atmosphere for the electromagnetic spectrum is shown at the top of Figure 2.2. The scale of wavelength is given in both angstroms and meters (1 angstrom = 0.1 nanometer). The number of oscillations per second is called the frequency and is measured in hertz. The scale for frequency goes the opposite direction from the scale for wavelength: the long radio waves have low frequencies (3×10^3 hertz) and the short x-rays have high frequencies (3×10^{18} hertz). Note that frequency f multiplied by wavelength λ is equal to velocity v , or (3×10^{18} hertz) (1 angstrom) = 3×10^{18} Å/sec or 3×10^8 m/sec (186 000 miles/sec), which is the velocity of light.

B Photon Energy

About a century ago, it was shown that light also has particle characteristics. Light waves come in packets called quanta or photons, which cannot be subdivided. The quantum theory shows that the energy E of an indivisible quantum or photon is proportional to the frequency; that is, $E = hf$, where h is the Planck constant. The short-wavelength, high-frequency gamma rays and x-rays thus are high-energy photons.

X-rays are generated on Earth in the laboratory, the dentist's office, or the hospital by using a high voltage to shoot electrons at a target in a vacuum tube (Fig. 2.3). The higher the voltage, the faster the speed of the electron and the larger its kinetic energy on impact. This energy is measured in units called electronvolts. If the potential on the x-ray tube is 10 000 volts, the electron has a kinetic energy of 10 000 electronvolts, or 10 kiloelectronvolts. When such an electron hits the target, its energy is converted into an x-ray photon with an energy E of 10 kiloelectronvolts.

For this reason, x-rays and gamma rays are usually described (as on the lowest scale in Fig. 2.2) by their photon energy instead of by the wavelength λ or frequency f . The relation between E (in electronvolts) and λ (in angstroms) is easy to remember: $E = 12\,345/\lambda$. Therefore, x-rays with a wavelength of 1 angstrom are photons with energy of 12 345 electronvolts, or 12.3 kiloelectronvolts. Visible-light photons ($\lambda = 5000$ angstroms) have much lower energy: $E = 12\,345/5000 = 2.47$ electronvolts. In general, for electromagnetic radiation, $f = c/\lambda$, where c is the velocity of electromagnetic waves, 3×10^8 m/sec.

The electromagnetic spectrum and what gets through the Earth's atmosphere. Figure 2.2

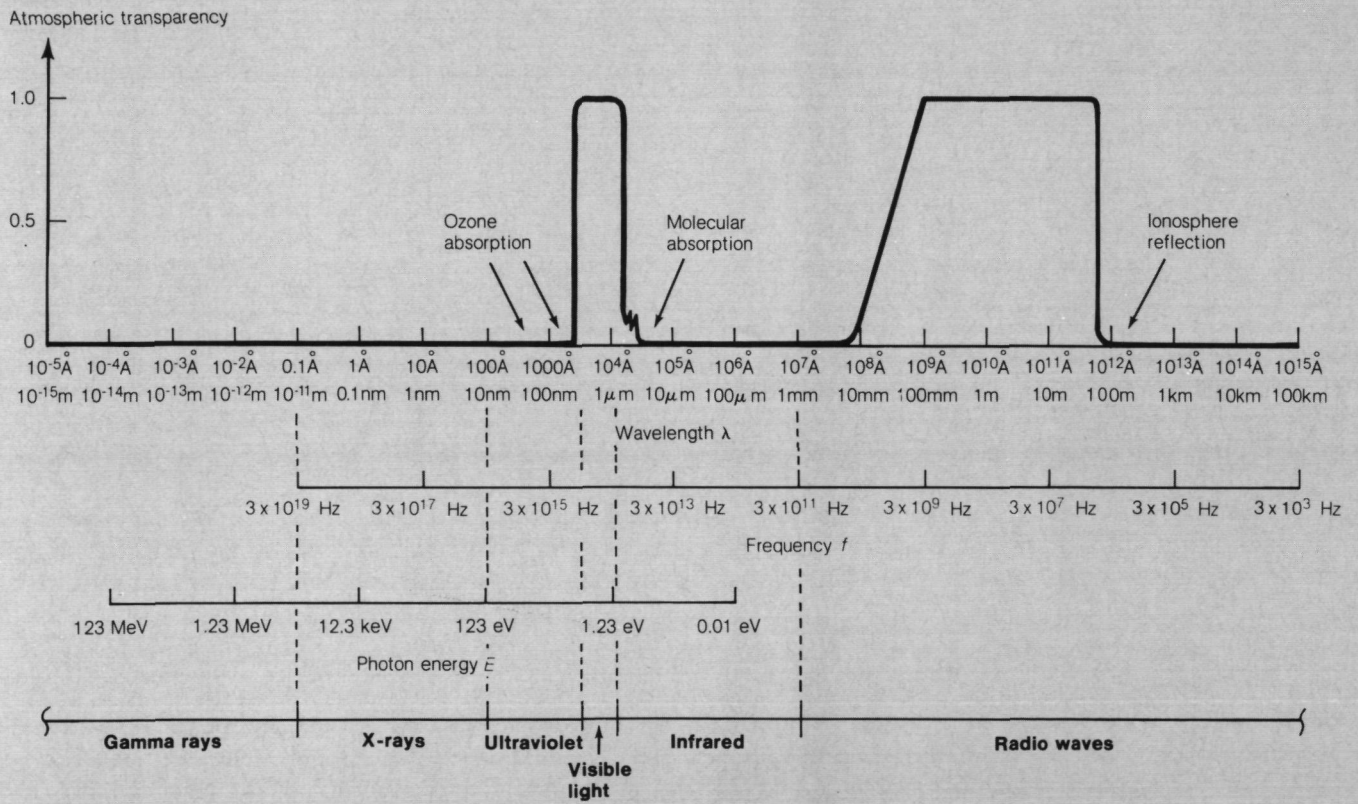
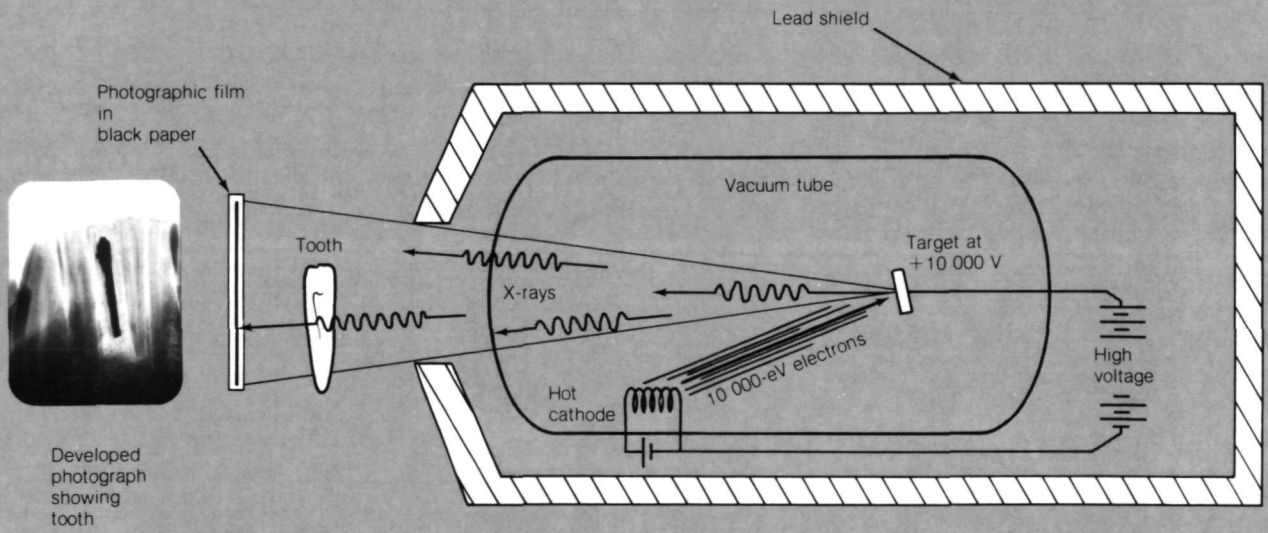

Figure 2.3 Schematic diagram of a dentist's x-ray machine. (Modern dentists use x-ray machines operated at 35 000 volts instead of the 10 000 volts shown here.)



C X-Rays, Gamma Rays, and Cosmic Rays

Manmade x-rays are used in dentists' offices and in hospitals to penetrate low-density material and make "shadow photographs" of higher density teeth and bones. The higher the x-ray energy, the more penetrating they are. You can't focus x-rays with ordinary lenses or mirrors like you can visible light; most of the x-rays are absorbed or go straight through. Dense materials like lead (in sufficient thickness) stop even the high-energy ("hard") x-rays and thus are used as shields to protect dental assistants and others who work with x-ray machines every day. (The ionization in cells where x-ray photons are absorbed damages human tissue if one person accumulates a large dose by repeated exposure.) Thin layers of lower density materials stop the low-energy ("soft") x-rays but let most of the hard x-rays through. This is the basis for x-ray filters that allow the measurement of soft and hard components in a beam of x-rays from a cosmic source like the Sun and its corona (see Pamphlet III).

Another form of "radiation" in space is the cosmic ray, which is actually a high-speed *particle* (atomic nucleus), not an electromagnetic wave. Fifty years ago, cosmic rays were thought to be waves. Then it was discovered that the high-speed (high-energy) particles produced gamma rays (photons) when they hit the Earth's upper atmosphere, as shown in Figure 2.4. Some of the particles and gamma rays get through, but most of them are stopped by the atmospheric shield, which also stops x-rays and most of the ultraviolet waves—as shown in Figure 2.2. In spacecraft above the atmosphere, there is no shield except that provided by the spacecraft walls or by filters in the experiment equipment. Space scientists wishing to measure x-rays or gamma rays must distinguish between gamma rays and high-energy cosmic-ray particles that behave very much like gamma rays. This distinction is usually made by using an anticoincidence counter that automatically subtracts the particle counts from all the counts recorded, leaving only the x-ray or gamma-ray counts. A "count" is recorded when one photon or particle passes through the detector. The intensity is the number of counts per second.

Cosmic rays come in toward the Earth from the nearby Sun (solar cosmic rays). Other rays of higher energy come more or less uniformly from all directions and are thought to originate in space between the stars in the Milky Way Galaxy (galactic cosmic rays). These solar and galactic cosmic rays (Fig. 2.4) pose a hazard to crewmembers on long space missions above the atmosphere. Some protection is provided by the pressure hull of the spacecraft cabin.

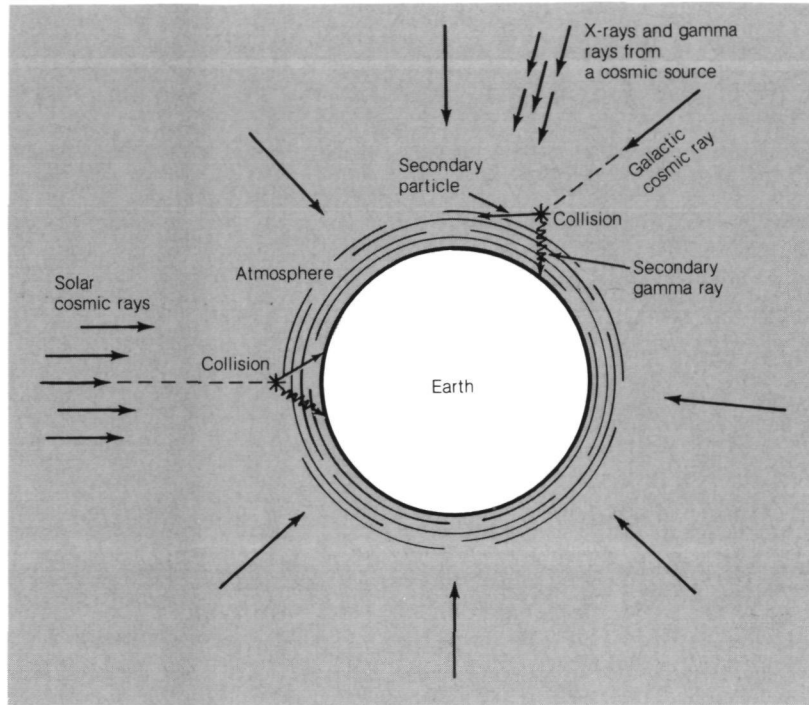

Figure 2.4 High-energy radiation coming in on the Earth.

D X-Ray Telescopes—Collimators and Angular Resolution

If an x-ray detector on a spacecraft counts x-ray photons, how can we tell from which direction they are coming? A telescope forms images of stars in visible light; the central image is the star toward which the telescope is pointed (Fig. 2.5). In general, x-rays cannot be imaged this way, so the x-ray astronomer must build a tube of lead or other x-ray-absorbing material to limit the field of view of his detector. If he uses a tube of small diameter, so as to define the direction accurately, very few counts will be recorded because the area of the tube will let only a few x-rays in. Therefore, he packs a number of tubes side by side in front of a detector (Fig. 2.6). These tubes all point in the same direction, thus forming a “honeycomb” or “eggcrate” having an area of several square centimeters. (You can get an idea of this arrangement by

How optical telescopes form images of stars. (X-rays go on through, forming no image.)

Figure 2.5

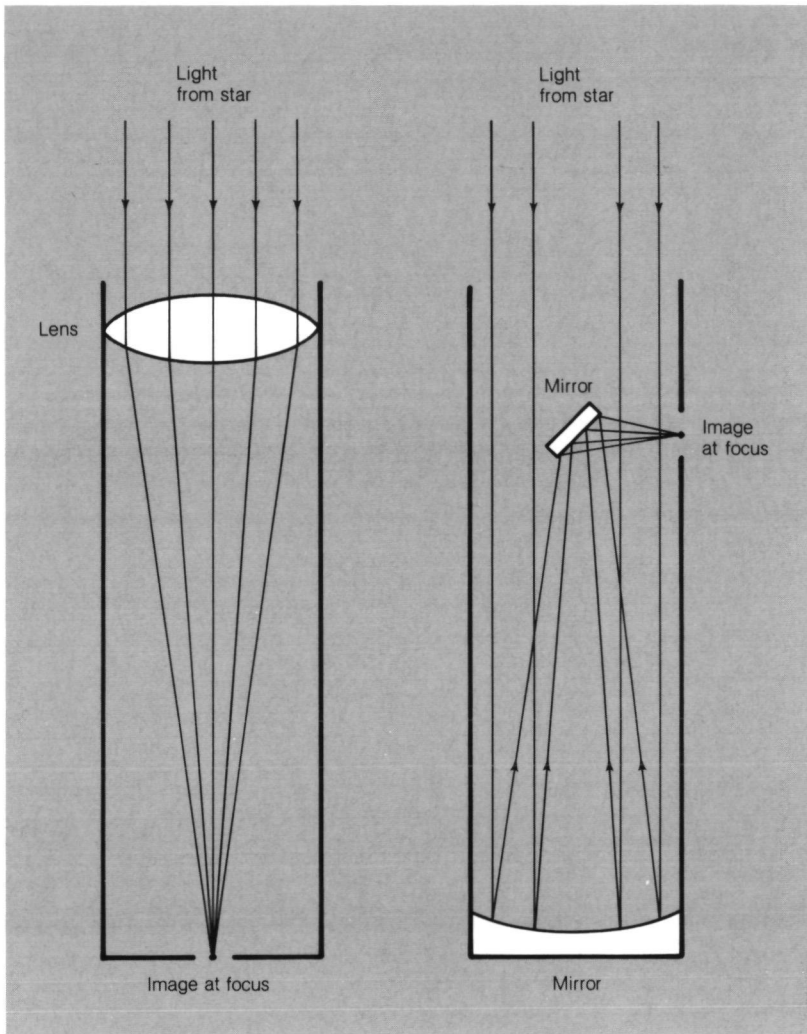

(a) Refractor (lens) telescope.

(b) Reflector (mirror) telescope.

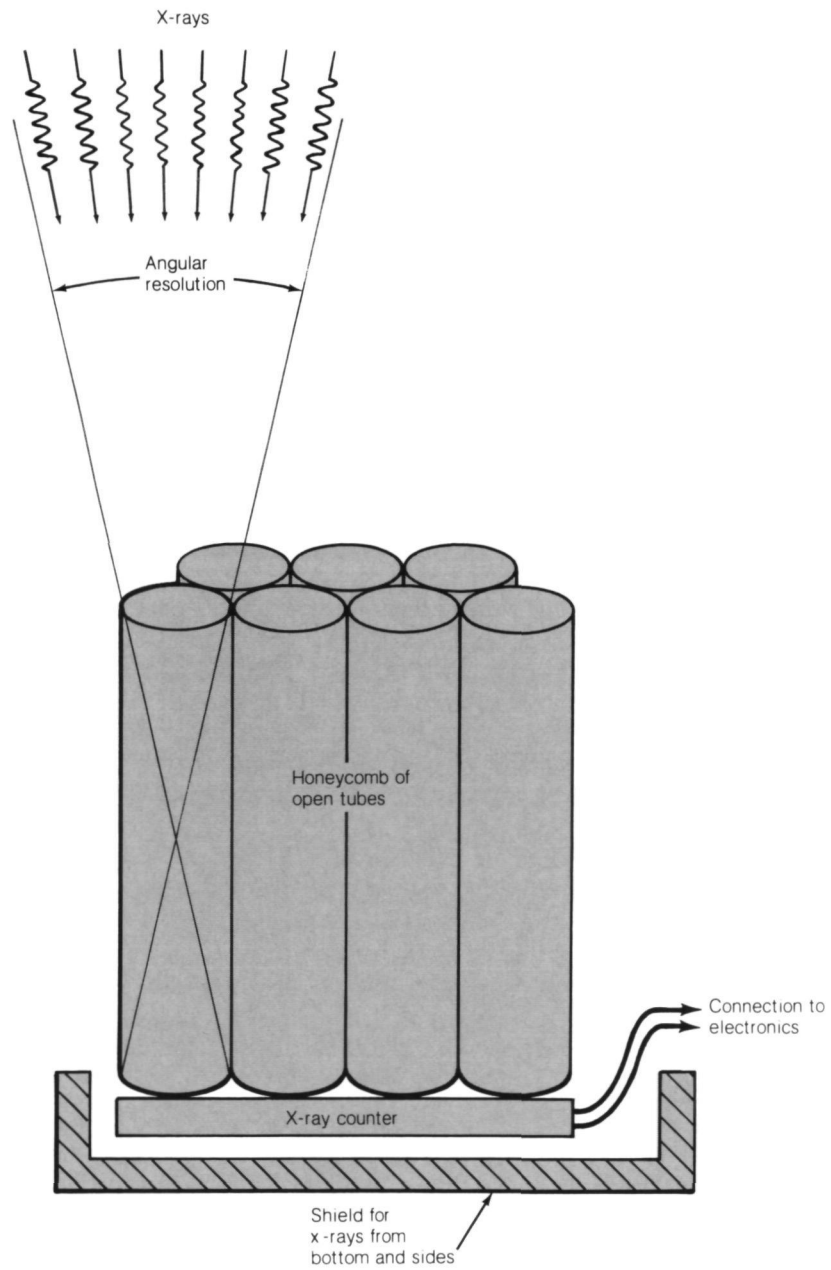

Figure 2.6 X-ray collimator and its angular resolution.

looking at a distant light through a handful of soda straws.) Such “collimators” accept x-rays from a circle of about 5° in the sky, and it is therefore impossible to distinguish between two x-ray sources less than 5° apart. In this case, the “angular resolution” is 5° .

There are several ways to narrow down the area in the sky where an x-ray source may be. One method is to sweep the x-ray telescope across the source (up and down, right and left) several times and note where the counts cease at the edges of the 5° collimator field. In this way, the location of an x-ray source in the sky can be limited to an “error box” of a few arc-minutes on each side, and the x-ray source can be identified with some known visible star, nebula, or galaxy in that box.

E X-Ray Detectors

The simplest x-ray detector is photographic film as used in the dentist’s office or in a hospital; however, film doesn’t work well in a sweep across an x-ray source. It is also difficult to convert the blackening of the developed film to the number of x-ray photons that passed through it. Therefore, x-ray astronomers have constructed several types of x-ray and gamma-ray detectors that are quantitative and more sensitive. The earliest detector was an ionization chamber—a gas-filled tube with metal electrodes charged to a few volts’ potential difference (Fig. 2.7). When x-rays pass through the tube, they ionize some of the gas by knocking electrons out of the atoms. The gas then conducts a small current between the electrodes that is proportional to the intensity (the number of x-ray photons passing through the tube each second).

Later modifications of the ionization chamber greatly improved its sensitivity by increasing the voltage between the electrodes and reducing the gas pressure. These new detectors (Geiger counters) simply counted each x-ray photon passing through by amplifying each pulse of electric current.

The latest detector, the proportional counter shown in Figure 2.8, is filled with gases such as argon and methane at about atmospheric pressure. When an x-ray passes through, it ionizes the gas, and the high voltage (approximately 2000 volts) causes the ions and electrons to “cascade” toward the electrodes, producing more ions and electrons on the way. When these ions and electrons hit the electrodes, they produce a pulse of current that is proportional to the original number of ions formed by the x-ray. Higher energy x-rays form more ions in the tube and thereby produce larger pulses. The electronic circuit sorts the pulses and stores them in “bins” (different sections of the electronic memory) according to pulse size. Because the pulse size is proportional to the x-ray energy, the first bin gets the count of x-ray photons with energy between 120 and 140 electronvolts (low energy, small pulses). The second bin gets the

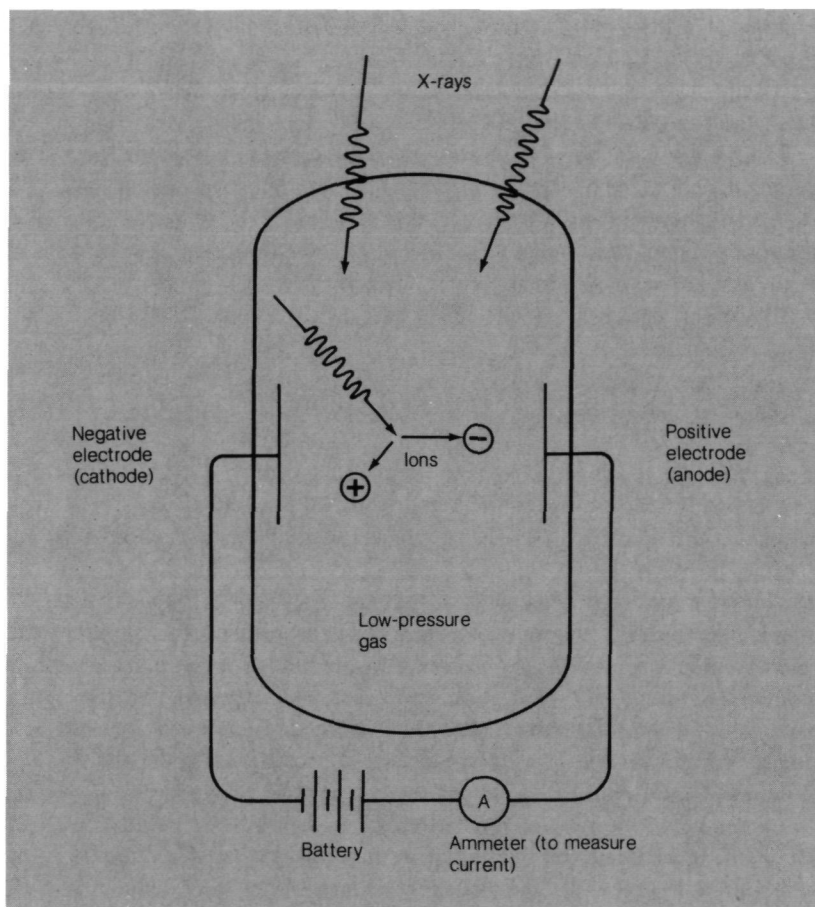
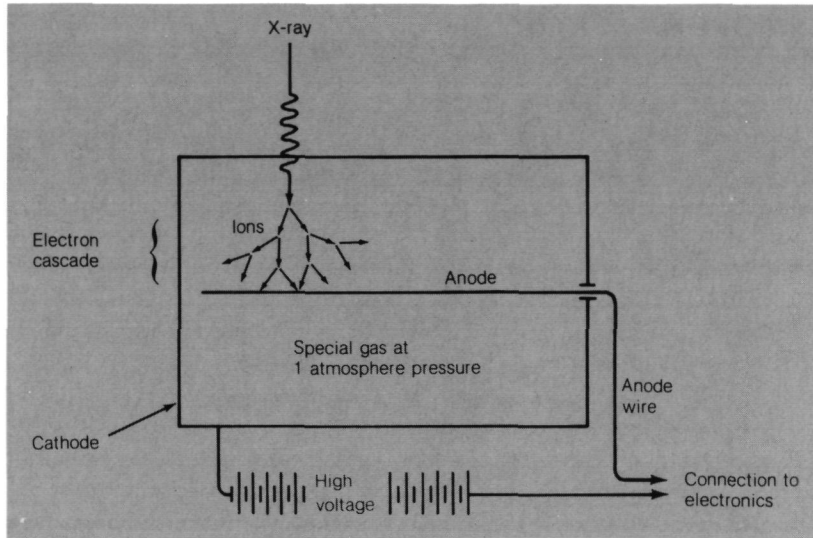

Figure 2.7 Ionization chamber. The current reading at **A** measures the number of x-rays crossing the tube per second from all directions.

count of 140- to 160-electronvolt photons; the third bin, 160- to 240-electronvolt photons; and so on up to bin 128, which gets the count of 9.5- to 10.5-kiloelectronvolt photons (high energy, large pulses). Thus, the proportional counter measures the *x-ray spectrum*—the number of photons in each energy range or in each group of wavelengths.



Proportional counter. An x-ray photon ionizes a gas atom, releasing one or more electrons that are accelerated toward the high-potential anode, ionizing more atoms and releasing more electrons—most of them close to the anode. The large electric pulse of this cascade is proportional to the number of ions formed by the x-ray and therefore to the energy of the x-ray photon.

Figure 2.8

Investigators can, of course, choose the number of bins to be used and the pulse sizes to be stored in each bin. On a space mission like Apollo-Soyuz, they can also select the interval of time the x-rays are counted before the bins are emptied by radioing the total count to Earth (the NASA Lyndon B. Johnson Space Center (JSC) in Houston). To detect short-term changes in x-ray intensity and to keep the bin size (number of counts) reasonably small, investigators make this counting-time interval small. The Apollo-Soyuz investigators used a counting interval of 3 milliseconds.

This 3-millisecond interval shows how fast the proportional counter is. Each electron pulse lasts about 1 microsecond. Even in a high-intensity x-ray beam, the chance of two photons arriving within 1 microsecond is extremely small. (The two would then be counted as one.) Statistical corrections can be made later if the count rate ever gets that high.

For lower energy photons (ultraviolet photons of energy from 4 to 200 electronvolts), a channeltron can be used as a detector.

F Gamma-Ray Detectors

For higher energy photons (gamma rays), crystal scintillators are used as detectors. In some transparent crystals, such as sodium iodide (NaI), gamma rays produce flashes of light ("scintillations") as they are absorbed. Each gamma ray is converted into an electron-positron pair. The light flashes are converted to electric pulses by a photomultiplier (a sensitive light detector) looking into the crystal, and the pulses are counted. The only problem is that cosmic-ray particles also produce scintillations in the crystal, so an anticoincidence detector must surround the crystal, as shown in Figure 2.9, and subtract the particle counts. Fortunately, a transparent plastic, such as lucite, flashes when a high-energy particle passes through but ignores gamma rays. Therefore, flashes in the plastic that coincide with flashes in the crystal can be canceled in the anticoincidence detector.

A honeycomb or eggcrate collimator doesn't work well as a gamma-ray telescope because the honeycomb material emits secondary gamma rays when it absorbs an incoming one. The detector would thus count more gamma rays than were actually received. One way to define the gamma-ray direction is to use the electron-positron pair created by the gamma-ray absorption. This pair, with kinetic energy equal to the energy of the gamma ray, continues in the same direction (a result of the conservation of momentum) and can be detected farther down the telescope axis by another particle detector (the Cerenkov detector in Fig. 2.9). As you can see, these high-energy-photon detectors must be complex in order to "sort out" photons of various energies coming from one direction and to avoid cosmic rays coming from all directions.

It should be noted that cosmic-ray particles are also recorded by "tracks" in the glassy particles of the lunar soil. When etched with hydrofluoric acid, these soil particles show microscopic lines caused by cosmic-ray particles that penetrated them: the deeper the penetration, the longer the track and the higher the cosmic-ray energy. Geophysicists count the number of tracks per square millimeter in many different particles that have been exposed on the lunar surface. They can estimate when these soil particles were exposed by noting the depth at which the soil was collected by the astronauts. In this way, the lunar soil, which has recorded cosmic-ray intensity during the last few billion years, is used by geophysicists as a cosmic-ray detector.

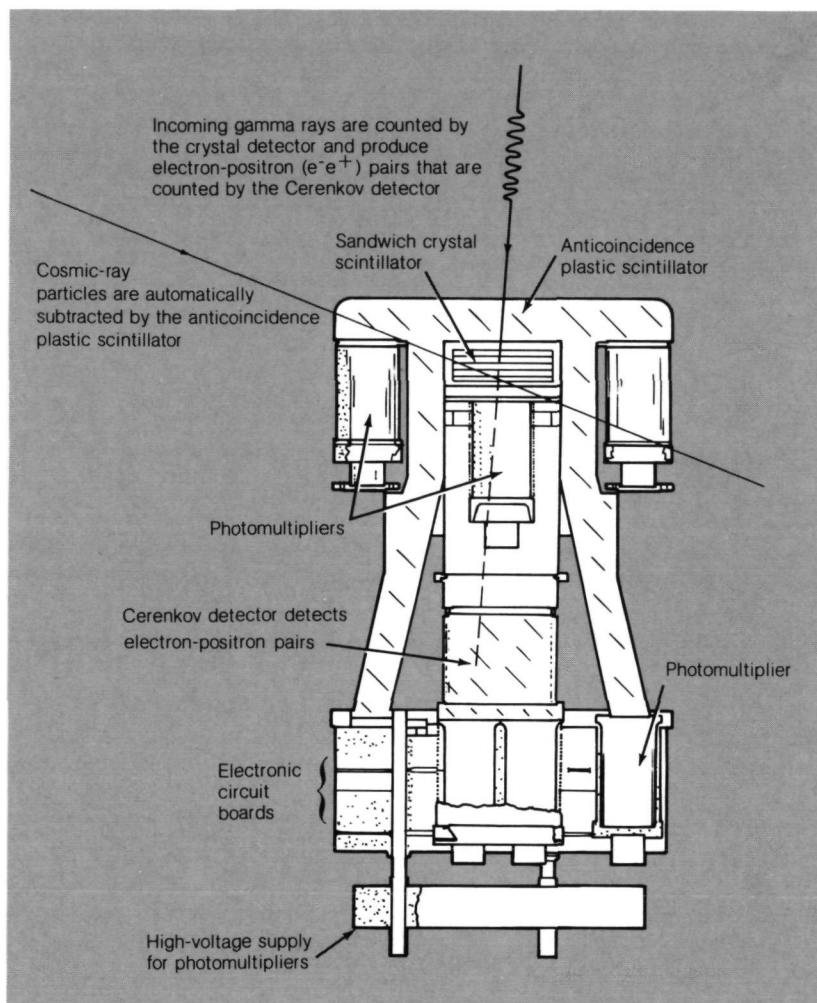

Crystal scintillator gamma-ray detector with anticoincidence counter Figure 2.9
 (schematic diagram of one carried on the Explorer 11 spacecraft).

3 X-Ray and Gamma-Ray Sources in Space

PRECEDING PAGE BLANK NOT FILMED

A The Beginning of X-Ray Astronomy

Although cosmic rays were well known in the 1950's, no astronomer expected to find x-ray sources in the sky. Because x-rays are blocked by the atmosphere (Fig. 2.2), x-ray telescopes had to be carried outside the atmosphere by sounding rockets. These rockets have been used since 1946 for far-ultraviolet observations of the Sun. As shown in Figure 3.1, NASA's small Aerobee rockets can be shot up 320 or 480 kilometers (200 or 300 miles) for a few minutes of observations, and the instruments can be recovered when they fall back to Earth. Instead of pointing the rocket in a preplanned direction, the founders of x-ray astronomy, Herbert Friedman of the NRL in Washington, D.C., and Riccardo Giacconi of the American Science and Engineering Company (AS&E) in Cambridge, Massachusetts, arranged to spin the rocket and survey a large part of the sky by sweeps with an x-ray telescope pointed out the side of the rocket.

It was in this way that rocket flights in 1963 first discovered a strong x-ray source in the constellation Scorpius and another in Taurus. Astronomers named these new objects by the constellation name followed by "X-1." The designations "X-2," "X-3," and so on were used for x-ray sources later discovered in the same constellation. Each constellation covers an area of the sky about 10° or 20° on each side. Because of poor angular resolution, it was difficult to identify these x-ray sources with astronomical objects. Taurus X-1 was located accurately when it was occulted (eclipsed) by the Moon. An x-ray telescope on a rocket recorded the time when the Moon passed in front of the source by timing the x-ray cutoff. The Moon's location was accurately known, and Taurus X-1 had to be in a small strip of sky that was along the Moon's edge at that time. Taurus X-1 was thus identified with the Crab Nebula, and its size could be estimated from the time taken by the Moon to cover it.

The fantastic Crab Nebula (Fig. 3.2) is a glowing mass of gas known to be the remnant of a supernova explosion in A.D. 1054, when a very bright "new star" was seen by Chinese and Japanese astronomers. In the 900 years since then, the exploding gas has expanded to the 3-arc-minute nebula shown in Figure 3.2. This makes sense; the violence of such a giant star exploding could leave a source of high-energy x-rays that might last for centuries. The Sun was also found to be an x-ray source, the most intense in our sky because it is so close. However, if our Sun were at the distance of the next nearest star (4 light-years), it would be barely detectable as an x-ray source.

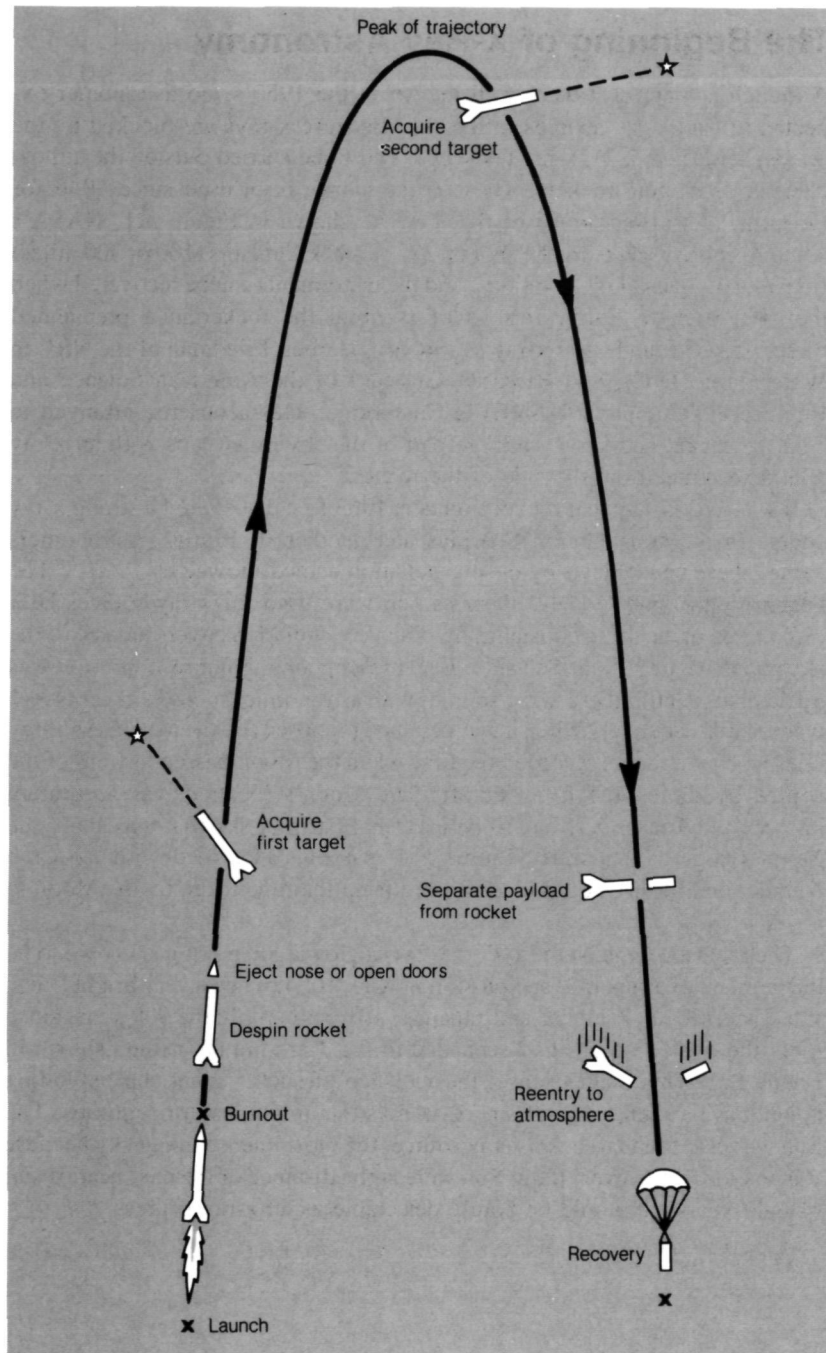

Figure 3.1 Diagram of an Aerobee rocket flight.

Photograph of the Crab Nebula. Figure 3.2

**ORIGINAL PAGE IS
OF POOR QUALITY**



B The NASA *Uhuru* X-Ray Satellite

During the 1960's, x-ray astronomers discovered a few dozen x-ray sources by using x-ray telescopes on rocket flights and on some unmanned satellites. Two of these x-ray sources were identified with supernova remnants and several with the Large Magellanic Cloud (LMC) outside our Milky Way Galaxy. Then, in 1970, the NASA Explorer 42 satellite, which was devoted entirely to x-ray astronomy, was launched from Kenya in eastern Africa. The launch day, December 12, 1970, was the seventh anniversary of Kenyan independence, so Explorer 42 was named *Uhuru*, which means "freedom" in Swahili. It carried two x-ray telescopes that were pointed out opposite sides and scanned the sky as the satellite rotated slowly (once every 12 minutes). The x-ray telescopes were built by Giacconi and his collaborators at AS&E. These men analyzed the x-ray counts (energy of 2 to 10 kiloelectronvolts) that were transmitted by radio to the ground receivers of the NASA Spacecraft Tracking and Data Network (STDN).

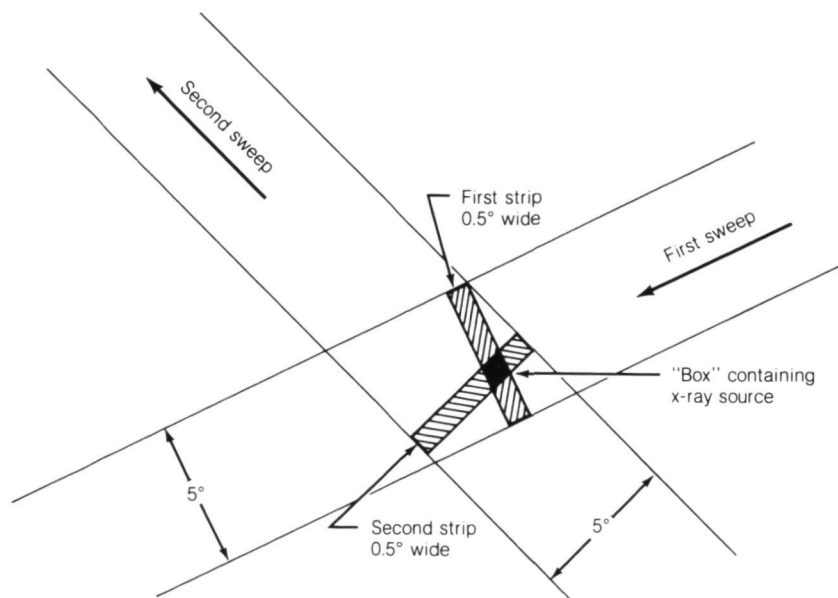

Figure 3.3 Location of an x-ray source in the sky by the *Uhuru* satellite. Two of *Uhuru*'s 5° sweeps gave maximum count rates for the heavily outlined strips. The x-ray source must be in the shaded "box" where the two strips cross.

Uhuru circled the Earth every 96 minutes in an orbit 540 kilometers (335 miles) above the Equator at an orbital inclination of 3° . Its spin axis slowly changed so that the x-ray telescope swept across each source from different directions (Fig. 3.3). The telescope collimators each had a fan-shaped beam 5° wide by 0.5° thick (along the sweep direction). As these fan-shaped beams swept across a source in the sky, the x-ray count rate increased to a maximum, then decreased. The *time* of the maximum count rate showed the 5° by 0.5° strip of sky where the source was. On a later sweep across the same source, another strip was plotted that crossed the first one. The x-ray source was located in the “box” where the two strips crossed. This technique can determine the location of an x-ray source to within a few arc-minutes.

C X-Ray Sources

Uhuru had located and measured almost 200 x-ray sources before its electronic circuits failed after 3 years of operation. Although the early source names (Scorpius X-1, etc.) are being retained, numerous new sources are known by their celestial coordinates,² right ascension (which is like longitude on Earth) and declination (like latitude)—see Figure 3.4. Thus, “3U 0930–40” designates a source in the Third (last) *Uhuru* Catalog at right ascension 09 hours and 30 minutes (on a scale increasing eastward from 0 to 24 hours) and declination -40° .

The 3U sources are plotted in Figure 3.5, a map of the sky where the usual right-ascension and declination coordinates have been replaced by galactic longitude and latitude. These coordinates are based on our position within the Milky Way Galaxy—a huge disk of more than 100 billion stars plus gas and dust (Fig. 3.6). Our Sun is located about two-thirds of the way from the center to the edge of the disk. From our position inside this disk, we see the familiar Milky Way band of stars around the sky, representing a view along the disk. The concentration of stars in the Milky Way is highest in the direction of the Galaxy center, toward the constellation Sagittarius. Galactic longitude is 0° at this point and increases eastward. (In Fig. 3.5, which is a map of the sphere of the sky as seen from the *inside*, east is to the left.) Galactic latitude begins at 0° along the Galactic Equator—the middle line of the Milky Way band seen in the sky.

It is clear that strong x-ray sources (shown by the large dots on Fig. 3.5) tend to be concentrated near the Milky Way, which indicates that they are probably objects in the disk of our Galaxy. However, two groups at the lower

²Project Physics, Secs. 5.1 to 5.3.

right (galactic longitudes 270° and 300° , latitudes 30° and 35° S) are identified with the Magellanic Clouds, two small galaxies definitely outside our Galaxy (extragalactic). The Magellanic Clouds are visible only from the Southern Hemisphere of the Earth; they are not visible from the United States.

Other sources near the Galactic North Pole (latitude 90° N) are probably extragalactic. The faint ones near the Galactic Equator may be extragalactic, or they may be objects in the Milky Way disk that are faint because of the large distance between them and the Earth.

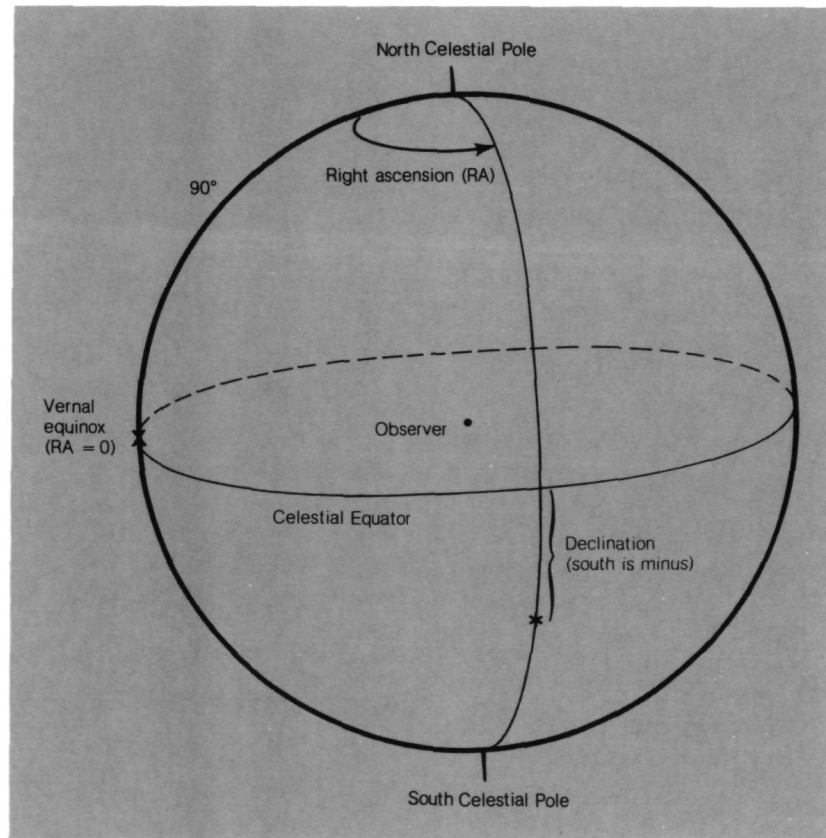
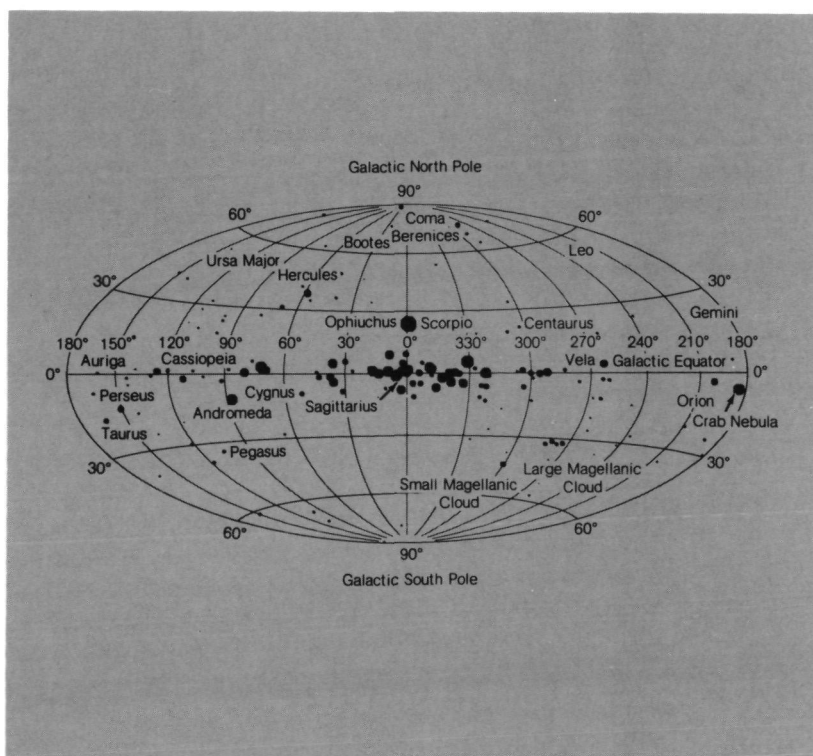

Figure 3.4 Celestial coordinates. The observer is looking outward from the center of an imaginary sphere. Each point in the sky (on the celestial sphere) has its own coordinates, right ascension and declination.

These x-rays have traveled enormous distances, as much as 200 000 light-years from the Magellanic Clouds and 100 000 light-years across our Galaxy. This fact brings us back to the penetrating power of x-rays. Some of the ordinary light from a star is absorbed by interstellar dust as it travels across the Milky Way disk. Even with the largest telescopes, optical astronomers cannot see as far as the center of our Galaxy. However, high-energy (hard) x-rays come through the dust as easily as through a piece of paper (which is about the equivalent of the dust in our line of sight across the 100 000-light-year galactic disk). The faint source in Sagittarius could be at the far edge of the disk—or even farther away in another galaxy.



A map of 2- to 10-kiloelectronvolt x-ray sources located in the sky by the *Uhuru* satellite. Constellation names indicate their approximate areas. Ursa Major is the “Big Dipper.” Sagittarius is in the direction of the center of our Milky Way Galaxy. The Magellanic Clouds are outside galaxies.

Figure 3.5

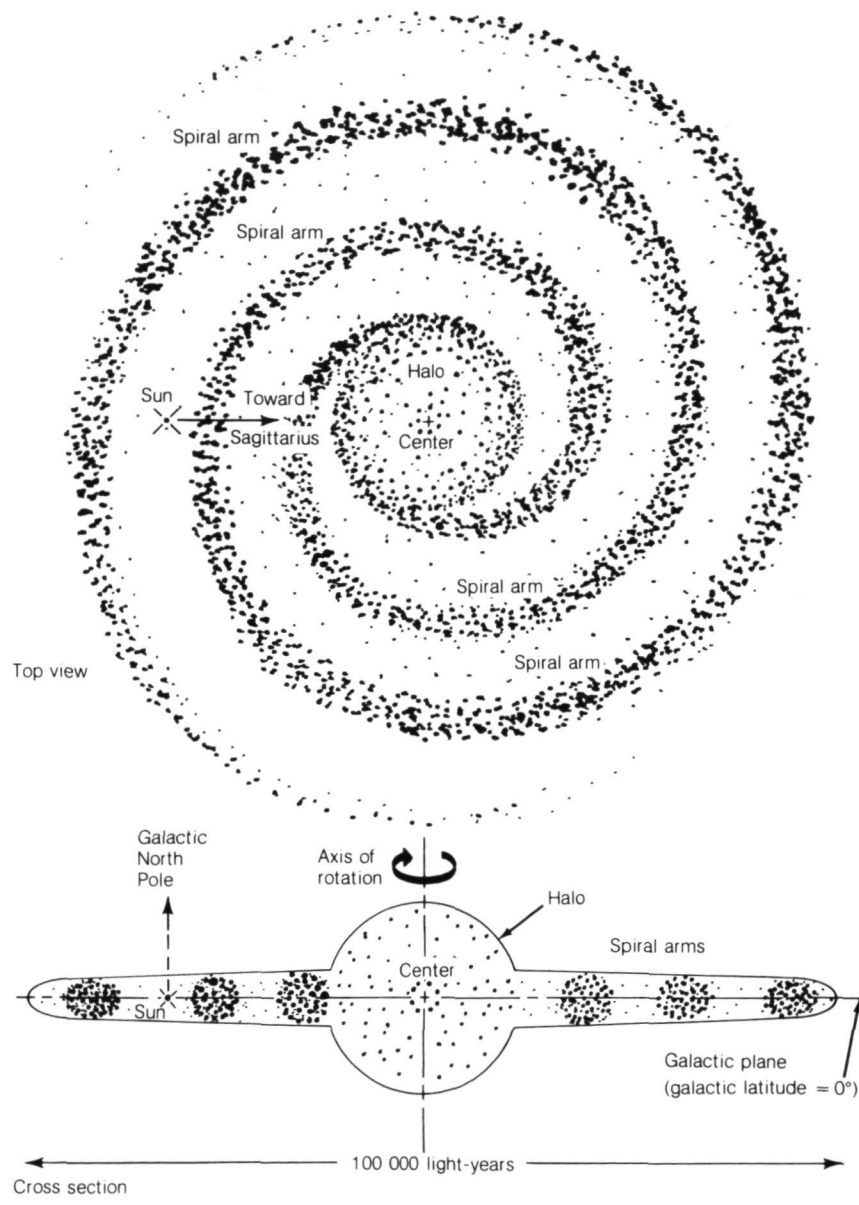

Figure 3.6 Top view and cross section of the Milky Way Galaxy, a gigantic rotating disk of stars, gas, and dust, about 100 000 light-years in diameter and 5000 light-years thick, with a bulge or halo around the center of mass.

You might think that the bright x-ray sources (large dots on Fig. 3.5) are the nearer ones, but the brightness that we observe depends on two factors: distance and intrinsic power. A bright x-ray source may be a distant one of very high intrinsic power; that is, high power output. The faint ones may be relatively nearby stars with very low intrinsic x-ray output. Identification of the x-ray sources with optical objects can help solve this problem. For instance, we know how far away the Crab Nebula is and, from the x-ray brightness, we can compute its intrinsic x-ray power output. This power output is probably similar to the intrinsic power of other supernova remnants. However, this does not help us to determine the intrinsic x-ray power of *x-ray stars* like Scorpius X-1, because they may generate x-rays in a completely different way.

D Explanations of Intrinsic X-Ray Power Output

Normal electromagnetic radiation from a very hot star cannot account for x-ray sources. Astronomers find many red and yellow stars with temperatures from 3000 to 6000 K, fewer stars from 7000 to 20 000 K, and very few stars as hot as 50 000 K. (One star with a temperature of 100 000 K was observed from Apollo-Soyuz; see Pamphlet III.) To radiate mostly x-rays, a star's surface would have to be 10 000 000 K or hotter. (The dominant wavelength in angstroms radiated by a "perfect black body" at temperature T is $\lambda_m = 28\,800\,000/T$.) The surface of such a superhot star would cool very rapidly, however, unless the star had an inexhaustible fuel supply. The total energy radiated per second is proportional to T^4 , and a sizable fraction of this energy appears in visible wavelengths. If x-ray sources were superhot stars, they would be visually bright and would probably disappear after a few months or a year, which is not the case.

Physicists have studied the generation of x-rays and suggest three possibilities for the sources in space: (1) bremsstrahlung, (2) synchrotron radiation, and (3) the inverse Compton effect.

1. *Bremsstrahlung*. Bremsstrahlung is a German word meaning "brake radiation" and is the source used in dentists' and doctors' x-ray machines. The "braking" occurs when a high-speed electron or ion strikes some other material and is decelerated, stopped, or bounced off in a new direction. The theory of electromagnetic waves predicts such radiation when an electric charge experiences a large acceleration (change in velocity). The only question is how the electrons or ions got their high velocity out in space in the first place.

There are several possibilities. We know that there are extreme conditions in the atmospheres of stars—high-speed particles (such as the solar wind coming from the Sun), electric fields, magnetic fields, and very high

temperatures—all of which affect the motions of electrons and ions. However, none of these conditions explain the acceleration of electrons to speeds high enough to produce x-ray bremsstrahlung of the energy measured in Scorpius X-1. Another possibility is gravitational force. If matter falls in toward a hot, massive star, it would be ionized into electrons and ions, which would then impact on the surface of the star.

Figure 3.7 shows the calculation of impact velocity (which is equal to the velocity of escape from the star's surface; see Pamphlet I) and the resulting photon energy in electronvolts (1 electronvolt = 1.60×10^{-19} joules). The infalling protons with a mass m_p of 1.7×10^{-27} kilograms have much higher kinetic energy than electrons with a mass m_e of 9.1×10^{-31} kilograms. (The kinetic energy of the electrons is 1840 times smaller.) The proton impacts therefore give the soft x-ray bremsstrahlung from an ordinary star. Each electron impact releases approximately 1 electronvolt of energy and produces infrared photons (see Sec. 2B). To get hard x-rays of energy 50 to 100 kiloelectronvolts (Fig. 2.2), proton impact velocities of 3000 to 4000 km/sec are required. Such velocities are possible only if the star is much more compact than the Sun (about one thirty-fifth of the Sun's radius), that is, having much higher density and much higher surface gravity.

Normal stars are about the same size as the Sun, approximately 10^6 kilometers in diameter and 2×10^{30} kilograms in mass. Giant stars are 100 times larger and 10 times more massive. All these stars are kept "puffed up" by the huge release of energy from nuclear reactions in their cores (see Pamphlet III). In these nuclear reactions, hydrogen is converted to helium under the extremely high pressure and high temperature in the core of a star. After most of the hydrogen is used, the nuclear-energy output decreases, and, generally after an explosion, the old star collapses. Its gas is no longer kept inflated by radiation pressure and hot gases. Gravitational force pulls the cooling gas into a White Dwarf. Other changes occur in the compressed gas, which becomes "degenerate"—that is, it no longer follows the normal gas laws. Gravitational force has less and less opposition and pulls the material of the star into such a compressed state that most of the atoms are broken into neutrons and jammed close together. The density becomes extremely high. White Dwarf stars are about 100 times smaller than the Sun. A Neutron Star should be less than 100 kilometers in diameter, or less than one-hundredth of the diameter of the Earth.

Newton's Law of Gravitation states that gravitational force $F_g = GmM/r^2$ (see Pamphlet I), where G is a constant, m and M are the masses attracting each other, and r is the distance between them. Because r^2 is in the denominator, F_g has very large values in a collapsed star. These huge forces further compress the material of the star and overwhelm nuclear forces. White Dwarfs and Neutron Stars are stable stages in this process of collapse, when the

material resists further compression for a time (perhaps 100 million years). When the density reaches values like 10^6 gm/cm³ in a White Dwarf, it changes the geometry of space, as stated in Einstein's Theory of General Relativity. If the star's mass M is large enough and its radius R gets small enough, space is curved so sharply around the collapsed star that light cannot get out. At this stage, the star, now less than 10 kilometers in diameter, becomes a "Black Hole." (The Earth would have to be squeezed to the size of a Ping-pong ball to become a Black Hole.) X-ray observations have recently given new evidence of Neutron Stars and Black Holes. White Dwarfs have been observed with optical telescopes for the past 50 years.

Figure 3.7 gives a simplified picture of electrons and protons falling into stars. The electrons and protons are accelerated to the velocity of escape v_e before they strike the surface of the star. Actually, there is gas above the visible surface of an ordinary star, like the corona above the Sun's surface (see Pamphlet III). So the electrons and protons seldom reach the full value of $v_e = 615$ km/sec. When the electrons strike gas atoms at speeds of 500 to 600 km/sec, their kinetic energy is equivalent to about 1 electronvolt. The protons have about 1840 times as much energy and give soft x-rays as bremsstrahlung. However, if the star is a Neutron Star with much smaller radius (R_N), the impact velocities are more than 80 times larger, and the proton bremsstrahlung comes off as gamma rays with 14 megaelectronvolts of energy. Even the electrons falling on a Neutron Star produce 7-kiloelectronvolt x-ray bremsstrahlung.

Where does the infalling matter come from? Astronomers guess that it comes from another star close by—a less compact companion in orbit around the compact star, as described in Section 4. This scientific sleuthing also finds other means of generating x-rays in space. (The good detective-scientist tries to fit all the available clues and then get more evidence to "prove his case in court.")

2. *Synchrotron radiation.* If there is little material on which to impact (that is, if there is no possibility of bremsstrahlung), high-speed electrons in nearly empty space can generate x-rays by spiraling in a magnetic field. This effect is well demonstrated in modern physics laboratories with a synchrotron, a machine in which groups of electrons or protons are guided around circular paths by a magnetic field. Their speed is increased by an alternating electric field pulsed to pull them around in their orbits. Such a machine produces light and x-rays because the electrons oscillate in spirals around the magnetic lines of force. The same situation could arise in space (Fig. 3.8).

Each oscillating electron emits synchrotron radiation—electromagnetic waves of frequency f that depend on the electron's speed v and the strength H of the magnetic field (f is proportional to Hv^2v^4). Even in a small magnetic field (much less than exists on Earth), an electron moving at very high speed

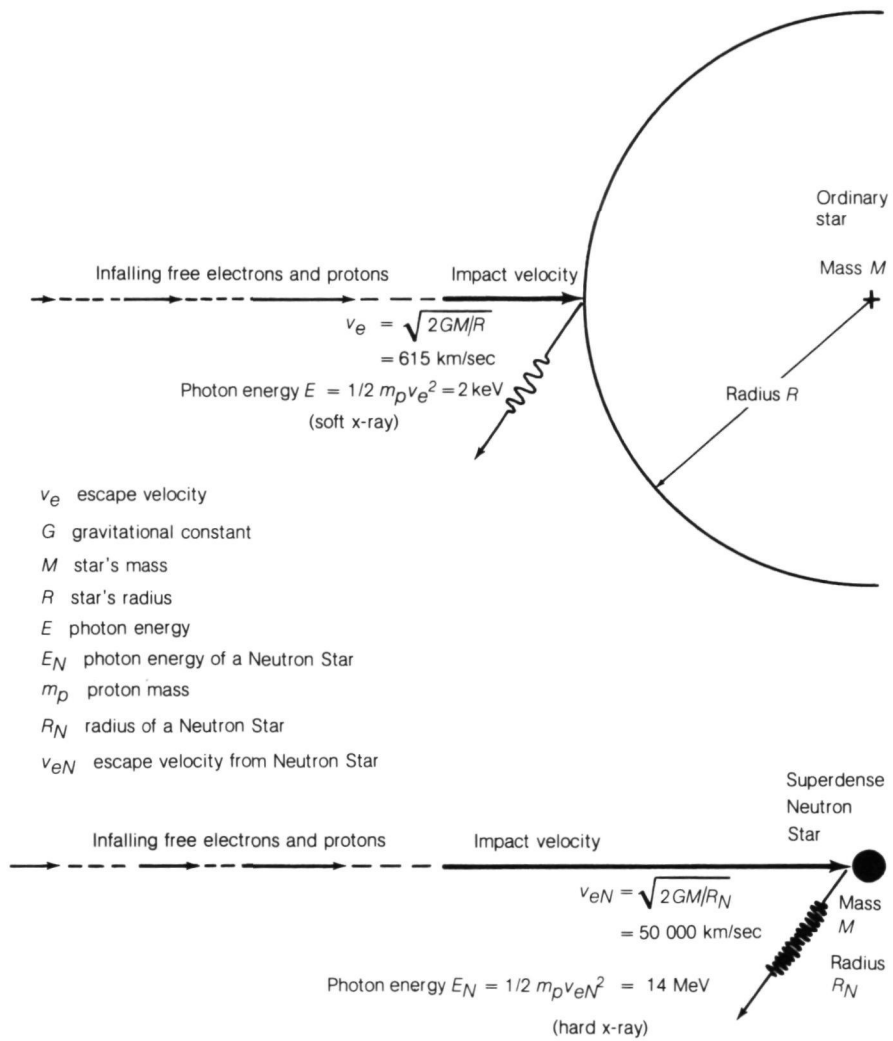
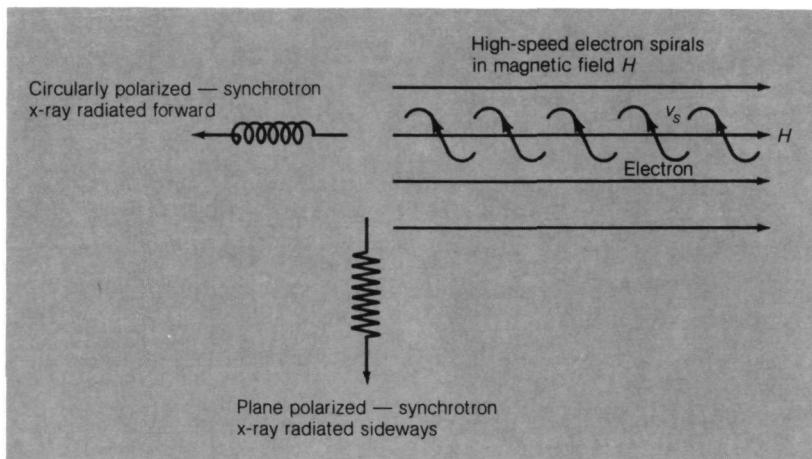

Figure 3.7 Impacts of infalling electrons on stars. Only very dense stars have enough gravitational potential to generate hard x-rays by impact (bremsstrahlung).

will radiate x-rays. Again, you may ask, where do the high-speed electrons come from? And what caused the magnetic field in space? Astronomers answer that the strong magnetic field inside a large star would be trapped in the “plasma” of ions and electrons and carried outward, although weakened,



Synchrotron radiation from free electrons moving in a magnetic field H . The field forces the electrons to “spiral” around lines of force. Figure 3.8

to great distances by a supernova explosion. The Crab Nebula (Fig. 3.2) may thus have a magnetic field throughout its large volume. Electrons might be shot into this magnetic field from nearby stars. In any case, cosmic rays are passing through it and emitting synchrotron radiation of higher energy than the electrons.

As seen from the side view (Fig. 3.8), synchrotron radiation should be plane polarized.³ (It is circularly polarized if viewed along the magnetic field.) Plane polarization was found in light and x-rays from the Crab Nebula (Fig. 3.2), which confirmed that synchrotron radiation is coming from that nebula. Synchrotron x-rays are to be expected from fairly large volumes such as nebulae, whereas bremsstrahlung x-rays are more likely from individual stars. In addition, there is good evidence of a small magnetic field throughout the disk of our Galaxy, and synchrotron radiation can occur wherever electrons or other charged particles are shot into it.

3. *Inverse Compton effect.* The inverse Compton effect is a third possible source of x-rays in space. The Compton effect⁴ (Fig. 3.9) was discovered in laboratory experiments by the American physicist Arthur Compton. He found that a photon passing an electron and an ion in low-density gas may throw out the electron (that is, increase the electron's energy from E_1 to E_2) by losing

³Project Physics, Sec. 13.7.

⁴Project Physics, Sec. 20.2; PSSC, Sec. 25-4.

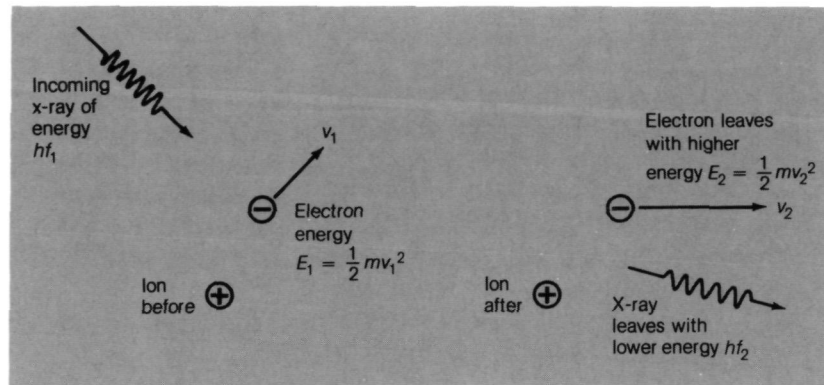

Figure 3.9 The Compton effect. In this interaction between an x-ray and an electron near a positive ion, energy and momentum are conserved.

some of its own energy (hf_1). That is, $E_2 - E_1 = hf_1 - hf_2$, where the reduced photon frequency f_2 is less than the original f_1 . Under certain conditions, the inverse occurs; for instance, when a photon overtakes an electron moving in the same direction. The energy and frequency of the photon are then increased and the energy of the electron is reduced (Fig. 3.10). After several such encounters, an ultraviolet photon can be “beefed up” to an x-ray photon by stealing the energy of electrons and ions.

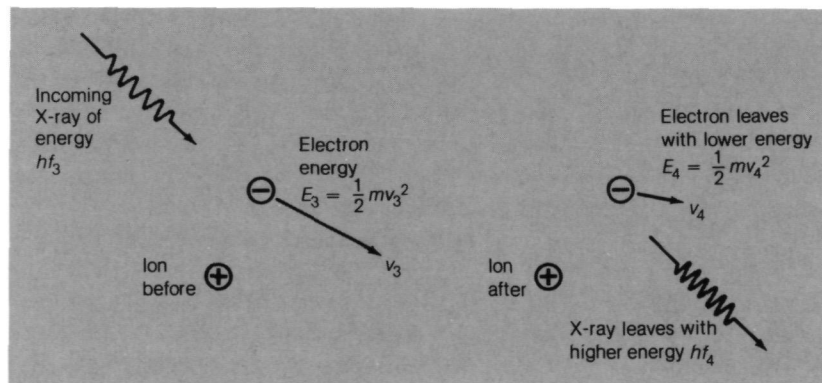

Figure 3.10 The inverse Compton effect. When the angle between an incoming photon and the electron velocity v_3 is correct, the electron loses energy to the photon.

E Questions for Discussion

(Atmosphere, Planck Law, Energy)

This new field of x-ray astronomy has raised several questions that need more thought and research. The following go beyond the content of this pamphlet but are interesting topics for discussion.

1. If the Earth's atmosphere were suddenly made transparent to all wavelengths of electromagnetic radiation (Fig. 2.2), what major changes would you expect on Earth? If it had always been this way, what further differences would be expected?
2. In a color television set, there is a transformer giving a potential of 20 000 volts for the scanning electron beam. Every 0.05 second, the beam scans the picture in 525 lines, each line consisting of 525 dots (picture elements or "pixels"). What bremsstrahlung would be expected from the television tube?
3. In Section 2A, the statement is made that hot bodies radiate all wavelengths in the electromagnetic spectrum. What about *zero* wavelength?
4. Cosmic rays come from all directions. Some are absorbed each second by the Earth, other planets, the Sun, and stars. Does this mean that cosmic rays are decreasing in intensity?
5. How can we measure or estimate the distance to an x-ray source?
6. What further measurements should be made on x-ray sources by a new high-energy satellite to replace *Uhuru*?
7. Where does the energy come from that is radiated in synchrotron x-rays?
8. If cosmic-ray electrons are passing through a magnetic field throughout the disk of our Galaxy, what would you expect to be added to the map of x-ray sources in the sky (Fig. 3.5)?

4 X-Ray Spectra of Cosmic Sources

A Differences in Penetration of Hard and Soft X-Rays

Because of the penetrating power of x-rays, we can “see” x-ray sources (Fig. 3.5) through the interstellar smog of our Milky Way Galaxy, but we have no easy way to estimate how far away these sources are. The optical astronomer can estimate distances of stars in the Milky Way by interstellar reddening and by the strength of interstellar absorption lines in their spectra. The reddening occurs because red light penetrates dust or smog better than blue light does. A fairly distant star is thus redder than it ought to be (as indicated by other features in its spectrum, such as the strengths of spectral lines) because most of its blue light has been absorbed by smog en route to the Earth. In the same manner, soft x-rays (0.1 to 1 kiloelectronvolt) are less penetrating than hard x-rays (2 to 20 kiloelectronvolts). Thus, we expect that measurements of a distant source would show less than “normal” soft x-rays, whereas a nearby source would have the “normal” ratio of soft-to-hard x-rays. (So far, an actual standard for “normal” has not been established.)

A partial survey of soft x-rays from sources in the Milky Way was made by F. D. Seward on two Aerobee rocket flights in 1972, and the results tend to confirm this distance effect. Soft x-ray intensity in the 0.3- to 0.5-kiloelectronvolt band was compared to the hard x-ray intensity (2 to 10 kiloelectronvolts) measured by *Uhuru*. Two sources stand out as being nearby: Vela X-1 and Cygnus X-1. Both are large nebulae (supernova remnants) several degrees across and about 3000 light-years from Earth. Another supernova remnant, Cassiopeia X-1 (Fig. 3.5), could not be detected in soft x-rays of energy 0.3 to 0.5 kiloelectronvolt, although it showed weakly in the 0.5 to 1-kiloelectronvolt range. It is estimated to be 10 000 light-years distant. However, other soft x-ray sources are *not* nebulae, and the ratio of their soft-to-hard x-ray strength is possibly different because of the way their x-rays are generated. Seward estimates that seven of these sources are about 40 000 light-years from us, near the center of the Galaxy, and that another 10 are about 15 000 light-years away.

Optical spectra can help specify what the “normal” color of a star should be, and hence the degree of a star’s reddening can be used to estimate its distance. However, further study of x-ray spectra is needed before distances can be estimated from their characteristics. Until that is done, reliable distances of x-ray sources come only from optical studies of the objects with which they are identified.

B The Soft X-Ray Experiment, MA-048

The MA-048 Experiment was a study of spectra in the range from 0.1 to 10 kiloelectronvolts and a survey of the soft x-ray background over a large fraction of the sky. Although the x-ray detector, a 30- by 75-centimeter (12- by 30-inch) proportional counter (Fig. 4.1), had periodic high-voltage breakdowns between the electrodes (at 2700 volts), it detected 12 x-ray sources, including Cygnus X-2, Hercules X-1, Vela X-1, SMC X-1 in the Small Magellanic Cloud, and the White Dwarf star called HZ 43 (number 43 in a list prepared by Milton Humason and Fritz Zwicky in 1950). The sky background in 0.25-kiloelectronvolt x-rays was measured on a separate rocket flight, and two new emission regions were discovered from Apollo-Soyuz.

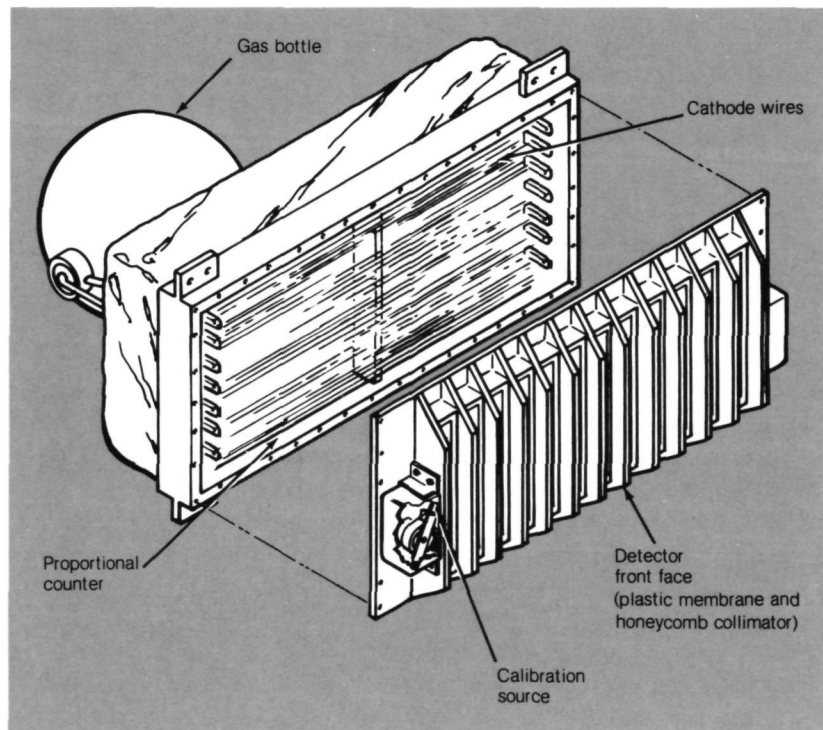

Figure 4.1 The MA-048 soft x-ray detector. The structure of the detector front acts as a collimator.

The MA-048 proportional counter (Fig. 4.1) consisted of a rigid box, 5 centimeters (2 inches) deep, with a thin plastic front window that faced outward on the side of the Apollo Service Module near the back. This plastic membrane (Kimfol polycarbonate) was only 2 micrometers thick. It was thin in order to admit soft x-rays, which are easily absorbed. The membrane was supported on the outside (against a 1.1-atmosphere pressure inside) by an aluminum honeycomb collimator with a 4° field of view. When tested before flight in a vacuum chamber, the membrane did not break but it leaked gas at 3 cm³/min. The gas had to be replaced during operations from a tank (gas bottle) on the back. This procedure required accurate valves. The gas was a mixture of 90-percent argon and 10-percent methane that was chosen for its absorption of soft x-rays. (The x-rays ionize the argon.) The pressure and temperature of the gas were measured continuously and transmitted by radio to the Mission Control Center at JSC in Houston.

Many cathode wires, grounded (at zero potential), were stretched across the box as shown in Figure 4.1, and a set of seven anode wires (at 2700 volts) was located near the front membrane. A soft x-ray photon would ionize the argon-methane gas near the front membrane; it could not penetrate to the back of the box. The freed electrons "cascaded" (Fig. 2.8) and produced more electrons. All the electrons collected on the anode wires, which recorded a current pulse proportional to the photon energy. When a cosmic ray ionized the gas near the back of the box, the current pulse was also recorded by a second set of seven anode wires (veto anodes) near the back (Fig. 4.2). This count was subtracted as in an anticoincidence detector (see Sec. 2F). The electronic counting circuit is shown in Figure 4.3. (The data anodes are near the front membrane and the veto anodes are near the back wall of the counter.) The anticoincidence gate cancels out simultaneous pulses from the data and veto anodes. The analog-digital (A-D) converter converts each pulse into binary digits and sorts pulses into 128 bins according to pulse size, thereby recording the count of 0.13-, 0.15-, 0.20- through 9.0-, and 10.0-kiloelectronvolt photons. The measured spectrum of Cygnus X-2 (the strongest source detected) is shown in Figure 4.4.

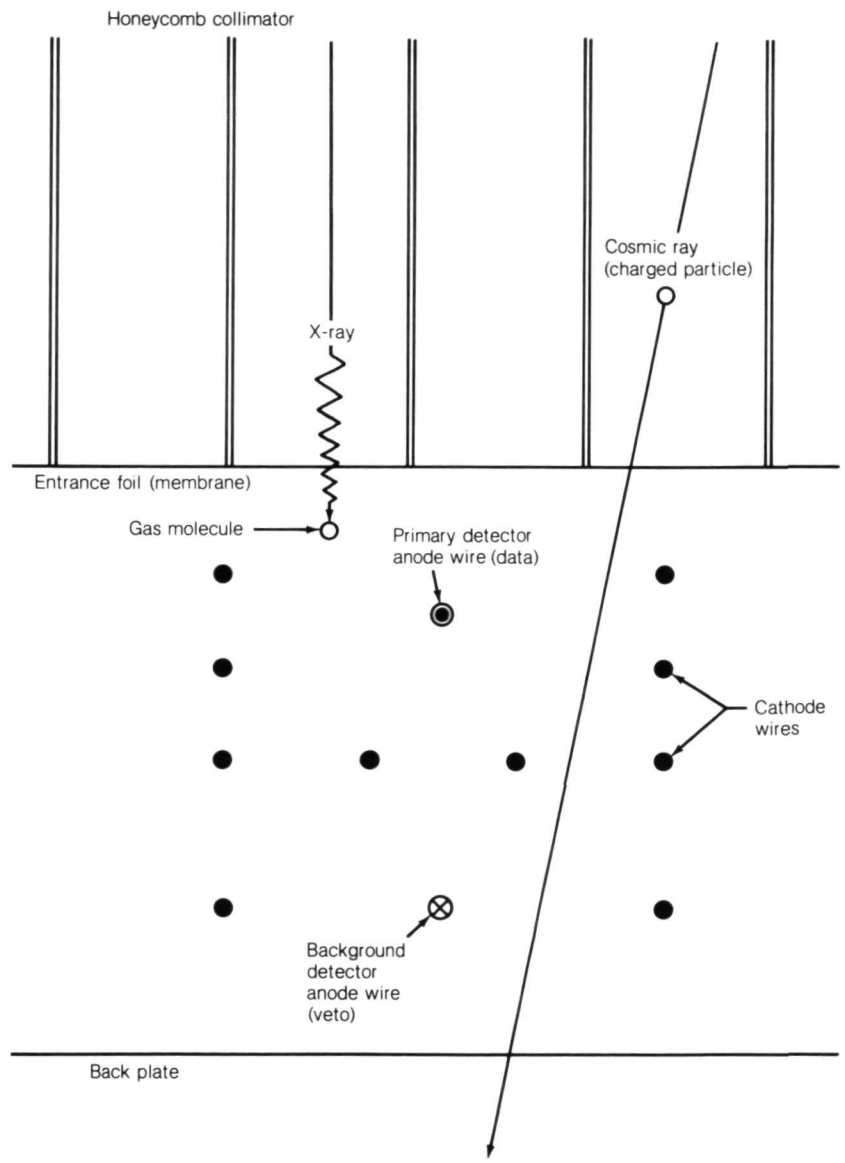
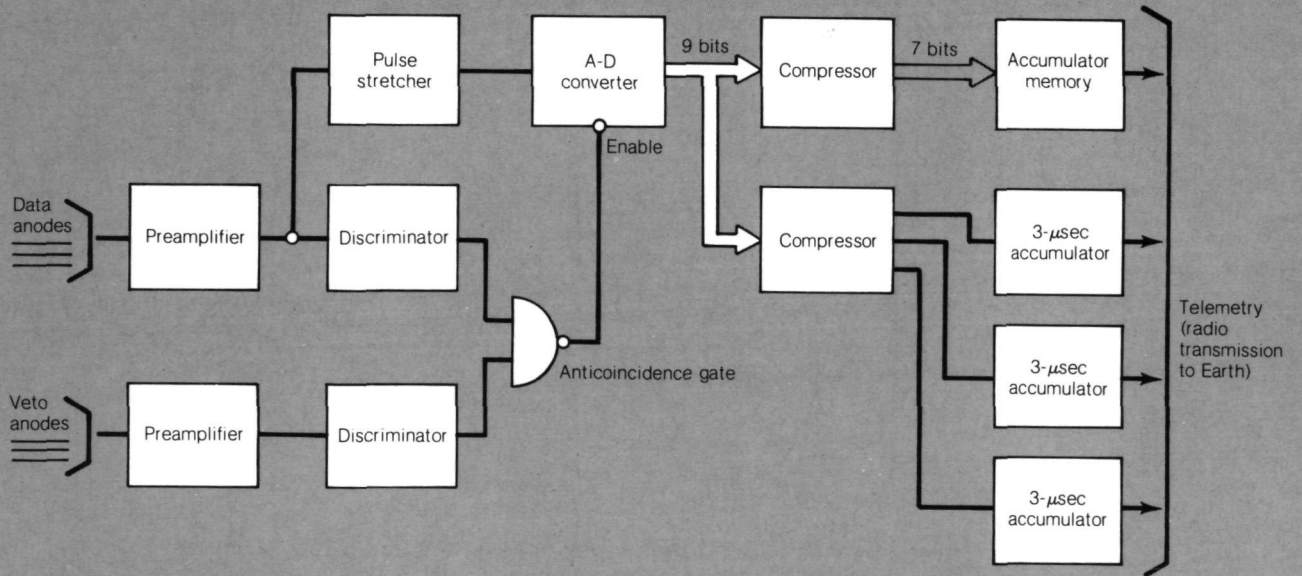

Figure 4.2 Operation of the MA-048 soft x-ray proportional counter.

Simplified block diagram of the MA-048 detector electronics system. Figure 4.3



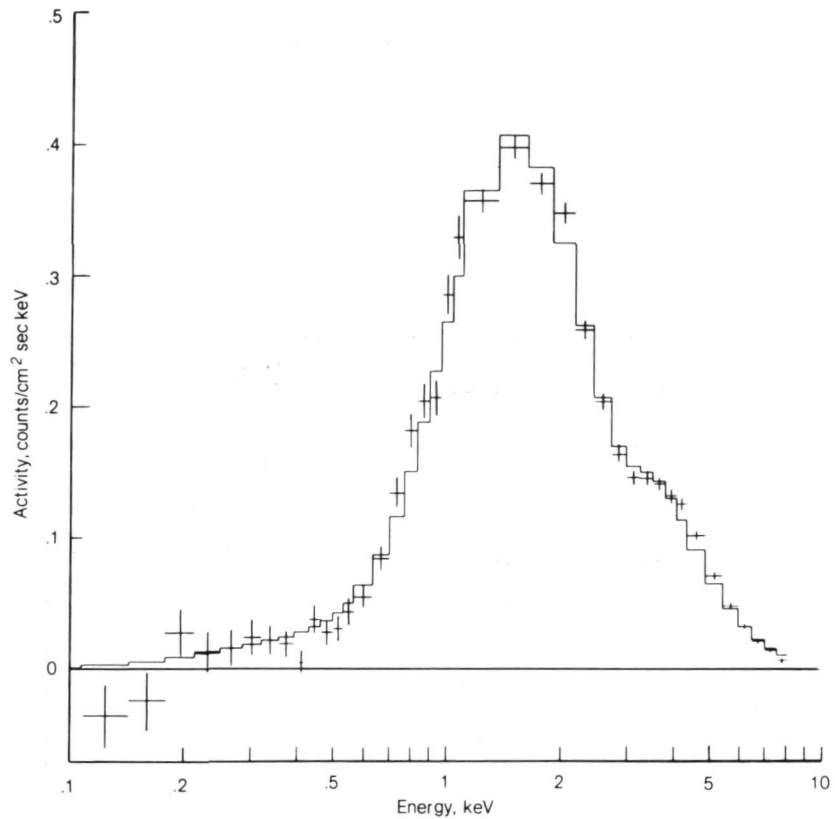

Figure 4.4 Spectrum of Cygnus X-2 observed by the MA-048 Soft X-Ray Experiment.

C MA-048 Voltage Breakdown

The MA-048 equipment was carefully calibrated in a vacuum chamber at NRL before the Apollo-Soyuz flight and checked out (voltage regulators, pressure meters, thermometers, electronics) at the NASA John F. Kennedy Space Center (KSC) just before the Apollo launch. The experiment operated successfully for 25 minutes after it was first turned on, but then a voltage breakdown occurred. A discharge (electric current) between the 2700-volt anode wires and the cathode wires or walls took place. It was probably caused by dust or small irregularities in the walls or wires where the electric field was high. The gas became continuously ionized (no pulses, therefore no counts). With the astronauts' help, the counter boxes were evacuated to hard vacuum and refilled with the argon-methane mixture, but the voltage breakdown occurred again 1 or 2 minutes after the 2700-volt potential was turned on.

It looked as if the Soft X-Ray Experiment had failed. However, because it worked for 1 or 2 minutes after being turned on, the NRL investigators at the Mission Control Center suggested turning the voltage on and off every 2 minutes. The MA-048 equipment subsequently measured soft x-rays in 1- or 2-minute intervals for an additional 30 minutes, making a total of 55 minutes of successful operation for the experiment.

D MA-048 Experiment Results—An X-Ray Pulsar

Counts were transmitted to the Mission Control Center and recorded there as a function of time. A sample set for 14 minutes 51 seconds, showing a scan across Cygnus X-2, is reproduced in Figure 4.5. The full 55 minutes of such data required many months of study to determine the voltage breakdowns, discrete sources, and soft x-ray background emission. Two broad emission regions in the background stand out. One, in the constellation Centaurus, coincides with a supernova remnant estimated by optical astronomers to be about 8000 light-years away. Its temperature is about 3 000 000 K. The other region coincides with Cygnus X-6 and is an area about 1° by 8°, estimated to be about 6600 light-years away and therefore about 110 by 1000 light-years in extent. Because a supernova remnant should be a more or less spherical nebula, this elongated x-ray source is thought to be a result of several giant-star explosions, all adding up to a 3 000 000 K temperature of the ions and electrons in an elongated region.

Another exciting discovery was an x-ray pulsar in the Small Magellanic Cloud (SMC), a galaxy of stars, gas, and dust about 200 000 light-years from us (100 000 light-years outside our Galaxy). The x-ray source SMC X-1 had been discovered in 1971, and *Uhuru* observations show that it is a close pair of stars in a 3.9-day orbit around each other. One of these is a hot blue giant star. The x-rays are cut off by an eclipse as this blue star comes between Earth and the companion star that emits x-rays (Fig. 4.6).

The soft x-ray counts from SMC X-1 measured by the MA-048 Experiment and by an earlier rocket flight with the same type of proportional counter show that SMC X-1 is not constant between eclipses. In photon energies from 1.6 to 7 kiloelectronvolts, the intensity fluctuates about 15 percent every 0.716 second. No variation was detected in the softest x-ray band (photon energy from 0.18 to 0.28 kiloelectronvolt), probably because these very soft x-rays are mostly absorbed by interstellar matter between the Earth and the SMC.

Measuring a period as short as 0.716 second was possible because the MA-048 x-ray counts were telemetered for each 3-millisecond interval. SMC X-1 is undoubtedly a pulsar, giving regular pulses of x-rays. It has a shorter period than a dozen other pulsars that have been observed. These pulsars are thought to be collapsed stars (Neutron Stars, Fig. 4.6) that are rapidly rotating and have "hotspots" on them. The two other x-ray pulsars in the Milky Way Galaxy, Centaurus X-3 and Hercules X-1, are similar.

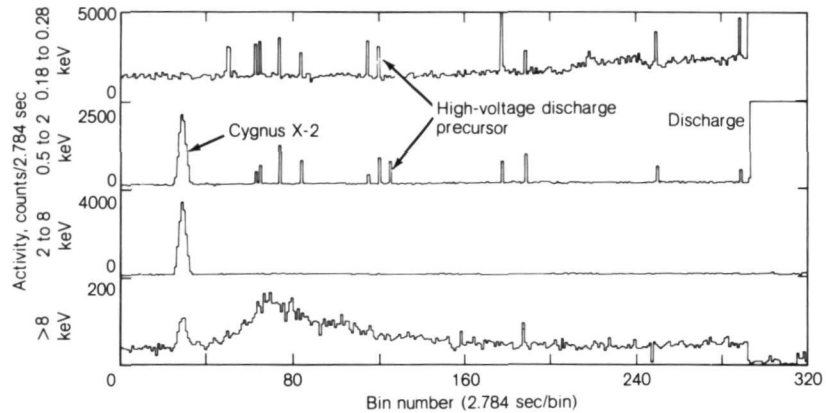
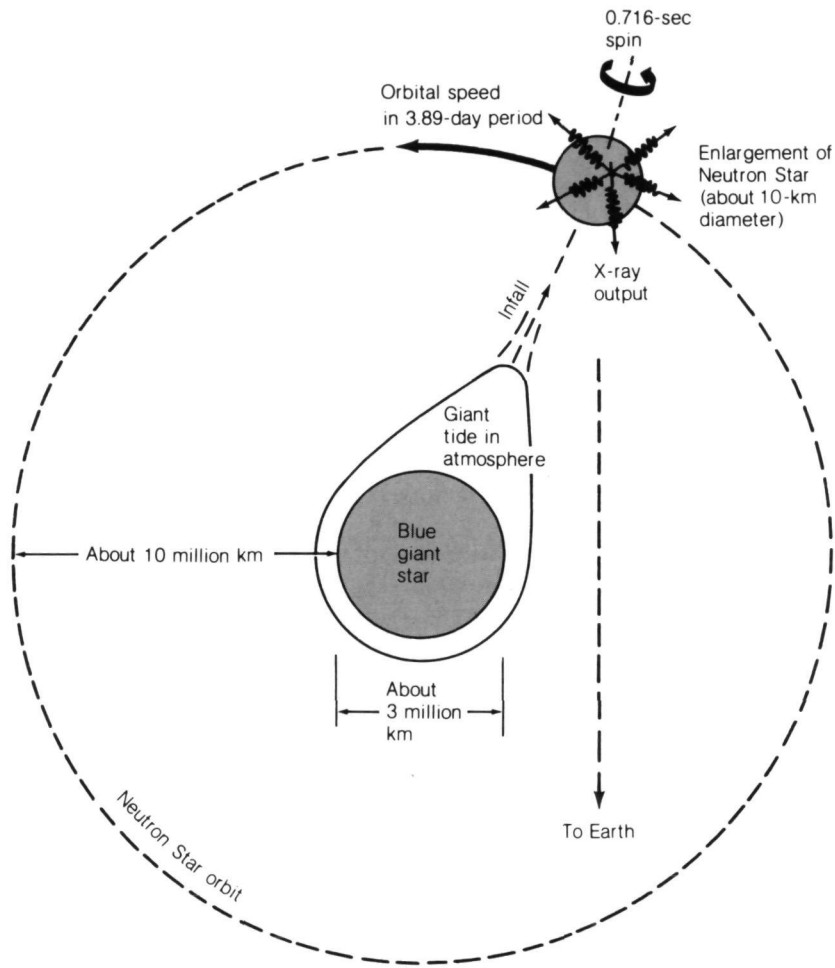

Figure 4.5 MA-048 soft x-ray count rates as a function of time for 14 minutes 51 seconds during the flight, in four energy bands.

If this theoretical model is correct, the rapidly spinning Neutron Star is a source of bremsstrahlung x-rays, probably from material falling in from a “giant tide” on the companion star. For some reason, probably its magnetic field, the Neutron Star has a hotspot where the x-ray output is well above average. As it rotates, this hotspot faces toward the Earth, then away, thus causing the periodic variations in the x-ray counts measured by the MA-048 Experiment. At 200 000 light-years, SMC X-1 has the largest intrinsic output (3×10^{31} J/sec or 3×10^{38} ergs/sec) of any known pulsar.

When the Neutron Star moves behind the blue giant star, the x-rays from SMC X-1 are eclipsed. The Doppler effect in the 0.716-second pulses of x-rays due to the orbital motion of the Neutron Star should shorten the pulses as the Neutron Star approaches the Earth and lengthen them as it recedes about 2 days later. If this Doppler effect (see Pamphlet IV) can be measured, it will confirm the model sketched in Figure 4.6 and determine the orbit size accurately. From the orbit size and period, the combined double-star mass can be calculated. (This has been done for Hercules X-1.) The “giant tide” in Figure 4.6 is less certain. If the material from the blue giant star extends beyond the neutral point between the two stars, where the gravitational forces cancel, then the gas in the giant star is spewed into the Neutron Star, as shown in Figure 4.6, providing the infall for bremsstrahlung x-rays.



Explanation of the SMC X-1 x-ray pulsar. Figure 4.6

E Questions for Discussion

(Interstellar Matter, Instrumental Calibration, Background, Black Holes, Doppler Effect)

This is just one detective study in space science, and it is by no means solved. For instance:

9. Why should the material of the blue giant star extend beyond the neutral point in Figure 4.6 when the gravitational force closer to the star is pulling it back in?

10. If you could observe Cygnus X-2 from a place much closer to it than we are, how would the spectrum differ from that in Figure 4.4?

11. The "calibration source" in Figure 4.1 contained radioactive iron-55, which emits 5.9-kiloelectronvolt x-rays. How could this have been used to check the MA-048 sensitivity during the Apollo-Soyuz mission?

12. What can account for the background of soft x-rays coming in from all directions and detected in all parts of the sky?

13. Black Holes have no material surface. There is a boundary through which no waves or particles can pass. What provides the impacts for infalling electrons generating bremsstrahlung x-rays?

14. If the Sun (with a present radius of 695 000 kilometers) were collapsed to a White Dwarf, it would have a radius of 7000 kilometers; if collapsed to a Neutron Star, a 10-kilometer radius. What happens to the material of the Sun (or any other star) in such a collapse? What about the material in a Black Hole?

15. If a Neutron Star rotating once per second is moving toward us with a velocity of 10^7 m/sec, what period of rotation would we measure from pulses of its x-ray emission (Fig 4.6)?

5 Gamma-Ray Detectors and Nuclear Reactions in a Spacecraft

A Gamma-Ray Sources and Background

Gamma-ray photons have the highest energy—from 100 kiloelectronvolts to 1000 megaelectronvolts and higher. They can be generated in the same manner as x-rays are generated. They could be bremsstrahlung from cosmic-ray impacts, or synchrotron radiation from cosmic rays passing through magnetic fields, or the result of the inverse Compton effect on hard x-rays. Specific gamma-ray energies come from the decay of pi mesons (“heavy electrons” produced by cosmic rays); from nuclear reactions; and from matter-antimatter annihilation such as proton-antiproton annihilations, which produce 100-megaelectronvolt photons, and electron-positron annihilations, which produce 0.5-megaelectronvolt photons. Specific gamma-ray energies from nuclear reactions are used in physics laboratories to identify the nuclear reactions that are taking place in an experiment.

The penetrating power of gamma rays is so great that they pass through interstellar material virtually without loss. Strangely enough, theory shows that very high energy (more than 10^5 megaelectronvolts) gamma rays experience a loss in space by interacting with the residual millimeter-wave radiation (a leftover from the “Big-Bang” origin of the universe) to form electron-positron pairs. Because they are generated by cosmic rays, gamma rays were expected to come mainly from a general background all over the sky rather than from discrete (isolated) sources. However, several strong x-ray sources (such as the Crab Nebula) have been found to be gamma-ray sources also.

B Gamma-Ray Detectors

The detection of gamma-ray background and sources depends on crystal scintillators (Sec. 2F)—large crystals of germanium or thallium-doped sodium iodide. (“Thallium-doped” means a small amount of thallium was added during the manufacture of the crystal.) One difficulty with these detectors is the “instrumental background,” flashes that are *not* due to gamma rays from outside. The rate of these flashes must be determined during preflight calibration. Experiments on previous Apollo flights showed that this background count increased during the flight, probably because cosmic rays and secondary rays were absorbed in the crystal and created radioactive isotopes there. (The secondaries include the neutrons released when cosmic rays are absorbed in nearby materials in the spacecraft.) Gamma rays are released as the radioactive isotopes decay inside the crystal and are counted the same as if they came from outside.

C The Crystal Activation Experiment, MA-151

To measure the background change, two standard gamma-ray detector crystals were carried in Apollo-Soyuz and checked for background flashes shortly after the 9-day flight. In the Crystal Activation Experiment, MA-151, three other laboratories cooperated with GSFC in testing the crystals and other materials after the flight. These tests were coordinated by J. I. Trombka at GSFC.

Figure 5.1 is a diagram of the sodium iodide crystal in its steel cylinder with a glass end-window through which a photomultiplier tube could “look” for background flashes in preflight and postflight tests. Such a crystal scintillator could be used to detect 0.2- to 10-megaelectronvolt gamma rays, but it would need some sort of anticoincidence plastic scintillator around it, as in Figure 2.9.

Figure 5.2 shows how materials were packed in the other container: a smaller germanium detector and 100-gram sheets of scandium, yttrium, and uranium, which are used as shields and filters in gamma-ray counters. Both packages were mounted on the inside wall of the Apollo Command Module and were recovered 80 minutes after splashdown on July 24, 1975. In this inside position, the samples were exposed to both solar and galactic cosmic rays, to the gamma-ray and neutron secondaries from nearby spacecraft materials (mostly aluminum, steel, and plastics), and to Van Allen belt protons (see Glossary) for a total of 217 hours. A similar experiment had been performed on the Apollo 17 mission to the Moon.

Several tests were completed on the recovery ship within a few hours after splashdown. The instrumental background flashes in the sodium iodide and germanium crystals increased from those of the preflight tests, and the gamma-ray spectrum showed which radioactive isotopes were created by the exposure. Figure 5.3 is a plot of the gamma-ray spectrum from inside the thallium-doped sodium iodide crystal. The Apollo-Soyuz results are about one-third the level of the Apollo 17 counts, with each energy channel counted for 20 minutes. The energy channels are each 2.5 kiloelectronvolts wide, ranging from 25 kiloelectronvolts to 1.25 megaelectronvolts. The peaks are due to the spontaneous decay of three radioactive isotopes of iodine, one of indium, and one of tellurium. Sodium-24 (sodium isotope of atomic weight 24) was also detected. The lower energy x-ray spectrum from inside the germanium crystal is plotted in Figure 5.4, which shows 10-kiloelectronvolt x-rays from gallium-67 and germanium-71. Zinc-65 and cobalt-56 were also detected.

The metal foils were also activated by the exposure, giving scandium-46, neptunium-239 (from uranium), yttrium-87, and zirconium-89 (from yttrium). The last isotope, produced by neutron capture, showed a

background of 0.71 thermal neutron/cm² sec in the Apollo spacecraft. These data, together with much other information collected on earlier Skylab and Apollo missions, will make possible the proper design and operation of future high-energy experiments in space.

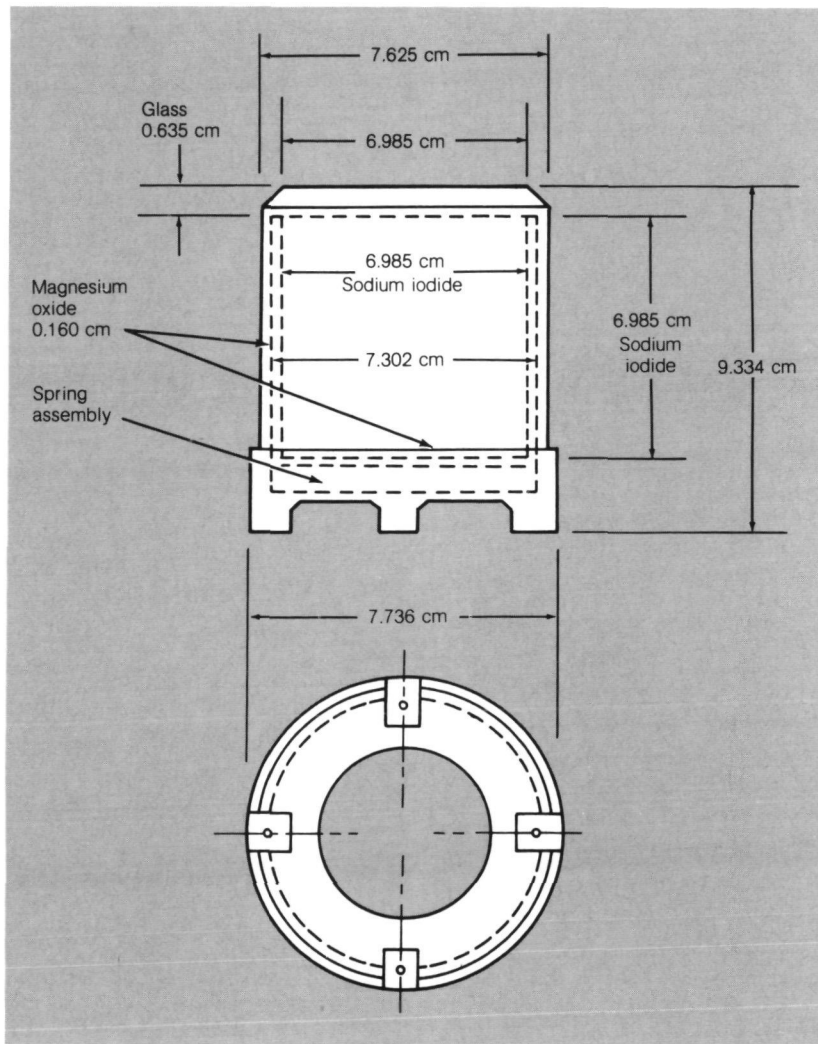

Diagram of the sodium-iodide crystal and cell for the MA-151 Experiment.

Figure 5.1

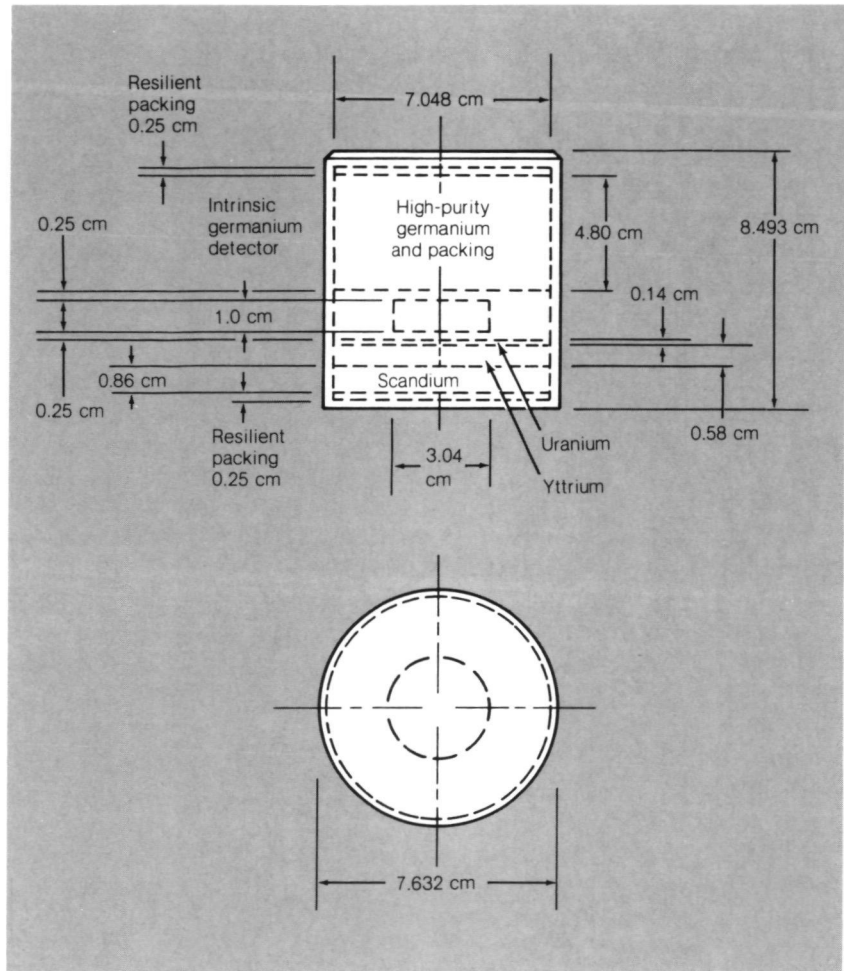
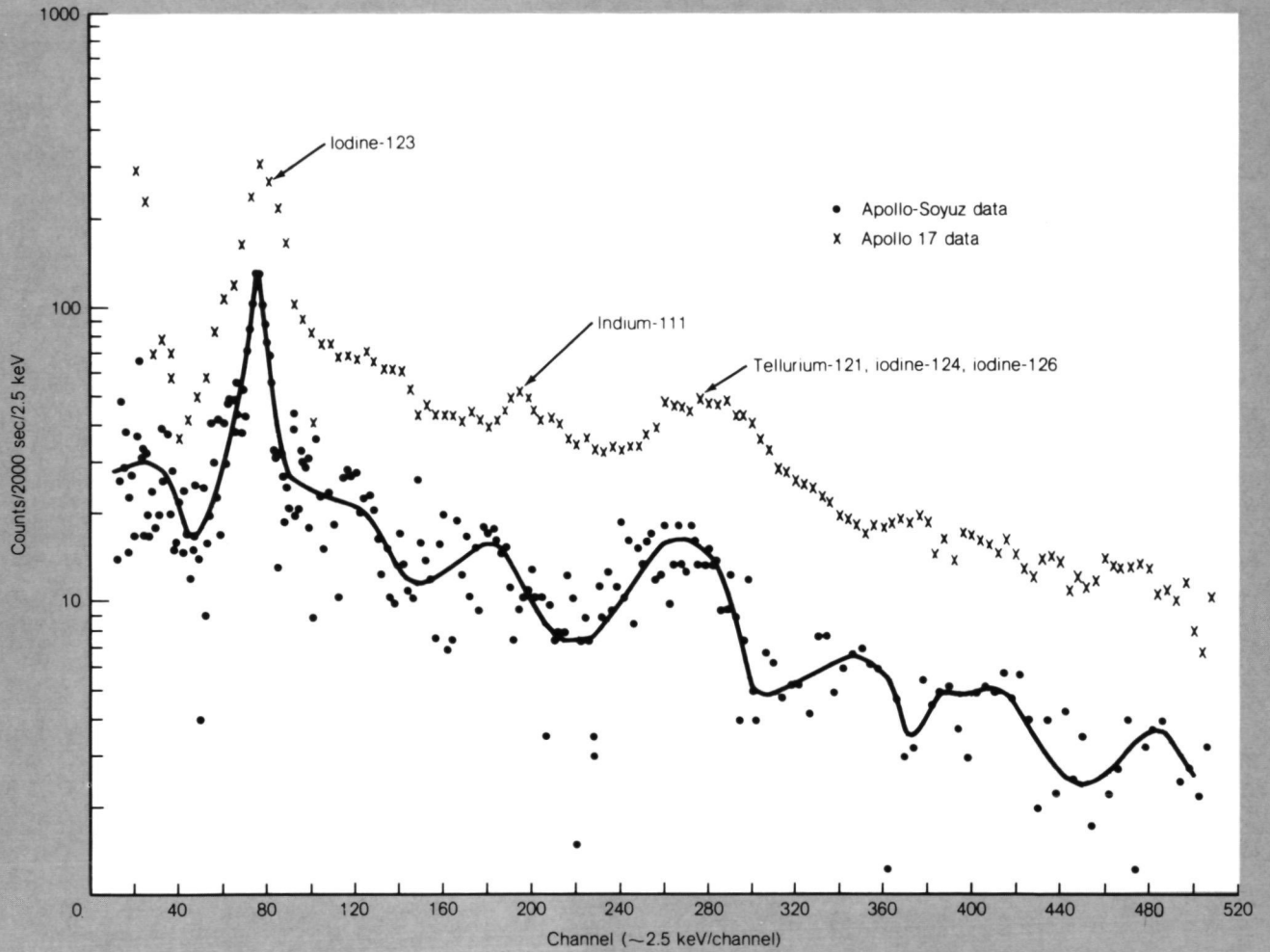

Figure 5.2 Diagram of the MA-151 container holding the germanium crystals and metals.

Graph of postflight MA-151 counts in the sodium-iodide crystal compared with Apollo 17 postflight counts. Figure 5.3



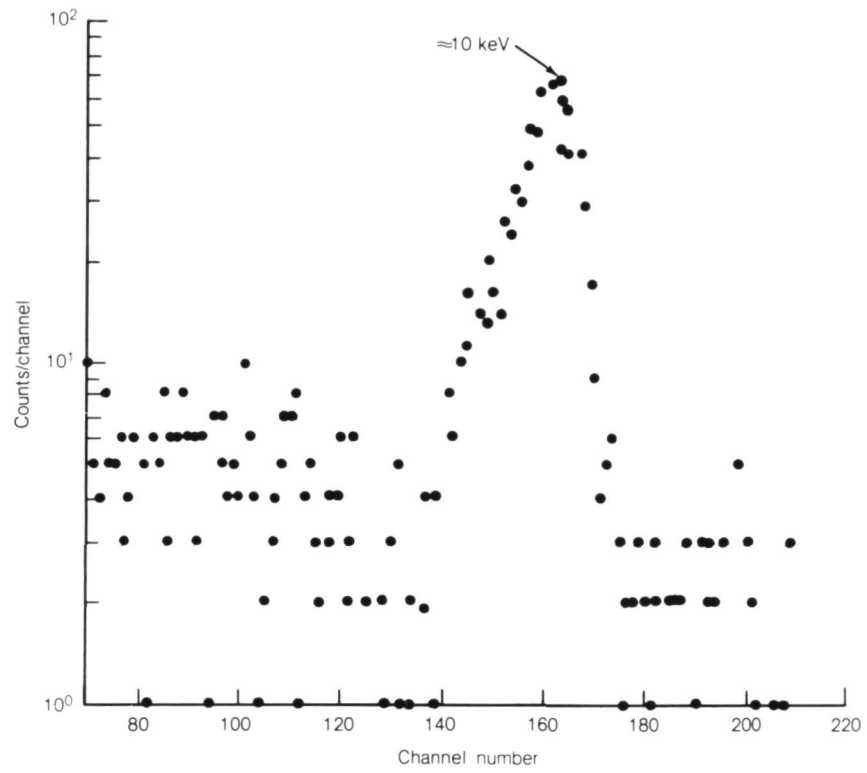

Figure 5.4 Graph of postflight counts in the germanium crystal showing the 10-kiloelectronvolt peak contributed by gallium-67 and germanium-71 (440-minute count time at 0.066 keV/channel).

6 Conclusions

During the last 10 years, high-energy astrophysics has become one of the most interesting research studies in space science. X-ray and gamma-ray observations have shown that things are going on in our Milky Way Galaxy, and beyond it, that were not even suspected in 1960. Such observations, including the MA-048 Soft X-Ray results from Apollo-Soyuz, have almost confirmed the existence of Neutron Stars and Black Holes, which were purely speculative theories as late as 1965. As space techniques and instruments—sensitive detectors of soft x-rays and accurate detectors of gamma rays—are improved, we will learn more about the strange sources scattered throughout our Milky Way and other galaxies.

Appendix A

Discussion Topics (Answers to Questions)

1. (Sec. 3E) Ultraviolet sunlight, solar x-rays, and cosmic rays are harmful to most living organisms and cause genetic mutations (refer to a biology text). If they were not absorbed, the atmosphere would be heated entirely from the bottom, causing more turbulence and changing wind patterns. Surface temperatures would be lowered because of the lack of the "greenhouse effect" (holding in infrared "heat waves" because the atmosphere is opaque to them). If this had always been the case, animal life would probably have remained in the seas.

2. (Sec. 3E) The 20 000 volts produce electrons in the scanning beam with energies of 20 kiloelectronvolts (a little less because of the work needed to pull each electron out of the cathode). Because several electrons are needed for each of three colors in each of 276 000 pixels, at least 5 520 000 x-ray photons of 20-kiloelectronvolt energy are produced each second at the back of the television screen. Most of these bremsstrahlung x-rays are absorbed in the back and sides of the television set, but about 20 percent come out the front.

3. (Sec. 3E) If the wavelength is zero, $f = c/\lambda = \text{infinity}$, and the photon energy $E = hf$ is infinite. Therefore, even a superhot body cannot radiate at zero wavelength (refer to the Planck Law).

4. (Sec. 3E) Cosmic rays are generated by the Sun and other stars in varying amounts. (Studies of the lunar soil may indicate such changes in solar cosmic rays during the past.) New galactic cosmic rays are probably accelerated to very high energies by "collisions" with magnetic fields in the huge interstellar clouds of the Galaxy. Thus, there are many sources of new cosmic rays to replace the rays that are absorbed.

5. (Sec. 3E) Identification of an x-ray source with an optical object whose distance can be estimated is the best method to date. Independent estimates may be possible when complete x-ray spectra can be measured, from which (a) intrinsic x-ray output can be inferred or (b) soft x-ray absorption along the line of sight can be measured.

6. (Sec. 3E) More complete measurements should be made of x-ray spectra, including gamma rays; rapid time variations in x-ray intensity and spectrum; polarization of the x-rays; and greater angular resolution and accuracy of the source position.

7. (Sec. 3E) As a high-speed electron spirals around magnetic lines of force and radiates photons, its kinetic energy is reduced by an amount equal to the photon energy radiated.

8. (Sec. 3E) Synchrotron radiation from cosmic rays moving through the Galaxy's magnetic field should produce a background of x-rays and gamma rays close to the Galactic Equator; that is, in the disk of the Milky Way Galaxy (see Fig. 3.5).

9. (Sec. 4E) In Section 4D and in Figure 4.6, the escape of gas from the gravitational field of the blue giant star can be caused by convection and radiation pressure in the atmosphere of that star. In fact, as stars age, they tend to increase in size.

10. (Sec. 4E) Because the interstellar material absorbs more of the very soft x-rays than of the harder x-rays (higher photon energy), the spectrum of Cygnus X-2, as recorded much closer to it, would be higher in the low-energy (left) side than is shown in Figure 4.4.

11. (Sec. 4E) When the calibration source was pushed in front of the left side of the MA-048 detector, its known intensity of 5.9-kiloelectronvolt x-rays (about 500 photons/sec) would enter the detector through the thin plastic front window just like x-rays from a cosmic source. If the proportional counter recorded 500 more counts/sec above the background count in the 5.9-kiloelectronvolt bin, then its sensitivity was correct. If not, a correction would need to be made to the instrument readings.

12. (Sec. 4E) The background of soft x-rays coming in from all directions might be synchrotron radiation from electrons and protons in the solar wind passing through the Earth's magnetic field and synchrotron radiation of other protons and electrons farther away that have been fired into the magnetic field of the Milky Way Galaxy. Or it could be many more distant sources, overlapping, all over the sky.

13. (Sec. 4E) Reasoning about conditions at the "Schwarzschild Discontinuity," the "edge" of a Black Hole at distance R_S from its center of mass, is tricky. The equation $R_S = 2GM/c^2$ can be derived from the formula for escape velocity, $mv_e^2 = 2GmM/R$ for test mass m at distance R from a large mass M , by letting v_e approach the velocity of light c . In the time frame of the falling mass m , it takes infinite time to cross the $R = R_S$ discontinuity. However, it is unlikely that infalling material will fall directly toward M ; most of it will go into an orbit that is slowly circularized by collisions. X-ray bremsstrahlung will come from impacts of new material with material in orbit outside R_S .

14. (Sec. 4E) If the solar radius, which encloses about 2×10^{30} kilograms at a mean density of 1.4 gm/cm^3 , is shrunk to a 7000-kilometer-radius White Dwarf star with the same mass, the density must increase by a factor of 1 million. This high-density material is no longer a normal gas and is called degenerate, with all electrons compressed into the lowest atomic orbits. If the collapse starts at a higher rate, gravitational force modifies atomic nuclei into neutrons with even higher density: $(7000/10)^3(1\ 400\ 000) = 4.8 \times 10^{14} \text{ gm/cm}^3$. Further compression forms a Black Hole with a radius R_s of 3 kilometers.

15. (Sec. 4E) The Doppler effect (see Pamphlet IV) will decrease the observed period of rotation or increase the frequency f of x-ray pulses from 1.0 per second to 1.1 per second. When a source is approaching Earth at velocity v , the frequency of its output (light or pulses) is increased by Δf , where $f/(f + \Delta f) = v/c$, and c is the velocity of the light or pulses, $3 \times 10^8 \text{ m/sec}$, which is the velocity of x-ray pulses on the way from the pulsar to Earth. The same Doppler formula applies to sound waves, which have a velocity much less than c . The observed period of the rotating Neutron Star is decreased from 1.00 to 0.91 second.

Appendix B

SI Units Powers of 10

International System (SI) Units

Names, symbols, and conversion factors of SI units used in these pamphlets:

Quantity	Name of unit	Symbol	Conversion factor
Distance	meter	m	1 km = 0.621 mile 1 m = 3.28 ft 1 cm = 0.394 in. 1 mm = 0.039 in. 1 μm = 3.9×10^{-5} in. = 10^4 \AA 1 nm = 10 \AA
Mass	kilogram	kg	1 tonne = 1.102 tons 1 kg = 2.20 lb 1 gm = 0.0022 lb = 0.035 oz 1 mg = 2.20×10^{-6} lb = 3.5×10^{-5} oz
Time	second	sec	1 yr = 3.156×10^7 sec 1 day = 8.64×10^4 sec 1 hr = 3600 sec
Temperature	kelvin	K	273 K = 0°C = 32°F 373 K = 100°C = 212°F
Area	square meter	m ²	1 m ² = 10^4 cm ² = 10.8 ft ²
Volume	cubic meter	m ³	1 m ³ = 10^6 cm ³ = 35 ft ³
Frequency	hertz	Hz	1 Hz = 1 cycle/sec 1 kHz = 1000 cycles/sec 1 MHz = 10^6 cycles/sec
Density	kilogram per cubic meter	kg/m ³	1 kg/m ³ = 0.001 gm/cm ³ 1 gm/cm ³ = density of water
Speed, velocity	meter per second	m/sec	1 m/sec = 3.28 ft/sec 1 km/sec = 2240 mi/hr
Force	newton	N	1 N = 10^5 dynes = 0.224 lbf

Quantity	Name of unit	Symbol	Conversion factor
Pressure	newton per square meter	N/m ²	1 N/m ² = 1.45 × 10 ⁻⁴ lb/in ²
Energy	joule	J	1 J = 0.239 calorie
Photon energy	electronvolt	eV	1 eV = 1.60 × 10 ⁻¹⁹ J; 1 J = 10 ⁷ erg
Power	watt	W	1 W = 1 J/sec
Atomic mass	atomic mass unit	amu	1 amu = 1.66 × 10 ⁻²⁷ kg

Customary Units Used With the SI Units

Quantity	Name of unit	Symbol	Conversion factor
Wavelength of light	angstrom	Å	1 Å = 0.1 nm = 10 ⁻¹⁰ m
Acceleration of gravity	g	g	1 g = 9.8 m/sec ²

Unit Prefixes

Prefix	Abbreviation	Factor by which unit is multiplied
tera	T	10^{12}
giga	G	10^9
mega	M	10^6
kilo	k	10^3
hecto	h	10^2
centi	c	10^{-2}
milli	m	10^{-3}
micro	μ	10^{-6}
nano	n	10^{-9}
pico	p	10^{-12}

Powers of 10

Increasing

$10^2 = 100$

$10^3 = 1\ 000$

$10^4 = 10\ 000$, etc.

Examples:

$2 \times 10^6 = 2\ 000\ 000$

$2 \times 10^{30} = 2$ followed by 30 zeros

Decreasing

$10^{-2} = 1/100 = 0.01$

$10^{-3} = 1/1000 = 0.001$

$10^{-4} = 1/10\ 000 = 0.000\ 1$, etc.

Example:

$5.67 \times 10^{-5} = 0.000\ 056\ 7$

Appendix C

Glossary

References to sections, Appendix A (answers to questions), and figures are included in the entries. Those in *italic* type are the most helpful.

angstrom (\AA) a unit of wavelength used by physicists for more than 80 years:

1 angstrom = 10^{-10} meter or 0.1 nanometer.

angular resolution the angle between two sources that can just be distinguished by a detector and collimator. The normal human eye has an angular resolution of 1 arc-minute. (Sec. 2D; Figs. 2.6, 3.3)

anode a positively charged wire in a vacuum tube or detector which attracts electrons. (Secs. 4B, 4C; Figs. 2.7, 2.8, 4.2)

anticoincidence counter a photon detector that automatically cancels counts that are due to cosmic rays or other rays that are not wanted in the count. (Secs. 2C, 2F, 4B, 5C; Fig. 2.9)

arc-minute a unit of angle: $1^\circ = 60$ arc-minutes, 1 arc-minute = 60 arc-seconds.

background a uniform intensity over a region of sky around the star under study (Secs. 4B, 4D, 5A to 5C; App. A, nos. 8, 12). "Instrumental background" (Sec. 5B) is the count rate due to instrument defects when no photons are entering the detector.

"Big-Bang" cosmology the theory of the origin of the universe which states that the universe was created about 15 billion years ago when a giant explosion emitted high-frequency radiation and pushed matter apart. That matter is now condensed into stars in galaxies which are receding from the Earth. The more distant ones are receding faster because they started faster in the Big Bang. (Sec. 5A)

Black Hole a collapsed mass of extremely high density that curves space near it so that no light or particles can get in or out. (Secs. 1, 3D, 4E, 6; App. A, nos. 13, 14)

bremstrahlung electromagnetic radiation (photons) produced by impacts of high-speed electrons or ions on other material. (Secs. 3D, 4D, 5A; App. A, nos. 2, 13; Fig. 3.7)

cathode a negatively charged wire in a vacuum tube or detector. (Secs. 4B, 4C; Figs. 2.7, 2.8, 4.2)

Cerenkov radiation the visible light emitted by a particle traveling near the speed of light when it enters a substance where the velocity of light is less than the particle's speed. (Sec. 4F; Fig. 2.9) See Pamphlet VI.

channeltron a curved vacuum tube that gives a 100-million-electron output pulse for each electron input. (Sec. 2E) See Pamphlet III.

collimator one or more tubes in front of a detector that allow photons from only one direction to reach the detector. (Secs. 2D, 2F, 3B, 4B; Figs. 2.6, 4.1, 4.2)

Compton effect a loss of energy from a photon to an electron near an ion.

The *inverse Compton effect* is a gain of photon energy from an electron.

(Secs. 3D, 5A; Figs. 3.9, 3.10) See Project Physics, Sec. 20.2; PSSC, Sec. 25-4.

constellation a group of stars, such as the Big Dipper, that defines an area (generally 10° or 20° across) in the sky. Most of the constellations were named by the Greeks (Taurus, Scorpius, Cygnus). (Sec. 3A; Fig. 3.5)

cosmic ray an extremely high speed ion; a stripped atomic nucleus. Solar cosmic rays are blown out of the Sun; galactic cosmic rays arrive from all directions. (Secs. 1, 2C, 2F, 3D, 4B, 5A; App. A, nos. 1, 4; Fig. 2.4)

count one pulse of current or voltage from a detector, indicating the passage of a photon or cosmic ray through the detector. (Secs. 2C, 2D to 2F, 3B)

count rate the number of counts per second; it measures the intensity of the source. (Secs. 2C, 2D, 2E, 3B)

crystal a solid composed of atoms or ions or molecules arranged in a regular repetitive pattern. Sodium iodide and germanium crystals are used as gamma-ray detectors. (Secs. 2F, 5B, 5C; Figs. 2.9, 5.1, 5.2)

declination angular distance north (plus) or south (minus) of the Celestial Equator in the sky. (Sec. 3C; Fig. 3.4) See Project Physics, Secs. 5.1 to 5.3.

Doppler shift the change of frequency and wavelength in the spectrum of a source approaching or receding from an observer. (Sec. 4D; App. A, no. 15) See Pamphlet IV.

electric field strength of the electric force on a unit electric charge in a region of space affected by other electric charges. (Secs. 2A, 3D)

electromagnetic waves include x-rays, light waves, and radio waves, which carry energy at a velocity c of 3×10^8 m/sec. The electromagnetic spectrum is the sequence of wavelengths from very short gamma rays to very long radio waves. (Secs. 2A, 2B, 3D; Fig. 2.2)

electronvolt (eV) a unit of photon energy; 1000 electronvolts = 1 kiloelectronvolt; 1000 kiloelectronvolts = 1 megaelectronvolt. (Sec. 2B)

energy (E) the capacity for doing work. The energy of motion, kinetic energy is $\frac{1}{2}mv^2$. The energy of radiation, including light and x-rays, comes in photons. Each photon has an energy $E = hf = hc/\lambda$, where h is the Planck constant, f is the frequency, c is the velocity, and λ is the wavelength of the light or x-rays. Photon energy is measured in electronvolts. X-rays have photon energies from about 100 electronvolts (soft) to 50 kiloelectronvolts (hard). *High-energy astrophysics* is the study of high-energy photons. (Secs. 2B, 3D, 5A, 5C; App. A, nos. 3, 7, 10; Figs. 3.7, 3.9, 3.10, 4.4)

- filter** a thin slab of selective material in front of a detector. The filter lets through only a selected color or group of wavelengths or group of photon energies. (Secs. 2C, 5C)
- frequency (f)** the number of oscillations made by a wave each second, measured in hertz. The frequencies of x-rays are between 3×10^{16} and 3×10^{19} hertz. Photon energy is hf , where h is the Planck constant. (Secs. 2A, 2B; Fig. 2.2)
- galaxy** a vast assemblage of billions of stars with interstellar gas and dust. See *Milky Way*. (Sec. 3C; Fig. 3.6)
- gamma rays** very high energy photons of energy greater than about 100 kiloelectronvolts. (Secs. 1, 2A to 2C, 2F, 3D, 5A to 5C; Figs. 2.2, 2.4, 2.9)
- gravitation** the force of attraction between two masses, given by Newton's Law. (Sec. 3D) See Project Physics, Secs. 8.6 to 8.8; PSSC, Secs. 13-8, 13-10.
- hertz (Hz)** a unit of frequency, one oscillation (cycle) per second; 1 kilohertz = 1000 cycles/sec, 1 megahertz = 10^6 cycles/sec.
- infrared (IR)** invisible electromagnetic radiation with wavelengths from 0.7 to 1000 micrometers; longer than visible wavelengths. (Sec. 2A; App. A, no. 1; Fig. 2.2)
- interstellar gas and dust** material in the space between stars. Low-density hydrogen and other gases are detected from their absorption and emission of specific wavelengths of light and radio waves. Fine dust particles scatter light like smog does. (Secs. 3C, 4A; App. A, nos. 4, 10)
- intrinsic power** the energy radiated per second from an x-ray (or light) source. The brightness that we see is the intrinsic power divided by the square of the source distance, minus the absorption by interstellar smog. (Secs. 3C, 3D, 4D)
- ion** an atom with one or more electrons removed or, more rarely, added. (Atoms are ionized by heat or light, x-rays and gamma rays, and cosmic rays or other moving particles.) *Ionization* in a detector shows the intensity and photon energy of x-rays. (Secs. 2C, 2E, 3D; Figs. 2.7, 2.8, 3.10) See Project Physics, Secs. 18.4, 18.5; PSSC, Secs. 25-2, 25-3.
- kelvin (K)** a temperature scale starting at absolute zero (no heat motion). $273 \text{ K} = 0^\circ \text{ C} = 32^\circ \text{ F}$, the freezing point of water; $373 \text{ K} = 100^\circ \text{ C} = 212^\circ \text{ F}$, the boiling point of water on Earth.
- Large Magellanic Cloud (LMC)** see *Magellanic Clouds*.
- light-year** the distance light travels (at 3×10^8 m/sec) in 1 year (3.15×10^7 seconds). One light-year equals 9.46×10^{12} kilometers, about 63 000 times the distance from Sun to Earth. (Secs. 3A, 3C, 4A, 4D; Fig. 3.6)
- MA-048** the Soft X-Ray Experiment on the Apollo-Soyuz mission. (Secs. 1, 4B to 4D; Figs. 4.1, 4.2, 4.3)

- MA-151** the Crystal Activation Experiment on the Apollo-Soyuz mission. (Secs. 1, 5C; Figs. 5.1, 5.2)
- Magellanic Clouds** two irregular-type galaxies close to the Milky Way Galaxy, visible only from the Southern Hemisphere of the Earth. (Secs. 3B, 3C, 4B, 4D; Fig. 3.5)
- magnetic field (H)** the strength of the magnetic force on a unit magnetic pole in a region of space affected by other magnets or electric currents. (Secs. 2A, 3D, 4D; App. A, nos. 4, 12; Fig. 3.8)
- Milky Way** a band of stars, visible only on a clear, dark night, stretching completely around the sky. Using the distances of the stars, astronomers can plot the Milky Way Galaxy, a disk-shaped group of more than 100 billion stars, including our Sun. (Sec. 3C, App. A, nos. 8, 12; Fig. 3.6)
- neutron** an atomic particle with a mass slightly larger than that of a proton (hydrogen ion) but no charge. A *Neutron Star* is made almost entirely of neutrons. (Secs. 1, 3D, 4D, 4E, 6; App. A, no. 14; Figs. 3.7, 4.6)
See *stars, pulsar*.
- photon** a quantum of light—the smallest separable amount of energy in a beam of light or x-rays. Photon energy is proportional to frequency. The high-energy photons of x-rays or gamma rays are counted individually by detectors. (Secs. 2B, 5A; App. A, nos. 3, 7)
- polarized** waves that vibrate in a definite pattern. Ordinary light and radio waves are unpolarized; they oscillate in all directions around the line of sight. Plane-polarized waves oscillate in one direction (in one plane), like a clothesline jiggled up and down only. Circular polarization corresponds to cranking one end of the clothesline round and round. (Sec. 3D; Fig. 3.8) See Project Physics, Sec. 13.7.
- pulsar** a pulsating star of a type first detected by regular 1-second pulses of radio waves, now thought to be a rapidly rotating Neutron Star with a “hotspot” on one side. (Sec. 4D)
- quantum** see *photon*.
- radioactivity** the property of spontaneously ejecting alpha or beta particles and sometimes gamma rays. A few elements and many isotopes are radioactive. Radioactive isotopes can be formed when an atom is bombarded by cosmic rays, high-speed protons, or neutrons. (Secs. 5B, 5C)
- right ascension** angle in the sky measured from a point in the constellation Aries, usually expressed in hours and minutes of Earth’s rotation time (24 hours = 360°, 1 hour = 15°). Used as a coordinate (like longitude on Earth) to measure position in the sky. (Sec. 3C; Fig. 3.4) See Project Physics, Secs. 5.1 to 5.3.
- scintillation** a flash of visible light when a gamma ray or cosmic ray is absorbed in a crystal or a plastic. (Sec. 2F; Fig. 2.9)

Small Magellanic Cloud (SMC) see *Magellanic Clouds*.

soft x-rays photons with energy from 100 electronvolts to 10 kiloelectronvolts. They are more easily absorbed than hard x-rays. (Secs. 2C, 3D, 4A to 4D; App. A, nos. 10, 12; Figs. 4.4, 4.5) See Project Physics, Sec. 18.6; PSSC, Sec. 23-9.

spectrum the sequence of electromagnetic waves from small (gamma rays) to large (radio waves). (Secs. 2A, 4B; App. A, no. 10; Figs. 2.1, 2.2, 4.4, 5.3, 5.4)

star a very hot ball of gas with an energy source near the center. Normal stars are like the Sun, about 10^6 kilometers in diameter. Blue stars are much hotter than the Sun. Giant stars are 200 times larger and White Dwarf stars 100 times smaller than the Sun. Neutron Stars and Black Holes are smaller still. Many stars are double (Sec. 4D)—that is, two stars orbiting around each other. (Secs. 3D; App. A, nos. 9, 14; Figs. 3.7, 4.6)

supernova the explosion of a giant star after its hydrogen is mostly converted to helium and its core collapses. A large fraction of its mass is blown outward to form a nebula (*supernova remnant*). (Secs. 3A, 3D, 4A, 4D)

synchrotron radiation radiation produced by high-speed electrons or ions spiraling around lines of force in a magnetic field. The light and x-rays emitted are polarized. (Secs. 3D, 5A; App. A, nos. 8, 12; Fig. 3.8)

Uhuru the Explorer 42 satellite devoted entirely to x-ray astronomy. Launched on December 12, 1970, the seventh anniversary of Kenyan independence, the satellite was named *Uhuru*, which means “freedom” in the local Swahili language. (Secs. 3B, 3C, 4D)

ultraviolet (UV) invisible light of wavelengths less than 4000 angstroms (400 nanometers), shorter than those of visible light. (Sec. 2A; App. A, no. 1; Fig. 2.2)

Van Allen belt a doughnut-shaped region around the Earth from 320 to 32 400 kilometers (200 to 20 000 miles) above the magnetic equator, where high-speed protons and electrons oscillate north-south in the Earth’s magnetic field. (Sec. 5C)

wavelength (λ) the distance from the crest of one wave to the crest of the next, usually measured in angstroms. The wavelengths of x-rays are from 0.1 to 100 angstroms. (Secs. 2A, 2B; App. A, no. 3; Fig. 2.2)

White Dwarf a compact star of high density, about the size of the Earth. More than 100 White Dwarfs have been observed. (Secs. 3D, 4B, 4E; App. A, no. 14)

x-rays electromagnetic radiation of very short wavelength and high photon energy. (Secs. 1, 2A, 2B, 2C, 3A, 3C, 3D, 4A; App. A, no. 1; Figs. 2.2 to 2.4)

Appendix D

Further Reading

- The Amazing Universe* by Herbert Friedman, National Geographic Society (Washington, D.C.), 1975—see especially the chapters on rocket, balloon, and satellite observations and on the Sun and Black Holes.
- Astronomy Made Simple* by Meir H. Degani, Doubleday & Co., Inc. (New York), 1963—an easy-to-read description of astronomical objects.
- Astronomy One* by J. Allen Hynek and Necia H. Apfel, W. A. Benjamin, Inc. (Menlo Park, Calif.), 1972—a pleasant introduction to the architecture of the universe; for the serious student.
- Atoms and Astronomy* by Paul A. Blanchard. (Available from the U.S. Government Printing Office, Washington, D.C. 20402), 1976—atomic spectra explained in simple terms and used to analyze the spectra of stars.
- Atoms, Man, and the Universe: The Long Chain of Complications* by Hannes Alfvén, W. H. Freeman & Co., Inc. (San Francisco), 1969—a dramatic explanation of what we see in telescopes.
- The Birth and Death of the Sun* by George Gamow, Viking Press, Inc. (New York), 1952—in simple terms, the master of science writing explains how stars shine and where they come from.
- Chemistry Between the Stars* by Richard H. Gammon (Available from the U.S. Government Printing Office, Washington, D.C. 20402), 1976—a basic discussion of gas clouds between the stars and their composition and physical conditions.
- Extragalactic Astronomy: The Universe Beyond Our Galaxy* by Kenneth Charles Jacobs (Available from the U.S. Government Printing Office, Washington, D.C. 20402), 1976—includes a simple description of our own Milky Way Galaxy and discussions of other galaxies, Doppler shift, cosmology, and related topics.
- Matter, Earth, and Sky* by George Gamow, Prentice-Hall, Inc. (New York), 1965—a well-illustrated survey of matter and radiation in space.
- New Frontiers in Astronomy* (readings from *Scientific American* with an introduction by Owen Gingerich), W. H. Freeman & Co., Inc. (San Francisco), 1975—contains articles on x-ray stars and searches for Black Holes.
- Rendezvous in Space: Apollo-Soyuz* by F. Dennis Williams (Available without charge from NASA Educational Programs Division/FE, Washington, D.C. 20546), 1975—a popular account of the Apollo-Soyuz Test Project, including the U.S.-U.S.S.R. agreements.
- Space Science and Astronomy: Escape From Earth*, Thornton Page and Lou Williams Page, eds., Macmillan Publishing Co., Inc. (New York), 1976—contains articles on almost every phase of spaceflight. See Chapter 9, “X-Ray and Gamma-Ray Astronomy.”

- Starlight: What It Tells About the Stars*, Thornton Page and Lou Williams Page, eds., Macmillan Publishing Co., Inc. (New York), 1967—see Chapter 3, “Stellar Spectra: The Analysis of Starlight.”
- Stars and Clouds of the Milky Way*, Thornton Page and Lou Williams Page, eds., Macmillan Publishing Co., Inc. (New York), 1968—describes the structure and motion of our Galaxy.
- The Story of Astronomy* by Patrick Moore, Macdonald and Co. (London), 1972—descriptive astronomy from early times to recent discoveries.
- The Supernova: A Stellar Spectacle* by W. C. Straka (Available from the U.S. Government Printing Office, Washington, D.C. 20402), 1976—a well-illustrated and dramatic account of how some stars blow up, leaving a halo of gaseous remnants in the space around them.
- X-Rays and Gamma Rays* by Daniel S. Halacy, Holiday House, Inc. (New York), 1969—a small, well-illustrated book with many interesting facts on radiation damage.

EP-134

NASA

National Aeronautics and
Space Administration