

77-55

SAFELY EVACUATING COAL FROM HOPPERS/  
SILOS WITH PNEUMATIC BLASTING

J. S. Fischer  
Martin Engineering Co.  
Neponset, Illinois

## ABSTRACT

For years the industry has coped with the problems of evacuating coal and other difficult bulk solids from storage containers. Many methods have been used to manage the problems; manual hammering, vibration, air lances, and vibratory hopper bottoms, to mention a few. Also, mass flow design in storage containers has been an approach to solving the problem. The latter often results in drastically reduced storage capacity and extremely expensive construction. The former methods also present inherent disadvantages of being inefficient, noisy, or expensive to install and operate.

After more than 30 years of being involved in the design and production of flow aid devices, a U.S. manufacturing concern recognized industry's need for an efficient, economical, effective and quiet device for moving coal and other difficult bulk solids. Thus came the advent of the low pressure pneumatic blasting system - a very efficient means of using a small amount of plant air (up to 125 PSI) to eliminate the most troublesome material hang-ups in storage containers. This simple device has one moving part and uses approximately 3% of the air consumed by a pneumatic vibrator on the same job.

The principle of operation is very simple: air stored in the unit's reservoir is expelled directly into the material via a patented quick release valve. The number, size, and placement of the blaster units on the storage vessel is determined by a series of tests to ascertain flowability of the problem material. These tests in conjunction with the hopper or silo configuration determine specification of a low pressure pneumatic blasting system.

This concept has often proven effective in solving flow problems when all other means have failed. A number of case histories in the area of coal handling will be cited where low pressure pneumatic blasting systems have completely solved troublesome flow problems. Further, we will analyze the benefits in each case, including increase in production efficiency and cost savings.

EVACUATION OF COAL FROM HOPPERS/SILOS  
WITH LOW PRESSURE PNEUMATIC BLASTING SYSTEMS

by

John S. Fischer  
Martin Engineering Company  
Neponset, Illinois

Evacuation of difficult or cohesive bulk particulates from containers has been a very costly problem. It is costly for numerous reasons: production downtime, manual labor to free material blockage, and use of inefficient and costly flow aid devices. Noise emission from certain flow aid devices and physical harm to workers due to numerous injuries, and in some cases, fatalities related to moving stored particulates occur annually, making safety a primary concern of industry today. The pneumatic blasting system alleviates these problems which plague industry since it is a fail safe system of moving the toughest bulk particulates.

Numerous manufacturers have designed and sold many types of flow aid devices. Yet, the vast majority have inherent disadvantages - vibratory hopper bottoms are expensive, and vibrators are relatively inefficient and/or noisy. Several years ago the concept of low pressure pneumatic blasting evolved. The merits of pneumatic blasting include totally unique capabilities such as economy, efficiency, effectiveness, and it is very quiet; thus, safe from a standpoint of preventing loss of hearing due to excessive noise. Technical aspects of the principle of operation will be illustrated and thoroughly explained.

The speaker will present several case histories illustrating a few of the many applications of pneumatic blasting, its truly unique capabilities, and the

degree of its success in solving the flow problem.

The safe and practical concept of pneumatic blasting has been proven and is already well accepted by many industries, though available to American industry for only a few years. In a short period of time, much has been learned in design and application of this concept. As with many truly new ideas, pneumatic blasting was welcomed by many and criticized by an element upon its introduction.

Much of the original theory in developing pneumatic blasting has proven factual; as with most new concepts, some theory has not. We are all in the learning process with regard to pneumatic blasting. Though most of this presentation is based on fact, we cannot ignore theory which must constantly be explored to allow the development of any concept including this revolutionary approach.

Compressed air has long been known as a source of power for many tools and machines, including devices for moving bulk solids. Examples are the piston type vibrator of years ago, and more recently, sophisticated pneumatic vibrators such as the motor driven rotary eccentric type.

Many industrial personnel involved in bulk materials handling are also familiar with direct air application methods of evacuating difficult material, such as the air lance and continuous flow air pads. Several flow aid devices are relatively sophisticated and somewhat more efficient than others. However, all display disadvantages - either noise, structural fatigue or inefficiency, and all consume a relatively high volume of compressed air. This rate of air consumption varies in degrees from tolerable to totally unacceptable by most standards. For instance, air lances will consume 60 to 100 cu.ft. of air per minute. At today's compressed air costs of 12-18¢ per 1000 cu.ft., such usage levels can become prohibitive.

As previously mentioned, another primary safety consideration today is the fact that noise problems exist. Controlling noise at the source is regarded by the Dept. of Labor for OSHA standards as the ideal means of preventing noise induced hearing loss. Realizing that most industrial vibrators could be detrimental to hearing, it became quite obvious that alternate methods of promoting flow of particulate solids had to be found. Pneumatic blasting systems proved to solve the noise problem by preventing noise at the source which is much better than limiting exposure of personnel to excessive noise.

So the problem with conventional flow aids was twofold; noise control and the high cost of operating conventional flow aid devices. This situation brought about the advent of a material-moving pneumatic air cannon. The new concept proved to be a solution to industry's dilemma since pneumatic blasting is effective, yet quiet and economical.

This breakthrough occurred in the past three years. It is the product of several years of long, laborious and costly research and development, but it has been well worth it.

Unlike vibration devices, the pneumatic blaster does not move materials exclusively through the reduction of friction. The pneumatic blaster shocks the mass of cohesive material, fracturing it and causing free flow, whether it be bulk solids sticking to the walls of a hopper, silo, chute, or building up under screens, and even flow problems in stockpile storage. While alleviating the noise and cost of operation problems, pneumatic blasters have also proven effective with material-moving problems no other devices could handle. An example of this type of application will be discussed.

In order to pursue discussion regarding pneumatic blasting, we should review

commonly accepted terminology:

slope angle - downward angle of slope measured in degrees from horizontal.

archability - the tendency of a cohesive powdered or granular solid to form an arch or bridge in the hopper or silo.

rathole - the result of material collecting on the wall of the storage container, leaving a hollow core in the center of the storage container

compressibility - a value arrived at by taking the difference between the aerated bulk density and the packed bulk density, and dividing this difference by the packed bulk density.

working bulk density - the working bulk density will equal the packed bulk density, minus the loose bulk density, times the compressibility. This value is added to loose bulk density and equals working bulk density.

angle of repose - the angle between the horizontal and the slope of a heap of material dropped from a specified elevation. For our purposes, it can be defined as the constant angle to the horizontal, assumed by a cone like pile of material.

angle of fall - the angle of repose resulting from a jarring effect.

angle of difference - the value arrived at by noting the difference between angle of repose and the angle of fall.

dispersibility - the direct measure of the ability of a material to flood or be fluidized.

cohesion and uniformity - cohesion and the uniformity coefficient are alternate flow properties used in the flow evaluation. Cohesion is used with powders and very fine particles, or with materials on which an effective cohesion force can be measured. The uniformity coefficient is used for granular and powdered granular materials in which an effective surface cohesion cannot be measured.

surface area - the surface area of a given particle.

hygroscopicity - the tendency of a solid to pick up moisture on its surface from the ambient atmosphere; to "cake up".

Efficiency of the pneumatic blasting device is relative to a number of factors. First, the degree of free air flow from the device directly affects the force output of the unit as well as velocity of the air escaping. The objective in design is to achieve the optimum degree of velocity and force with minimum air pressure, and in most cases, minimal volume. In simple terms, the most efficient design will allow a given volume of air at a given pressure to be released in the least amount of time. An extremely efficient design - to our knowledge, the most efficient design - appears in Figure I. This design provides optimum efficiency since the distance of reservoir opening to discharge opening is a minimal distance of approximately 8". Thus, the air flow meets very little resistance, allowing maximum force and velocity output.

Secondly, the air passageway is obstruction free upon activating the unique patented piston poppet valve. This latter feature significantly increases force and output in comparison to other designs.

The principle of operation is very simple. Air enters the blaster via a quick exhaust valve. Air enters chamber (A) and compression causes the piston (B) to move forward and seat on (C) and air flows through orifice in center of piston, filling chamber (D). To discharge the blaster, the quick exhaust valve is activated, releasing air in chamber (A) which allows pressure from chamber (D) to force piston back into air space (A). Air in reservoir (D) is expelled through the discharge tube.

This most recent design also affords infinite flexibility in reservoir size

since the valve is external and bolted to the tank. Thus, non-standard ASME code welded reservoir tanks are readily available to meet the user's specific needs.

The quick release valve is activated by any number of control systems, each providing features for various applications: manual pneumatic (Figure II), manual electric (Figure III), or timed electric (Figure IV). The latter two control systems implement solenoid valves to actuate the blaster system. For a completely automatic system, the "timed electric" system is ideal. The entire system can be actuated through a relay connection sensitive to an open gate, operating feeder, or conveyor. In this case, the "timed electric" controls operate the blaster system only upon demand of material.

The more versatile "timed electric" control system is emphasized since it eliminates human error and manual labor; also, the "pneumatic blasting" concept is dependent upon a system installation. Oftentimes, a system installation will require multiple units at various levels on a storage container. With many bulk solids, it is imperative to actuate the units separately or actuate levels of blasters individually. Usually, it is necessary to first evacuate the bulk solids in lower slope section of a container (close to discharge). This is accomplished by firing the first level blaster(s) (Figure V). Once the lower portion of the slope is free of stubborn material, the solids in the upper portion of the container may be broken up into a free-flowing stage (Figure VI) and immediately evacuated through the discharge. Most often, as the density and cohesion factors of material increase, it is necessary to fire the blaster units separately. Conversely, as material density and cohesion decreases, so does the need to actuate blasters separately. Note: This statement is only a "rule of thumb".

Another advantage of "timed electric" is the safety factor. For instance,



not only is there limited and efficient usage of the system since it operates only on material demand, but when the system operates, certain precautions can be taken as provided automatically. For instance, when the system is actuated, a hatch on top of container can be automatically locked, a beeper or siren actuated with or without a flashing light so personnel are aware.

Specification of a system involves numerous variables. With respect to the flow characteristics of bulk solids, we must consider the following properties: particle size, surface area, specific gravity, working bulk density, hygroscopicity, moisture content, angles of flow, adhesion, cohesion, and compressibility. Various combinations of these properties measure basic flow characteristics or flowability of any given bulk solid. Our concern is with non-free flow or stubborn solids which require flow aids; thus we confine discussion to these properties.

Massing or caking of materials may be substantially reduced or eliminated through (1) a modified container design, or (2) a flow aid device or sometimes additives mixed with the material. All have their advantages and disadvantages. A common problem in solving the flow problem through container design is keeping the overlying material weight at a minimum, yet having a slope angle allowing the material to flow. Generally speaking, mass flow container design for a very stubborn material results in comparatively low storage capacity at a considerable expense. A problem may often be solved at much less expense with an effective and efficient flow aid device and standard container design.

When specifying a pneumatic blasting system, we determine the specific variables or properties which affect the flowability of the problem bulk solid. First, it is necessary to determine whether the troublesome bulk solid is powder or granular. For our purposes, the minus 200 mesh size will be powder; plus 200 mesh

size granular. This simplifies specification of a system. Determining whether a material is granular or powder narrows the range of specific properties to consider in determining flowability of the bulk solid. The four absolute properties which will determine the flowability of a powder are: (1) angle of difference, (2) angle of fall, (3) dispersibility, and (4) cohesion. In analyzing the flowability of a granular bulk solid, one needs to consider (1) working bulk density, and (2) surface area of particle.

For the practical discussion of specifying a blaster system, the flow characteristics of the bulk solids must be considered in conjunction with, and equally important, storage vessel size and configuration. It is obvious that the slope angle of a hopper bottom would have a direct bearing on the ability of a given material to evacuate from a hopper/silo, etc.

In summary, sizing, placement, and firing sequence of a blaster system is specified in consideration of the bulk solids flowability, which is contingent on two basic factors: the select properties of the solid and on container size and configuration . . plus, working experience with these systems is very important in specifying a system.

The select properties affecting flowability of a powder or granular substance must be considered absolute, yet one must always be aware of extraneous factors which are not absolute or always existing in a bulk solid. For example, hygroscopicity, moisture content, shape rugosity, temperature, and so on.

Next, what is the real theory behind low pressure pneumatic blasting? Speaking of the design in Figure I, the volume of air is released in approximately .25 sec. at a velocity of 1,198 ft. per sec. at 90 PSI. Assuming the material build-up is

relatively thick and the solid is of typical density (45 to 100 lbs/cu.ft.), the blast of air upon discharge will act as an expanding air pocket, expanding parallel with the wall of the structure, pushing outward at the same time, and ultimately displacing a section of the bulk solid from the wall. Essentially, it is breaking the shear strength of the hung-up or clinging material. As the depth of material build-up and/or density decreases, so does the effective radius of the expelled blast, to an extent (rule of thumb).

It is possible to blast a relatively small hole in the material build-up. When material build-up is not extremely thick and/or dense, the use of directional discharge accessories is necessary. Three basic types of directional accessories are most commonly used: 45 degree el, 90 degree el, or a narrow slotted nozzle directs the blast parallel to the container wall instead of perpendicular and directly into the material.

The pneumatic air cannon can be applied to storage vessels made of concrete, wood, or steel. Also, with pneumatic blasting devices it is possible to pipe the discharge through an extension to remote or inaccessible (exterior) areas within the structure. There are numerous structures where pneumatic blasters are virtually the only flow aid which could perform effectively. One of many such installations exists at a large grain terminal handling soybean meal. The storage facility consists of clustered concrete silos, 30' dia., 90' high, with a cone of 30 degrees off horizontal center. This company intended to keep the meal in storage for up to 6 weeks. Unfortunately, upon opening the discharge gate, most often very little or virtually no material would flow. Consequently, the operator was forced to resort to manual labor - poking and prodding the material free. This can be very dangerous since materials are capable of flooding. The cost of the problem was extremely high for two reasons: manual labor costs, and the production (in this case, transfer) downtime.

This arching problem is typical of soybean meal, yet three factors made this particular problem far worse than what typically exists. A 30 degree slope (off horizontal) is not at all common: most silos are designed with a 45 degree to 70 degree slope. Secondly, as the protein content of soybean meal increases, its flowability decreases. Average soybean meal contains 44% protein; the meal in this particular silo contained 50% protein. Lastly, the clustered silos had only 120 degrees of exposed exterior wall. This proved to compound the problem since it is very important to blast within 18" above or below the intersection of the cone and vertical wall.

This terminal finally found the solution to be a pneumatic blasting system. The flow aid manufacturer decided to tackle this problem with a unique system. Since the manufacturer had already equipped numerous soybean meal silos all over the United States with very successful and cost saving pneumatic blaster systems, the number of blasters and placement of discharge was not difficult to determine. Again, it is very important to blast in two areas or levels; first, in the slope portion, and a second level within 18" above or below the intersection of cone (or slope sheet) and vertical wall (Figure VIII). This placement and location of units in two levels is found to be most effective on round vessels containing materials which display archability characteristics. The system specified called for three low volume blasters to be mounted on the exposed exterior wall, approximately 40 degrees apart, and 18" above the intersection of cone and vertical wall (FIG.IX) To reach the remaining interior circumference at this junction which is most critical (in this case, inaccessible from the exterior), it was necessary to mount four higher volume units on the uppermost section of the cone. Each of these four units have a discharge extension parallel to the interior wall of the cone, extending 18" above the intersection of the cone and vertical wall (Figure X) with a total length of approximately 12'. Thus the first phase of installation involved

seven blasters, discharges equally spaced 51 degrees apart, 18" above intersection of the cone and vertical wall.

The second phase was very simple, involving the installation of three low volume blaster units, equally spaced 120 degrees apart, 6' up from the discharge on the cone (Figure VIII & IX). The system was put to the ultimate test on 50% protein meal which was left in storage for approximately 8 weeks. Upon twice firing the lower level of blasters, the cone portion was free of material. Next, the upper level of units was fired, freeing the cohesive mass with ease. Upon completely evacuating the structure, the operator was pleased to find 95% of the troublesome material had been removed. To our knowledge, no other flow aid could have been installed. Regardless, it is extremely doubtful that any other conventional flow aid is even capable of evacuating bridged soybean meal from a large storage vessel under any circumstances, and many have been tried.

In the past two years, virtually hundreds of successful pneumatic blasting systems have been installed in numerous industries. To mention a few: wood products, food, chemicals, ores, and plastics (Figure 11). Furthermore, the system has been proven effective in moving the most stubborn materials through a wide range of cohesiveness and density. For instance, wood chips at 20 lbs. per cu.ft. (with an extremely high entanglement factor), through very cohesive ore concentrate at 180 lbs. per cu.ft. It is known that blaster systems have worked effectively in promoting flow of at least over 100 different materials of various consistencies.

Finally a proven system has evolved which allows plants to safely move bulk particulates from storage. No longer is it necessary for men to be exposed to

noisy vibrators. Never again should it be necessary for personnel to poke or prod materials out of a container from the top or discharge, or crawl inside a container full of potentially dynamic material. Incidentally, the last two methods have attributed to many deaths and even more injuries, worldwide. Now there's an answer.

In summary, these advantages may be attributed to pneumatic blasting:

1. Minimal air consumption - approximately 3 $\frac{1}{2}$  as much as a pneumatic vibrator.
2. No noise - noise is contained in storage vessel as well as absorbed by the bulk solid.
3. No structural reinforcement or fatigue.
4. Simple - one moving part, no electric motor, shaft, vanes, etc.
5. Ease in mounting - simply cut hole of prescribed diameter (up to 5" dia.), bolt mount plate to concrete, wood or steel structure. No major alteration to existing new structures.
6. No lubrication or filtration.
7. No sparks or flames.

PARTIAL LIST OF MORE COMMON MATERIALS TO WHICH THE BIG BLASTER AIR CANNON HAS BEEN APPLIED (Figure XI)

Potash	Hay (chopped)
Compacted garbage	Molasses (chopped)
Prepared foundry sand	Sorghum (chopped)
Limestone (powdered)	Copper ore (fine & coarse)
Rice hulls	Copper concentrate
Triple super phosphate	Wood chips
Gypsum (coarse) (dust)	Sawdust
Coffee	Wood bark
Coal	Crackling
Clay (200 mesh)	Nickel ore
Polyester floc	Sugar
Diatomaceous earth	Poultry feed (pellets)
PVC powder	Horse feed (pellets)
Calcite (moist)	Salt (granulated) (rock)
Soybean meal	Filler cake (for animal feed)
Chlorinated trisodium phosphate	Flue dust
Cement	Wheat flour
Meat meal	Iron ore
Bran	Oat flour
Cake flour	Refractory (powder)
Alumina	Foam (ground)
Wheat middlings	Calcium carbonate
Plastic chips	Ammonium hydroxide
Lead concentrate	Paper (shredded)
STP-2	

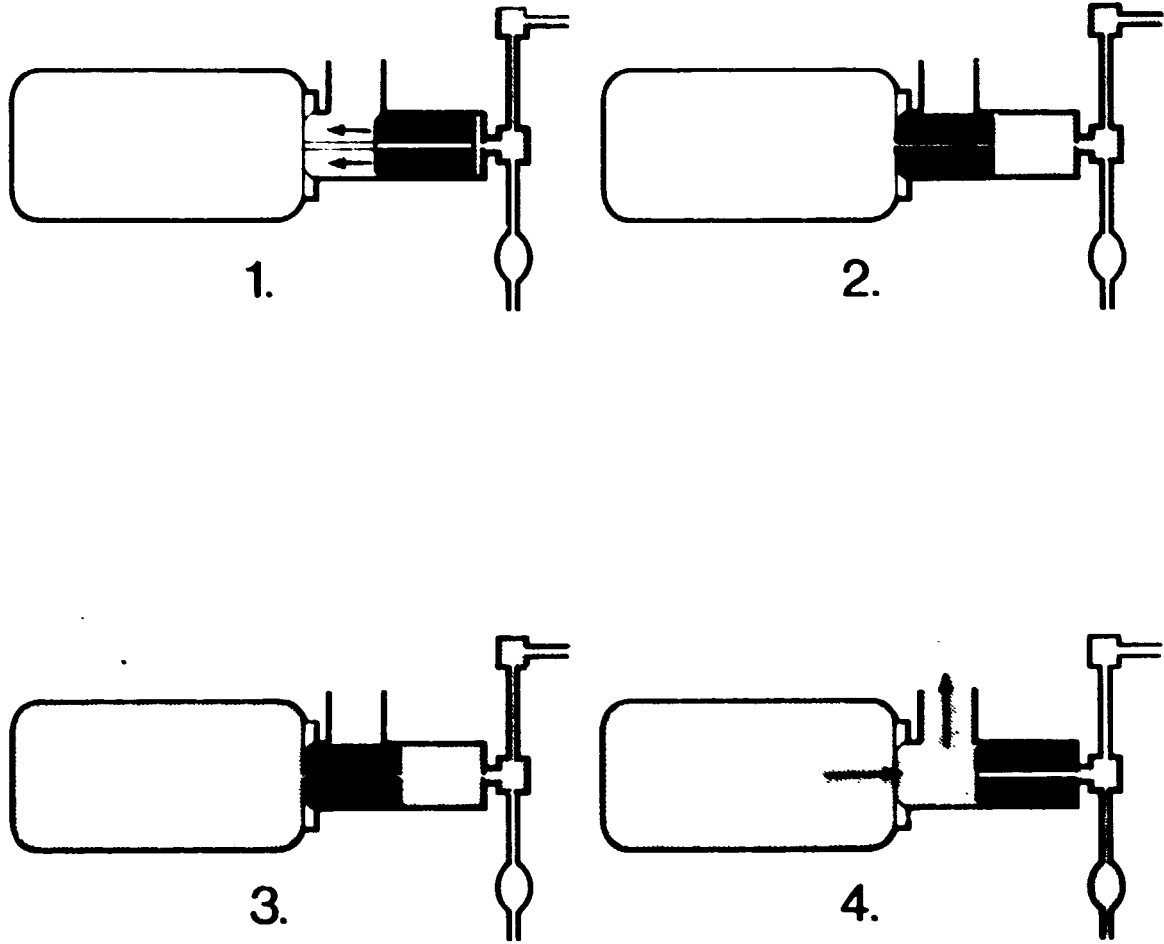

That's all there is to it!

FIGURE I



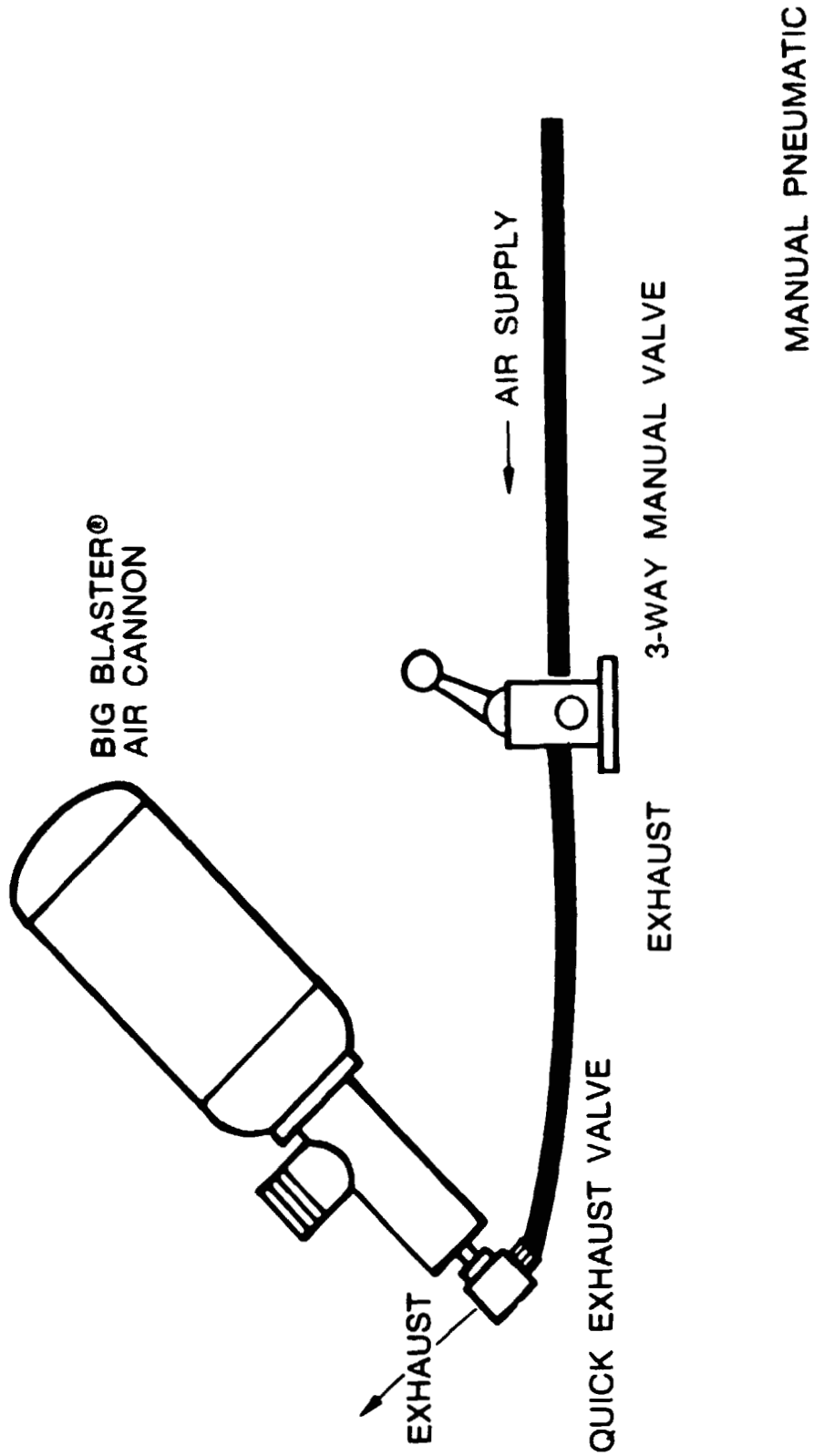
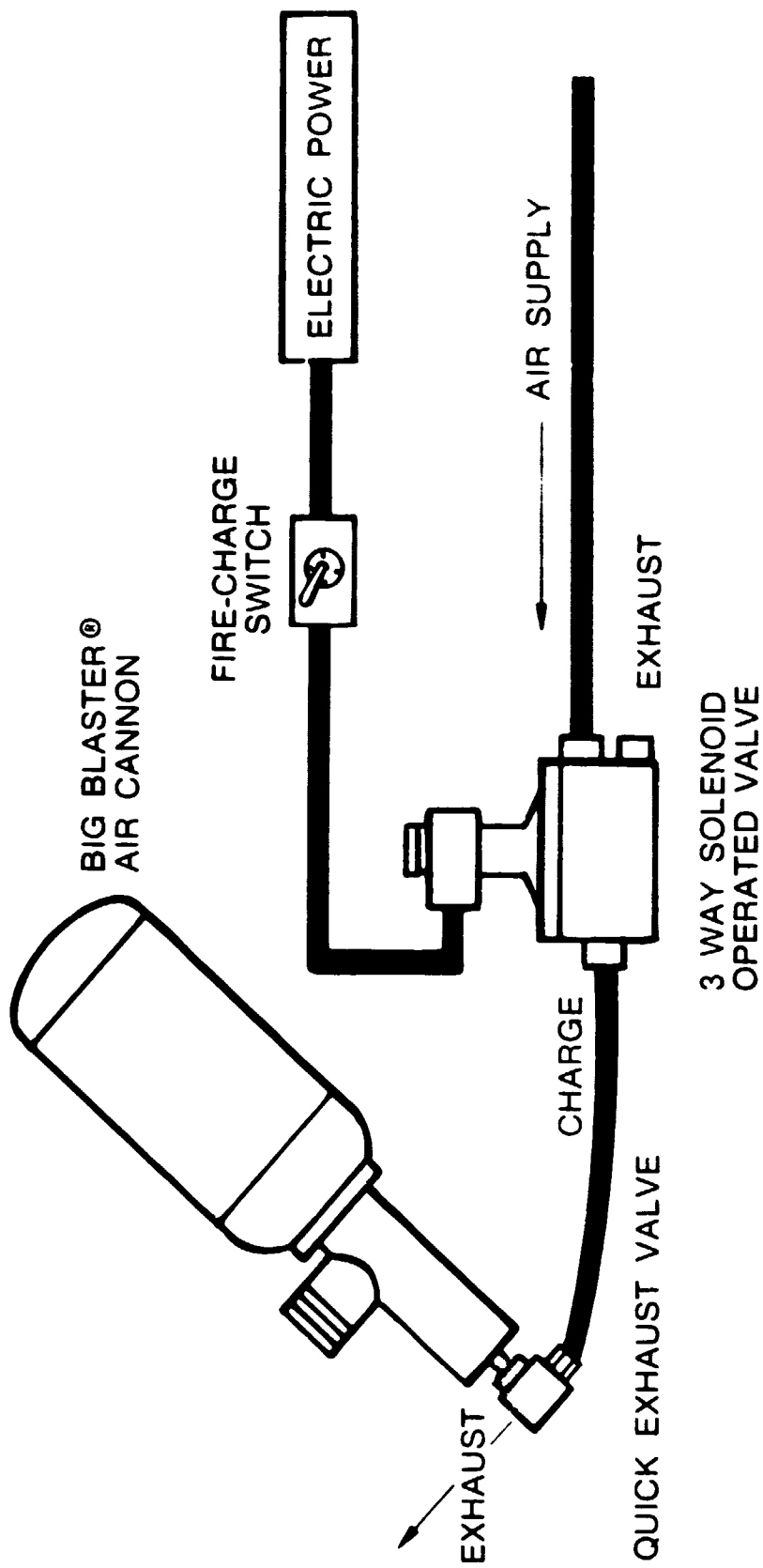

FIGURE 11



BIG BLASTER®  
AIR CANNON

FIRE-CHARGE  
SWITCH

ELECTRIC POWER

AIR SUPPLY

EXHAUST

3 WAY SOLENOID  
OPERATED VALVE

CHARGE

EXHAUST

QUICK EXHAUST VALVE

MANUAL ELECTRIC

FIGURE III

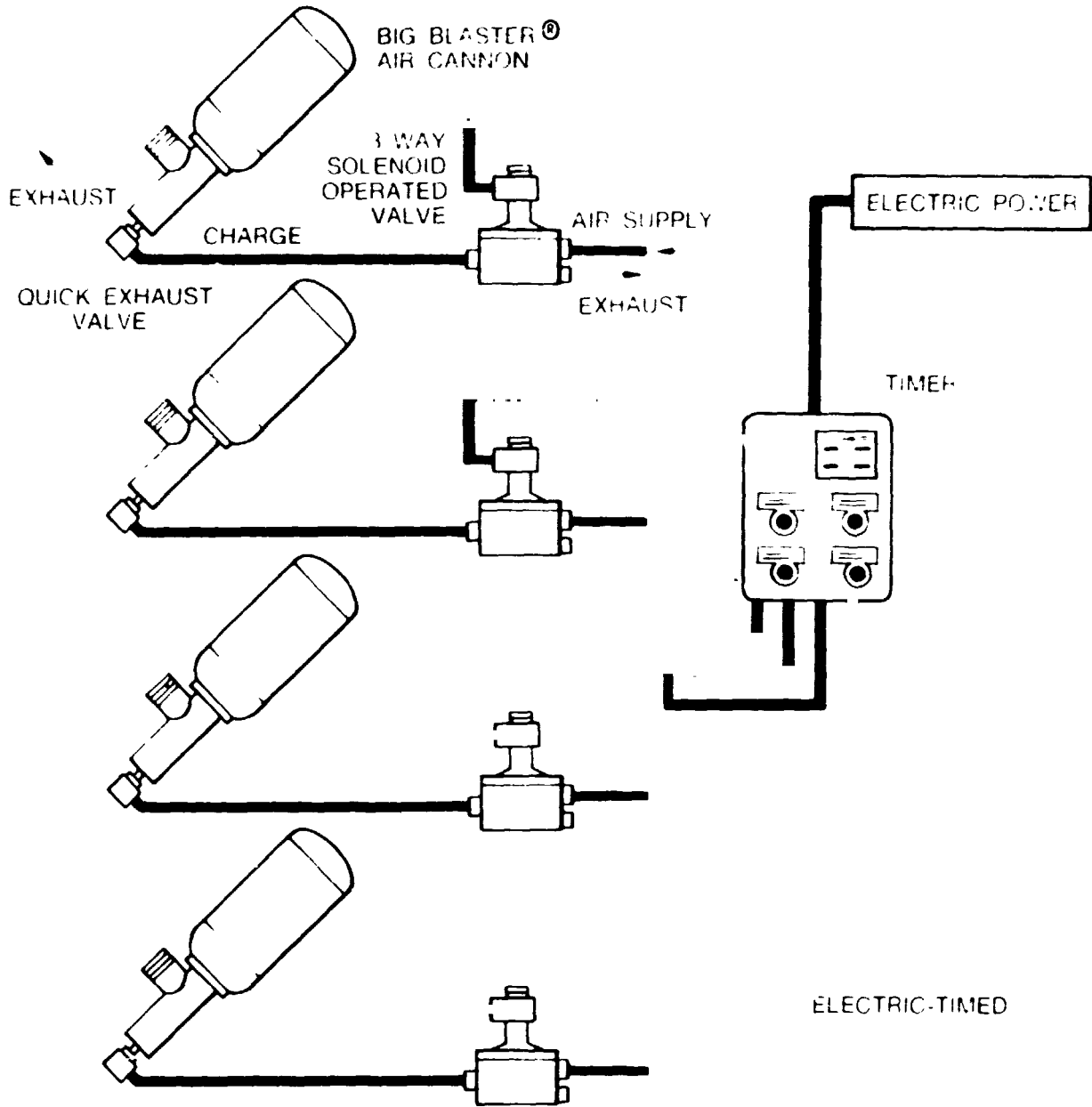

FIGURE IV

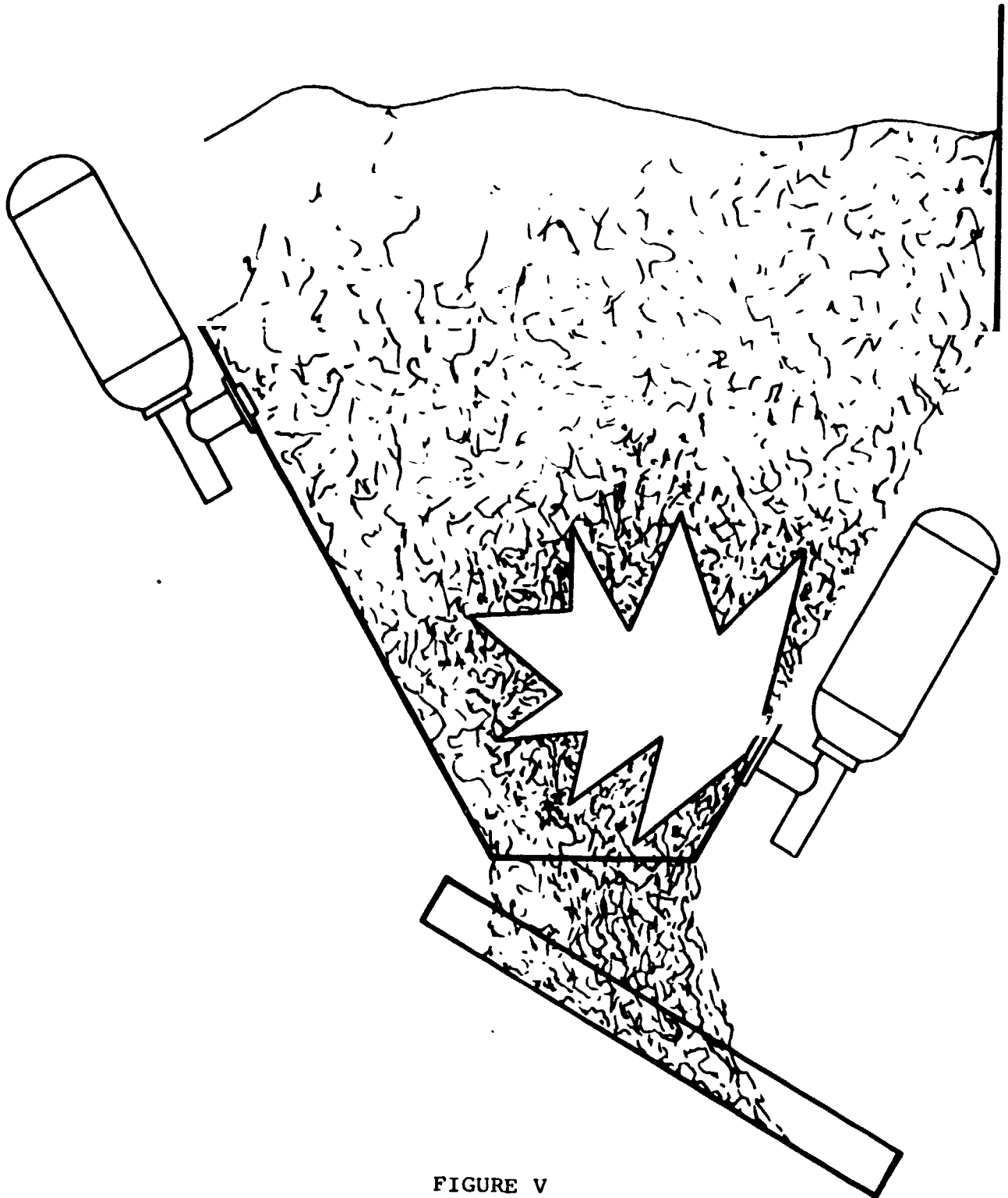

FIGURE V

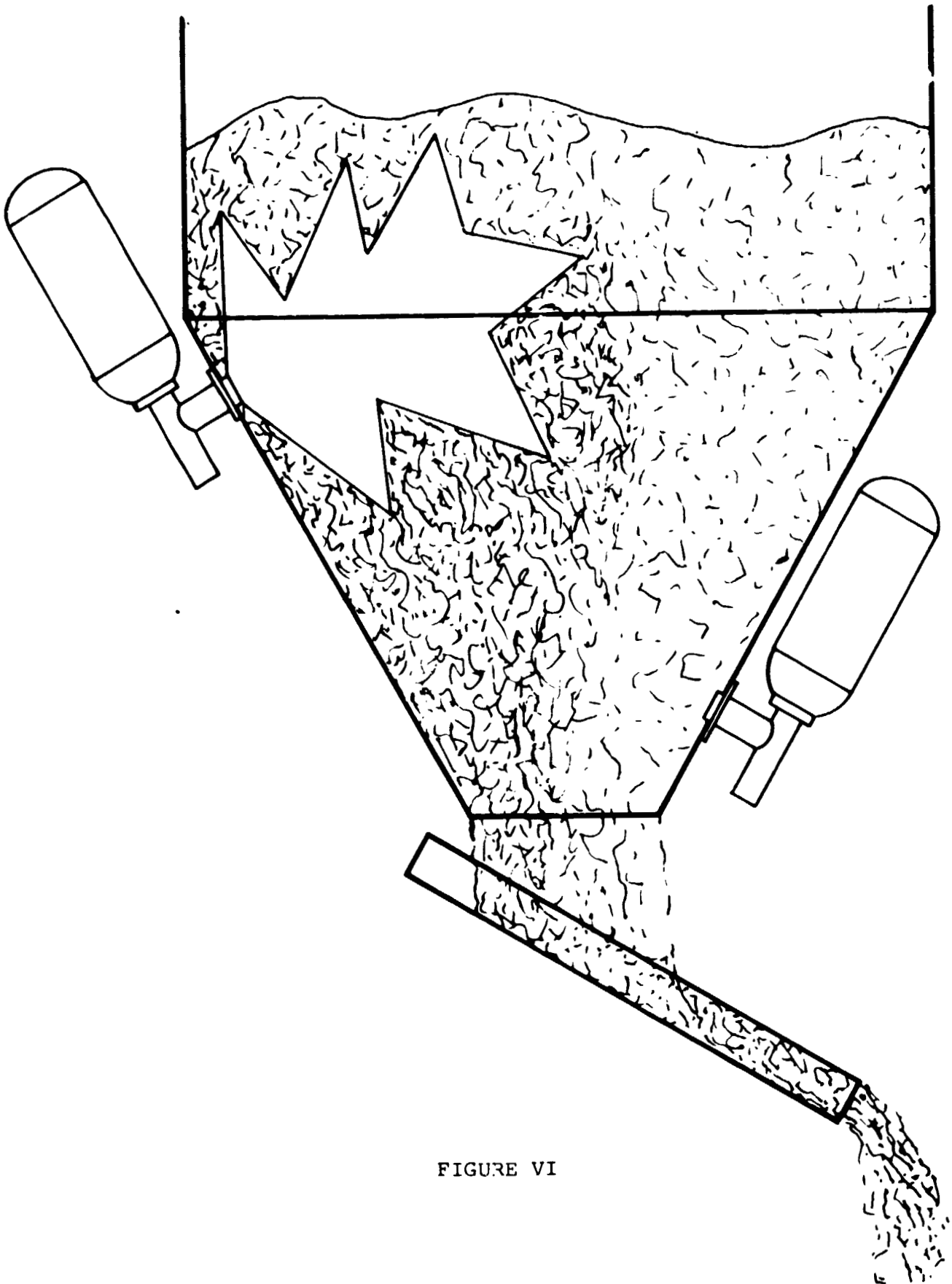

FIGURE VI

77-55

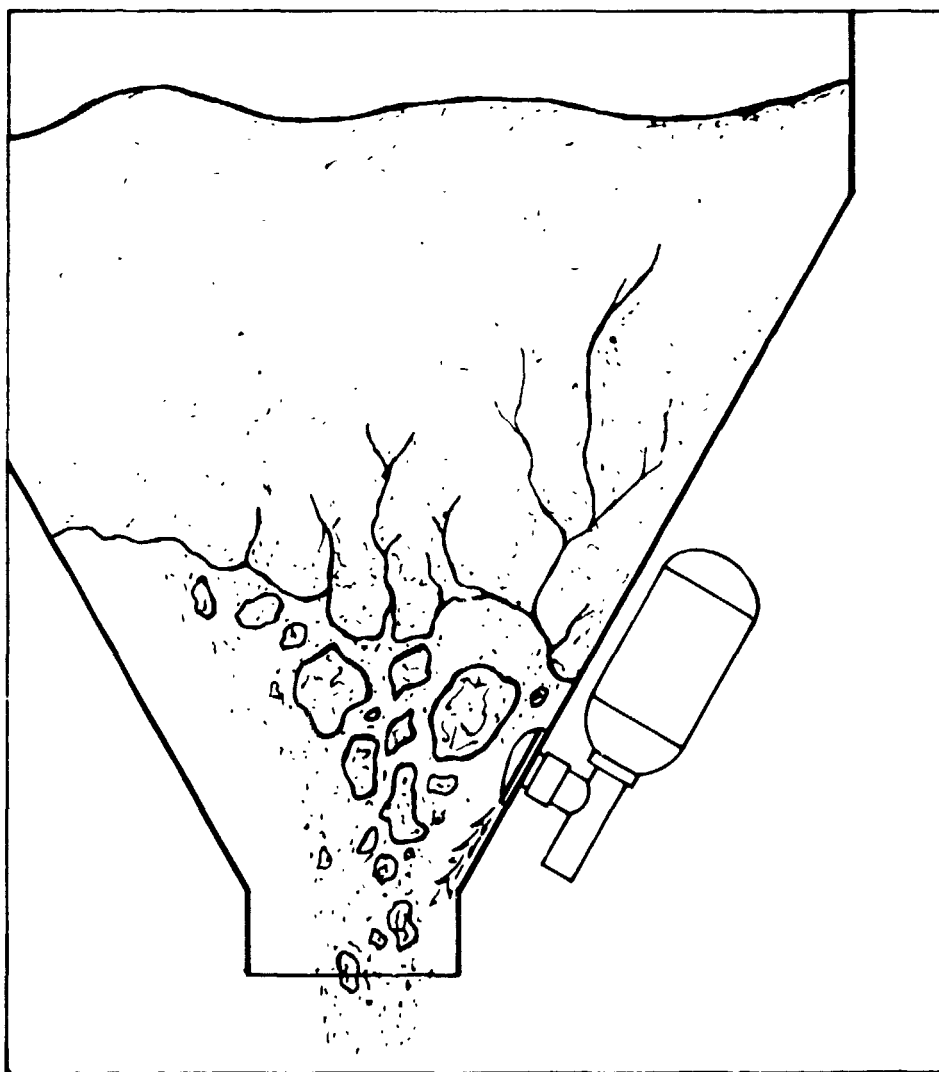
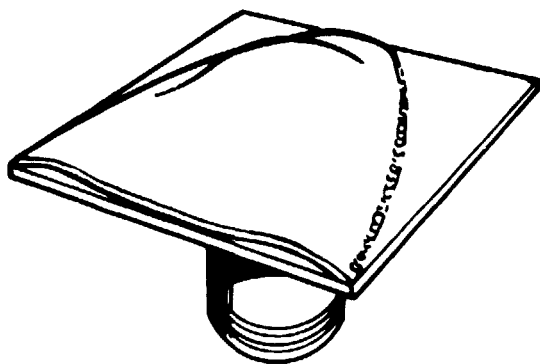

FIGURE VII

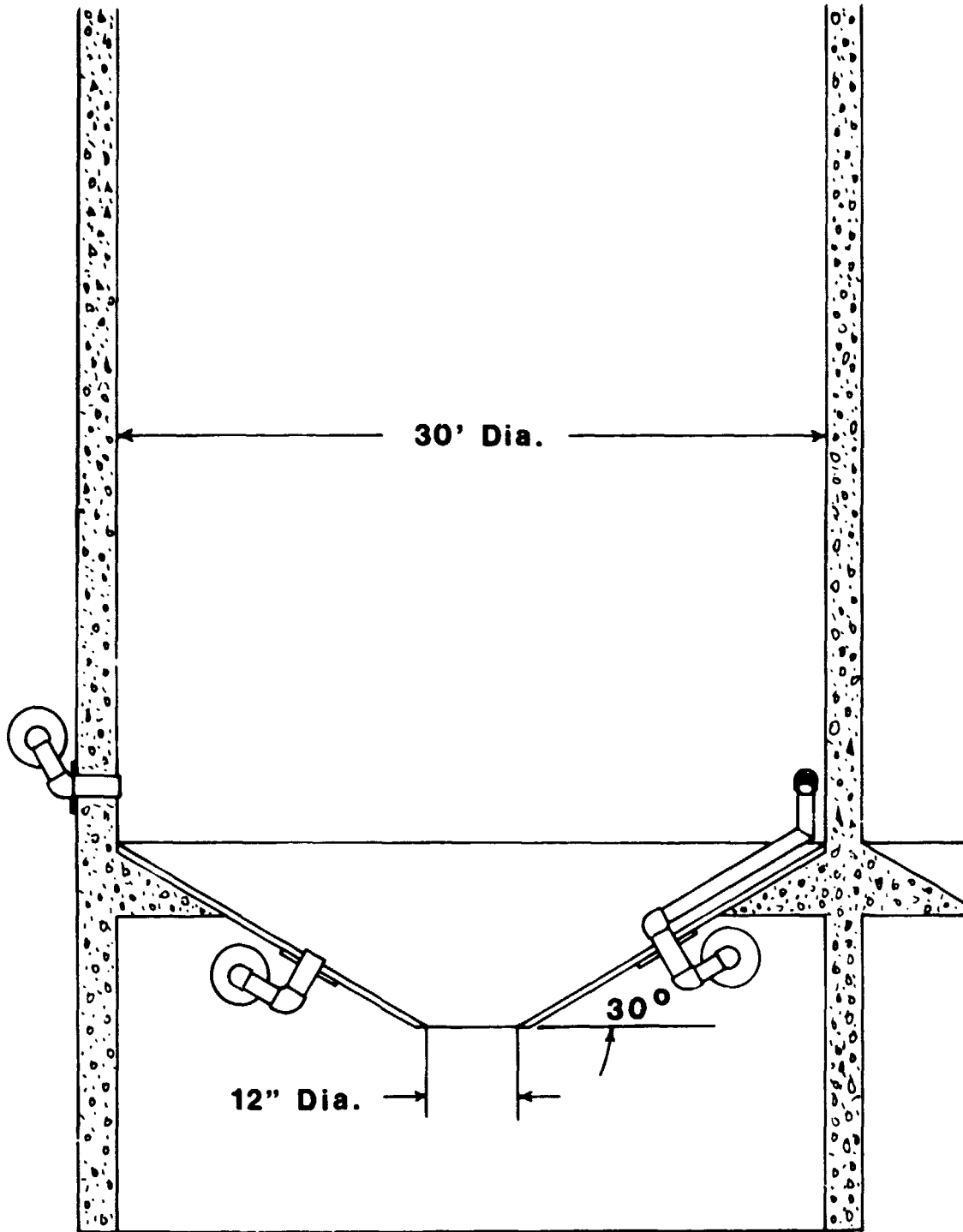

FIGURE VIII

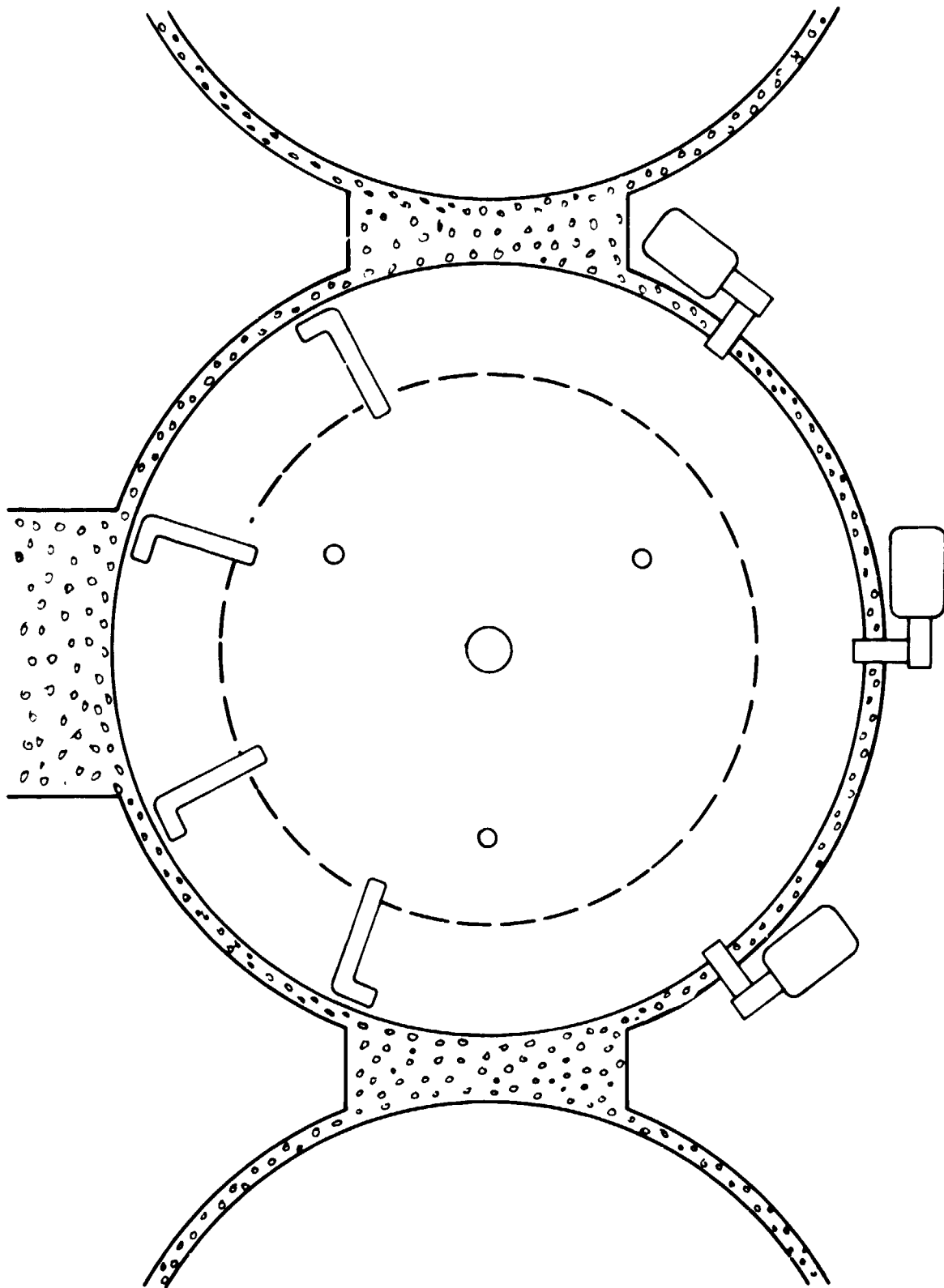

FIGURE IX



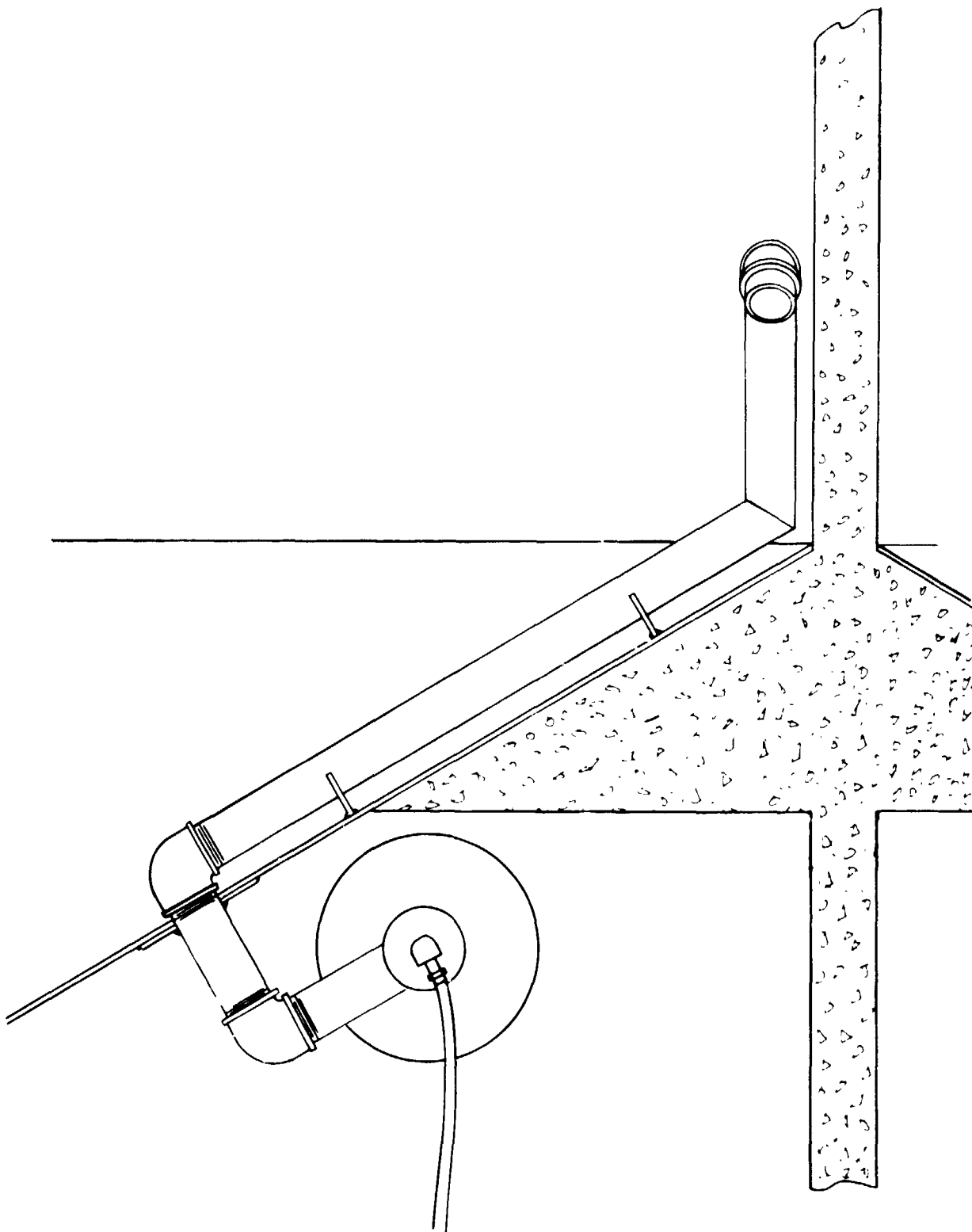

FIGURE X