

015

77-55

N78-13256

COAL EXTRUSION IN THE PLASTIC STATE

C. England

P. R. Ryason

Jet Propulsion Laboratory
Pasadena, California

Coal Extrusion in the Plastic State

C. England and P. R. Ryason

ABSTRACT

Continuous feeding of coal in a compressing screw extruder is described as a method of introducing coal into pressurized systems. The method utilizes the property of many bituminous coals of softening at temperatures from 350 to 425°C. Coal is then fed much in the manner of common thermoplastics using screw extruders. Data on the viscosity and extruder parameters for extrusion of Illinois No. 6 coal is presented.

Introduction

This paper describes work on the feeding of coal to pressurized systems utilizing the properties of many coals to become semi-fluid under the action of heat and pressure. Experimental work has centered on modified thermoplastic extruders utilizing a single screw design in which bituminous coals enter as a granular solid and exit as a viscous fluid at elevated pressure.

The technique is based on the property of most bituminous coals to go semi-fluid or "plastic" at temperatures near 400°C and at modest pressure. Most of the previous interest in these properties has been related to the production of coke for metallurgical purposes where selection of coals for blending is made partially on the basis of measurements of plasticity. Tests such as ASTM D-1612-69, utilizing the Giessler plastometer, have been developed for this purpose.

Coals can be rendered plastic at high pressure by devices common to the technology of the processing of thermoplastics.⁽¹⁾ One of the simplest of these devices is the screw extruder, shown schematically in Figure 1, in which the material to be extruded is heated and compressed until the desired outlet conditions are reached. The action of the compressing screw on the viscous material can cause very high pressure to occur in the extruder. Depending on the conditions such as flow rate and viscosity, pressures up to 35 MPa (5000 psi) can be obtained.

Measurement of Coal Viscosity

Of the many properties of coal that are of interest in extrusion, the most important are the viscous properties and their relation to temperature, shear and time. No data were available on the actual viscosity of coal, and an experimental program of capillary rheometry⁽²⁾ was undertaken to measure the viscosity of several

coals in their plastic range. A short capillary was used in these experiments; the apparatus is shown in Figure 2. Separate preliminary experiments showed (by means of a thermocouple embedded in coal in the die) that steady temperatures were reached in the coal in about seven minutes. On the die axis, coal temperatures were consistently lower than the indicated temperatures by about 2°C. To load the die with coal, it was first weighed, coal added, and die plus coal reweighed. As indicated in Figure 2, a close fitting graphite plug was used to seal the upper surface of the coal to retain volatiles. Apparent viscosities were determined as follows. A loaded die and piston were placed in the brass block, thermal contact established by melting solder in the annular gap between die and heater block, and seven minutes allowed to pass. The cross head of the Model IIC Instron testing machine with a compression cage was then set in motion, and plastic coal forced through the capillary of the die. Either constant force or constant shear rate conditions were employed. Force readings were directly obtained from the load cell on the Instron machine.

Shear rates ($\dot{\gamma}$) were computed from

$$\dot{\gamma} = \frac{4\dot{Q}}{\pi R^3} = \frac{4 R_d^2}{R^3} \frac{dl}{dt}$$

and shear stresses (τ) from

$$\tau = \frac{R\Delta P}{2L}$$

where \dot{Q} is the volumetric flow rate, R_d is the radius of the die, dl/dt is the cross head speed, R is the radius of the capillary, ΔP is the pressure across the capillary, and L is the capillary length. Apparent viscosities were then computed from

$$\eta_{app} = \frac{\tau}{\dot{\gamma}}$$

Measurements were made of apparent viscosity vs temperature and shear rate for Illinois No. 6, Orient No. 3 bituminous coal. The analysis of this coal is given in Table 1. Figure 3 shows the apparent viscosity as a function of temperature with the residence time and shear rate fixed. As one would expect, the coal softened upon approaching the plastic region, then hardened at temperature associated with the coking properties. These data were quite sensitive to residence-time effects; these effects are currently under study.

Figure 4 shows the apparent viscosity as a function of shear rate (essentially the mass flow rate through the capillary). The viscosity is a strong function of shear rate, and follows the power law relation⁽⁴⁾ in a manner similar to pseudoplastics. Thus, coal may behave much like a conventional plastic in the extruder. The absolute value of the viscosity varies widely under the different conditions of temperature, time, and shear rate, but are comparable in some range to conventional plastics.

Operation of the Screw Extruder

The plasticating screw extruder⁽²⁾ combines the steps of solids transport, melting, and pumping in one device, making it attractive as a feeder for coal in the plastic state by virtue of its simplicity. Solid coal is augered into the central parts of the extruder where it is heated, compressed, vapors expelled, and melting begun. Heating is both by conduction from the barrel and by mechanical working of the coal. When the coal becomes plastic, it is pumped by a drag flow mechanism in which the flow rate is determined approximately by the equation

$$\dot{Q} = aN - b \frac{\Delta P}{\mu} \quad (1)$$

where Q is the volumetric flow rate, N is the screw speed, ΔP is the pressure across the pumping portion of the screw, μ is the fluid viscosity, and a and β are constants related primarily to the geometry of the extruder. ⁽²⁾ Equation (1) indicates that flow decreases with increasing pressure and increases as the viscosity rises. Maximum flow occurs at zero pressure and maximum pressure occurs at zero flow.

The volumetric flow rate across the die is determined by the Poiseuille equation for the flow of fluids through cylindrical round tubes.

$$Q = \frac{D^4 \Delta P}{128 \mu L} = K \frac{\Delta P}{\mu} \quad (2)$$

From equations (1) and (2), the pressure is found to be ⁽²⁾

$$P = \frac{\mu a N}{(\rho + K)} \quad (3)$$

Thus, the pressure developed is proportional to the viscosity and the screw speed. These equations assume that the flow through the extruder is governed by the screw pumping, and neglect compression, melting and solid feed considerations. Each of these have major effects on actual extruder performance.

Screw extrusion of Illinois No. 6 coal was demonstrated with a commercial screw extruder which was previously used to extrude polyethylene. The 3.81 cm dia. extruder (Centerline Machinery Co., Santa Ana, CA) was of conventional design. Screw speed was continuously variable up to a maximum speed of 120 rpm. At any given speed setting, screw speed was constant. A 3.7 Kw (5 hp) DC motor turned the screw through a multiple "V" belt drive. The extruder barrel was conventional: $L/D = 22$, constructed of 4140 steel with an Xaloy liner spun cast in place, with a Vickers-Anderson type flange at the delivery end. The die was a 0.48 cm (0.189 in) bore capillary which was segmented to allow varying lengths of 2.5, 7.6, and 12.7 cm.

The screw was of conventional design with an overall length of 81 cm (31.9 in). The maximum channel depth in the feed section was 0.77 cm, and this section took up the first 40 cm of the screw. The last part consisted of a linear compression section which reduced the flow area by a factor of 2.5. No metering section was used. The end of the screw was conical in shape, allowing about 0.41 cm (0.162") clearance between the cone surface and the interior surface of the die. Additionally, a bar 0.32 cm (0.125" wide) was welded along the surface of the cone to act as a wiper, keeping coal in the die in motion as the screw turned. A clearance of about 0.051 mm (0.002") was maintained between the surface of the wiper and the interior surface of the die.

The barrel was preheated prior to feeding coal by means of electrical heaters clamped onto the barrel. Polyethylene beads were fed slowly into the extruder to help heat the screw. No other means of heating the screw was available. In addition, the coal was preheated to 200°C by electrically-heating the delivery tube of the Vibroscrew powder feeder which was used to meter the coal into the screw extruder. The Vibroscrew bin as well as the entrance port of the screw extruder were blanketed with CO₂ to prevent premature oxidation of the heated coal.

Extrusion of Illinois No. 6 coal was achieved for periods up to 50 minutes before shutdown occurred due to blocking of the die by pieces of coked material. Reliable measurements of the coal viscosity were not obtained from die pressure measurements, and considerable difficulty was experienced with coking, failure of the coal to melt completely, and solids feed problems related to volatilization and to caking phenomena. These problems occurred to a much lesser degree in previously extruded coals (see Ref. 1 on Mi'lburn and Kentucky coals). Rheometry measurements had indicated the potential of rapid coking with Illinois No. 6 coal. Indications of localized coking in the extruder resulting in irregular operation were also seen. These included slow plugging of the die and the production of chunks of coal within the extruder that were sufficiently large to temporarily block the die.

Preparation of the coal varied with the particular test. Most success was found when the coal was dried at 300°F, and sized to a 10/20 mesh. Generally, it appears the problems related to heat transfer and feed are reduced by continually removing fines. Such problems are in part related to the extruder design; it is possible that they are accentuated by the small size of the laboratory extruder.

Power requirements for extrusion of Illinois No. 5 coal varied widely with the particular test and temperature profile in the extruder. Sufficient runs were not made to determine an optimum temperature profile. Table 2 shows typical experimental results from Illinois No. 6, with the energy requirements varying from 68 to 108 kw-hr/ton. The power appears to be closely related to the detailed temperature profile in the screw, and these relationships will be the subject of further study.

References

1. P. R. Ryason and C. England, "A New Method of Feeding Coal," Fuel, in press.
2. J. M. McKelvey, Polymer Processing, John Wiley and Sons, Inc., New York (1962), pp. 288-290.
3. E. C. Berhardt (Ed.), Processing of Thermoplastic Materials, Reinhold, New York (1959), pp. 548, 549.
4. R. S. Lenk, Plastics Rheology, Wiley Interscience, New York (1968), pp. 29-34.

Table 1. Analysis of Illinois No. 6 (Orient No. 3) Coal

Proximate Analysis:

	<u>As Received</u>	<u>Dry Basis</u>
% Moisture	11.00	
Ash	8.28	9.30
Volatile	32.48	36.50
Fixed Carbon	48.24	54.20
Btu	11,660	13,101

Ultimate Analysis:

	<u>As Received</u>	<u>Dry Basis</u>
% Moisture	11.00	
Carbon	64.73	72.73
Hydrogen	4.39	4.93
Nitrogen	1.33	1.50
Chlorine	0.30	0.34
Sulfur	1.85	2.08
Ash	8.28	9.30
Oxygen (by Difference)	8.12	9.12

Table 2. Experimental Results with 1 1/2 In. Extruder
(Illinois No. 6 Coal)

Coal Preparation

Screen Size 10/20 mesh (Tyler)
Drying 300°^r in air

Extruder Temperature:

	<u>Inches from Feed Port</u>	<u>Temperature, °F</u>
Coal Inlet	0	510
Feed Zone	8	520
Compression Zone	15	790
Metering Zone	25	790
Die	31-36	790

Extruder Data

Screw Speed 83 rpm
Coal Feed 9.1 lb/hr
Power 0.89 hp

Calculated Data

Power 10.2 lb/hp-hr
(248 BTU/lb)
Shear Stress in Die ---
Shear Rate in Die 105 sec⁻¹

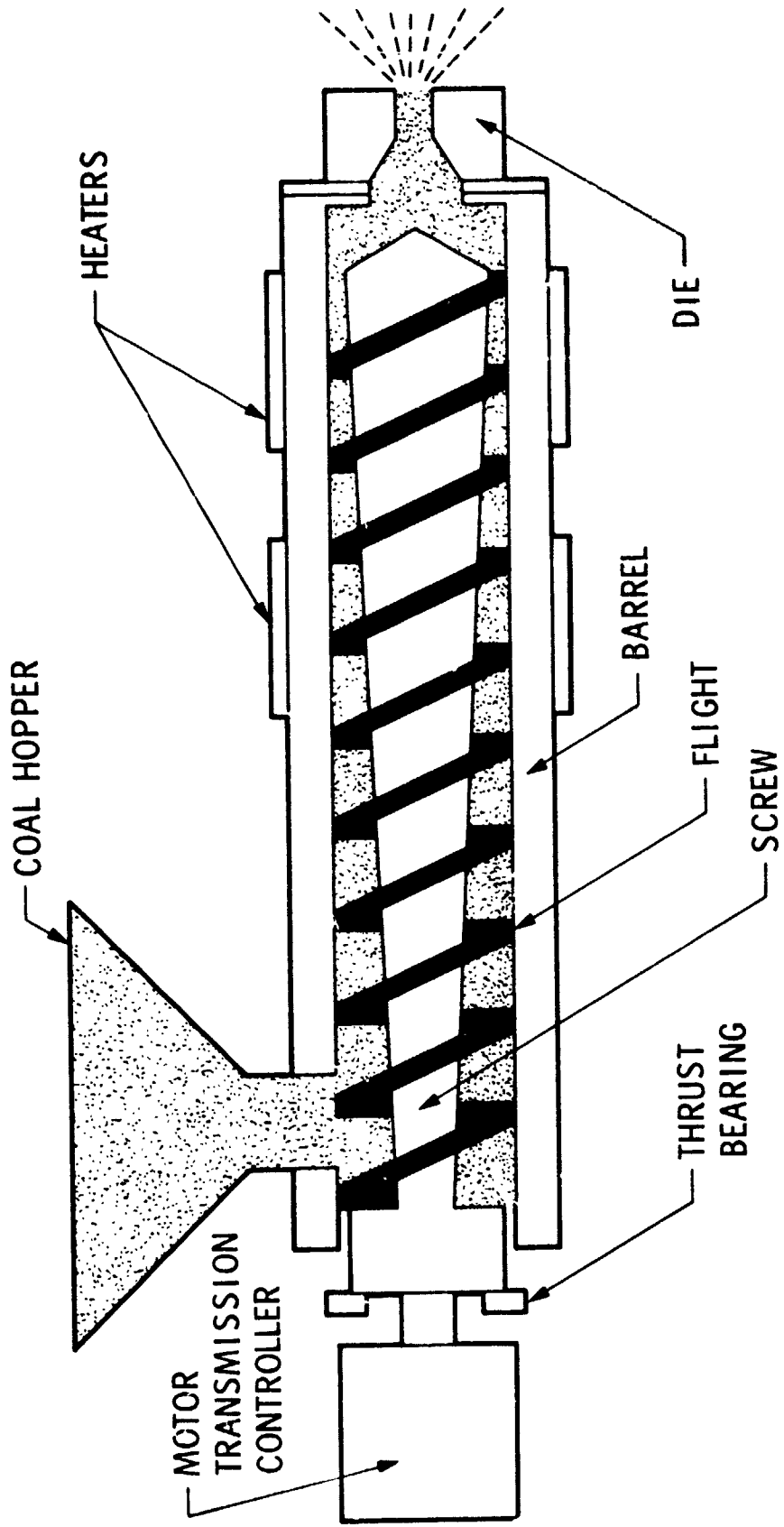

Figure 1. Schematic of a Compressing Screw Extruder

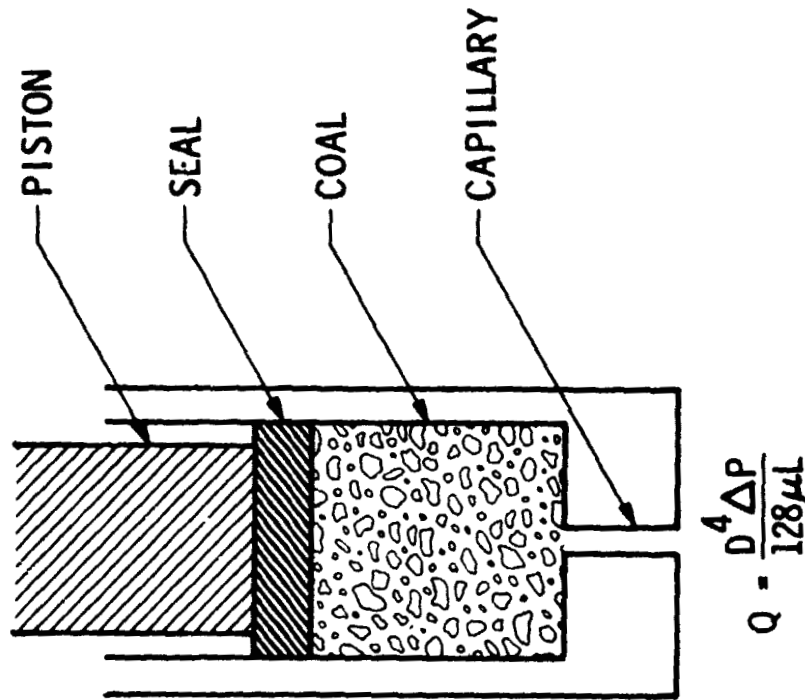

Figure 2. Schematic of a Capillary Rheometer

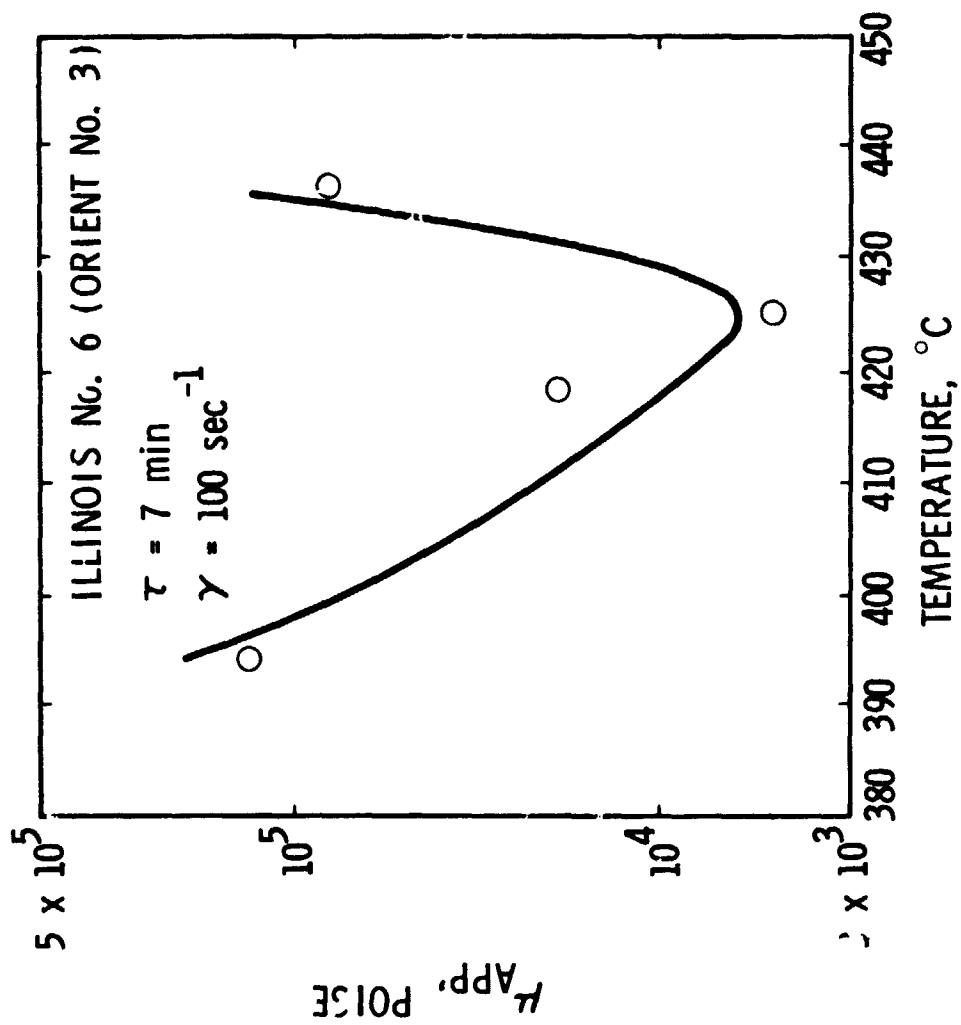

Figure 3. Temperature Dependence of Viscosity of Illinois No.6 Coal

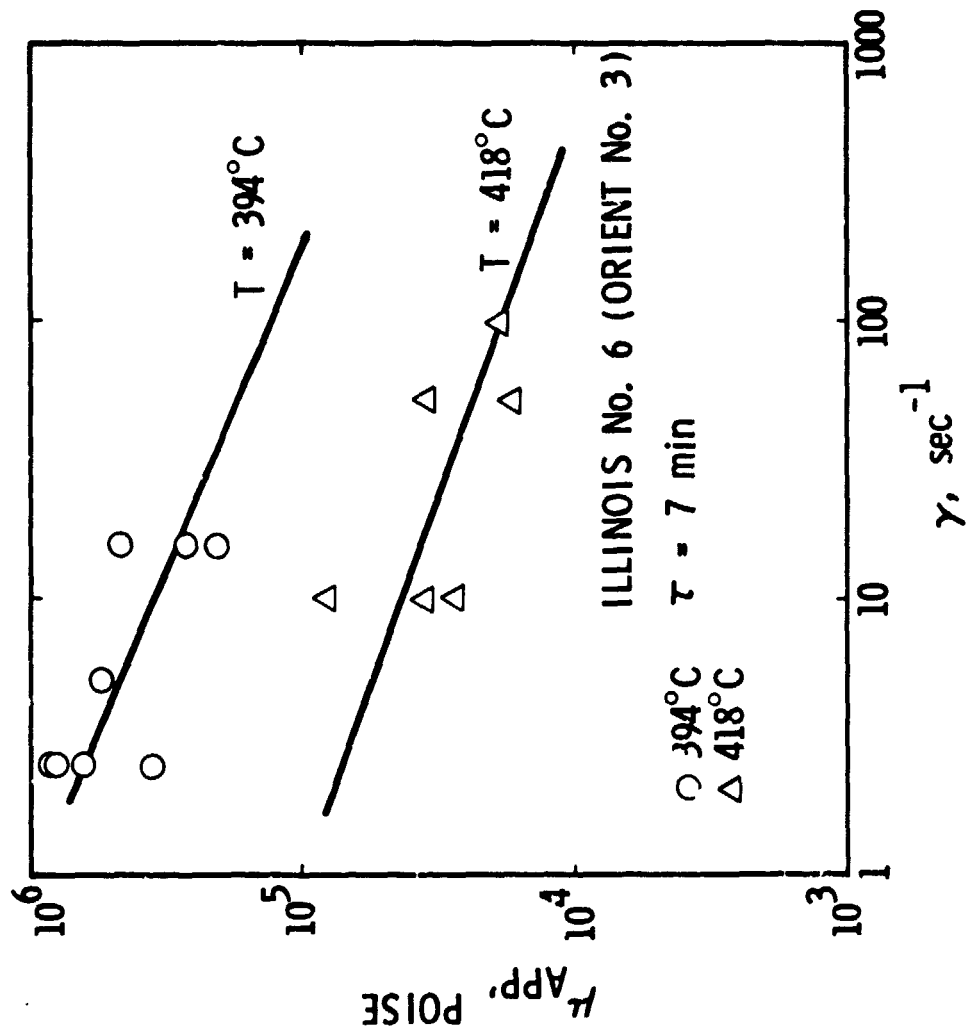

Figure 4. Shear-Rate Dependence of Viscosity of Illinois No.6 Coal