

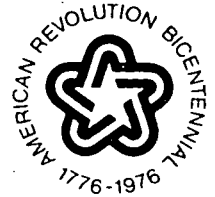

NATIONAL AERONAUTICS AND SPACE ADMINISTRATION  
WASHINGTON, D.C. 20546



NOV 1 1977

REPLY TO  
ATTN OF: GP

TO: KSI/Scientific & Technical Information Division  
Attn: Miss Winnie M. Morgan

FROM: GP/Office of Assistant General  
Counsel for Patent Matters

SUBJECT: Announcement of NASA-Owned U.S. Patents in STAR

In accordance with the procedures agreed upon by Code GP and Code KSI, the attached NASA-owned U.S. Patent is being forwarded for abstracting and announcement in NASA STAR.

The following information is provided:

U.S. Patent No. : 4,051,558

Government or  
Corporate Employee : U.S. Government

Supplementary Corporate  
Source (if applicable) : ~~~~~

NASA Patent Case No. : ARC-10,916-1

NOTE - If this patent covers an invention made by a corporate employee of a NASA Contractor, the following is applicable:

YES  NO

Pursuant to Section 305(a) of the National Aeronautics and Space Act, the name of the Administrator of NASA appears on the first page of the patent; however, the name of the actual inventor (author) appears at the heading of column No. 1 of the Specification, following the words "...with respect to an invention of ..."

*Bonnie L. Henderson*

Bonnie L. Henderson

Enclosure



[54] MECHANICAL ENERGY STORAGE DEVICE FOR HIP DISARTICULATION

Attorney, Agent, or Firm—Darrell G. Brekke; John R. Manning

[75] Inventor: Wilbur C. Vallotton, Los Gatos, Calif.

[57] ABSTRACT

[73] Assignee: The United States of America as represented by the United States National Aeronautics and Space Administration, Washington, D.C.

An artificial leg includes a trunk socket, a thigh section hingedly coupled to the trunk socket, a leg section hingedly coupled to the thigh section and a foot section hingedly coupled to the leg section. A mechanical energy storage device, such as a spring, is operatively associated with the artificial leg for storage and release of energy during a normal walking stride of the user. More particularly, energy is stored in the mechanical energy storage device during a weight-bearing phase of the walking stride when the user's weight is on the artificial leg and energy is released during a phase of the normal walking stride, when the user's weight is removed from the artificial leg. The stored energy is released from the energy storage device to pivot the thigh section forwardly about the hinged coupling thereof to the trunk socket. A dash-pot is coupled between the lower end of the thigh section and the foot section for damping flexion of the knee joint after a certain predetermined extent of ankle flexion is achieved to derive a more normal stride and cadence.

[21] Appl. No.: 701,448  
[22] Filed: June 30, 1976

[51] Int. Cl.<sup>2</sup> ..... A61F 1/00; A61F 1/08  
[52] U.S. Cl. .... 3/1.2; 3/15; 3/29

[58] Field of Search ..... 3/14, 15, 1.2, 17 R, 3/18, 19, 22, 23, 25, 29, 2

[56] References Cited  
U.S. PATENT DOCUMENTS

1,299,980 4/1919 Marcinko ..... 3/15  
1,312,599 8/1919 Webb ..... 3/1.2 X

FOREIGN PATENT DOCUMENTS

228,940 10/1959 Australia ..... 3/15

Primary Examiner—Ronald L. Frinks

8 Claims, 5 Drawing Figures

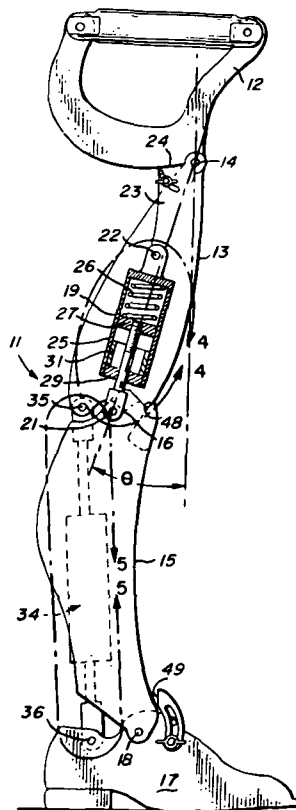

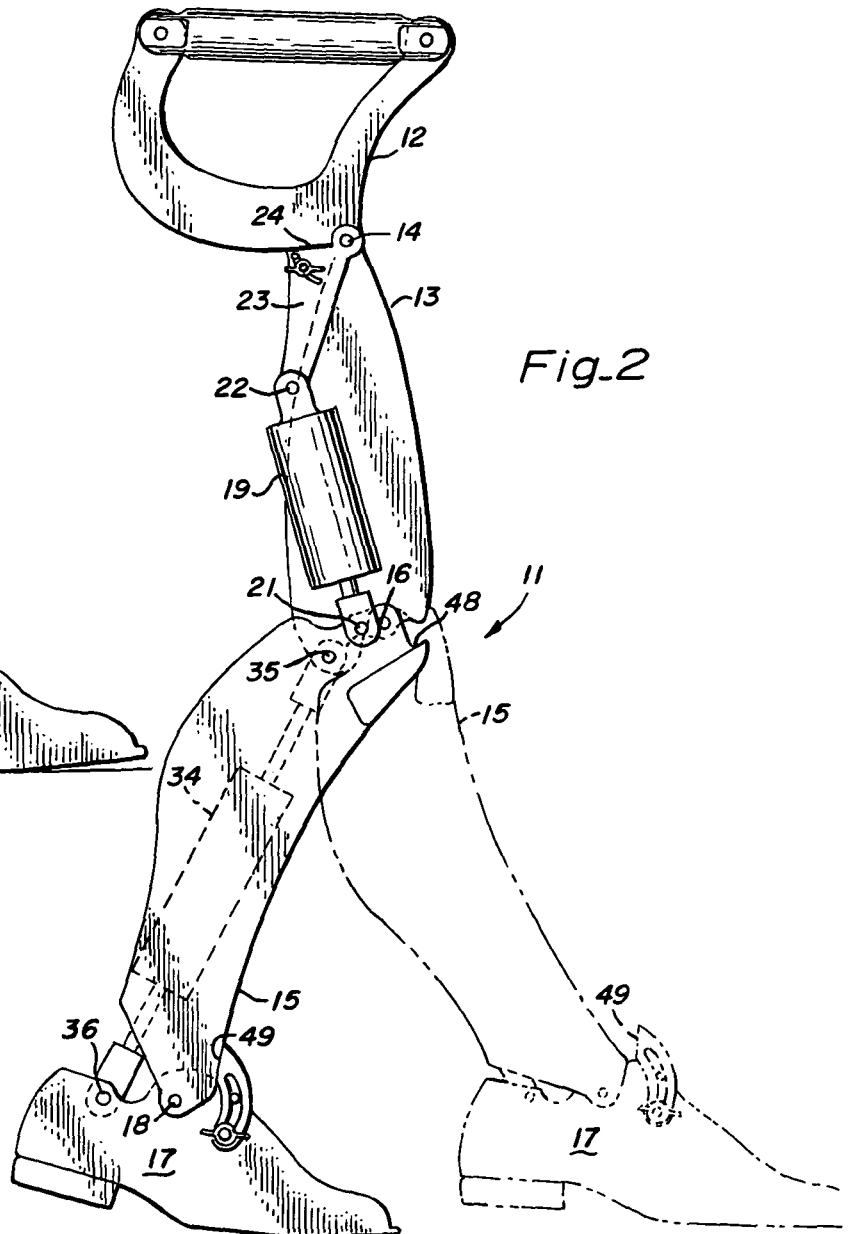
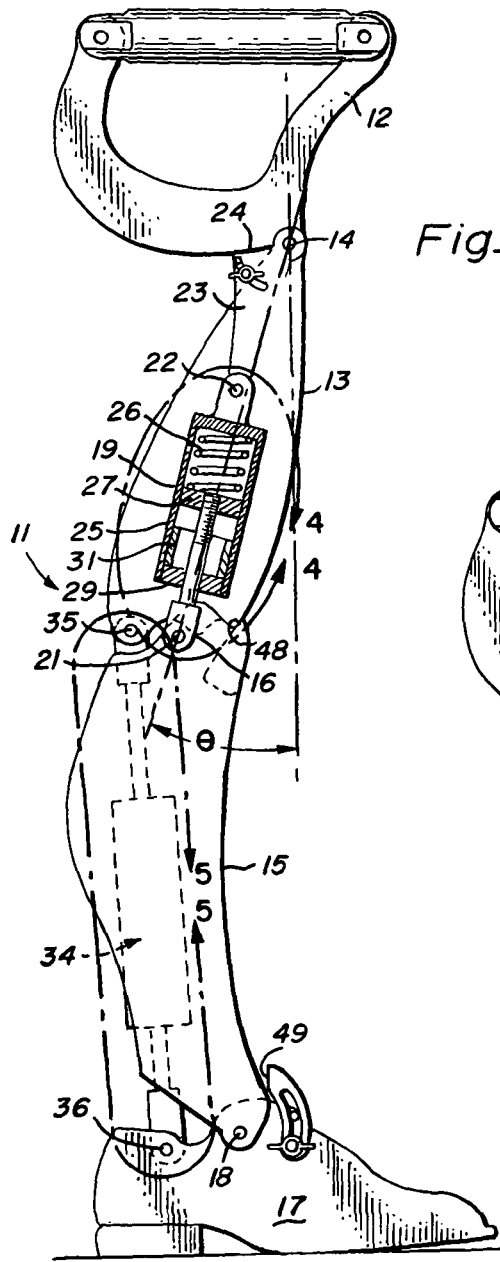

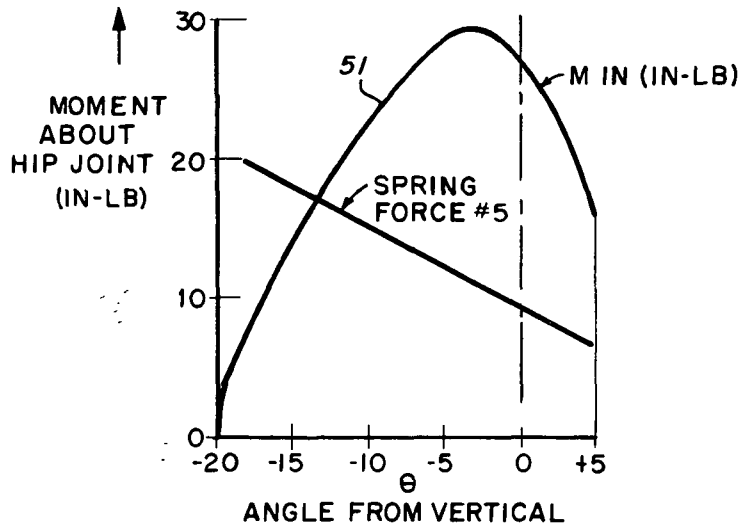

Fig.3

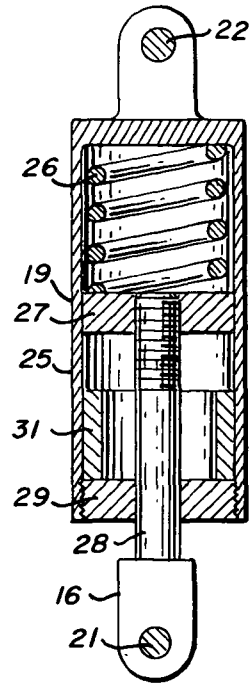

Fig.4

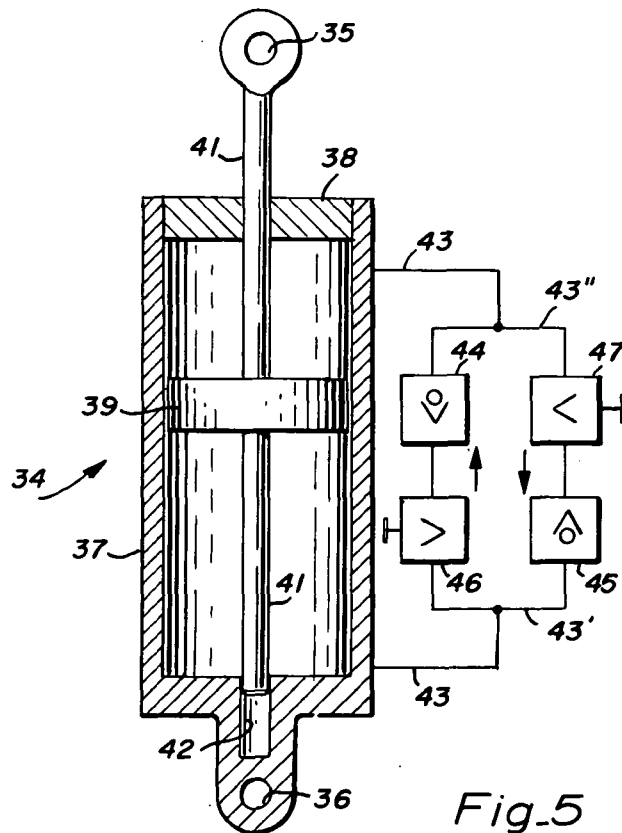

Fig.5

## MECHANICAL ENERGY STORAGE DEVICE FOR HIP DISARTICULATION

The invention described herein was made by an employee of the United States Government and may be manufactured and used by or for the Government for Governmental purposes without the payment of any royalties thereon or therefor.

### BACKGROUND OF THE INVENTION

The present invention relates in general to artificial legs and more particularly to an improved artificial leg of the type including a hip joint and incorporating an energy storage device for automatically flexing the hip joint of the artificial leg, much as a normal hip joint flexes.

### DESCRIPTION OF THE PRIOR ART

Heretofore, artificial legs have been used for replacing an entire leg including the hip joint. Such artificial legs have included a trunk socket to receive the trunk portion of the user. An artificial thigh section, an artificial lower leg section and an artificial foot section, all connected together by pivotable joints, were joined to the trunk socket by means of a pivotable hip joint. Such an artificial leg is designed to provide a portable, patient-controlled, stable platform in which the patient can rest his weight on the weight bearing phase of the user's stride. Optimum performance is obtained through the proper alignment of the various sections of the artificial leg. Once the artificial leg is properly aligned, and after a small amount of training, a patient can regain the ability to walk, but normally the patient's gait is badly distorted.

The distortion is caused primarily by the maneuvers through which the patient must go to lift the artificial leg and swing it forward to take the next step. The normal leg during a normal swing is flexed at both the hip and knee, thus providing adequate clearance between the foot and the ground. Unfortunately, this is not the case with the prior art artificial leg which is at its maximum length as the foot passes close to the ground leaving no clearance since both the natural leg and the artificial leg are the same length. To obtain clearance, the patient elevates his hip on the prosthesis side and swings his artificial leg slightly to the side when bringing it forward or the patient vaults by raising on the toe of the normal foot in order to obtain clearance of the artificial leg. Obviously, the net result is a distorted gait. Also, the cadence of the stride is somewhat slowed because the lower leg portion of the artificial limb moves forward under the influence of gravity. The resultant cadence is slow because it is dependent upon this type of pendulum action.

### SUMMARY OF THE PRESENT INVENTION

The principal object of the present invention is the provision of an improved artificial leg of the type including a trunk socket and more particularly to such an artificial leg including the provision of an energy storage device which stores energy during one phase of the normal walking stride and releases energy during another phase to flex the hip joint of the artificial leg, much as a normal hip joint flexes.

In one feature of the present invention, an artificial leg is provided which includes a trunk socket, a thigh section, a leg section and a foot section, said sections of

the artificial leg being hingedly coupled together via the intermediary of a hip joint, a knee joint and a foot joint, respectively. An energy storage device is coupled between the trunk socket and at least one of said thigh and leg sections for storage of energy during one phase of the normal walking stride and release of this energy during another phase to flex the hip joint, much as a normal hip joint flexes.

In another feature of the present invention, a dash-pot is coupled between the thigh section and the foot section to damp flexion of the knee joint after a predetermined flexion of the foot joint is obtained to derive a more nearly normal stride and cadence.

Other features and advantages of the present invention will become apparent upon a perusal of the following specification taken in connection with the accompanying drawings wherein:

### BRIEF DESCRIPTION OF THE DRAWINGS

FIG. 1 is a side elevational view, partly in section, of an artificial limb incorporating features of the present invention, such limb being shown in the weight bearing phase of a user's stride,

FIG. 2 is a view similar to that of FIG. 1 depicting the knee flexing phase and the swing through phase of the user's stride,

FIG. 3 is a plot of moment about the hip joint versus angle  $\theta$  from the vertical for the thigh section depicting the spring force of the energy storing device and the resultant moment produced on the thigh section about the hip joint for the artificial leg of the present invention,

FIG. 4 is an enlarged sectional view of a portion of the structure of FIG. 1 delineated by line 4-4, and

FIG. 5 is an enlarged sectional view, partly in block diagram form, of the dash-pot portion of the artificial leg delineated by line 5-5 of FIG. 1.

### DESCRIPTION OF THE PREFERRED EMBODIMENTS

Referring now to FIG. 1 there is shown an artificial leg 11 incorporating features of the present invention. The artificial leg 11 includes a conventional trunk socket portion 12 for receiving the lower trunk of the body of the user and for affixing the artificial leg 11 to the trunk of the user. A hollow thigh section 13 is hingedly coupled to the trunk socket 12 via the intermediary of a pivotable hip joint 14. A hollow leg section 15 is hingedly coupled to the lower end of the thigh section 13 via the intermediary of a pivotable knee joint 16. A foot section 17 is hingedly coupled to the lower end of the leg section 15 via the intermediary of a pivotable foot joint 18.

An energy storage device 19 is coupled between the hip joint and a pivotable joint 21 at the upper end of the leg section 15 just rearward of the knee joint 16 via the intermediary of a floating link-type connection. More particularly, the energy storage device 19 is pivotably connected at its lower end at 21 to the leg section 15, whereas its upper end is pivotably connected at 22 to the lower end of a link 23 which in turn is pivotably connected at its upper end to the hip joint 14. Link 23 includes an adjustable rubber stop portion 24 which abuts at its rearward-most extremity of movement about the hip joint 14 against the lower surface of the trunk socket 12. When the artificial leg 11 is in the weight-bearing phase as shown in FIG. 1, the stop 24 abuts the socket 12, the intermediate joint 22 takes a position