

# FATIGUE OF TITANIUM ALLOYS IN A SUPERSONIC- CRUISE AIRPLANE ENVIRONMENT

L. A. Imig  
NASA Langley Research Center

## SUMMARY

Many fatigue tests have been conducted to explore thermal effects on structural materials in the time since supersonic commercial flight first received serious consideration. Most of the testing has been conducted with coupons of structural materials because large numbers of realistic simulated structures are prohibitively expensive. The test programs conducted by several aerospace companies and NASA, summarized in this paper, studied several titanium materials previously identified as having high potential for application to supersonic-cruise airplane structures. These studies demonstrate that the temperature (560 K) by itself produced no significant degradation of the materials. However, the fatigue resistance of titanium-alloy structures, in which thermal and loading effects are combined, has been studied insufficiently. The predominant topic for future study of fatigue problems in Mach 3 structures should be the influences of thermal stress — particularly, the effects of thermal stress on failure location.

## INTRODUCTION

In the early 1960's, worldwide anticipation of supersonic commercial flight prompted extensive study of materials and thermal effects for supersonic airplane structures. The predominant questions were: Will materials stably withstand the prolonged exposure to elevated temperature? How will structures respond to prolonged temperature and thermal stresses? What test procedures will be required to verify structural fatigue resistance to the loads, temperatures, and thermal stresses experienced by a transport airplane during supersonic flight? Since then, many tests have been conducted by NASA and the aerospace industry to study thermal effects on materials. But structural response to temperature and thermal stress has received little study in the United States because the cost of sample structures is very high, and because the driving force, development of a U.S. supersonic transport, was removed. The only continuing research uses coupon specimens to study test procedures to account for the loading, temperature, and thermal stress expected in supersonic-cruise airplanes.

This paper summarizes the NASA/industry research and discusses the results insofar as they address the development of simplified testing procedures for supersonic-cruise airplane materials and structures. The research programs discussed here all used titanium alloys. Much more recently, composite material development has produced materials showing potential sufficient

to warrant study of their applicability to supersonic-cruise airplane structures. Such studies have not yet been conducted.

## SYMBOLS

The units for physical quantities used in this paper are given in the International System of Units (SI); however, measurements during the investigations were made in U.S. Customary Units.

E	modulus of elasticity, GPa
$K_{Tg}$	gross-area stress-concentration factor
M	Mach number
S	stress, MPa
$S_d$	one-g design stress on gross section (stress on gross section for level unaccelerated flight at maximum gross mass), MPa
$S^*$	maximum gross stress in most frequently occurring simulated flight, MPa
T	temperature, K
$T_s$	stagnation temperature, K
$T_{sol}$	solidus temperature, K
$\Delta T$	temperature range, K
$\alpha$	coefficient of linear thermal expansion, 1/K

### Abbreviations:

CA	constant amplitude
DA	duplex annealed
FBF	flight-by-flight
MA	mill (single) annealed
STA	solution treated and aged
SW	spotwelded
TA	triplex annealed
6-4	titanium alloy Ti-6Al-4V
8-1-1	titanium alloy Ti-8Al-1Mo-1V

## MATERIAL SELECTION AND TESTING OPTIONS

Extensive material characterization studies (refs. 1-10) identified titanium alloys as leading candidates for structural applications at a Mach number of 3. These studies were organized to screen a large number of titanium alloys, stainless steels, superalloys, and for comparison, some aluminum alloys. The studies considered such diverse topics as availability, fabricability, mechanical properties, corrosion resistance, and thermal effects. Thus, titanium alloys were selected only after very broad deliberations.

Most of the research discussed in this paper was initiated at least 10 years ago when Ti-8Al-1Mo-1V was the leading titanium-alloy candidate so the early research programs used that alloy. Since then, alloy Ti-6Al-4V has proven to have better salt-corrosion resistance than Ti-8Al-1Mo-1V. Except where salt is an important part of the test environment, trends in data from one alloy seem representative for the other alloy, as discussed later in this paper.

Material selection has an important influence on the procedures employed for structural fatigue tests. For example, figure 1 shows that Mach 3 structures of the stainless steel, superalloy, or titanium alloy shown would operate at much lower temperatures relative to their ultimate thermal capabilities than would be the case for the aluminum alloy in a Mach 2 structure. Thus, thermal effects on the materials are likely to be much more important for the Mach 2 aluminum alloy structure than for Mach 3 structures of the other materials. Consequently, the rigorous simulation of thermal effects is likely to be much more important in fatigue tests of Mach 2 aluminum alloy structure than for structures of the other three materials shown.

Such thermal considerations for supersonic-cruise-related fatigue tests lead to several options as shown in the following table:

Thermal options		Test objectives			Speed	Expense
		Verify service life	Identify failure locations	Account for temperature and thermal stress effects		
Cyclic		Yes	Yes	Yes	Slow	Most
C o n s t a n t	Hot	Not directly	?	Some	Fast	↓ Least
	Presoaked			Some		
	Ambient			No		

The first option, cyclic temperature, provides the best simulation of supersonic-cruise airplane operation. Such a test is likely to satisfy the predominant test objectives shown in the table, but will be very slow and expensive — especially for large test articles and for temperature cycles as are being employed in fatigue tests of Concorde (refs. 11 and 12).

The other three options listed avoid temperature cycles. Thus, these constant-temperature options would fail to simulate the cyclic temperatures and temperature effects of repeated supersonic-cruise flights. To recommend or undertake a constant-temperature test would require an independent justification that the procedure was acceptable.

The three constant-temperature options would allow testing speeds nearly as fast as for subsonic airplanes. Such tests would obviously be much less expensive than cyclic-temperature tests, but carry the risk of compromising some important test objectives. To insure acceptable compromises, the test procedures for the American SST were planned to rely heavily on empirical and analytical techniques developed from extensive preliminary testing programs (refs. 13 and 14).

The obviously high cost of cyclic-temperature structural fatigue tests and the low relative temperature for a titanium structure at  $M = 3$  justify exploration for relatively fast and inexpensive fatigue tests, perhaps constant-temperature fatigue tests, which would provide suitable information about the life and failure locations of the test article. Such exploratory research has been in progress for more than 10 years. Most of the effort has employed coupon specimens or small components, but some early work was conducted with larger specimens. In most of the work, thermal stresses were simulated mechanically or purposely minimized; thus, little information about thermal stress influences on failure locations has been derived.

The remainder of this paper will discuss previous studies that addressed the simplification of testing procedures from the prolonged cyclic-temperature conditions experienced by a supersonic-cruise airplane. Wing structure was considered in all of these investigations.

#### FATIGUE RESEARCH PROGRAMS

The research programs discussed in this section originated after the decision to construct an American SST from predominantly titanium alloys; thus, these programs all used titanium materials. The programs were conducted at the Lockheed-California Company, The Boeing Commercial Airplane Company, the LTV Aerospace Corporation, and the Langley Research Center. The important aspects of the gust and maneuver spectrums employed for these studies were nearly the same; thus, the results of the studies may be compared directly.

## Tests at the Lockheed-California Company

In a recently completed series of flight-by-flight fatigue tests, the Lockheed-California Company explored potential thermal simplifications in fatigue tests (refs. 15 and 16). Their program included a variety of material and specimen combinations, and test conditions as shown in the following tabulations:

Sheet material	Specimen configuration	Kind of fatigue test	Test temperatures
8-1-1 MA 8-1-1 DA 8-1-1 TA 6-4 MA	Central-hole coupon	Accelerated	Ambient (300 K) Hot (530 K) Cyclic (300 K to 530 K)
(Extrusions) 8-1-1 MA 6-4 STA	Central-hole coupon	Real-time	Cyclic (300 K to 530 K)
8-1-1 DA	Coupon with single-spotweld tab		

As shown in figure 2, an accelerated simulated flight required only 5 sec (19 sec for accelerated tests with cyclic temperature), compared with about 65 min for real-time flight simulation. In all these tests, a mechanical tensile stress increment during cruise and a compressive stress increment during descent were added to the one-g stress to simulate the thermal stress for wing substructure. All of the tests were conducted at a gross-area one-g design stress of 172 MPa. As a rule, four replicate tests were conducted for accelerated test conditions and six for real-time test conditions.

The median fatigue lives from Lockheed's accelerated tests are shown in figure 3 normalized by the median lives from their real-time tests. The top row of bars is for constant elevated-temperature tests, the middle row is for room-temperature tests, and the bottom row is for cyclic-temperature tests.

None of the accelerated-test methods produced a consistent ratio of fatigue life to real-time life. Within each row, the bars differ in height by at least a factor of 3.

Room-temperature and cyclic-temperature accelerated tests of some materials produced fatigue lives that were longer than the real-time lives; for other materials, these accelerated tests produced fatigue lives that were shorter than the real-time lives. For a given material, the fatigue life from cyclic-temperature accelerated tests was about equal to the life from room-temperature accelerated tests. Thus, the added experimental complication attendant to the temperature cycles for these accelerated tests proved of little value.

Only the constant elevated-temperature tests produced a consistent result: their fatigue lives were always shorter than for the corresponding real-time test.

#### Tests at NASA

NASA has conducted a separate series of flight-by-flight fatigue tests (refs. 17 and 18) which complement Lockheed's program. The following table contains the major components of each:

Test condition	Lockheed	NASA
Design stress	172 MPa	138, 165, 195 MPa
Materials	7	3
$K_{Tg}$	3	5
Load spectrum	only slightly different	
Real-time tests	1 hr per flight, 1 stress profile	1.5 hr per flight, 3 stress profiles

In the NASA tests, the stresses in each flight simulated thermal stresses for the substructure (as in the Lockheed tests), or thermal stresses for the skin (fig. 4), or simulated a reference flight without thermal stress. Accelerated tests were conducted at constant temperatures of 300 K and 560 K. In real-time tests, the temperature was cycled within each flight from 300 K to 560 K. Gross-area one-g design stresses for these tests were 138, 165, and 193 MPa.

For the schematic flights shown in figure 4, the blocks represent, in sequence, the cyclic stresses for climb, cruise, and descent segments of flight (ref. 17). The minimum stress in all these flights was -0.50 of the one-g design stress.

The NASA results are summarized in figure 5 for both accelerated and real-time tests with the two thermal-stress simulations, and for the reference stress profile. These data are plotted against  $S^*$  (see fig. 5), which established the range of the present ground-air-ground (GAG) cycles, because much previous research has shown that range to be the predominant source of fatigue damage for this type of flight-simulation loading. The lower left of the figure, for accelerated tests at 560 K, shows that the results of tests at all three design stresses fall reasonably well on a smooth curve. The dashed curve in the plot represents the results of room-temperature tests (ref. 18). The lives from room-temperature tests were about twice as long as for tests at 560 K. The curves for both temperatures indicate that the test results correlated well with only the GAG cycles. Thus, these results are consistent with extensive earlier data that establish the importance of GAG cycles (see

refs. 13 and 19 for examples). In the present tests, the only effect of the simulated thermal stresses was to change the GAG-cycle range. In structures, the predominant influence of thermal stresses is also likely to be on GAG cycles. Thus, the good correlations shown on figure 5 suggest that the influence of thermal stresses on fatigue can be simply accounted for by calculating their contribution to GAG cycles.

The lower right part of figure 5 shows that the lives of all the real-time tests were longer than for accelerated tests at 560 K for corresponding stress levels. The data include the effects of quite different thermal stress conditions and include the cumulative effects of the long cyclic thermal exposure. The constant-elevated-temperature data provide a very good lower bound for the results under the more complicated test conditions. These observations suggest that these constant-elevated-temperature data could be used as design data for all of the real-time conditions represented in the figure.

#### Tests at The Boeing Commercial Airplane Company

Specimens with somewhat more realistic structural features than the Lockheed and NASA specimens were prepared for Boeing's study of test simplification procedures (ref. 20). Boeing's specimen, figure 6, consisted of two components joined by commercially available threaded fasteners. Boeing conducted flight-by-flight fatigue tests in which the stress sequences were identical to those in the NASA tests. Five specimens were tested in each of three accelerated-test series conducted at a one-g design stress of 207 MPa.

The first series included cyclic differential heating of the two specimen components to simulate Mach 3 temperature conditions (at one flight per min) and to provide a set of reference fatigue lives. The other two series of tests were conducted to evaluate two simpler test procedures. These series were conducted at two flights per minute and at constant temperature. Of the two series, one was conducted entirely at room temperature, but specimens for the other were presoaked for 500 hours at 560 K before being tested at room temperature as had been proposed in reference 13 for the American SST.

The results of all three series of tests, figure 6, indicate only small differences among the fatigue lives. Boeing's data show that the cyclic-temperature (reference) tests produced lives about equal to those from their room-temperature tests — a result very similar to that from Lockheed's tests.

#### Tests at the LTV Corporation

The LTV Corporation tested large titanium-alloy box-beam covers representing structure for commercial supersonic-cruise airplanes (refs. 21 and 22). Their specimens, of Ti-8Al-1Mo-1V, were about 300 cm by 58 cm (see fig. 7). Four covers each were fabricated by riveting, spotwelding, and fusion welding. They contained a transverse splice, a hand hole, and a structural door to represent typical structural features.

Specimens for each fabrication method were tested in three ways. For one test, only constant-amplitude GAG cycles were applied. The cycles ranged from the one-g stress of 172 MPa to -86 MPa, and the entire test was at room temperature. In another test, only constant-amplitude cruise cycles were applied. The mean stress during these cruise cycles included a positive increment of stress to simulate mechanically a thermal stress for a spar cap or a similar interior component. The alternating stresses applied about that mean resulted in test stresses of  $241 \pm 43$  MPa, and the entire test was at 560 K. The remaining two covers of each type were tested in a composite test combining both flight-by-flight and block loading as follows. The climb and GAG stresses for 240 flights were applied flight-by-flight at room temperature; the cruise stresses for 240 flights were then applied in a randomly arranged block at 560 K. Descent stresses were neglected because they were below the fatigue limit. Such blocks of this composite loading were repeated until the covers failed or the tests were terminated for other reasons.

For the riveted and spotwelded covers, constant-amplitude tests identified the same critical crack locations as the block tests. But for fusion-welded covers the crack locations were different in the three kinds of tests. Thus, the adequacy of these simplified (constant-amplitude) tests for identifying the critical failure locations depended on the fabrication method.

#### DISCUSSION OF RESULTS

All of the data reviewed in earlier sections of this paper are combined in figure 8 to permit broader discussion of the results than was permissible when discussing only the individual investigations.

The NASA results shown are for tests of all three titanium materials. The results of accelerated tests of all three materials at 560 K are represented by the solid curve shown. The fatigue lives of these materials were about the same in these tests. The fatigue lives from real-time tests of the three materials were also about equal (see open circles, fig. 8). These results demonstrate that the fatigue resistance of these three materials is substantially the same, and suggest that the fatigue design allowable stresses for these materials would be the same — a conclusion similar to that given in reference 23 for several aluminum alloys.

Lockheed's data from coupons tested at 530 K are represented by the diamond symbol and the dashed curve. The symbol is plotted at the average life (see ref. 15 for data) of their seven kinds of specimens. The curve is shown simply to approximate a trend from their data.

The large separation between the two curves reflects the influence of the stress-concentration factors for the coupons in the two series of tests. The stress-concentration factor, or more generally, a structural-quality index, is widely recognized as one of the major factors upon which structural fatigue life depends. The large separation between these curves quantifies the importance of that index.



The Boeing and LTV data in figure 8 each relate to the coupon data in a way consistent with considerations of their specimen qualities. The small Boeing components were very carefully fabricated, and their tests produced fatigue lives very close to the lives from Lockheed's open-hole coupons when their test temperatures are accounted for. The Boeing datum point represents room-temperature tests. Their report (ref. 20) shows that elevated temperature tests produced lives only one-half as long as at room temperature. Adjusting the data point in figure 8 to account for constant elevated temperature would put it very close to Lockheed's diamond. The LTV data, on the other hand, represent much larger specimens, in which uniformly high structural quality is much more difficult to maintain. Thus, the fatigue strength of the box-beam covers fell within the lower group of data. These limited data for titanium coupons and structure are consistent with other publications (refs. 24 and 25) reporting that the fatigue behavior of aluminum-alloy structures approximated that from notched aluminum-alloy specimens of  $K_T = 4$  to 5, but more data would be required to confirm that result for titanium structures.

The data in figure 8 were obtained from tests that employed substantially the same load spectrum, and these results inherently reflect that spectrum. The gust and maneuver stresses derived in reference 17 were for a hypothetical but realistic supersonic-cruise airplane. Assuming that these stresses will be representative for future supersonic-cruise airplanes, the results of figure 8 will have useful applicability to future supersonic-cruise airplanes.

#### Design Stresses

Figure 8 leads to interesting speculation about the use of such data to determine design stresses. Using the flight stresses of references 15 and 17 as examples, calculation of one-g design stresses from the  $S^*$  values shown indicates one-g design stresses of only about 120 MPa (17 ksi) up to 180 MPa (26 ksi) for a design life of 20,000 flights. For comparison, the following table shows values of one-g design stress currently being considered for wing structure of supersonic-cruise airplanes:

Airplane	One-g wing stress	Payload fraction
Boeing arrow-wing (ref. 26)	172 MPa (25 ksi)	0.065
Lockheed arrow-wing (ref. 27)	165 (24)	.065
LTV study (ref. 28)	155 (22.5)	.085

These design stresses are within the range of values determined from figure 8. But the selection of a particular value of design stress depends strongly on the assumed level of structural quality.

## A Concept for Design and Testing

The data in figures 5 and 8 show that if a structure were designed from constant-elevated-temperature fatigue data, but tested at room temperature, an appropriate factor would be required to establish the duration of the room-temperature test. Data from Boeing, Lockheed, and NASA show that the fatigue lives from room-temperature tests were about twice the lives from tests at 560 K. Therefore, a factor of 2 would be required to account for the temperature difference and an additional factor would be required beyond that, as is conventional in such fatigue tests, to account for experimental uncertainties.

A constant-temperature concept of design and testing recommends itself by its simplicity. But a major deterrent to adopting that concept is the risk that a constant-temperature test would fail to identify the critical structural failure locations. To remove that deterrent would require assurance from many tests of large components, showing that constant-temperature tests correctly identify the failure locations found to be critical in service-simulation tests. Insufficient funding has been available to conduct such an investigation in a generic way; if the adequacy of constant-temperature tests requires verification to support a future airplane development, the cost would then be more easily justified.

### Thermal Stress Considerations

Thermal stresses resulting from differential structural temperature have caused much concern about their potentially harmful effects on fatigue. Simple calculations of thermal stress ( $E\alpha \Delta T$ ) produce the values in the following table for the materials and applications shown:

<u>Material</u> Application	Temperature range, K		Calculated thermal stress range $E\alpha \Delta T$ , MPa	Reported thermal stresses, MPa
	Max.	Min.		
<u>Aluminum</u> Subsonic	320	220	170	20 to 80 (estimated)
<u>Titanium</u> Mach 3 cruise	560	220	340	35 to 140 (ref. 13)
<u>Aluminum</u> Mach 2 cruise	375	220	270	55 to 140 (ref. 29)

The calculated thermal-stress ranges in the third column represent theoretical limits for the temperature ranges shown. Practical considerations prevent such large stresses from developing. More realistic values calculated in references 13 and 29 by accounting for the practical restraints are listed in the fourth column. These values are only 0.1 to 0.5 of the theoretical values. How far below the theoretical values they are depends on thermal conductivity through joints, fabrication techniques to relieve thermal strains, adjacent

heat sinks, and other factors. The "practical fractions" of the theoretical values reflect that thermal stresses develop to a larger or smaller degree depending on the structural location.

Conventionally, aerodynamically induced thermal stresses are not directly accounted for in the design of subsonic airplane structure. Yet applying the "practicality factors" to the theoretical range for subsonic-flight temperatures indicates that thermal stresses of 20 to 80 MPa might realistically develop in subsonic airplane structure.

The upper values of thermal stress for the subsonic aluminum and Mach 3 titanium applications (80 and 140 MPa) are of about the same size as the respective one-g design stresses. That observation provokes some very interesting discussion. If one-g-sized thermal stresses can be practically ignored, as they have been for subsonic airplanes, perhaps they can also be ignored for Mach 3 titanium airplanes. On the other hand, if such thermal stresses constitute a serious problem for Mach 3 structures, perhaps they must also be deliberately accounted for in subsonic-airplane structure. Of course, the larger the thermal stresses, the less advisable ignoring them becomes; thus, for a Mach 2 aluminum structure (Concorde) thermal stress considerations dictated that very elaborate thermal simulations be employed during fatigue testing. But even for Concorde, reference 29 suggested the possibility of safely ignoring thermal stresses in some structural locations.

#### CONCLUDING REMARKS

Many fatigue tests have been conducted to explore thermal effects on structural materials in the time since supersonic commercial flight first received serious consideration. Most of the testing has been conducted with coupons of structural materials because large numbers of realistic simulated structures are prohibitively expensive. The test programs summarized in this paper, conducted by several aerospace companies and NASA, studied several titanium materials previously identified as having high potential for application to supersonic-cruise airplane structures. These studies demonstrate that the temperature (560 K) by itself produced no significant degradation of the materials. However, the fatigue resistance of titanium-alloy structures, in which thermal and loading effects are combined, has been studied insufficiently. The predominant topic for future study of fatigue problems in Mach 3 structures should be the influences of thermal stress — particularly, the effects of thermal stress on failure location.

## REFERENCES

1. Raring, Richard H.; Freeman, J. W.; Schultz, J. W.; and Voorhees, H. R.: Progress Report of the NASA Special Committee on Materials Research for Supersonic Transports. NASA TN D-1798, 1963.
2. Anon.: Proceedings of NASA Conference on Supersonic-Transport Feasibility Studies and Supporting Research. NASA TM X-905, 1963.
3. Braski, David N.; and Heimerl, George J.: The Relative Susceptibility of Four Commercial Titanium Alloys to Salt Stress Corrosion at 550° F. NASA TN D-2011, 1963.
4. Illg, Walter; and Castle, Claude B.: Fatigue of Four Stainless Steels and Three Titanium Alloys Before and After Exposure to 550° F (561° K) up to 8800 Hours. NASA TN D-2899, 1965.
5. Illg, Walter; and Imig, L. A.: Fatigue of Four Stainless Steels, Four Titanium Alloys, and Two Aluminum Alloys Before and After Exposure to Elevated Temperatures for up to Three Years. NASA TN D-6145, 1971.
6. Phillips, Edward P.: Effect of Outdoor Exposure at Elevated Temperature on the Fatigue Life of Ti-8Al-1Mo-1V Titanium Alloy and AM 350 Stainless Steel Sheet. NASA TN D-5362, 1969.
7. Phillips, Edward P.: Effect of Outdoor Exposure at Ambient and Elevated Temperatures on Fatigue Life of Ti-6Al-4V Titanium Alloy Sheet in the Annealed and the Solution-Treated and Aged Condition. NASA TN D-7540, 1974.
8. Peterson, John J.: Fatigue Behavior of AM 350 Stainless Steel and Titanium 8Al-1Mo-1V Sheet at Room Temperature, 550° F, and 800° F. NASA CR-23, 1964.
9. Gideon, D. N.; Marschall, C. W.; Holden, F. C.; and Hyler, W. S.: Exploratory Studies of Mechanical Cycling Fatigue Behavior of Materials for the Supersonic Transport. NASA CR-28, 1964.
10. Healy, M. S.; Marschall, C. W.; Holden, F. C.; and Hyler, W. S.: The Fatigue Behavior of Materials for the Supersonic Transport. NASA CR-215, 1965.
11. N'Guyen, V. P.; and Ripley, E. L.: Design Philosophy and Fatigue Testing of the Concorde. Mann, J. Y.; and Milligan, I. S., eds.: Aircraft Fatigue—Design, Operational, and Economic Aspects. Pergamon Press, c. 1972. Pergamon Press (Australia) Pty Limited, pp. 403-436.
12. Ripley, E. L.: The Philosophy Which Underlies the Structural Tests of a Supersonic Transport Aircraft With Particular Attention to the Thermal Cycle. Advanced Approaches to Fatigue Evaluation. NASA SP-309, 1972, pp. 1-91.

13. Donaldson, D. R.; and Kenworthy, K. J.: Fatigue Design and Test Program for the American SST. Mann, J. Y.; and Milligan, I. S., eds.: Aircraft Fatigue—Design, Operational, and Economic Aspects. Pergamon Press, c. 1972. Pergamon Press (Australia) Pty Limited, pp. 437-476.
14. Doty, Ralph J.: Fatigue Design Procedure for the American SST Prototype. Advanced Approaches to Fatigue Evaluation. NASA SP-309, 1972, pp. 365-404.
15. Anon.: Fatigue Strength Evaluation of Titanium Materials for the Supersonic Transport Under Flight-by-Flight Loading Spectra. Lockheed-California Company Technical Report SST-66-2, 1966.
16. Lunde, Ted: Real-Time Testing of Titanium Sheet and Extrusion Coupon Specimens Subjected to Mach 2.7 Supersonic-Cruise Airplane Wing Stresses and Temperatures. NASA CR-2754, 1977.
17. Imig, L. A.; and Illg, Walter: Fatigue of Notched Ti-8Al-1Mo-1V at Room Temperature and 550° F (560° K) With Flight-by-Flight Loading Representative of a Supersonic Transport. NASA TN D-5294, 1969.
18. Imig, L. A.; and Garrett, L. E.: Fatigue-Test Acceleration With Flight-by-Flight Loading and Heating to Simulate Supersonic Transport Operation. NASA TN D-7380, 1973.
19. Naumann, Eugene C.: Evaluation of the Influence of Load Randomization and of Ground-Air-Ground Cycles on Fatigue Life. NASA TN D-1584, 1964.
20. Watanabe, R. T.: Acceleration of Fatigue Tests for Built-up Titanium Components. NASA CR-2658, 1976.
21. Peterson, John J.: Fatigue Behavior of Ti-8Al-1Mo-1V Sheet in a Simulated Wing Structure Under the Environment of a Supersonic Transport. NASA CR-333, 1965.
22. Peterson, John J.: Fatigue Behavior of a Fusion Welded Ti-8Al-1Mo-1V Simulated Wing Structure Under the Environment of a Supersonic Transport. NASA CR-881, 1967.
23. Templin, R. L.; Howell, F. M.; and Hartman, E. C.: Effect of Grain Direction on Fatigue Properties of Aluminum Alloys. Product Engineering, Vol. 21, No. 7, July 1950, pp. 126-130.
24. Spaulding, E. H.: Design for Fatigue. Soc. Auto. Engr. Trans., Vol. 62, 1954, pp. 104-116.
25. Crichlow, Walter J.: On Fatigue Analysis and Testing for the Design of the Airframe. Fatigue Life Prediction for Aircraft Structures and Materials. LS-62, AGARD Lecture Series 62, Section 6. Printed by Technical Editing and Reproduction LTD. Harford House, 7-9 Charlotte St., London W1P1HD.

26. Turner, M. J.; and Grande, D. L.: Study of Metallic Structural Design Concepts for an Arrow-Wing Supersonic-Cruise Configuration. NASA CR-2743, 1976.
27. Sakata, I. F.; and Davis, G. W.: Evaluation of Structural Design Concepts for an Arrow-Wing Supersonic Cruise Aircraft. NASA CR-2667, 1976.
28. Baber, Hal T., Jr.; and Swanson, E. E.: Advanced Supersonic Technology Concept AST-100 Characteristics Developed in a Baseline-Update Study. NASA TM X-72815, 1976.
29. Atkinson, R. J.: The Testing of Supersonic Transport Structures in Fatigue. Dexter, Robert R., ed.: Proceedings of the Fourth Congress of the International Council of the Aeronautical Sciences. Spartan Books, Inc., Washington, D.C., 1965, pp. 259-279.

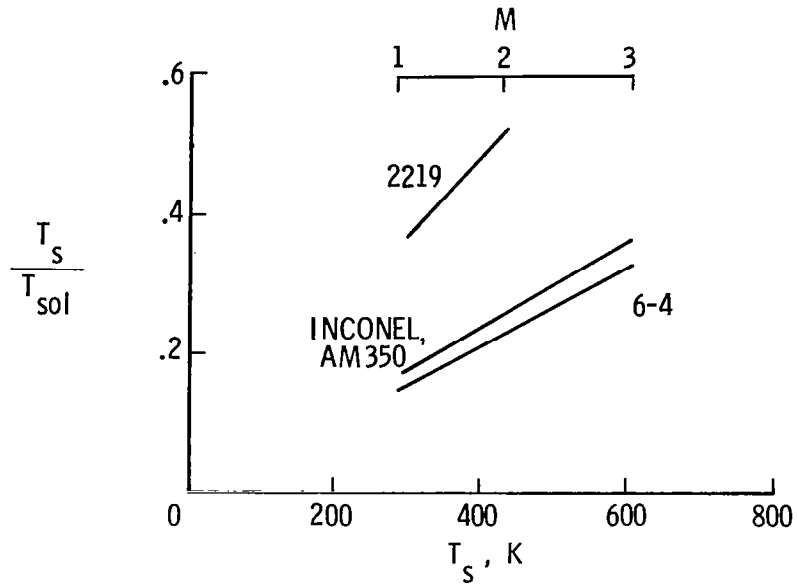

Figure 1.- Relative temperatures for skin materials.

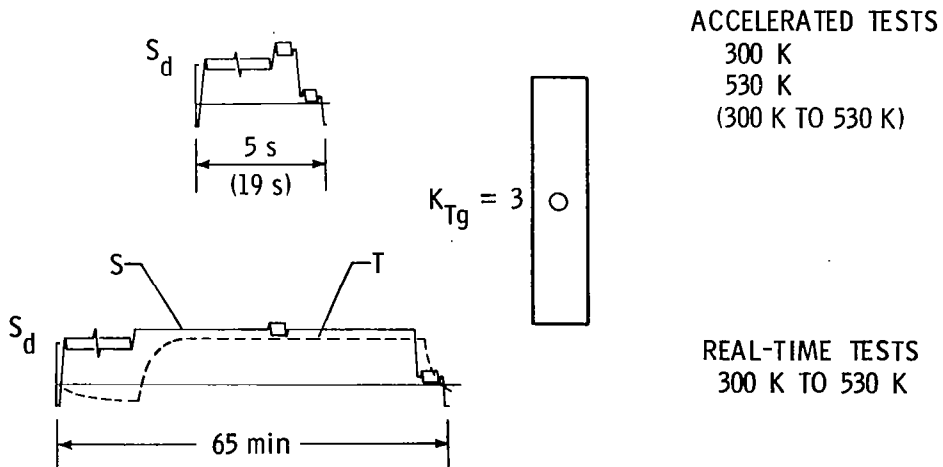

Figure 2.- Lockheed fatigue tests with simulated thermal stress (refs. 15 and 16). Gross-area one-g design stress.  $S_d = 172$  MPa.

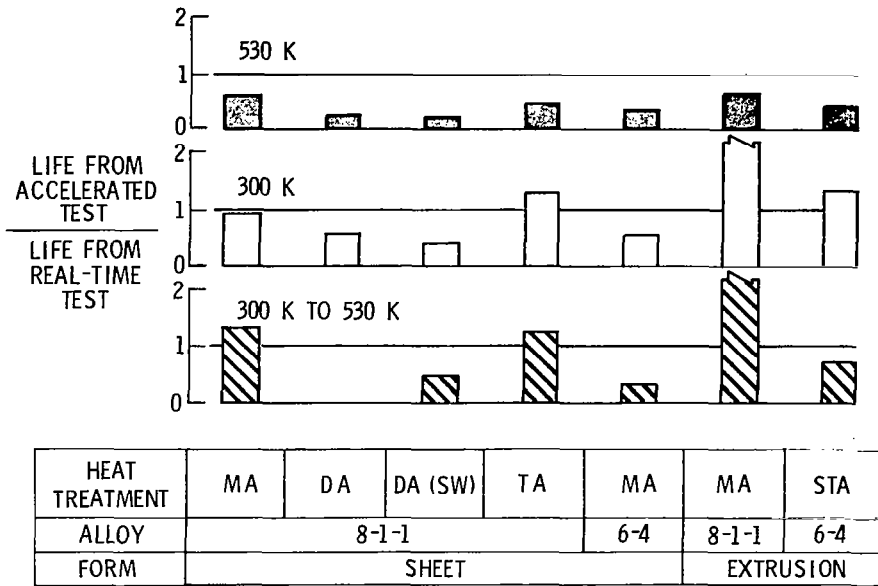

Figure 3.- Summary of Lockheed's fatigue tests. Crack initiation;  $K_{Tg} = 3$ .

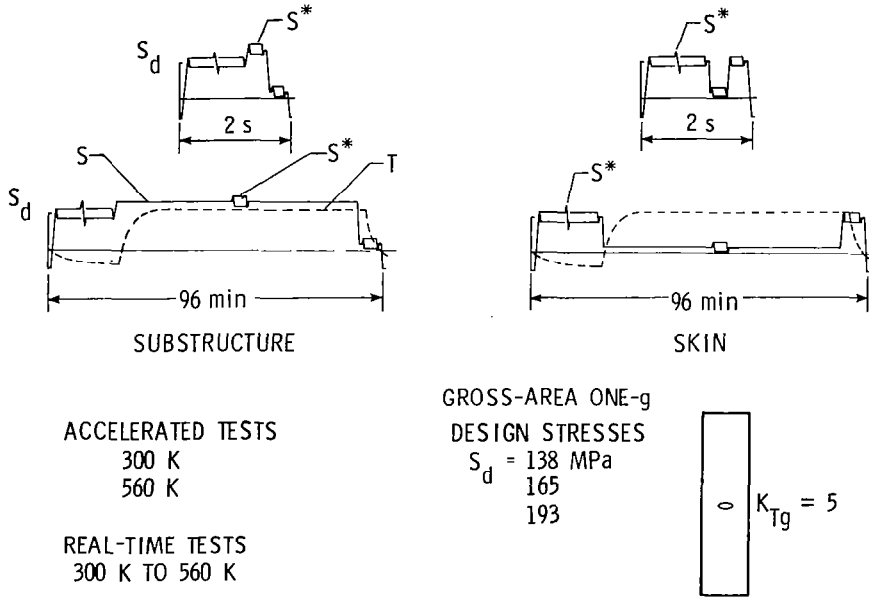

Figure 4.- NASA fatigue tests with simulated thermal stress (refs. 17 and 18).



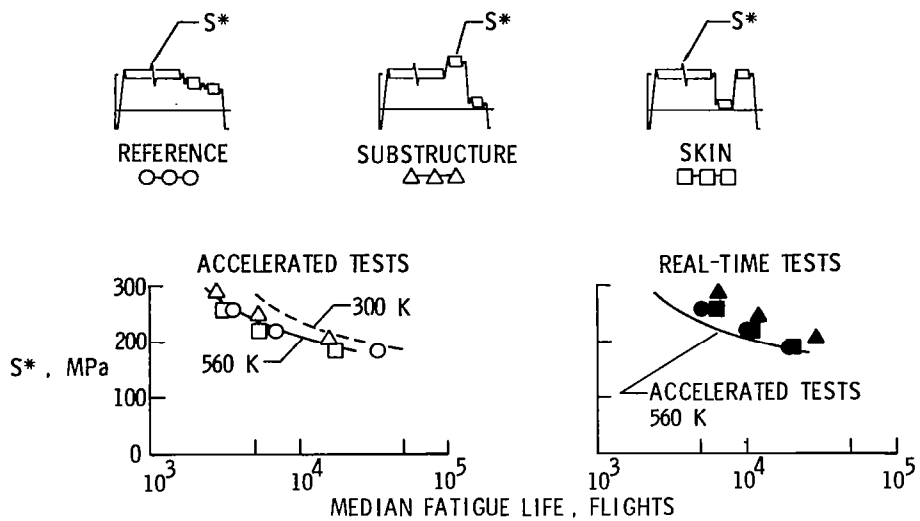

Figure 5.- Summary of NASA fatigue tests. Specimen failure;  
 DA Ti-8Al-1Mo-1V;  $K_{Tg} = 5$ .

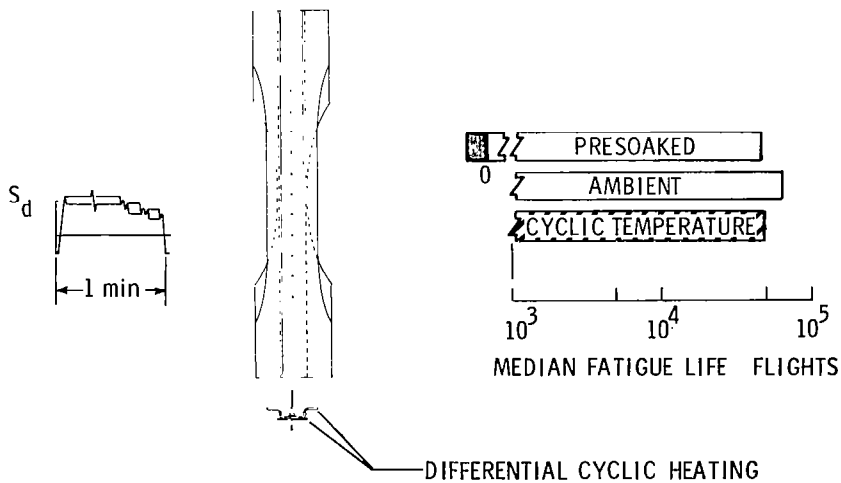
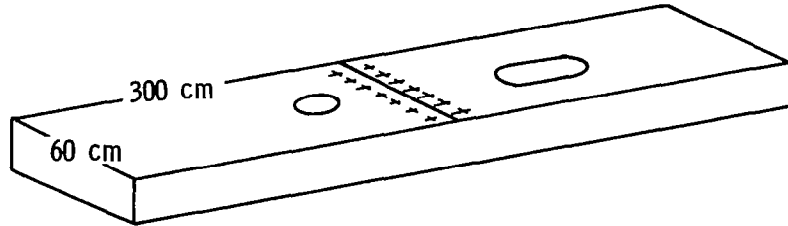

Figure 6.- Boeing accelerated fatigue tests (ref. 20).  
 MA Ti-6Al-4V sheet; gross-area one-g design stress  
 $S_d = 207$  MPa.



TESTS OF RIVETED ,  
SPOTWELDED, AND  
FUSION-WELDED BOX  
COVERS

LOADING	TEMPERATURE
CA 172 , -86	300 K
CA 240 ± 43	560 K
FBF/BLOCK , $S_d = 172$	300 K/560 K

RESULTS

- CONSTANT AMPLITUDE TESTS OF RIVETED AND SPOTWELDED COVERS IDENTIFIED FAILURE LOCATIONS OF SPECTRUM TESTS; BUT NO CORRELATION FOR FUSION-WELDED COVERS
- ADEQUACY OF CONSTANT AMPLITUDE TESTS TO IDENTIFY CRITICAL FAILURE LOCATIONS DEPENDED ON METHOD OF FABRICATION

Figure 7.- LTV fatigue tests of box beams (refs. 21 and 22).  
Ti-8Al-1Mo-1V; gross area one-g design stress  $S_d = 172$  MPa.

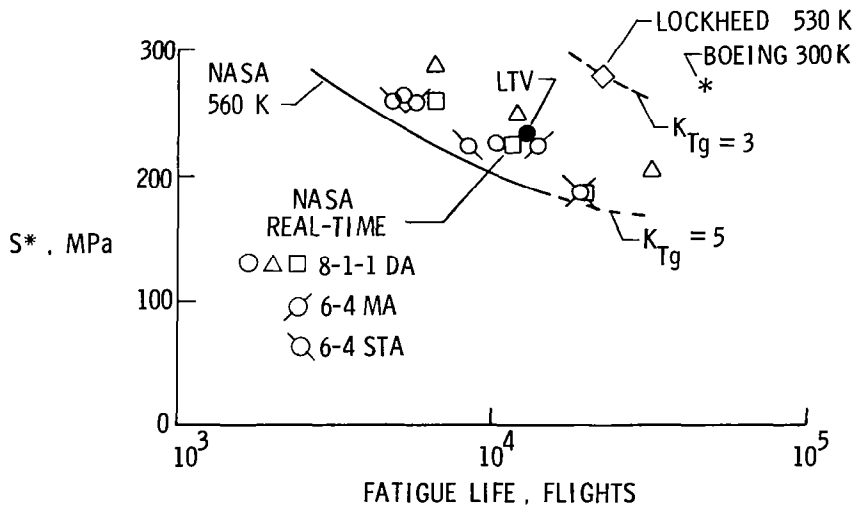

Figure 8.- Summary of coupon and component fatigue tests with specimen loads.