

DEVELOPMENTS IN STEADY AND UNSTEADY AERODYNAMICS

FOR USE IN AEROELASTIC ANALYSIS AND DESIGN

E. Carson Yates, Jr., and Samuel R. Bland
NASA Langley Research Center

SUMMARY

A review is given of seven research projects which are aimed at improving the generality, accuracy, and computational efficiency of steady and unsteady aerodynamic theory for use in aeroelastic analysis and design. These projects indicate three major thrusts of current research efforts: (1) more realistic representation of steady and unsteady subsonic and supersonic loads on aircraft configurations of general shape with emphasis on structural-design applications, (2) unsteady aerodynamics for application in active-controls analyses, and (3) unsteady aerodynamics for the frequently critical transonic speed range. The review of each project includes theoretical background, description of capabilities, results of application, current status, and plans for further development and use.

INTRODUCTION

Aeroelastic problems that are encountered in the analysis and design of high-performance aircraft such as supersonic cruise aircraft require consideration of structures and dynamics, as well as aerodynamics of lifting surfaces, control surfaces, and complete aircraft at subsonic, transonic, and supersonic speeds and for steady, oscillatory, and general unsteady motion. Among the technical disciplines involved (i.e., structures, dynamics, and aerodynamics), aerodynamics has always been in the least satisfactory state and has received the greatest emphasis in aeroelastic research and study. Moreover, the development of computer-aided design technology in recent years has imposed even more stringent requirements for comprehensive, accurate, and efficient aerodynamic tools inasmuch as many aerodynamic and aeroelastic analyses must be performed in the repetitive process of designing a minimum-mass aircraft structure that will satisfy a variety of design requirements such as strength, buckling, minimum gage, and aeroelastic requirements such as prescribed minimum flutter speed. (See, e.g., refs. 1 to 3.) In addition to flutter, other static and dynamic aeroelastic characteristics must be assessed. The former include load distribution and associated structural deformation, control effectiveness and reversal, and divergence, whereas the latter include response to gusts, turbulence, control transients, engine failure, and active control systems for the suppression of one or more of these responses.

High-performance, low-load-factor airplanes, such as supersonic cruise aircraft, are usually stiffness-critical to a significant degree. Since mass added to provide required stiffness can be a sizable fraction of payload (refs. 4 to 9), it is essential that it be accurately predictable during the design process. The aeroelastic calculations required for this purpose will, of course, be no more accurate than the aerodynamics used in them.

Requirements for the formulation and use of aerodynamics in aeroelastic analysis and design are in several respects more complicated and more severe than for the more conventional steady-state aerodynamics. For example: (1) The aeroelastician deals with flexible structures so that even in steady-state conditions, the aerodynamic load is a function of structural deformation, and vice versa. (2) The unsteady aerodynamic formulations required in dynamic aeroelasticity involve complex quantities (e.g., velocities, aerodynamic influence functions, and pressure) that manifest time- or frequency-dependent attenuations and phase shifts relative to steady state. (3) In dynamic aeroelasticity - flutter, for example - the aeroelastician must evaluate pressure distributions for vibration mode shapes that are much more wiggly than a typical steady-state mean-camber surface. The corresponding pressure distributions will also be more wiggly than those for steady state so that computational convergence requirements are usually more severe than for steady state. (4) Flutter analyses, as well as iterative structural resizing, require evaluation of pressure distributions for a multiplicity of mode shapes, frequencies, aircraft loading conditions, etc. Consequently, computational efficiency is vital, and it is essential to minimize the amount of recomputation required when mode shapes and/or frequencies are changed.

This paper reviews seven research projects, sponsored by the Langley Research Center, which should help to provide the capabilities in steady and unsteady aerodynamics needed for the aeroelastic analysis and design of high-performance aircraft such as supersonic cruise aircraft. These projects fall into three general categories which indicate the major thrusts of current research efforts: (1) more realistic representation of steady and unsteady subsonic and supersonic loads on aircraft configurations of general shape with emphasis on structural-design applications, (2) unsteady aerodynamics for application in active-controls analyses, and (3) unsteady aerodynamics for the frequently critical transonic speed range. The present review includes theoretical background, description of capabilities, results of application, current status, and plans for further development and use.

SYMBOLS

a_{∞}	free-stream speed of sound
C_L	lift coefficient
C_m	pitching-moment coefficient

C_N	normal-force coefficient
c_n	section normal-force coefficient
C_p	pressure coefficient
ΔC_p	lifting-pressure coefficient
k	reduced frequency
LE,TE	leading edge, trailing edge
M_∞	free-stream Mach number
M_L	local Mach number
s	Laplace-transform variable, i.e., motion exponential (real part defines motion envelope; imaginary part is reduced frequency)
T	thickness ratio
t	time
U	free-stream speed
x,y,z	streamwise, spanwise, and vertical Cartesian coordinates, respectively
α	angle of attack
$\dot{\alpha}$	time rate of change of angle of attack
α_0	initial angle of attack
γ	ratio of specific heats
δ	control-surface deflection angle
δ_{jh}	Kronecker delta
ξ,η	dummy variables for x and y , respectively
Φ	perturbation velocity potential
ϕ	steady-state part of perturbation velocity potential
φ	unsteady part of perturbation velocity potential
ω	frequency

ANALYSIS METHODS

The analysis methods being developed in connection with the seven research projects mentioned previously are listed in table 1, along with an indication of the relevance of each to the three general categories of current research interest, i.e., loads for use in structural design, aerodynamics for active-controls analyses, and aerodynamics for the transonic speed range. With the exception of "transonic aerodynamics for oscillating wings with thickness," all the methods are applicable to the steady-state limit condition. In table 1, the word "Present" indicates applicability of the method in its current state of development; whereas "Future" indicates capability that is still under development.

General Unsteady Compressible Potential Aerodynamics

Objective.— The primary objective of this development (refs. 10 to 19) is an accurate, general, unified method for calculating steady and unsteady loads on complete aircraft with arbitrary shape and motion in subsonic and supersonic flow. Emphasis is on efficient application in aeroelastic analyses (including active-controls analyses) and in computer-aided structural design.

Approach.— Green's theorem has been used to formulate the exact integral equation for the perturbation velocity potential Φ at an arbitrary point (x, y, z) in the fluid at time t in terms of the potential and its derivatives on the fluid boundary (ref. 10).

$$\begin{aligned} \Phi(x, y, z, t) = & \iiint\!\!\!\int GF \, dV_1 \, dt_1 + \iiint [\nabla_1 S \cdot (G\nabla_1 \Phi - \Phi\nabla_1 G) \\ & - \frac{1}{a_\infty^2} \frac{dS}{dt_1} (G \frac{\partial \Phi}{\partial t_1} - \Phi \frac{\partial G}{\partial t_1})] |\square S|^{-1} \, dS \, dt_1 \end{aligned} \quad (1)$$

where

G is Green's function (subsonic or supersonic source potential)

F represents nonlinear terms (products of derivatives of potential)

$S(x_1, y_1, z_1, t_1) = 0$ defines the body surface, and

$$|\square S| = \sqrt{S_{x_1}^2 + S_{y_1}^2 + S_{z_1}^2 + S_{t_1}^2}$$

S_{x_1} , S_{y_1} , S_{z_1} , and S_{t_1} are derivatives of S with respect to the subscript variable. The quadruple integral extends over the entire fluid volume; whereas, the triple integral extends over the surface bounding the fluid, i.e., the body surface, since disturbances must vanish at infinity. To find the potential

and hence the pressure at a point (x,y,z) on the body surface, equation (1) is used in conjunction with the exact boundary conditions and the Bernoulli equation. Note that no small-perturbation assumption has been made. The present computer program SOUSSA (Steady, Oscillatory, and Unsteady Subsonic and Supersonic Aerodynamics), however, does not include the nonlinear terms represented by the quadruple integral in equation (1).

Solution of equation (1) is by spatial discretization with arbitrary nonplanar quadrilateral surface panels and time solution by Laplace transform (ref. 16). The resulting set of simultaneous equations for the potential at a finite number of points on the body surface in terms of the normalwash at the surface can be expressed as

$$\begin{bmatrix} \tilde{Y}_{jh} \end{bmatrix} \begin{Bmatrix} \tilde{\Phi}_h \end{Bmatrix} = \begin{bmatrix} \tilde{Z}_{jh} \end{bmatrix} \begin{Bmatrix} \tilde{\Psi}_h \end{Bmatrix} \quad (2)$$

where

$$\begin{aligned} \tilde{\Phi}_h & \text{ is Laplace transform of perturbation velocity potential} \\ \tilde{\Psi}_h & \text{ is Laplace transform of normalwash at body surface} \\ \tilde{Y}_{jh} & = \delta_{jh} - (C_{jh} + sD_{jh})e^{-s\Theta_{jh}} \\ & \quad - \sum_n (F_{jn} + sG_{jn})S_{nh} e^{-s(\Theta_{jn} + \pi_n)} \\ \tilde{Z}_{jh} & = B_{jh} e^{-s\Theta_{jh}} \end{aligned} \quad (3)$$

Θ_{jh} and π_n are lag functions, S_{nh} is ± 1 depending on which side of the wake the point is on,

and

$$\begin{aligned} B_{jh} & = \frac{-1}{2\pi} \iint_{\Sigma_B} N_h \frac{1}{R} d\Sigma_B & C_{jh} & = \frac{1}{2\pi} \iint_{\Sigma_B} N_h \frac{\partial}{\partial N} \left(\frac{1}{R}\right) d\Sigma_B \\ D_{jh} & = \frac{-1}{2\pi} \iint_{\Sigma_B} N_h \frac{1}{R} \frac{\partial R}{\partial N} d\Sigma_B & F_{jh} & = \frac{1}{2\pi} \iint_{\Sigma_W} L_h \frac{\partial}{\partial N} \left(\frac{1}{R}\right) d\Sigma_W \\ G_{jh} & = \frac{-1}{2\pi} \iint_{\Sigma_W} L_h \frac{1}{R} \frac{\partial R}{\partial N} d\Sigma_W \end{aligned} \quad (4)$$

where

Σ_B and Σ_W indicate integration over body and wake surfaces, respectively,

$N_h(x,y,z)$ and $L_h(x,y,z)$ are shape functions,

R is elliptic ($M_\infty < 1$) or hyperbolic ($M_\infty > 1$) distance between influenced and influencing points, and

N is direction normal to body or wake surface.

Note that the integrals in equations (4) are independent of deformation or mode shape and are also independent of the transform variable s (and hence frequency in the oscillatory case). Consequently, these integrals need to be evaluated only once for a given Mach number unless the paneling arrangement is changed. Moreover, \tilde{Y}_{jh} and \tilde{Z}_{jh} are also independent of deflection shape and contain only simple functions of the transform variable. Hence, equation (2) can be solved efficiently for a variety of deflection shapes and frequencies. For example, adding modes in a flutter analysis or changing modes in structural design requires alteration only of the normalwash matrix in equation (2) and does not require reevaluation of the coefficient matrices $[\tilde{Y}_{jh}]$ and $[\tilde{Z}_{jh}]$.

A further advantage of this method results from use of arbitrary non-planar quadrilateral surface panels. If desired, the aerodynamic paneling can exactly fit a structural finite-element paneling arrangement so that interpolations between structural model and aerodynamic model can be minimized or avoided.

This formulation provides a unified surface-panel method for arbitrary motion of complete aircraft in subsonic and supersonic flow in which bodies, stores, lifting surfaces, and control surfaces are all paneled alike, i.e., with source panels having strength proportional to normalwash (usually specified) and doublet panels having strength proportional to Φ obtained by solution of equation (2).

Status.— The final version of the proof-of-concept computer program has been completed and is being documented as an interim SOUSSA code. Its capabilities are indicated in figure 1. An intermediate form of SOUSSA is also being used in FCAP (Flight Controls Analysis Program) (refs. 20 and 21) which is being developed primarily for analysis and synthesis of active control systems.

The interim SOUSSA program, in effect, solves the linearized velocity-potential equation with exact boundary conditions. The current development effort is directed primarily toward adaptation of SOUSSA for application in the transonic range. Several approaches are being pursued to incorporate the dominant effects of the nonlinear character of transonic flow without requiring brute-force numerical evaluation of the volume integral in equation (1).

Inclusion of the nonlinear influence of wake deformation in subsonic flow has also been demonstrated (ref. 17).

The interim SOUSSA program uses constant-potential (zeroth-order) surface elements which were adequate for demonstration of capability. However, a dominant objective throughout this work has been to use elements sophisticated enough to converge solutions for complicated shapes and motions with a number of elements small enough for the solution to be computationally tractable and economical. Consequently, higher order elements are being developed, along with special elements that have potential distributions which are appropriate for paneling adjacent to normalwash discontinuities such as at control-surface hinge lines and edges.

Reference 22 presents a finite-element approach to the analysis of rotational flow. The method is still under development. In combination with SOUSSA, it may offer a means for representing viscous-flow influence.

Applications.- Figure 2 (reproduced from ref. 18) shows the magnitude and phase angle of supersonic lift coefficient for an oscillating rectangular wing. Results are shown for converging, diverging, and harmonic oscillation. The latter are in good agreement with results from the acceleration-potential lifting-surface method of Laschka (ref. 23).

Figure 3 (also from ref. 18) shows chordwise pressure distribution on the wing of a wing-body-tail configuration in a diverging oscillation in incompressible flow. For simplicity in this demonstration calculation, both wing and tail have been taken to be rectangular with aspect ratio 6 and thickness ratio 0.09. No comparable calculations are available for comparison.

Plans*.- The additional capabilities that are under current development (fig. 1) will be incorporated into SOUSSA as they become available. Several approximations that were employed for computational expediency in the development program will be eliminated or revised in order to improve the accuracy, efficiency, and generality of the method. These broadened capabilities and improvements will also be incorporated into a modular "production" program SOUSSA that will be structured for efficient application to large-order flutter analysis and design problems.

SOUSSA aerodynamics will be combined with the SPAR finite-element structural-analysis program (ref. 24) and with the WIDOWAC structural-optimization program (refs. 1 to 3) in order to produce an efficient program PARS (Program for Analysis and Resizing of Structures) for generating minimum-mass structures for complete aircraft that will satisfy a number of static and dynamic structural and aeroelastic design requirements such as multiple flutter-speed constraints. FCAP (refs. 20 and 21) may eventually be used in combination with PARS for design of structures for aircraft with active control systems.

*All sections entitled "Plans" in this paper contain statements of current intentions. These, of course, are subject to change as time progresses.

Thus, SOUSSA will find application in flutter analyses, in active-controls analyses, and in computation of static and dynamic loads for computer-aided structural design.

Subsonic Kernel-Function Analysis for Wings With Oscillating Controls

Objective.- The objective of this work is accurate representation of the pressure distribution on lifting surfaces with oscillating leading-edge and trailing-edge controls. Emphasis is on applications to flutter analyses and active-controls studies.

Approach.- The well-known kernel-function analysis of reference 25 provides an integral equation representation of the linear potential equation for harmonic oscillations of a thin lifting surface. This equation

$$\frac{w(x,y)}{U} = \iint_S \Delta C_p(\xi,\eta) K(M_\infty, k, \xi-x, \eta-y) d\xi d\eta \quad (5)$$

relates the known downwash velocity $w(x,y)$ at a point on the surface to the unknown lifting pressure distribution $\Delta C_p(\xi,\eta)$. The kernel function K is defined by a singular integral. The integration region S includes only the wing surface. This integral equation is solved by the procedure of reference 26 as follows: The unknown pressure distribution is expanded in a series of known functions θ_n with unknown coefficients a_n as

$$\Delta C_p(\xi,\eta) = \sum_{n=1}^N a_n \theta_n(\xi,\eta) \quad (6)$$

The functions θ_n are chosen to satisfy the known edge conditions on the lifting surfaceⁿ (e.g., the Kutta condition at the trailing edge). Equation (6) is substituted into equation (5) and the integration performed for a set of N points (x_i, y_i) at which the downwash is known from the boundary condition. The resulting set of N simultaneous linear equations is then solved for the coefficients a_n .

Recent research (refs. 27 to 30) has provided an improved kernel-function procedure for wings with leading- and/or trailing-edge controls. In linear potential flow, the surface slope discontinuity at a control-surface hinge line or side edge leads to a downwash discontinuity which causes a logarithmic singularity in the lifting pressure at the hinge line and a $y \log y$ type variation in lifting pressure at the control surface edge (y measured from the control edge). The present method treats these singularities meticulously by using a set of pressure functions θ_n containing appropriate logarithmic terms. Within the framework of thin-wing theory, this kernel-function method provides the most accurate treatment of control-surface aerodynamics currently

available to the aeroelastician.

Status.- Program refinements and delivery should be completed in 1976.

Application.- An example of the results obtainable is shown in figure 4 (taken from ref. 27). The calculated lifting pressure distributions on a swept wing with oscillating partial-span control are compared with the experiment of reference 31. The agreement is excellent except near the control edges--the analysis treats the edge gaps as sealed.

Plans.- No further development is contemplated. The completed computer program will be used in studies of active control systems.

Unsteady Loads on Lifting Surfaces with Sharp-Edge Separation

Objective.- The objective of this development (refs. 32 to 38) is accurate evaluation of steady and unsteady aerodynamic loads on lifting surfaces of general shape at moderate to high angles of attack. Emphasis is on representations of structural design loads and flutter aerodynamics for high-load-factor conditions that are more realistic than those obtained from linearized (small disturbance) aerodynamic theory.

Approach.- Sharp edges are assumed in order to fix the location of flow separation. Kutta condition is imposed along all edges on which separation occurs. No assumptions of small perturbations are involved. A vortex model is established in which a mean-camber surface (or alternatively, wing upper and lower surfaces) of arbitrary shape is overlaid with a vortex grid from which discrete free vortices extend into the fluid across all edges on which separation occurs. The vortices are constrained to cross perpendicular to wing edges in order to satisfy the Kutta condition. The shape of each free vortex is approximated by a sequence of contiguous straight-line segments. The requirement that the free vortex system be force-free is satisfied approximately by alining each free vortex segment with the local flow velocity at one point along its length. Solution is by Biot-Savart law which is imposed in conjunction with an assumed position of the free vortices and exact normalwash boundary conditions on the mean-camber (or wing) surface in order to calculate the strengths of the bound vortices. After these strengths have been determined, Biot-Savart law is employed iteratively to find a new force-free location of the free vortices. The process is repeated until convergence tests are satisfied.

Status.- Current computer programs calculate steady load distributions and flow field for nonplanar and interfering lifting surfaces with flow separation from sharp leading edges, tips, and trailing edges, and also for general unsteady motion of lifting surfaces with separation from tips and trailing edges. Unsteady capability is currently being extended to include leading-edge separation. In figure 5, the present models are compared with the previously used flat-wake model of Belotserkovskii (ref. 39) and the incompressible-flow model of Djojodihardjo and Widnall (ref. 40) which accounts only for vorticity issuing from the trailing edge.

As presently formulated, compressibility is accounted for approximately by a Prandtl-Glauert type transformation which is based on the linearized potential-flow equation. The present problem becomes approximately linear, and hence this type of transformation becomes reasonable only when either Mach number or flow perturbation (e.g., angle of attack) is small. Comparisons of steady-state calculated lift and pitching moment with experimental values for several wings at several Mach numbers (e.g., ref. 35) have indicated that the present procedure gives good results for angles of attack (in degrees) up to at least $20\sqrt{1 - M_\infty^2}$. Use of local Mach number instead of free-stream Mach number in the transformation may extend the usefulness of the method to higher angles of attack in the middle-to-upper subsonic range.

Current activity is concerned with the effect of several internal parameters (e.g., vortex grid spacing, length of free vortex segments, etc.) on convergence of the calculations. In addition, artificial viscosity is being incorporated as a means of avoiding erratic behavior when vortices come close together, although this has not been a problem up to this time. Also, vorticity distribution functions are being investigated as a possible means for improving the efficiency of the calculations.

Applications.- Figure 6 (taken from ref. 36) shows a typical calculated vortex flow pattern around the tip of a rectangular wing. Only a coarse grid pattern is shown here for clarity. Figure 7 (also from ref. 36) shows the vorticity pattern for the same wing at the end of a ramp-type increase in angle of attack from 11° to 15° . Figure 8 (taken from ref. 38) illustrates lift lag as angle of attack is increased from 11° to 15° and conversely decreased from 15° to 11° . Figure 9 (from ref. 35) presents calculated spanwise load distributions for a rectangular wing in comparison with values calculated by linear theory and with experimental values. The large increase in load intensity, particularly near the tip, has significant implications for the structural designer since aircraft design loads occur at large angle-of-attack (limit load factor) conditions. Finally, figure 10 (from ref. 35) shows calculated normal force and pitching moment for a swept wing and includes comparisons with linear-theory results and with experiment.

Plans.- Pertinent results from the previously described current study will be incorporated into the computer program to improve its efficiency and generality. The program will be used to calculate aerodynamic characteristics, stability derivatives, and structural loads for several wing and wing-tail configurations, including deflected and deflecting control surfaces, and for the arrow-wing SCAR configuration. Generalized aerodynamic forces will be generated for flutter calculations to determine the effect of sharp-edge flow separation on flutter boundaries at moderate to high angles of attack. The changes in steady-state load distribution caused by edge separation indicate that the effect on flutter is probably detrimental. Note that linearized theory predicts no effect on flutter of angle of attack, twist, camber, or thickness.

Finite-Difference Method for Oscillating Transonic Flow

Objective.— The objective of this work is accurate solution of the transonic small-perturbation potential equation for harmonic oscillation. Current emphasis is on accurate "benchmark" type calculations that can serve as a standard for assessing the accuracy of approximate methods that are computationally more economical.

Approach.— Many aeroelastic problems, flutter in particular, are most severe in the transonic speed regime. In contrast with the steady transonic potential-flow problem which is inherently nonlinear, it is possible to linearize the unsteady problem and decouple it from the steady problem if oscillation frequencies are sufficiently high. Reference 41 presents many such linear-theory solutions in detail. Unfortunately, this linearization is not generally possible for accurate aeroelastic calculations at the low to moderate frequencies that are of usual interest and in the presence of varying local flow velocity and shock waves which characterize transonic flow.

The simplest equation which can properly describe the essential features of the flow is the transonic small-disturbance potential equation

$$\left[1 - M_\infty^2 - (\gamma + 1)M_\infty^2\phi_x - (\gamma - 1)\frac{M_\infty^2}{U}\phi_t \right] \phi_{xx} + \phi_{yy} + \phi_{zz} - 2\frac{M_\infty^2}{U}\phi_{xt} - \frac{M_\infty^2}{U^2}\phi_{tt} = 0 \quad (7)$$

Subscripts x, y, z, and t indicate derivatives of the potential with respect to the subscript variable. The nonlinear terms involving ϕ_x and ϕ_t are retained because they are of the same order as $1 - M_\infty^2$. It is possible to effect a linearization for the unsteady flow by expressing the perturbation potential ϕ as a sum of steady and unsteady parts

$$\phi(x,y,z,t) = \phi(x,y,z) + \varphi(x,y,z)e^{i\omega t} \quad (8)$$

where harmonic motion has been assumed. It is further assumed that the unsteady motion is a small perturbation of the mean, steady flow so that $\varphi \ll \phi$. Substitution of equation (8) into equation (7) leads to a partial separation of the steady and unsteady flow effects. The usual small-perturbation equation results for the mean steady flow

$$\left[1 - M_\infty^2 - (\gamma + 1)M_\infty^2\phi_x \right] \phi_{xx} + \phi_{yy} + \phi_{zz} = 0 \quad (9)$$

and the equation for unsteady flow is

$$\left[1 - M_\infty^2 - (\gamma + 1)M_\infty^2\phi_x\right]\phi_{xx} + \phi_{yy} + \phi_{zz} - M_\infty^2 \left[12k + (\gamma + 1)\phi_{xx}\right]\phi_x + M_\infty^2 \left[k^2 - i(\gamma - 1)k\phi_{xx}\right]\phi = 0 \quad (10)$$

This is a linear equation for the unsteady potential ϕ . However, the equation has nonconstant coefficients which depend on the mean, steady flow potential ϕ . Equation (10) is of the same type as equation (9); that is, the unsteady-flow problem is elliptic (subsonic) or hyperbolic (supersonic) at any point in accordance with the character of the mean, steady flow at that point.

There is current interest in a variety of attacks on the unsteady transonic flow problem. The significant successes of finite-difference methods for steady flow led to the application of these methods to the unsteady flow problem. Some of this research is reported in references 42 to 45. In the present procedure, the steady flow equation (9) is first solved on a rectangular finite-difference mesh. The unsteady equation (10) is then solved on the same mesh using values from the steady solution to provide the values of the nonconstant coefficients required at the mesh points. The large system of algebraic equations (one for each mesh point) is solved by a relaxation procedure. Central differences are used in subsonic portions of the flow, and backward differences are used in supersonic portions.

Status.- Initial calculations have been made for several airfoils and for a pitching rectangular wing. However, numerical difficulties have imposed an upper limit on frequency that becomes more severe as free-stream Mach number approaches 1.0. Work is still in progress.

Application.- The results of the first application of this method to a three-dimensional flow problem (ref. 44) are given in figure 11. The real part of the lifting pressure for a rectangular wing oscillating in pitch is presented. There were 18 304 mesh points used. In general, the finite-difference calculation agrees well with the linear theory (uniform flow). However, the flow is supercritical, and a shock wave is evident over inboard portions of the wing in the finite-difference result (nonuniform flow).

Plans.- Development of this method will continue and should lead to a documented computer program for isolated lifting surfaces.

Although finite-difference methods have promise for providing accurate solutions to transonic-flow problems, the computational task is enormous in comparison with conventional lifting-surface or surface-paneling methods. Two approximate, but perhaps more widely useable methods are described in the following two sections. A discussion of several proposed methods is given in reference 46.

Transonic Aerodynamics for Oscillating Wings with Thickness

Objective.- The objective of this development (refs. 47 to 49) is an approximate method for calculating unsteady transonic aerodynamic forces that is more accurate than linear theory, especially in the range of reduced frequency that is of usual interest in lifting-surface flutter problems. Emphasis is on a method that accounts for the dominant effects of nonuniform mean flow and is at the same time theoretically and computationally suitable for use in flutter analyses.

Approach.- If local Mach number does not vary much from 1.0, the transonic equation for small-perturbation velocity potential can be written in terms of local Mach number

$$\varphi_{yy} + \varphi_{zz} - M_L^2(2ik\varphi_x - k^2\varphi) = 0 \quad (11)$$

As in the previous section, the unsteady perturbation is assumed to be small relative to the steady state so that local Mach number can be taken to be that for the mean steady flow. If the nonuniform coordinate transformation

$$\tilde{x} = x \quad \tilde{y} = M_L(x,y)y \quad \tilde{z} = M_L(x,y)z \quad (12)$$

is imposed, equation (11) becomes

$$\tilde{\varphi}_{\tilde{y}\tilde{y}} + \tilde{\varphi}_{\tilde{z}\tilde{z}} - 2ik\tilde{\varphi}_{\tilde{x}} + k^2\tilde{\varphi} = 0 \quad (13)$$

where $\tilde{\varphi}(\tilde{x}, \tilde{y}, \tilde{z}) = M_L(x,y)\varphi(x,y,z)$.

Equation (13) is a linear equation with constant coefficients and has exactly the same form as the conventional linearized unsteady transonic-flow equation. (See, e.g., ref. 41.) Solutions of the latter involve propagation of pressure disturbances along straight ray paths. The coordinate transformation (eq. (12)) therefore is equivalent to distorting the space so that ray paths that are curved in the physical space x,y,z are straightened out in the transformed space $\tilde{x}, \tilde{y}, \tilde{z}$. Consequently, the problem can be solved in the transformed space by any method that is suitable for the conventional linearized equation-- e.g., sonic kernel function (refs. 25 and 50) or sonic box (refs. 51 to 53). The latter method has been used for current implementation.

Figure 12 illustrates the distortion of wing planform caused by the coordinate transformation. If the transformation is to be single valued, equations (12) imply limitations on how rapidly Mach number can vary in a direction lateral to the free stream. Thus, shock waves must not impinge upon the wing. Another limitation on usefulness of this method is the requirement that a steady-state solution be available to provide local

Mach number values for the coordinate transformation.

Status.- The coordinate-transformation method has been demonstrated (refs. 47 to 49) by modification of the sonic box computer program (refs. 51 to 53). The accuracy, efficiency, and generality of the demonstration program is currently being improved. The final documented program should be available early in 1977.

Applications.- The method has been used to calculate aerodynamic parameters for several wings with finite thickness, and the results have been compared with calculations for zero thickness (conventional linear transonic theory) in references 47 and 48. The calculated detrimental effect of finite thickness on transonic flutter speed is illustrated in figure 13 (taken from ref. 47) for a 45° delta wing with elliptical cross section. For a 0.04 thickness-chord ratio, flutter speed is 15 percent below the zero-thickness value.

Plans.- The improved computer program will be documented and further evaluated by comparison of results with measured unsteady air forces and by application to transonic flutter analyses. Use of the coordinate transformation in conjunction with other linear-theory methods is contemplated.

Mixed Subsonic-Supersonic Kernel-Function Analysis for Oscillating Wings

Objective.- The objective of this effort (refs. 54 to 56) is an approximate method for calculating unsteady transonic aerodynamic forces that accounts for the presence of shock waves and the mixed subsonic-supersonic character of the flow. Emphasis is on a method that includes variations in local Mach number and is suitable for use in flutter analyses.

Approach.- The present method was synthesized by patching together linear subsonic and supersonic kernel-function analyses to simulate the mixed subsonic-supersonic character of transonic flow. The wing is divided into a few subsurfaces on which the flow is either subsonic or supersonic. Either subsonic or supersonic kernel-function aerodynamics, as appropriate, is used on each subsurface. In addition, the local Mach number is used at each collocation point. This method requires this mean (steady-flow) local Mach number as input from another source. A doublet singularity is included to represent the unsteady shock condition.

The mixed-flow method should be attractive to the aeroelastician since it is composed of methods which are generally familiar and which are relatively efficient computationally. However, extensive testing will be required to assess its limitations and reliability.

Status.- The computer program is being debugged and documented.

Application.- Measured and calculated pressure distributions for a wing oscillating in bending are shown in figure 14. The calculations are from reference 56; the measurements are from reference 57. The local Mach number

distribution, shown for a section near midsemispan, was used as input. The uniform-flow calculation (dash line) was carried out with the subsonic kernel function at $M_\infty = 0.997$. The mixed-flow calculation, which includes the shock condition, provides somewhat better agreement with experiment than the uniform-flow calculation.

Plans.- The method will be applied in transonic flutter calculations as time permits.

Oscillatory Supersonic Lifting-Surface Panel Method

Objective.- The objective of this effort is a general, linear-theory method for calculating supersonic aerodynamic forces on thin oscillating lifting surfaces with a panelling scheme that fits planform boundaries exactly and is independent of Mach number. Emphasis is on developing a method that is suitable for routine use in flutter analyses.

Approach.- This method is a reformulation of the work reported in references 58 to 61. The method is applicable to configurations of the type illustrated in figure 15. Each lifting surface (e.g., wing segment, vertical tail, control surface) is represented as a plane defined by the locations of its four corners. Each of these zero-thickness surfaces is panelled with parallelograms which have two edges parallel to the surface leading edge and two edges parallel to the free stream. As can be seen in the figure, this geometry must be adjusted at the surface trailing edge.

The analytical method is based on an integral equation solution of the linear potential equation for harmonic motion. The unknowns are the streamwise gradients of the jump in velocity potential across each panel. Within each panel, the velocity potential varies linearly in the streamwise direction and is constant in the spanwise direction. Specification of the downwash in each panel leads to a collocation solution for the unknown potential-gradient values.

This method should lead to an efficient procedure for applying linearized supersonic flow theory to thin lifting surfaces. It should be useful for flutter analyses and active-control analyses. It represents a significant advance over the earlier Mach box lifting-surface procedures.

Status.- A documented computer program should be available by the end of 1976.

Plans.-No additional development effort is contemplated.

CONCLUDING REMARKS

High-performance, low-load-factor airplanes, such as supersonic cruise aircraft, are usually stiffness-critical to a significant degree. Consequently,

to satisfy stiffness and aeroelastic stability requirements without undue mass penalty, it is essential that the static and dynamic aeroelastic characteristics and stiffness requirements of such aircraft be accurately and reliably assessable by efficient analytical means. Since the aerodynamic methods available for such purposes are in a much less satisfactory state than are the structures and dynamics techniques, considerable importance is placed upon improving the generality, accuracy, and computational efficiency of steady and unsteady aerodynamics.

This paper has reviewed seven research projects which indicate three major thrusts of current research efforts: (1) more realistic representation of steady and unsteady subsonic and supersonic loads on aircraft configurations of general shape with emphasis on structural-design applications, (2) unsteady aerodynamics for application in active-controls analyses, and (3) unsteady aerodynamics for the frequently critical transonic speed range. The projects reviewed herein should help to broaden significantly the aerodynamic capabilities available for aeroelastic analysis and design.

REFERENCES

1. Haftka, Raphael T.: Automated Procedure for the Design of Wing Structures to Satisfy Strength and Flutter Requirements. NASA TN D-7264, 1973.
2. Haftka, Raphael T.; and Starnes, James H., Jr.: WIDOWAC (Wing Design Optimization with Aeroelastic Constraints): Program Manual. NASA TM X-3071, 1974.
3. Haftka, Raphael T.; and Yates, E. Carson, Jr.: Repetitive Flutter Calculations in Structural Design. J. of Aircraft, vol. 13, no. 7, July 1976, pp. 454-461.
4. Sakata, I. F.; Davis, G. W.; Robinson, J. C.; and Yates, E. C., Jr.: Design Study of Structural Concepts for an Arrow-Wing Supersonic Cruise Aircraft. AIAA Paper 75-1037, 1975.
5. Sakata, I. F.; and Davis, G. W.: Evaluation of Structural Design Concepts for an Arrow-Wing Supersonic Cruise Aircraft. NASA CR-2667, 1976.
6. Sakata, I. F.; and Davis, G. W.: Substantiating Data for Arrow-Wing Supersonic Cruise Aircraft Structural Design Concepts Evaluation. NASA CR-132575, vols. 1 to 4, 1976.
7. Robinson, James C.; Yates, E. Carson, Jr.; Turner, M. Jonathan; and Grande, Donald L.: Application of an Advanced Computerized Structural Design System to an Arrow-Wing Supersonic Cruise Aircraft. AIAA Paper 75-1038, 1975.
8. Grande, D. L.; and Turner, M. J.: Study of Structural Design Concepts for an Arrow-Wing Supersonic Cruise Aircraft. NASA CR-2743, 1976.
9. Boeing Staff: Study of Structural Design Concepts for an Arrow-Wing Supersonic Transport Configuration. NASA CR-132576. vols. 1 and 2, 1976.
10. Morino, L.: A General Theory of Unsteady Compressible Potential Aerodynamics. NASA CR-2464, 1974. (Supersedes Boston University Report TR 72-01, June 1972).
11. Morino, L.: Unsteady Compressible Potential Flow Around Lifting Bodies: General Theory. AIAA Paper 73-196, 1973.
12. Kuo, C. C.; and Morino, L.: Steady Subsonic Flow Around Finite-Thickness Wings. NASA CR-2616, Nov. 1975.
13. Morino, L.; and Kuo, C. C.: Unsteady Subsonic Compressible Flow Around Finite Thickness Wings. AIAA Paper 73-313, March 1973.
14. Morino, L.; and Kuo, C. C.: Subsonic Potential Aerodynamics for Complex Configurations: A General Theory. AIAA J., vol. 12, no. 2, Feb. 1974, pp. 191-197.

15. Morino, L.; Chen, L. T.; and Suciu, E. O.: Steady and Oscillatory Subsonic and Supersonic Aerodynamics Around Complex Configurations. AIAA J., Vol. 13, No. 3, March 1975, pp. 368-374.
16. Morino, L.; and Chen, L. T.: Indicial Compressible Potential Aerodynamics Around Complex Aircraft Configuration. In Aerodynamic Analyses Requiring Advanced Computers, NASA SP-347, Paper No. 38, 1975, pp. 1067-1110.
17. Suciu, E. O.; and Morino, L.: A Nonlinear Finite-Element Analysis of Wings in Steady Incompressible Flows with Wake Roll-up. AIAA Paper 76-64, 1976.
18. Tseng, K.; and Morino, L.: Fully Unsteady Subsonic and Supersonic Potential Aerodynamics of Complex Aircraft Configurations for Flutter Applications. Proceedings of the AIAA/ASME/SAE 17th Structures, Structural Dynamics, and Materials Conference, King of Prussia, PA., May 5-7, 1976.
19. Tseng, Kadin; and Morino, Luigi: A New Unified Approach for Analyzing Wing-Body-Tail Configurations with Control Surfaces. AIAA Paper No. 76-418, July 1976.
20. Noll, R. B.; and Morino, L.: FCAP-A New Tool for the Evaluation of Active Control Technology. AIAA Paper No. 75-1059, 1975.
21. Noll, R. B.; and Morino, L.: Flutter and Gust Response Analysis of Flexible Aircraft With Active Control. Proceedings of the AIAA/ASME/SAE 17th Structures, Structural Dynamics and Materials Conference, King of Prussia, Pa., May 5-7, 1976.
22. Morino, L.: A Finite Element Method for Rotational Incompressible Aerodynamics. Boston University, College of Engineering, TN-74-04, December 1974.
23. Laschka, B.: Zur Theorie der Harmonisch Schwingenden Tragenden Flache bei Unterschallstromung. Zeitschrift für Flugwissenschaften, 11 (1963), Heft 7, pp. 265-292.
24. Giles, Gary L.: Computer-Aided Methods for Analysis and Synthesis of SCAR Structures. Presented at the Supersonic Cruise Aircraft Research (SCAR) Conference, Hampton, Virginia, November 9-12, 1976.
25. Watkins, Charles E.; Runyan, Harry L.; and Woolston, Donald S.: On the Kernel Function of the Integral Equation Relating the Lift and Downwash Distributions of Oscillating Finite Wings in Subsonic Flow. NACA Rep. 1234, 1955.
26. Watkins, Charles E.; Woolston, Donald S.; and Cunningham, Herbert J.: A Systematic Kernel Function Procedure for Determining Aerodynamic Forces on Oscillating or Steady Finite Wings at Subsonic Speeds. NASA TR R-48, 1959.

27. Rowe, W. S.; Winther, B. A.; and Redman, M. C.: Prediction of Unsteady Aerodynamic Loadings Caused by Trailing Edge Control Surface Motions in Subsonic Compressible Flow - Analysis and Results. NASA CR-2003, June 1972.
28. Rowe, W. S.; Winther, B. A.; and Redman, M. C.: Unsteady Subsonic Aerodynamic Loadings Caused by Control Surface Motions. J. Aircraft, vol. 11, no. 1, Jan. 1974, pp. 45-54.
29. Rowe, W. S.; Sebastian, J. D.; and Redman, M. C.: Some Recent Developments in Predicting Unsteady Loadings Caused by Control Surface Motions. AIAA Paper 75-101, Jan. 1975.
30. Rowe, W. S.; Redman, M. C.; Ehlers, F. E.; and Sebastian, J. D.: Prediction of Unsteady Aerodynamic Loadings Caused by Leading Edge and Trailing Edge Control Surface Motions in Subsonic Compressible Flow - Analysis and Results. NASA CR-2543, 1975.
31. Försching, H.; Triebstein, H.; and Wagner, J.: Pressure Measurements on an Harmonically Oscillating Swept Wing with Two Control Surfaces in Incompressible Flow. Symposium on Unsteady Aerodynamics for Aeroelastic Analyses of Interfering Surfaces - Part II, AGARD CP-80-71, Apr. 1971.
32. Mook, D. T.; and Maddox, S. A.: Extension of a Vortex-Lattice Method to Include the Effects of Leading-Edge Separation. J. of Aircraft, vol. 11, no. 2, Feb. 1974, pp. 127-128.
33. Kandil, O. A.; Mook, D. T.; and Nayfeh, A. H.: Nonlinear Prediction of Aerodynamic Loads on Lifting Surfaces. AIAA Paper 74-503, June 1974, also in Journal of Aircraft, vol. 13, no. 1, January 1976, pp. 22-28.
34. Kandil, O. A.; Mook, D. T.; and Nayfeh, A. H.: Subsonic Loads on Wings Having Sharp Leading Edges and Tips. J. Aircraft, vol, 13, no. 1, Jan. 1976, pp. 62-63.
35. Kandil, O. A.: Prediction of the Steady Aerodynamic Loads on Lifting Surfaces Having Sharp-Edge Separation. Ph.D. Dissertation, Engineering Science and Mechanics Department, Virginia Polytechnic Institute and State University, December 1974.
36. Atta, E. H.: Unsteady Flow Over Arbitrary Wing-Planforms, Including Tip Separation. M.S. Thesis, Dept. of Engineering Science and Mechanics, Virginia Polytechnic Institute and State University, Mar. 1976.
37. Kandil, Osama A.; Mook, Dean T.; and Nayfeh, Ali H.: New Convergence Criteria for the Vortex-Lattice Models of the Leading-Edge Separation. Vortex-Lattice Utilization. NASA SP-405, 1976.
38. Atta, E. H.; Kandil, O. A.; Mook, D. T.; and Nayfeh, A. H.: Unsteady Flow over Wings Having Sharp-Edge Separation. Vortex-Lattice Utilization. NASA SP-405, 1976.

39. Belotserkovskii, S. M.: Gust Effects on Wings of Complex Planform at Subsonic Speeds. *Izv. ZN SSSR, Mekanika Zhidkosti i Gaza*, vol. 4, 1966, pp. 129-138.
40. Djojodihardjo, R. H.; and Widnall, S. E.: A Numerical Method for Calculation of Nonlinear Unsteady Lifting Potential Flow Problems. *AIAA Journal*, vol. 7, no. 10, Oct. 1969, pp. 2001-2009.
41. Landahl, Marten T.: *Unsteady Transonic Flow*. Pergamon Press, Inc., 1961.
42. Ehlers, F. Edward: A Finite Difference Method for the Solution of the Transonic Flow Around Harmonically Oscillating Wings. NASA CR-2257, 1974.
43. Ehlers, F. Edward: A Finite Difference Method for the Solution of the Transonic Flow Around Harmonically Oscillating Wings. AIAA Paper 74-543, June 1974.
44. Weatherill, Warren H.; Ehlers, F. Edward; and Sebastian, James D.: Computation of the Transonic Perturbation Flow Fields Around Two- and Three-Dimensional Oscillating Wings. NASA CR-2599, Dec. 1975.
45. Weatherill, Warren H.; Sebastian, James D.; and Ehlers, F. E.: On the Computation of the Transonic Perturbation Flow Fields Around Two- and Three-Dimensional Oscillating Wings. AIAA Paper 76-99, Jan. 1976.
46. Bland, Samuel R.: Recent Advances and Concepts in Unsteady Aerodynamic Theory. In *Aerodynamic Analyses Requiring Advanced Computers, Part II*, NASA SP-347, 1975, pp. 1305-1326.
47. Ruo, S. Y.; Yates, E. Carson, Jr.; and Theisen, J. G.: Calculations of Unsteady Transonic Aerodynamics for Oscillating Wings with Thickness. *Journal of Aircraft*, vol. 11, no. 10, Oct. 1974, pp. 601-608.
48. Ruo, S. Y.; and Theisen, J. G.: Calculation of Unsteady Transonic Aerodynamics for Oscillating Wings with Thickness. NASA CR-2259, June 1975.
49. Ruo, S. Y.: Calculation of Unsteady Transonic Aerodynamics for Oscillating Wings with Thickness (Computer Program). NASA CR-132477, Sept. 1974.
50. Runyan, Harry L.; and Woolston, Donald S.: Method for Calculating the Aerodynamic Loading on an Oscillating Finite Wing in Subsonic and Sonic Flow. NACA Rep. 1322, 1957.
51. Rodemich, E. R.; and Andrew, L. V.: Unsteady Aerodynamics for Advanced Configurations, Part II - A Transonic Box Method for Planar Lifting Surfaces. FDL-TDR-64-152, Part II, May 1965, Air Force Flight Dynamics Lab., Wright-Patterson Air Force Base, Ohio.

52. Olsen, J. J.: Demonstration of a Transonic Box Method for Unsteady Aerodynamics of Planar Wings. AFFDL-TR-66-121, Oct. 1966, Air Force Flight Dynamics Lab, Wright-Patterson Air Force Base, Ohio.
53. Stenton, T. E.; and Andrew, L. V.: Transonic Unsteady Aerodynamics for Planar Wings with Trailing Edge Control Surfaces. AFFDL-TR-67-180, Aug. 1968, Air Force Flight Dynamics Lab, Wright-Patterson Air Force Base, Ohio.
54. Cunningham, Atlee M., Jr.: The Application of General Aerodynamic Lifting Surface Elements to Problems in Unsteady Transonic Flow. NASA CR-112264, 1973.
55. Cunningham, Atlee M., Jr.: An Oscillatory Kernel Function Method for Lifting Surfaces in Mixed Transonic Flow. AIAA Paper 74-359, Apr. 1974.
56. Cunningham, Atlee M., Jr.: Further Developments in the Prediction of Oscillatory Aerodynamics in Mixed Transonic Flow. AIAA Paper 75-99, Jan. 1975.
57. Becker, J.: Vergleich gemessener und berechneter instationärer Druckverteilungen für den hohen Unterschall an einem elastischen gepfeilten Flügel. EWR-Bericht Nr. 403-69, Messerschmitt-Bolkow-Blohm, Sept. 1969.
58. Appa, Kari; and Smith, G. C. C.: Further Developments in Consistent Unsteady Supersonic Aerodynamic Coefficients. J. Aircraft, Vol. 9, No. 2, Feb. 1972, pp. 157-161.
59. Appa, Kari; and Smith, G. C. C.: Development and Application of Supersonic Unsteady Consistent Aerodynamics for Interfering Parallel Wings. NASA CR-2168, Aug. 1972.
60. Appa, Kari; and Smith, G. C. C.: Finite Element Supersonic Aerodynamics for Oscillating Parallel Wings. J. Aircraft, Vol. 11, No. 8, Aug. 1974, pp. 433-434.
61. Appa, Kari; and Jones, William P.: Integrated Velocity Potential Formulation of Unsteady Supersonic Aerodynamics for Interfering Wings. AIAA Paper 75-762, May 1975.

TABLE 1.- SUMMARY OF ANALYTICAL METHODS

Analysis method	Design loads	Active controls	Transonic range
General unsteady compressible potential aerodynamics (SOUSSA)	Present	Present	Future
Subsonic kernel-function analysis for wings with oscillating controls		Present	
Unsteady loads on lifting surfaces with sharp-edge separation	Present	Future	
Finite-difference method for oscillating transonic flow			Present
Transonic aerodynamics for oscillating wings with thickness			Present
Mixed subsonic-supersonic kernel-function analysis for oscillating wings			Present
Oscillatory supersonic lifting-surface panel method	Present	Present	

GENERAL SURFACE-PANEL METHOD:

- ARBITRARY COMPLETE A/C CONFIGURATION
- STEADY AND GENERAL UNSTEADY MOTION
- SUBSONIC AND SUPERSONIC
- COMPUTATIONAL EFFICIENCY

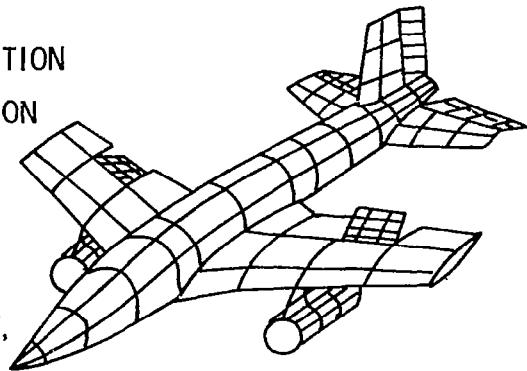

CURRENT DEVELOPMENTS:

- NONLINEAR EFFECTS (TRANSONIC FLOW, WAKE DEFORMATION)
- IMPROVED SURFACE ELEMENTS (HIGHER ORDER, SPECIAL PURPOSE)
- ROTATIONAL FLOW (TURBULENCE, VISCOSITY)

Figure 1.- Status of design-oriented potential-flow aerodynamics (SOUSSA).

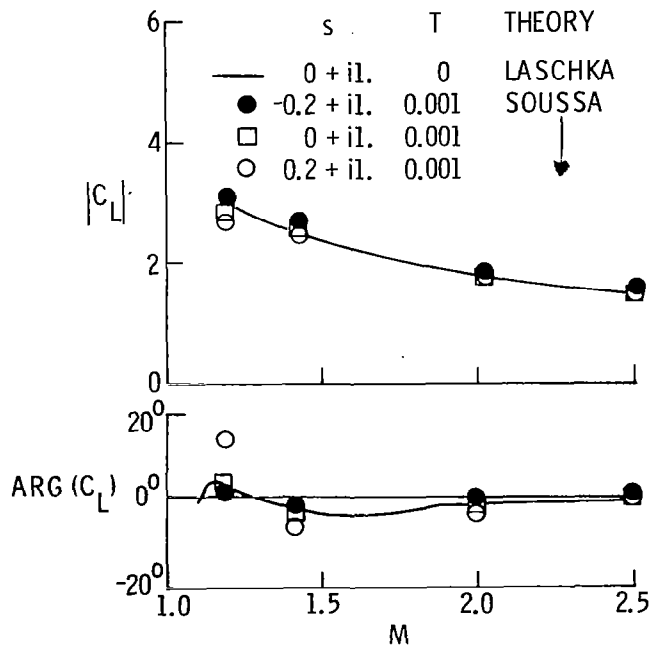

Figure 2.- Lift coefficient for aspect-ratio-2 rectangular wing oscillating in pitch.

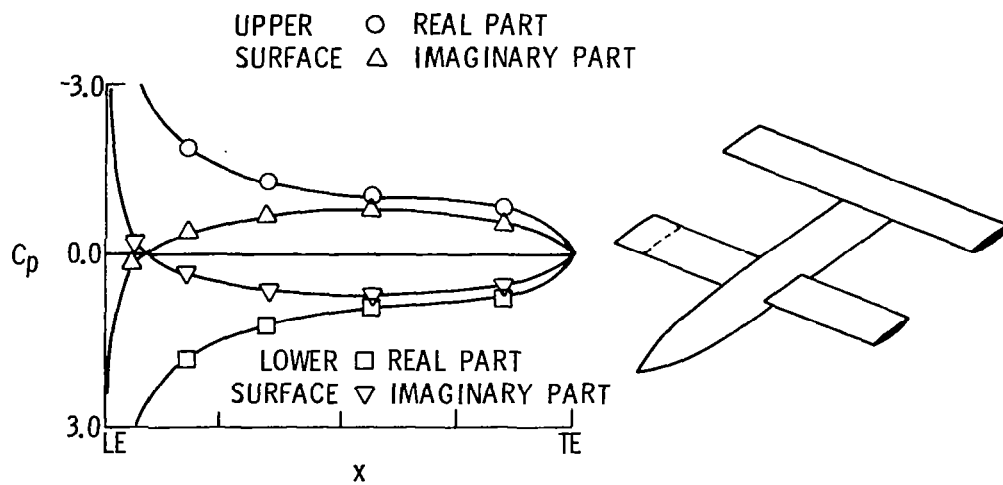
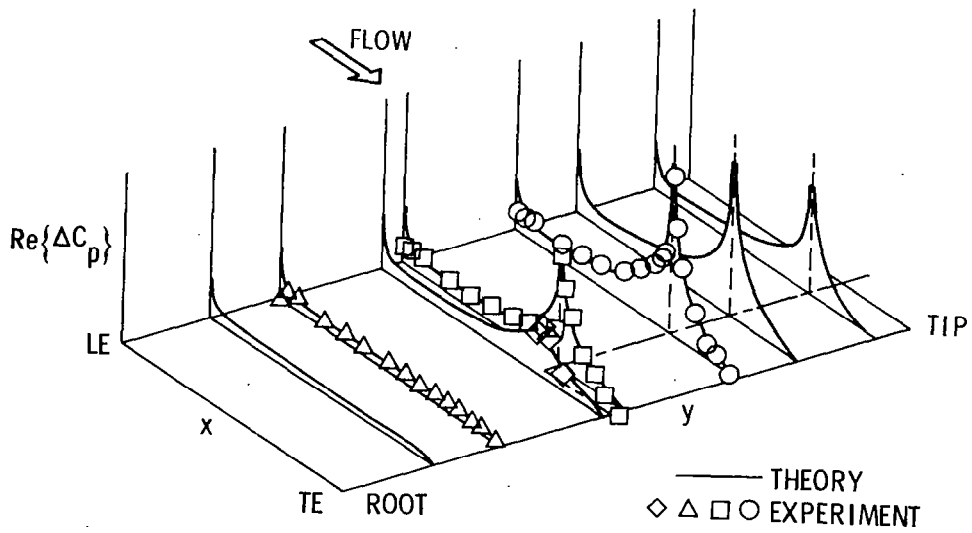
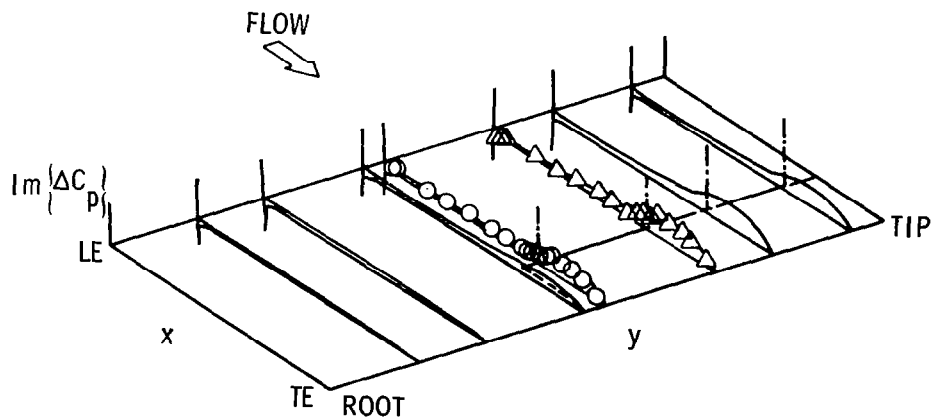

Figure 3.- Pressure distribution at wing spanwise station 0.78 on wing-body-tail in diverging pitch oscillation about wing midchord. $s = 0.1 + 11.5i$, wing and tail aspect ratio = 6.0, $T = 0.09$.



(a) Real part.



(b) Imaginary part.

Figure 4.- Lifting pressure distribution on swept wing with oscillating control surface. $M_\infty = 0$; $k = 0.372$; $\delta = 0.66^\circ$.

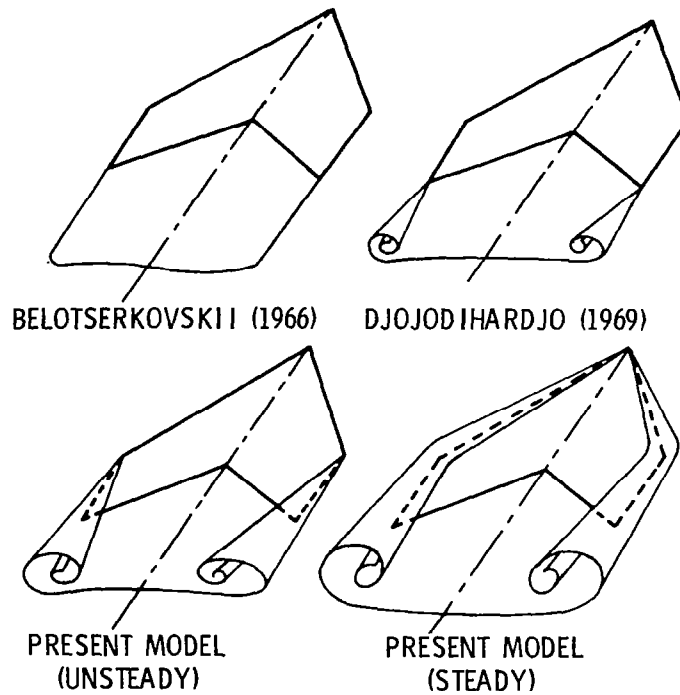

Figure 5.- Comparison of present models and previous models.

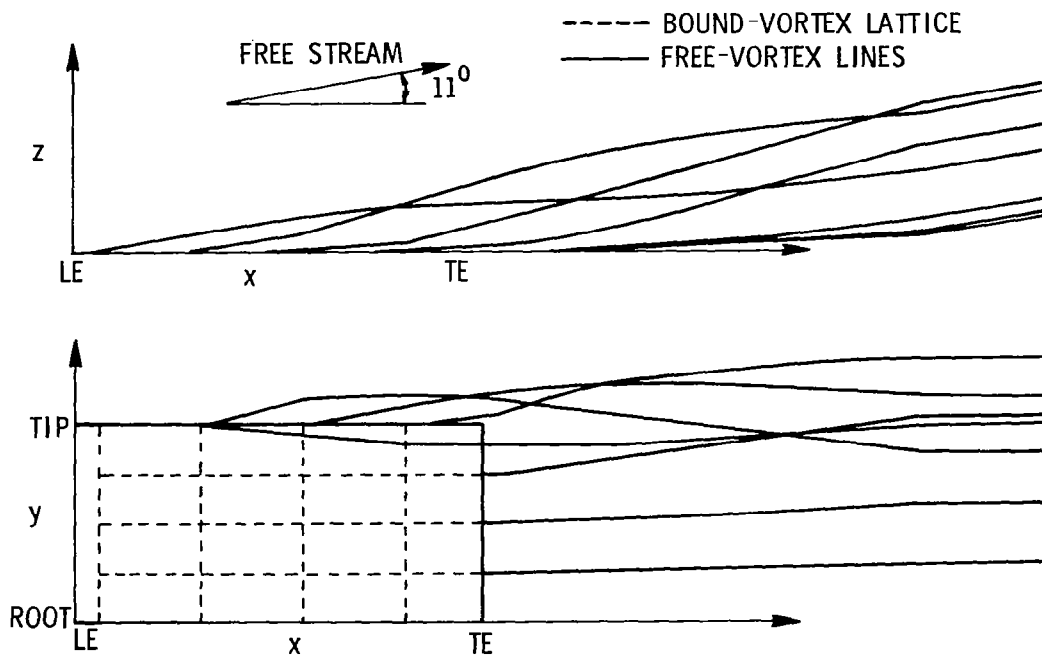

Figure 6.- Wake shape for aspect-ratio-1.0 rectangular wing in steady flow. $\alpha = 11^\circ$.

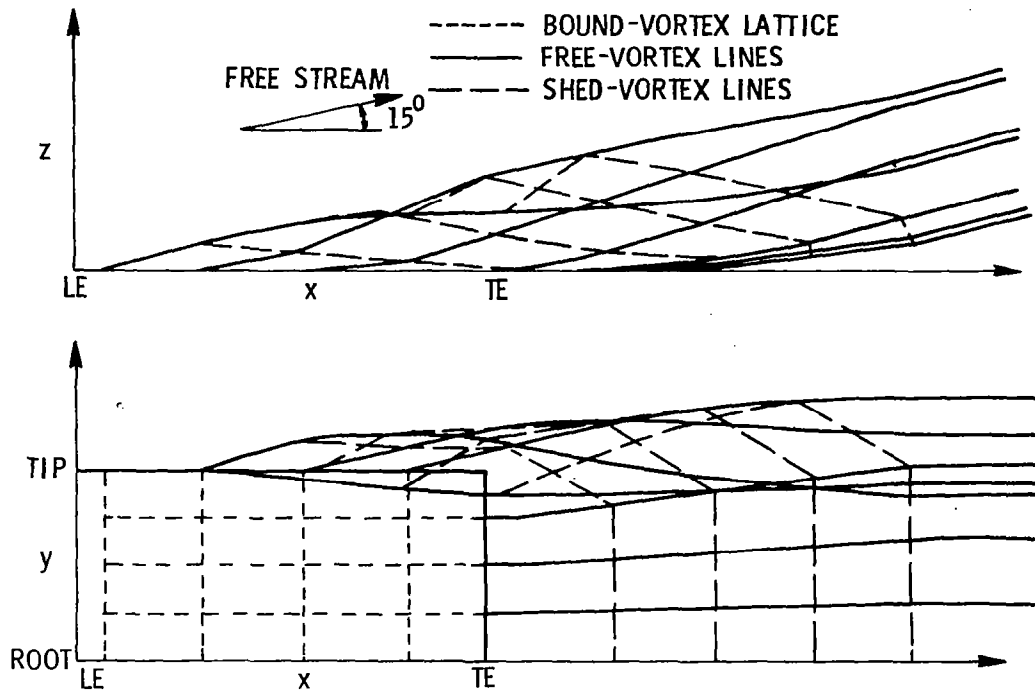

Figure 7.- Wake shape for aspect-ratio-1.0 rectangular wing in unsteady flow.
 $\alpha(t) = \alpha_0 + \dot{\alpha}t$; $\alpha_0 = 11^\circ$; $\dot{\alpha} = 1.0$; $t = 4$.

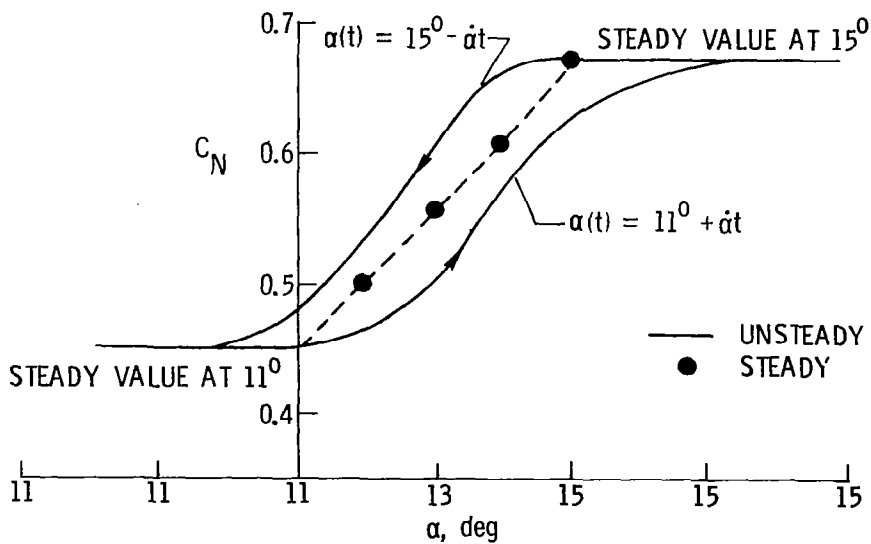

Figure 8.- Normal-force coefficient for aspect-ratio-1.0 rectangular wing in unsteady flow. $\dot{\alpha} = 1$.

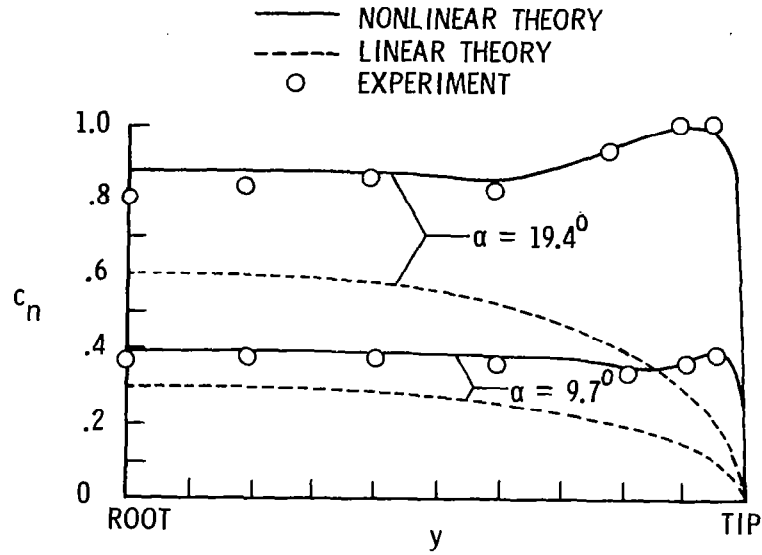

Figure 9.- Spanwise distribution of normal-force coefficient for aspect-ratio-1.0 rectangular wing.

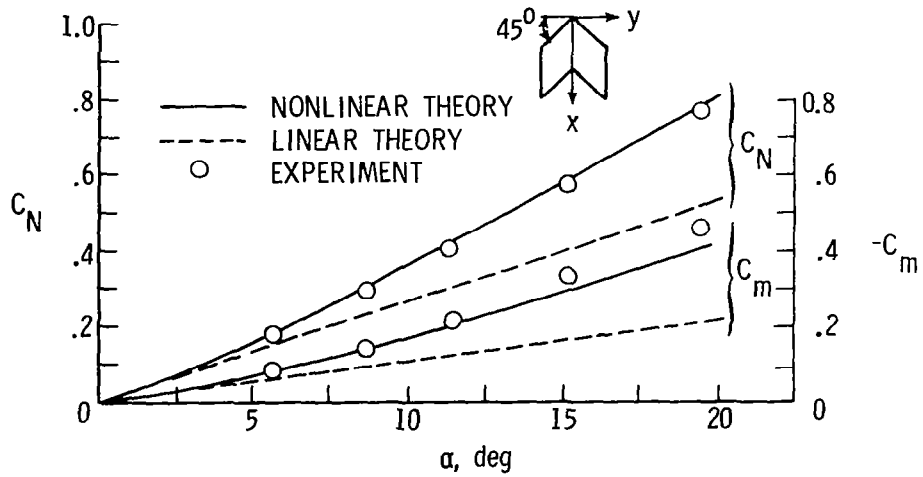

Figure 10.- Normal-force and pitching-moment coefficients for aspect-ratio-1.0 swept wing.

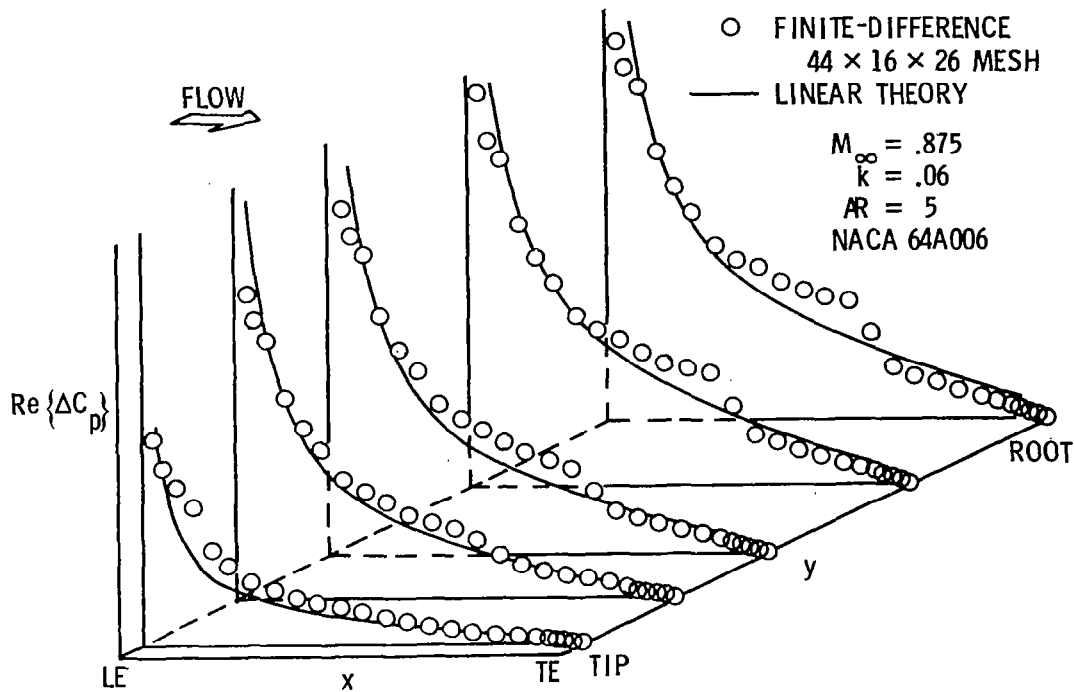

Figure 11.- Real part of pressure distribution on aspect-ratio 5. rectangular wing with NACA 64A006 airfoil oscillating in pitch. $M_\infty = 0.875$, $k = 0.06$.

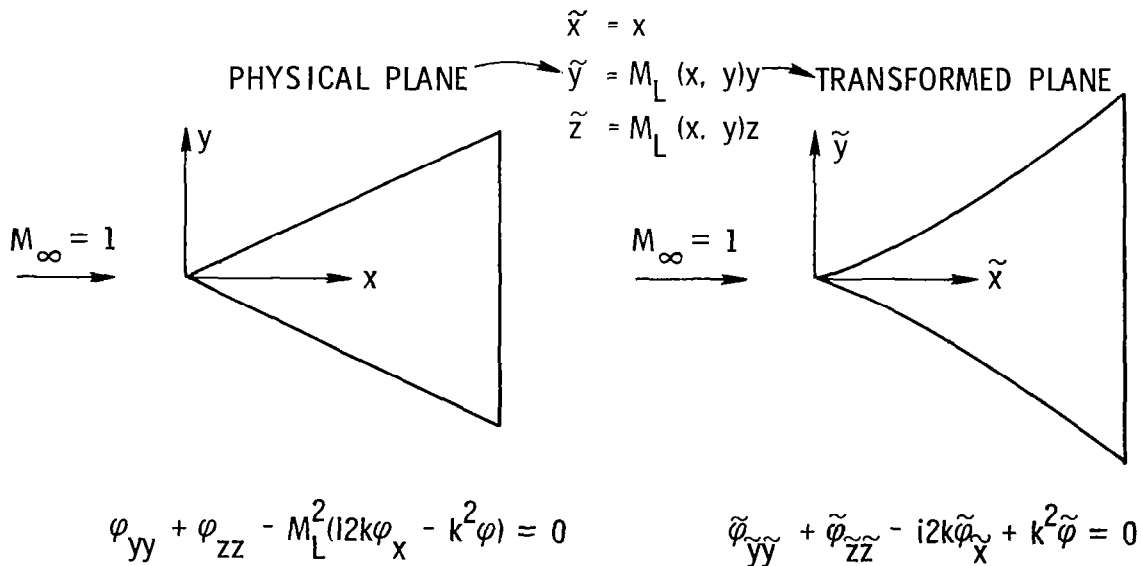

Figure 12.- Coordinate transformation for transonic flow.

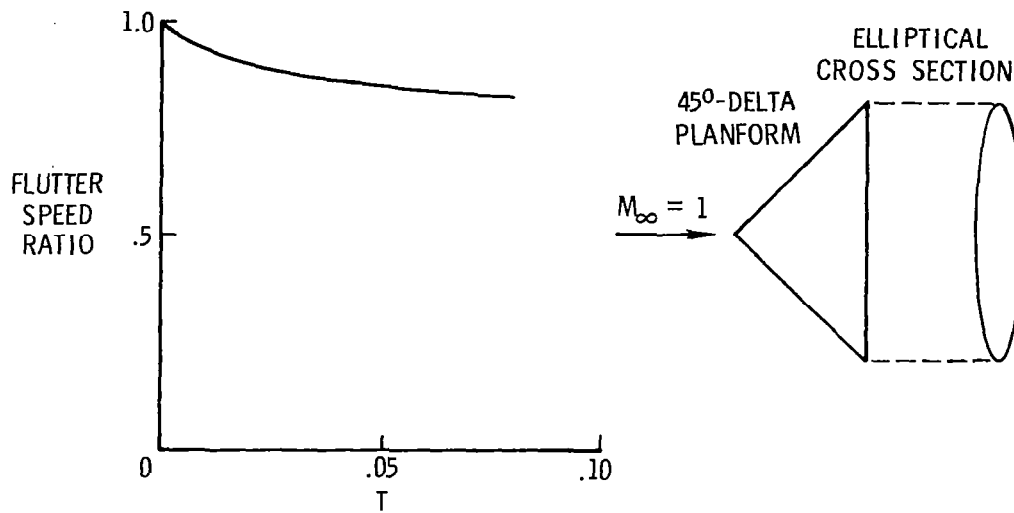

Figure 13.- Effect of thickness on transonic flutter speed.

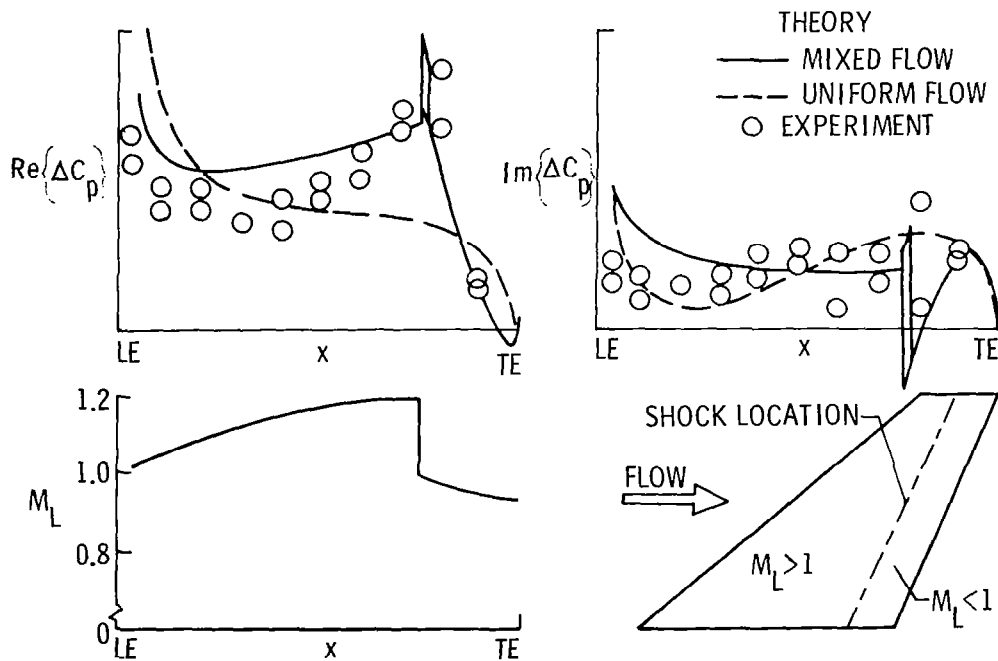

Figure 14.- Pressure distribution at spanwise station 0.556 on wing oscillating in bending. $M_\infty = 0.997$, $k = 0.207$.

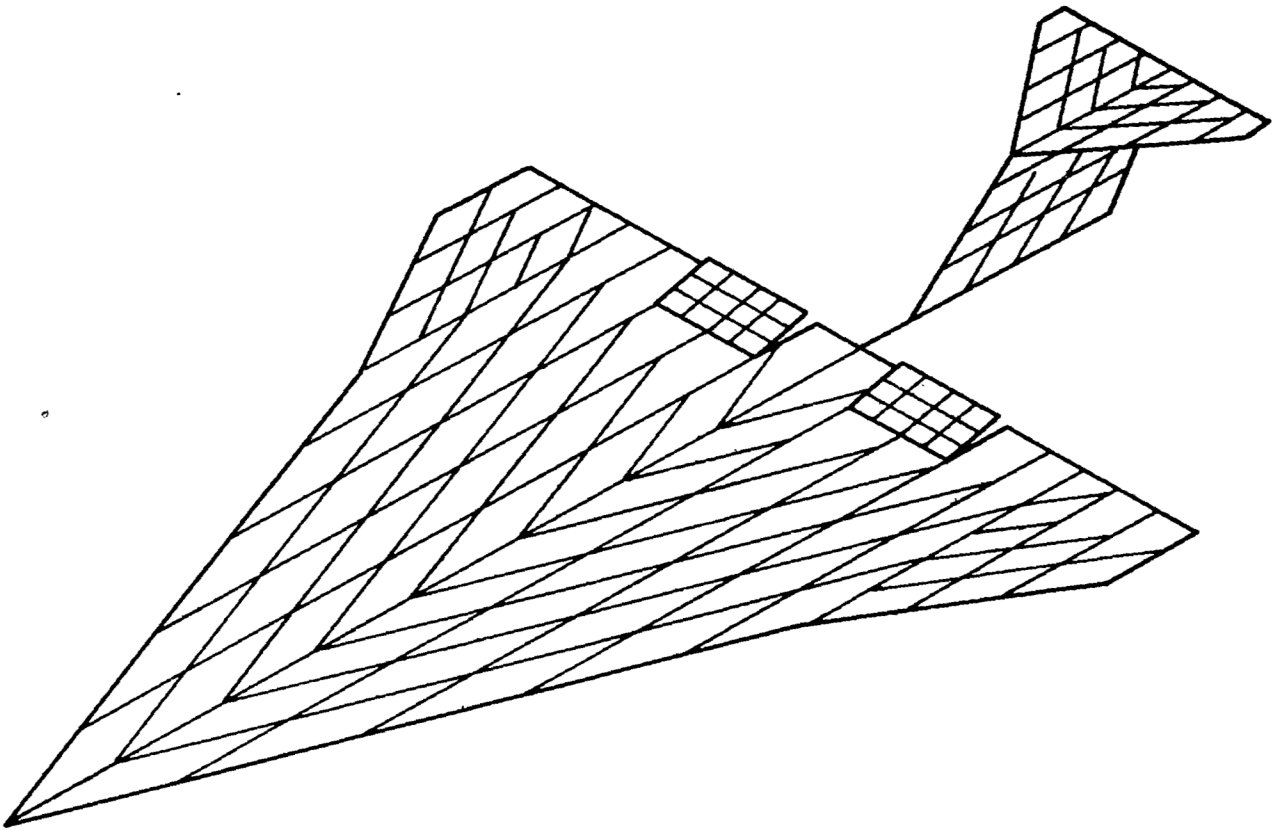

Figure 15.- Geometrical capabilities of oscillatory supersonic lifting-surface panel method.