

N76-28278

ROTARY MECHANISM FOR WIND TUNNEL

STALL/SPIN STUDIES

By Ronald E. Mancini, Dennis S. Matsuhiro,
and Wilbur C. Vallotton

NASA Ames Research Center

ABSTRACT

The critical problem of stall/spin characteristics of high performance aircraft and the need for experimental data in this area are reviewed. A rotary mechanism for obtaining this aerodynamic data in a conventional wind tunnel is presented. The intricacies of the drive systems and the articulation available through such a mechanism are described.

INTRODUCTION

With the advent of higher-performance aircraft, a great deal of research effort has been expended to improve the aircraft's performance capabilities and safety for the crew. One area of increased concern is in the stall/spin characteristics associated with highly swept, low aspect ratio, high angle-of-attack capabilities of current and future aircraft designs. A yearly toll of aircraft and human lives can be directly attributed to loss of attitude control resulting from a stall/spin entered during a high performance maneuver. With new military aircraft being designed for expanded flight envelopes that require even higher angles-of-attack for routine flights, a method of predicting the full-scale spin modes and recovery techniques is needed.

For years researchers have desired a method of obtaining experimental wind tunnel data from which a rigorous analytical approach could be devised for computing the spin characteristics of a given aircraft design. Early attempts at this approach included the building of a free-spin vertical tunnel facility at NASA Langley Research Center. However, these facilities are greatly limited in their Reynolds and Mach number capability. Furthermore, conventional wind tunnel test techniques, where realistic Reynolds and Mach numbers can be achieved, are not sufficient to fully describe the aerodynamic characteristics of an aircraft during a spin.

SYMBOLS

α	model angle-of-attack
β	model angle of side-slip or yaw
γ	offset angle of spin axis from air stream axis
ψ	axis for model positioning
ϕ	axis for model positioning
Ω	spin axis
CW	counterweight axis
HP	horsepower
GPM	gallons per minute
psi	pounds per square inch
rpm	revolutions per minute

ROTARY MECHANISM FOR DATA ACQUISITION

Because of the high Reynolds number capabilities of the NASA Ames wind tunnel facilities, a concerted effort was directed into the design of a rotary balance apparatus for use in a conventional wind tunnel. Such a device would enable aerodynamic data to be obtained under the same local flow conditions as in the full scale spin. The mechanism was to be capable of providing the motions required for generating the force and moment derivatives due to coning as well as damping in both pitch and yaw. Those configurations which are important in understanding the stall/spin problem are illustrated in Figure 1.

BASIC OPERATION

The "Dynamic Stability Rig," seen in Figure 2, supports and rotates an aircraft model inside a transonic wind tunnel test section. The angle of incidence of the model with respect to the air stream can be remotely varied to a maximum of 30° . This is accomplished through rotation about a set of axes (ψ, ϕ) which pass through the center of the model and intersect the spin axis (Ω). These axes are defined in Figure 2. By proper rotation about the ψ and ϕ axes, a particular combination of angle-of-attack (α) and angle of side-slip or yaw (β) may be obtained. The envelope of possible α - β orientations consists of discrete positions within a cone whose apex angle is 60° . This limitation of discrete rather than continuous positions will be discussed later. Using a rear-mounted straight sting model, the maximum α or β is $\pm 30^\circ$.

However, by use of bent stings and top mounted models, this envelope can be expanded to meet the desired range in α of -5° to $+100^\circ$.

Changes in model orientations will be made remotely and prior to spinning the balance in the airstream. The model position is set and the counterweight assembly (see Figure 3) is driven to a position which compensates for the unbalanced static moment about the spin axis (Ω). The entire apparatus is then rotated in the air stream at a rate from 0 to 400 rpm. This high rotation rate, much larger than the full scale spin, is a requirement resulting from one of the modeling parameters in which spin rate is inversely related to model size. For pure coning motion, the spin axis (Ω) of the mechanism is aligned with the tunnel stream axis. To obtain the moments resulting from damping in pitch and yaw, the spin axis (Ω) is slightly offset from the air stream axis by pitching the rotary balance assembly with the tunnel model-support system. This offset is shown as angle γ in Figure 3.

DRIVE ASSEMBLIES

The main drive for the spin rotation is powered by a servo valve controlled hydraulic motor operating a pinion and gear assembly (Figure 2). The motor is capable of producing 64 HP at approximately 1500 psi and 70 GPM.

The overall designs of the drive assemblies for the ψ , ϕ , and counterweight (CW) axes are illustrated in Figures 4 and 6. Figures 5 and 7 show the details of the assemblies. All three drives are similar in design. Rotation is powered by small D.C. electric motors incorporating planetary gear reducers and brakes. A roller chain couples a sprocket mounted on the motor output shaft to the sprocket-and-wave generator assembly of a harmonic drive speed reducer. The output of the harmonic drive is, in turn, mounted to the main shafts of the ψ , ϕ , and CW axes. Because of the large gear reductions involved, rotation rate about all three axes is approximately 30° per minute. All assemblies incorporate solid bearings for space saving considerations.

The CW and ψ drives include a sliding spline-lock mechanism. Centrifugal accelerations at high spin rates acting on particular orientations of the counterweight (CW) or the ψ - ϕ assembly-model combination can result in extremely high moments about the ψ and CW axes. A maximum torque of 70,000 inch-pounds is possible, this being several times the rated static capacity (10,000 inch-pounds) of the harmonic drive units. The remotely operated spline-locks relieve this load on the units by transmitting this torque directly to the main housings (see Figure 5). An internal threaded shaft, rotated by a chain - DC motor drive, operates the spline to engage or disengage the lock of the main shaft to the housing. Indexing for spline engagement is determined by a cam-switch position detector, incorporated in the main harmonic drive wave generator-sprocket assembly. Each revolution of the wave generator operates this cam-switch. The primary axis positioning device is the potentiometer coupled to the rear of the main shaft (Figure 5). When driving to a new position, the rough positioning is performed by use of the potentiometer. The fine adjustment is achieved by activating the cam-switch detector so as to allow alignment of the spline teeth for lock engagement. Spline position overtravel in either engagement or disengagement is prevented by a limit switch assembly, operated by a chain sprocket in the spline-lock drive system.

The ϕ axis drive (see Figure 7 for details) is similar to the ψ and CW drives described above. However, no spline-lock is included in this assembly. The torque load values from aerodynamic and inertia forces about this axis are within the static capacity of the harmonic drive unit. Shaft position again is determined by a potentiometer coupled directly to the main shaft.

Positioning the model in a particular α - β angle combination involves rotation about both the ϕ and ψ axes. The ϕ drive, which includes no spline-lock, is continuous and may assume any angular position. However, due to the discrete allowable positions of the ψ drive, to permit spline-lock engagement, angular motion about this axis is restricted to 2.25° increments or 160 possible lock positions per main-shaft revolution. This results in a limitation that only certain angular combinations of α - β may be obtained. The allowable incremental steps of α or β are dependent on the α - β combination desired.

Electrical power for the drive systems and balance-data acquisition is derived by use of a slip-ring assembly. This is a low-level signal slip-ring unit containing dual brushes and 72 channels. On the rear of the slip-ring unit is mounted an encoder for Ω axis position information and a tachometer for spin rate determination.

CONCLUDING REMARKS

The stall/spin characteristics of modern high performance aircraft and increased capabilities of future aircraft make it highly desirable to obtain experimental data which will enhance the use of analytical techniques for predicting these critical modes. This paper has described a rotary mechanism for wind tunnel studies which should provide the motions necessary for generating this aerodynamic data, specifically, force and moment derivatives, in support of stall/spin analytical programs.

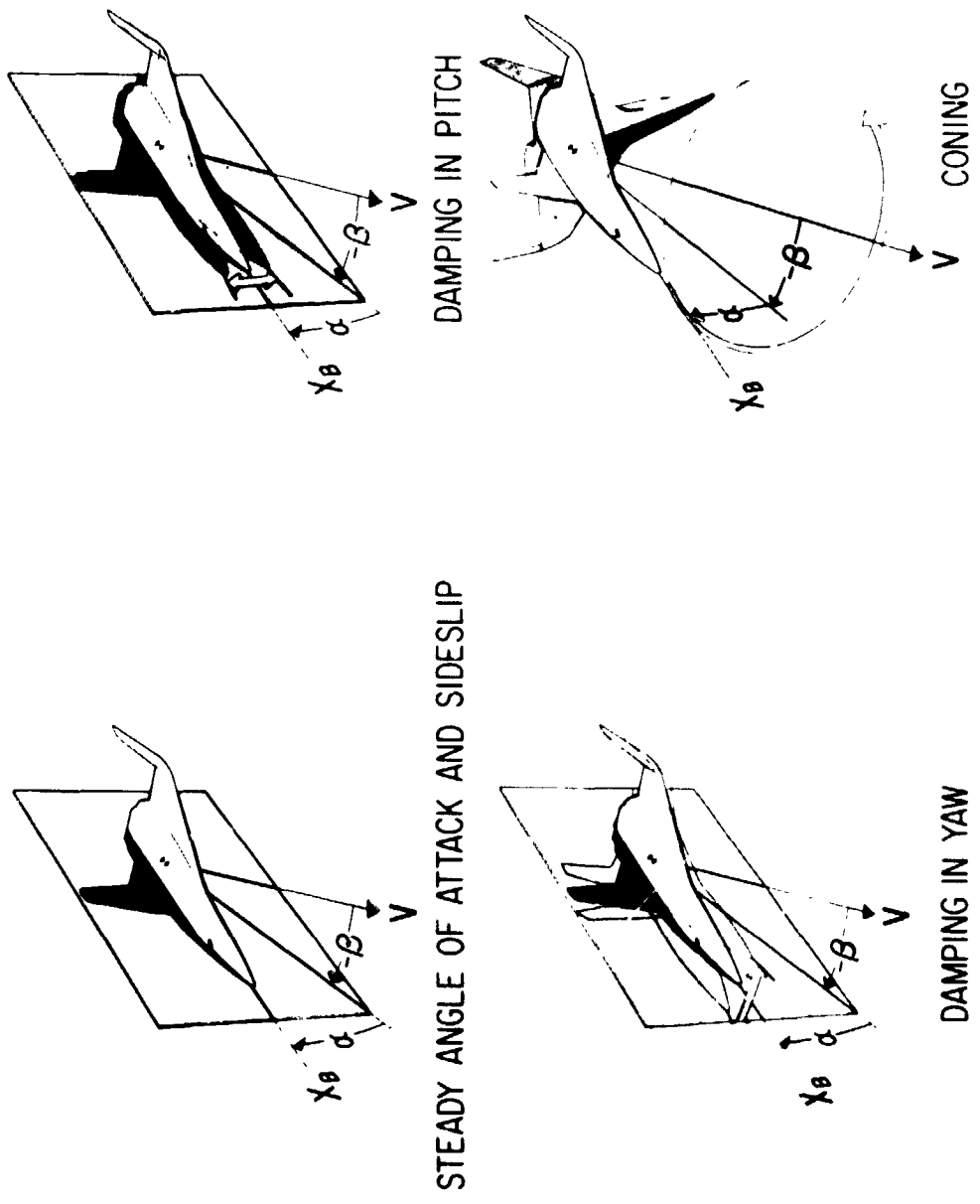

Figure 1. Motions in body axes of interest in stall/spin investigations

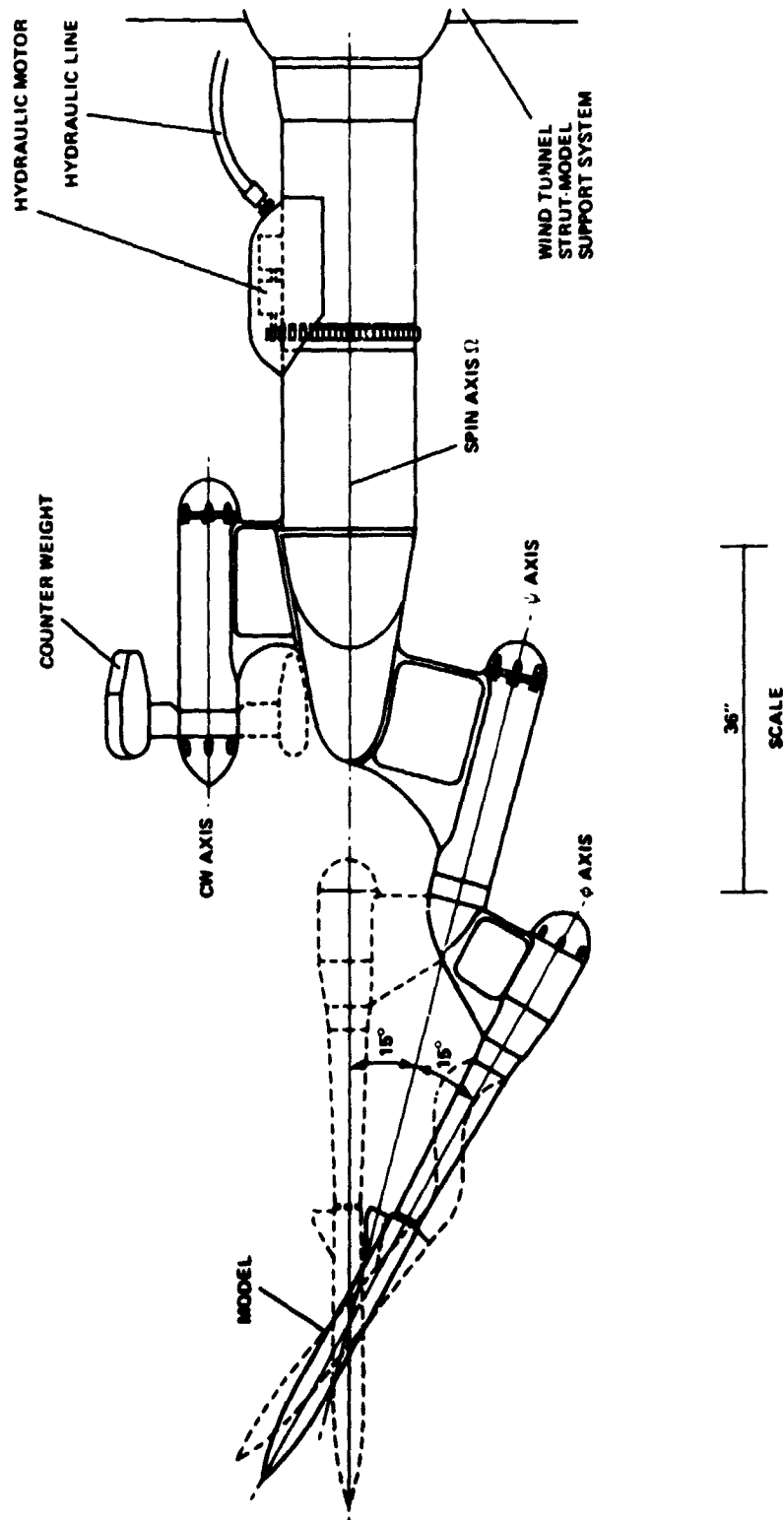

Figure 2. Axis definition and overall view of the "Dynamic Stability Rig"

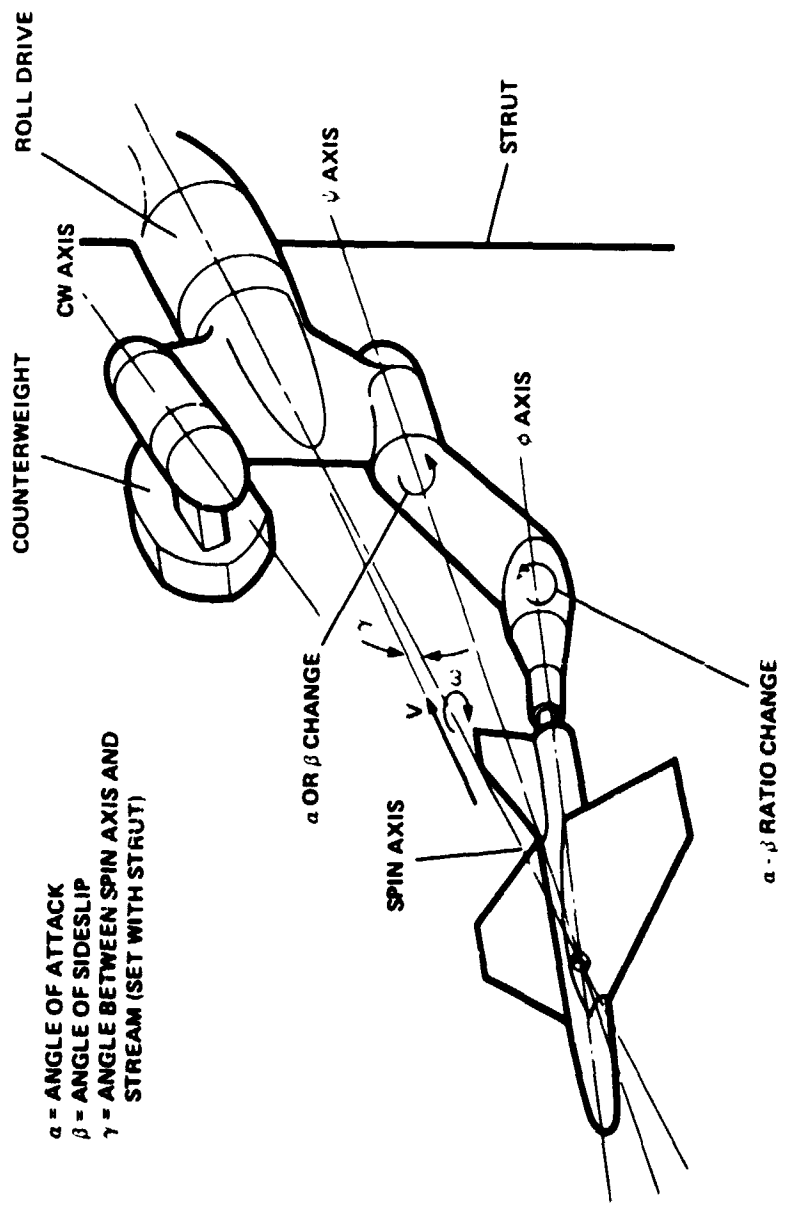

Figure 3. Spin axis is offset from stream axis for damping moment derivatives in pitch and yaw

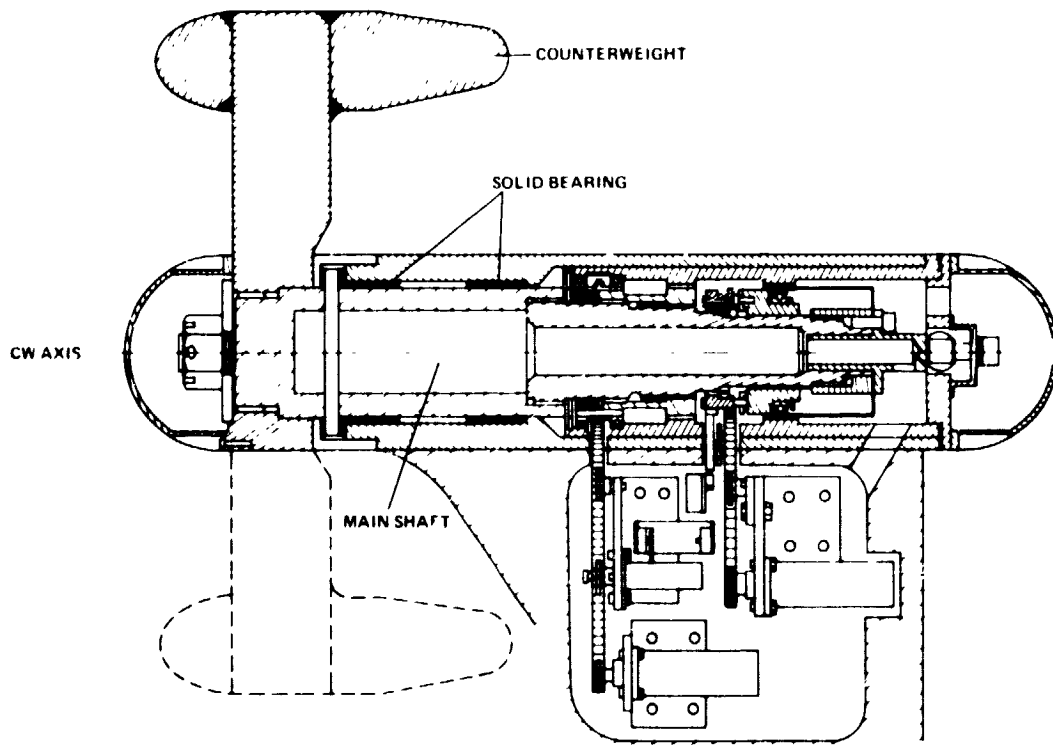

Figure 4. Overall view of CW axis counterweight drive

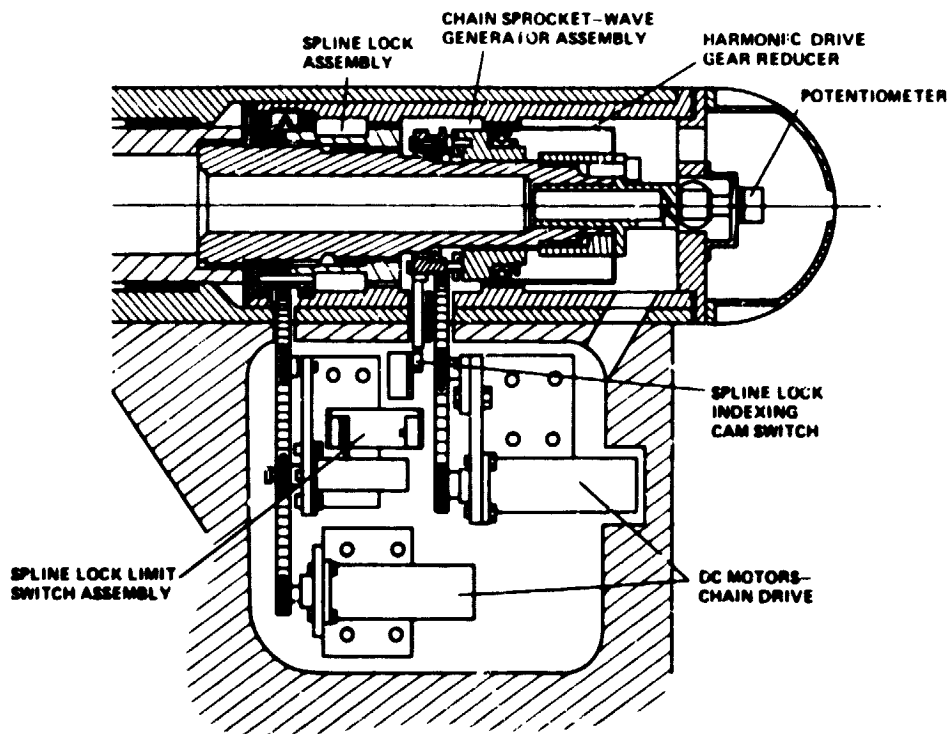

Figure 5. Counterweight or ψ axis drive details

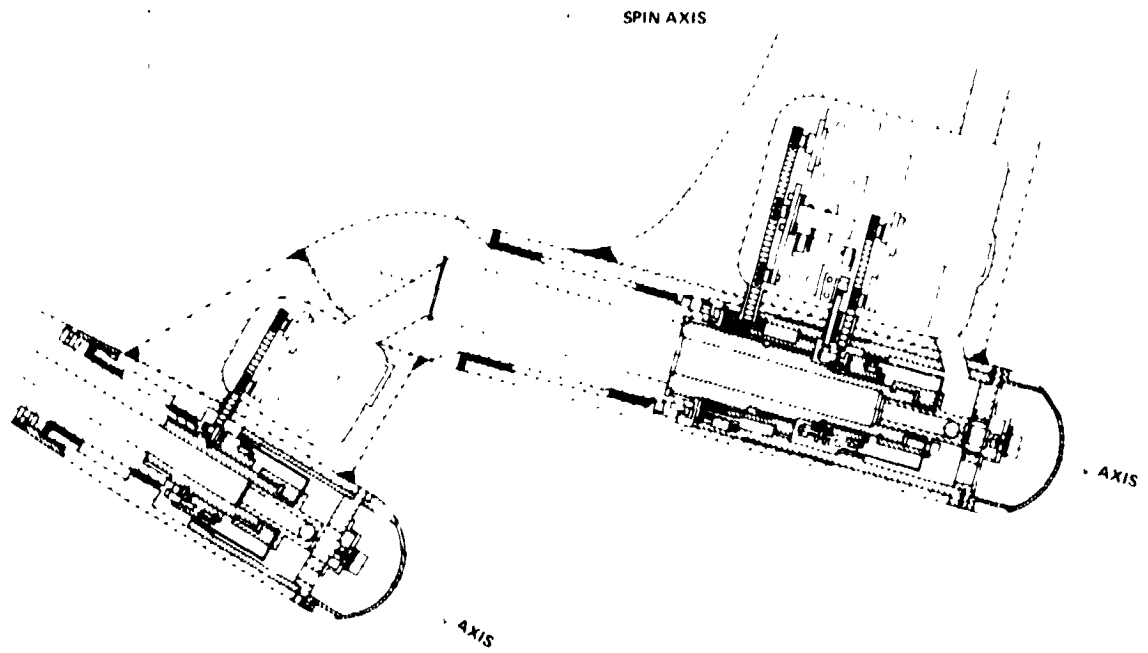

Figure 6. Overall view of ψ and ϕ axis drives

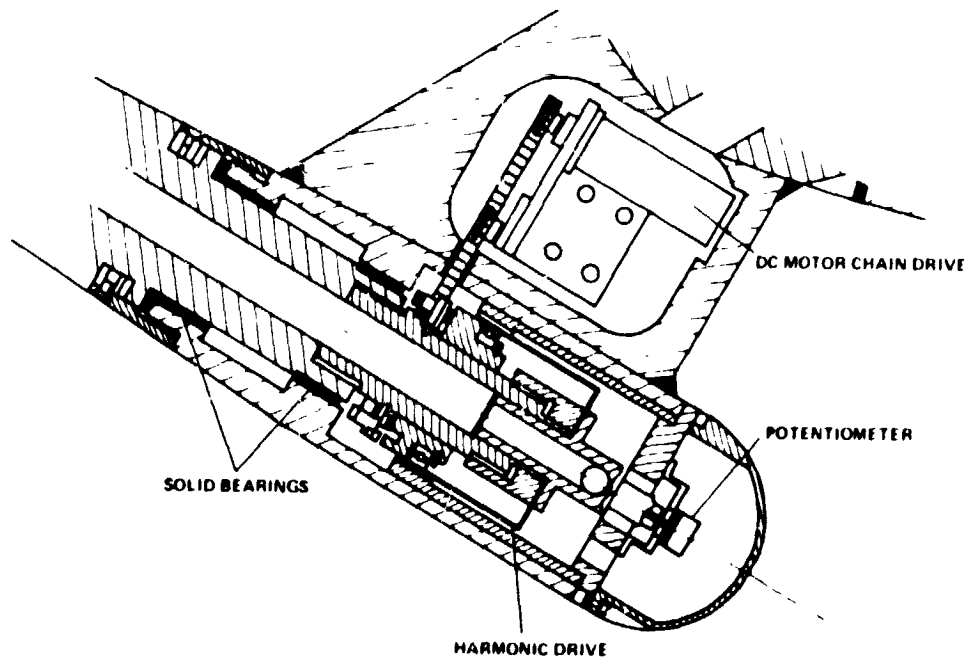

Figure 7. ϕ axis drive details