

# N76-16760

## VEHICLE FOR CIVIL HELICOPTER RIDE QUALITY RESEARCH

William J. Snyder  
NASA Langley Research Center

Ronald G. Schlegel  
Sikorsky Aircraft

### SUMMARY

A research aircraft for investigating the factors involved in civil helicopter operations has been developed for NASA Langley Research Center. The aircraft is a reconfigured 17000 kg (36000 lb) military transport helicopter. The basic aircraft has been reconfigured with advanced acoustic treatment, air-conditioning, and a 16-seat airline cabin.

During the spring of 1975, the aircraft was flight tested to measure interior environment characteristics - noise and vibration - and was flown on 60 subjective flight missions with over 600 different subjects. Data flights established noise levels somewhat higher than expected, with a pure tone at 1400 Hz and vertical vibration levels between 0.07g and 0.17g.

The noise and vibration levels were documented during subjective flight evaluations as being the primary source of discomfort. The aircraft will be utilized to document in detail the impact of various noise and vibration levels on passenger comfort during typical short-haul missions.

### INTRODUCTION

Civil helicopter exploitation has taken a tremendous upsurge in recent years; the onset of tremendous growth in offshore oil operations and the identification of numerous new applications for the helicopter have been contributing factors in a nearly 10 percent per year growth in sales. If this growth is to continue and, particularly, if any inroads are to be made into the short-haul passenger market, then substantial improvement must be made in the vehicles. It was with this idea that the NASA Langley Research Center embarked on a program to upgrade civil helicopter technology. One of the primary areas of concern in the civil helicopter effort is the evaluation of ride quality aspects of short-haul helicopter operations. As part of this effort, a vehicle has been developed for research studies of a broad range of civil helicopter problems including noise, vibration, and other factors affecting ride quality. (See ref. 1.)

The vehicle to be used as a test bed for civil helicopter studies is a reconfigured CH-53A military transport helicopter. The vehicle has been acoustically treated and configured with passenger seats and air-conditioning to simulate an airline interior. While the formal flight studies with the

6

CH-53A have not been initiated, the aircraft has been involved in both a subjective flight evaluation involving several hundred subjects and in a number of interior noise and vibration data flights. The interior noise related results of the latter are presented in reference 2.

The present paper discusses the results of the subjective flight evaluation with the Civil Helicopter Research Aircraft and how the characteristics of the aircraft impact ride quality testing.

## DESCRIPTION OF AIRCRAFT

### Airframe and Systems

The Civil Helicopter Research Aircraft is a reconfigured CH-53A military transport helicopter (fig. 1). The basic characteristics of the aircraft, as reconfigured, are presented in table I. The aircraft was modified from its baseline configuration by the addition of uprated engines which produce nearly 3 MW (4000 shp) each as opposed to about 2.1 MW (2800 shp) each for the original engines. Uprated transmissions to accept the higher power engines were also incorporated. The present control system, rotors, and avionics are unchanged from the basic CH-53A.

### Interior

The interior of the Civil Helicopter Research Aircraft (figs. 2 to 5) consists of four basic areas - the cockpit, a vestibule, a passenger cabin, and a rear cabin compartment.

Cockpit.- The cockpit is a basic CH-53A design with some modifications to accommodate the changes made to the electrical system for the heater, cabin air-conditioning, and lighting systems. There is direct access between the pilot's compartment and the vestibule. A jump seat is provided between, and slightly to the rear, of the pilot and copilot. A night flying curtain separates the cockpit and the vestibule area.

Vestibule.- The vestibule is located to the rear of the cockpit from fuselage station 162 to station 222. The walls are covered with nonacoustically treated decorative panels compatible in color and general design to that of the cabin. Located in the vestibule is a passenger air stair entrance door on the right side of the aircraft, an attendant's seat forward of the door, and a galley and coat locker located opposite the entrance door. The vestibule is shown in figure 2.

Main Cabin.- The main compartment (figs. 3 and 4) is a 4.06-m (13.3-ft) long passenger compartment located to the rear of the vestibule between fuselage stations 222 and 382. The passenger compartment contains eight airline quality double seats (seating for a total of 16 passengers) mounted on tracks with a continuously adjustable seat pitch from 76 to 94 cm

(30 to 37 in.) in 2.54-cm (1-in.) increments. The two individual sections of each double seat are separated by an armrest and have individually adjustable backrests. The minimum aisle width, between seat armrests, is 41 cm (16 in.), and the individual seat sections are approximately 43 cm (16.9 in.) between armrests.

The cabin acoustic treatment is comprised of fiberglass batting, skin damping material and a laminate of polyurethane foam, leaded vinyl, and polyurethane foam. The acoustic treatment is capable of achieving a transmission loss of approximately 40 dB in the preferred speech interference level, PSIL (arithmetic average of the 500-, 1000-, and 2000-Hz center frequency octaves). The cabin interior trim is a molded plastic shell attached to the aircraft structure through rubber isolators.

The floor is raised on either side of the aisle by approximately 6.9 cm (2.7 in.) in order to provide better ground level visibility for the passengers. The seat tracks are mounted on the floor and structurally attached to the aircraft floor frames. The entire floor, including the center aisle, is furnished with carpet padding and high pile carpet.

The forward and rear bulkheads are structurally isolated from the airframe by isolators. The bulkheads are acoustically treated and are covered on the passenger side by a cork covering. In the center of each bulkhead is an acoustically sealed door with a break-open feature and a foot operated floor latch to hold it in the open position.

The cabin has both indirect lighting in the valances located over the seats and direct lighting located down the center of the aisle ceiling. The lighting intensity is controlled in the vestibule and has two intensity positions. No individual lights are provided for the passengers. Emergency exit, no smoking, and fasten seat belt signs are also provided in the cabin.

Cabin equipment consists of fire extinguishers, first aid kits, fire axes, and a telephone intercom system capable of communicating with the crewmembers. There are six speakers spaced throughout the cabin through which can be played 8-track tapes or instructions from a microphone located in the cockpit and accessible to the vestibule.

There are four real windows, two on each side of the aircraft, and twelve simulated windows located in the cabin. The real windows are located at the first and third seat rows. Program economics prevented real windows at each seat location. The window size is approximately 38 cm by 38 cm (15 in. by 15 in.). The real windows are of double pane construction, with the inner pane attached to the acoustic treatment, lightly tinted, and provided with an opaque shade.

The cabin contains air distribution ducts for heated and cooled air. The air inlets are from floor ducts located at the bottom of the sidewalls and downward facing valance ducts. The air return duct is in the upper portion of the valance, between the valance and ceiling, and provides a circuitous distribution flow field down the sidewalls, out from the bottom of

the walls, up the center aisle, and into the return valance ducts. The normal aircraft heating system provides heat for all compartments. The freon air-conditioning system is located in the compartment aft of the passenger compartment. The air-conditioner is designed to provide a total cooling capacity of approximately 17.58 kW (60,000 Btu/hr) while operating in an ambient temperature as high as 44.5<sup>0</sup> C and 50-percent relative humidity.

Individually adjustable gaspers for recirculated air are provided for each passenger.

Aft Compartment.- The compartment aft of the passenger compartment (fig. 5) contains the air-conditioner and duct distribution system as well as the cabin lighting power supply. This compartment is partially treated with military type fiberglass blankets placed on the walls and ceiling. The aft compartment contains three windows, each of which is an emergency exit type. The aft compartment will house flight instrumentation systems and an engineer's station for the NASA flight research program.

## FLIGHT PROGRAM DESCRIPTION

The flight program is actually independent efforts to define the subjective and objective characteristics of the aircraft. The first was a flight effort with limited instrumentation to define the vibration and noise levels within the cabin. The second was an extensive subjective flight evaluation.

### Noise and Vibration Flights

The measurement of noise and vibration levels in the CH-53A was carried out by NASA and Sikorsky engineers. The measurements were accomplished in part during Sikorsky check flights and during scheduled NASA test flights. During the check flights, vibration levels at the blade passage frequency were mapped over the cabin floor area during hover and cruise flight. Likewise, the interior noise levels were mapped during both hover and cruise flight. The NASA test flights included a range of flight conditions - hover, climb, cruise, and descent. During the test flights, fixed microphone and accelerometer locations were utilized. Test flights were flown both before and after the interior was installed. An extensive program to measure environmental conditions, such as noise and vibration, is planned in the near future.

### Passenger Evaluation Flights

The passenger evaluation flight program was considerably more extensive than the noise and vibration flight program. The program encompassed a broad geographic spectrum from Boston to Los Angeles, as shown in figure 6. The typical flight mission (fig. 7) entailed a 304.8- to 457.2-m/min (1000- to

1500-ft/min) ascent to cruise altitude (although conditions occasionally required much higher rates of climb), cruise at altitude with an approximate airspeed of 130 to 140 knots, in-flight shutdown of one engine, and descent and landing.

A total of 60 flights were flown during this evaluation.

## RESULTS AND DISCUSSION

The results of separate data-measuring flights and subjective evaluation flights of the NASA Civil Helicopter Research Aircraft are discussed in the following sections.

### Noise and Vibration Flights

While measurements were taken in a variety of flight conditions, only the cruise data will be discussed.

Figure 8 presents the vertical and lateral vibration levels at the floor for each seat location during a 130-knot cruise; not all locations were measured directly as some were interpolated from the closest available points. The variation in levels is, of course, a function of the mode shapes of the airframe. The levels shown are at a frequency of approximately 18 Hz, or the blade passage frequency of the rotor.

The variation in lateral vibration levels is between  $\pm 0.12g$  and  $\pm 0.17g$ . The range of vertical vibration levels is between  $\pm 0.07g$  to  $\pm 0.17g$ . The corresponding spectra for the vertical and lateral vibrations are shown in figures 9 and 10. The data correspond to vibration levels in the aft cabin, starboard seat locations. The data present the spectrum up to 30 Hz for the 130-knot cruise condition for the vertical and lateral directions. The predominant frequency in both directions is the blade passage frequency of the main rotor, which is 18.3 Hz.

The measured vertical vibration levels (less than 0.1g) in the forward end of the cabin should be acceptable from a passenger acceptance standpoint; however, the lateral levels (greater than 0.1g) are in a more questionable area for passenger comfort and require further study.

A map of the measured interior PSIL (preferred speech interference level) noise levels at each seat location during the 130-knot cruise flight is presented in figure 11. The levels vary from 74 dB PSIL in the forward cabin to 82 dB PSIL in the aft cabin. These levels correspond to levels in the older jet transport aircraft (727, etc.) in the mid- to aft cabin; however, these levels do not adequately reflect a pure tone at 1400 Hz caused by the first stage planetary gear clash in the main transmission. This gear clash frequency, while not in the hearing damage range, is annoying because of its

pure tone nature at a level above other noise in the cabin. Further discussion of the interior noise can be found in reference 2.

### Subjective Flight Evaluation

The following section presents a discussion summarizing over 60 flights and over 600 subjective reactions to the ride qualities of the aircraft.

During each subjective flight of 15- to 20-minute duration, the subject was requested to complete a questionnaire (table II). A summary of the occupational backgrounds of the test subjects is presented in tables III and IV. The subject sample was generally representative of the helicopter industry and related fields including government (foreign and domestic). The flight experience background of the subjects is as follows: 22 percent had never flown in a helicopter; 29 percent had flown less than 10 times; and 49 percent had flown over 10 times. The average rating on a scale from 1 to 9, where 1 represents very comfortable, was 2.5.

Table V presents a summary of the five top environmental conditions that caused discomfort to the passengers/subjects. High frequency noise was the most frequent problem area, causing discomfort to 64 percent of the subjects. Vibration was the next greatest complaint, with 46 percent experiencing discomfort. Cabin pressure, low frequency noise, and workspace complete the list. It should be noted that the cabin pressure problem was related to rapid climbs and descents which did not occur on every flight. Had the rapid climbs and descents occurred on every flight, the rapid changes in cabin pressure may have been a more widespread problem. Table VI presents the general results of passive problems with the aircraft; that is, problems with the fixed location or fixed facilities within the cabin. The primary complaints were a function of the window locations and size.

In general, according to the subject survey data, the subjects felt the aircraft was competitive with fixed-wing aircraft in overall comfort and were willing and, in the majority of cases, eager to take another flight. The negative aspects most frequently brought out were the high frequency noise, vibration, and the window locations.

Looking now in somewhat more detail at the data, table VII presents the overall rating matrix of each seat location. The number of ratings at each comfort level is shown against seat location. It can be seen that the two-seat rows with windows had lower ratings than the rows without windows. Likewise, the ratings in the rear of the cabin with the higher noise levels and vibration levels are the highest ratings. There is no general trend indicated when either the noise or the vibration levels are compared with the average rating at each seat location; however, there is (as shown in fig. 12) a correlation between the average rating and the noise level for the two rows of seats without windows. Comparing the two rows of seats with windows does not show the effect of the increased noise level. It appears that the lack of windows increases the sensitivity to noise annoyance.

One additional problem area that arose during the testing that may be significant is blade flicker (stroboscopic effect of sunlight through rotor). The problem was not widespread but deserves further attention.

## GENERAL DISCUSSION

The Civil Helicopter Research Aircraft, as a tool for ride quality testing, presents a challenging opportunity to investigate a wide variety of conditions. The environment is generally acceptable for short duration missions, although certain aspects have been shown to be marginally acceptable, including the vibration levels and interior high frequency noise levels.

As an instrument for ride quality testing, it would be desirable to have certain conditions where the vehicle would be totally acceptable to the average subject; however, this does not appear possible with this aircraft due to the main transmission noise level being objectionable in most all flight conditions. The vibration level can be varied considerably and can probably be made acceptable at certain airspeeds, although a complete documentation through all conditions and configurations (cg, gross weight, airspeed) has not been conducted to date. An additional area that still requires further definition is the impact of much lower vibration levels at the lower harmonics of rotational speed of the main rotor. From the data, it is obvious that the blade passage frequency of 18 Hz (6 times the rotor speed) dominates all other frequencies by at least an order of magnitude; however, the lower harmonics (1 and 2 times the rotor speed) may be unacceptable because they are nearer the comfort zone frequencies of the body.

The most important area that can be investigated with this aircraft is that of the long-range effects of vibration and noise levels on flights of up to two hours. For flights of this nature that could simulate short-haul missions, the aircraft can carry up to 16 subjects. The aircraft has sufficient variability in vibration level to investigate the reaction of subjects to prolonged exposure to several levels of vibration.

Variables such as seating direction, seat pitch, attitude, and airspeed will all be investigated with the vehicle. Terminal-area maneuvers, blade flicker, and breadboard treatments to reduce reverberation in the cabin will also be investigated.

## CONCLUSIONS

A modified version of the CH-53A military transport helicopter has been flown in an extensive program to obtain in-flight subjective evaluation of the general characteristics of large helicopter airliners. The vehicle has also been flight tested by NASA and Sikorsky engineers to obtain preliminary noise and vibration data on the aircraft. This paper has presented a summary

of the results of these two flight test efforts and the following conclusions are drawn.

The most serious drawback of the Civil Helicopter Research Aircraft as a ride quality research vehicle is the high frequency noise transmitted from the main transmission. This problem reduces the probability of establishing a totally acceptable baseline condition. The capability to systematically increase the cabin noise levels does exist, however.

Vibration at rotor blade passage frequency and the lower harmonics of rotor speed is somewhat higher than desirable, but it is felt that these levels can be brought to acceptable levels by proper choice of flight conditions and configurations.

Blade flicker, window size and location, and seat pitch have been identified as items requiring further investigation.

The Civil Helicopter Research Aircraft presents an opportunity to investigate not only the many aspects of large helicopter environments that affect passenger comfort, but also to investigate techniques for noise reduction and vibration reduction and to establish the effects of prolonged flight and the exposure to maneuvers that may be required in future terminal-area operations.

#### REFERENCES

1. Daniell, R. F.; and Warren, R. E.: Short Haul Transportation - The Helicopter's Time is Now. [Preprint] 750598, Soc. Automot. Eng., May 1975.
2. Howlett, James T.; and Clevenson, Sherman A.: A Study of Helicopter Interior Noise Reduction. NASA TM X-72655, 1975.



TABLE I.- CIVIL HELICOPTER RESEARCH AIRCRAFT CHARACTERISTICS

	<u>SI</u>	<u>U.S. Customary</u>
Mission gross weight . . . . .	16586 kg	36573 lb
Empty weight . . . . .	11575 kg	25525 lb
Alternate gross weight . . . . .	19047 kg	42000 lb
High speed cruise . . . . .	304 km/hr	164 knots
Normal speed cruise . . . . .	278 km/hr	150 knots
Range . . . . .	448 km	242 n. mi.
Length . . . . .	17.2 m	56.46 ft
Height . . . . .	5.07 m	16.63 ft
Width (blades folded) . . . . .	4.72 m	15.50 ft
Main rotor diameter . . . . .	21.9 m	72 ft

TABLE II.- QUESTIONS FOR FLIGHT EVALUATION SURVEY

1. What is your primary occupation or professional title?
2. What organization, industry, or special service do you represent?
3. Please specify your seat location.
4. How many times have you traveled by helicopter?  

This is my first time	1-5	6-10	More than 10
-----------------------	-----	------	--------------
5. Please indicate your overall reaction to this demonstration flight:  

1	2	3	4	5	6	7	8	9	
Very Comfortable									Very Uncomfortable
6. Check the box which indicates your feelings about each of the following items on this demonstration flight:  

	Some	
	Comfortable	Discomfort
		Uncomfortable

  - Pressure (on ears)
  - High Frequency Noise
  - Low Frequency Noise
  - Odors
  - Temperature
  - Ventilation
  - Workspace
  - General Vibration
  - Sudden Jolts
  - Acceleration
  - Up and Down Motion  
(bouncing)
  - Backward and Forward Motion
  - Sudden Descents
  - Turning

TABLE II.- Concluded.

7. Include your reaction to each of the following statements:

	Yes	No	Comment
The seat has enough leg room			
The window size is satisfactory			
The firmness of the seat is satisfactory			
The window height is satisfactory			
The seat is wide enough			
The window location is satisfactory			
The shape of the seat is satisfactory			
The window location had very little effect on my comfort			
The seat can be adjusted to satisfaction			

8. How does this demonstration flight compare to your experience in a fixed-wing aircraft?

Much better      Better      Equal      Worse      Much Worse

9. After experiencing this demonstration flight, I would: (check only one)

- Be eager to take another flight
- Take another flight without any hesitation
- Take another flight, but with some hesitation
- Prefer not to take another flight
- Not take another flight

10. Comments.

TABLE III.- OCCUPATION OF FLIGHT EVALUATION SUBJECT SAMPLE

Management	150
Technical	68
Politics	47
Business	23
Pilot	66
Aircraft Ground Support	12
Housewife	7
Miscellaneous	227
No Answer	<u>5</u>
	605

TABLE IV.- EMPLOYING ORGANIZATIONS OF FLIGHT EVALUATION SUBJECT SAMPLE

Oil Industry	38
Helicopter Airline	67
FAA	47
Army	2
Navy	7
Air Force	1
NASA	64
Foreign Military	27
Other Government (Local, State, Federal)	105
Transportation Industry	42
Helicopter Manufacturer	53
Miscellaneous	141
No Answer	<u>11</u>
	605

TABLE V.- PRIMARY ENVIRONMENTAL FACTORS\* CAUSING DISCOMFORT TO SUBJECTS

	<u>Comfortable</u>	<u>Some Discomfort</u>	<u>Uncomfortable</u>
High Frequency Noise	36%	49%	15%
General Vibration	54%	42%	4%
Cabin Pressure (On Ears)	64%	31%	4%
Low Frequency Noise	78%	21%	1%
Workspace	84%	15%	1%

\* Eleven other factors were noted as causing some discomfort by 11% or less of the subjects.

TABLE VI.- PRIMARY CONFIGURATION FACTORS\* THAT ELICITED NEGATIVE COMMENTS

	<u>Yes</u>	<u>No</u>
Window location had little effect on comfort	72%	28%
Window size is satisfactory	77%	23%
Seat is wide enough	77%	23%
Window location is satisfactory	84%	16%
Window height is satisfactory	86%	14%

\* Other factors elicited 6% and less negative comments.

TABLE VII.- SEAT LOCATION VERSUS OVERALL RATING

Seat	Comfortable					Uncomfortable				Average	Totals	
	1	2	3	4	5	6	7	8	9			
Window Row	1	16	10	10	3	3	2	2	0	0	2.59	46
	2	15	8	8	2	1	1	0	1	0	2.28	36
	3	14	12	12	3	2	0	0	0	0	2.23	43
	4	15	9	15	4	2	1	1	0	0	2.49	47
Window Row	5	10	3	8	8	3	0	0	0	0	2.72	32
	6	10	5	6	2	0	3	1	0	0	2.63	27
	7	8	1	10	2	1	1	1	0	0	2.75	24
	8	9	4	10	5	0	0	0	0	0	2.39	28
	9	15	14	12	3	4	0	0	0	0	2.31	48
	10	18	7	12	1	0	2	0	0	0	2.10	40
	11	17	7	9	6	1	0	0	0	0	2.17	40
	12	14	11	13	7	2	0	1	0	0	2.50	48
Window Row	13	4	5	4	6	0	0	1	0	0	2.85	20
	14	6	5	6	2	3	2	0	0	0	2.87	24
	15	4	2	7	0	2	1	0	0	0	2.81	16
	16	3	2	6	2	3	0	3	0	0	3.63	19
Grand Average										2.50		

Note: Averages were obtained by weighing scores by the number of their overall reaction. A rating of 1 received a weight of 1, a rating of 2 received a weight of 2, etc.



Figure 1.- Civil Helicopter Research Aircraft.



Figure 2.- Civil Helicopter Research Aircraft. Vestibule.



Figure 3.- Civil Helicopter Research Aircraft.  
Main cabin (looking forward).



Figure 4.- Civil Helicopter Research Aircraft.  
Main cabin (looking aft).



REPRODUCIBILITY OF THE ORIGINAL PAGE IS POOR

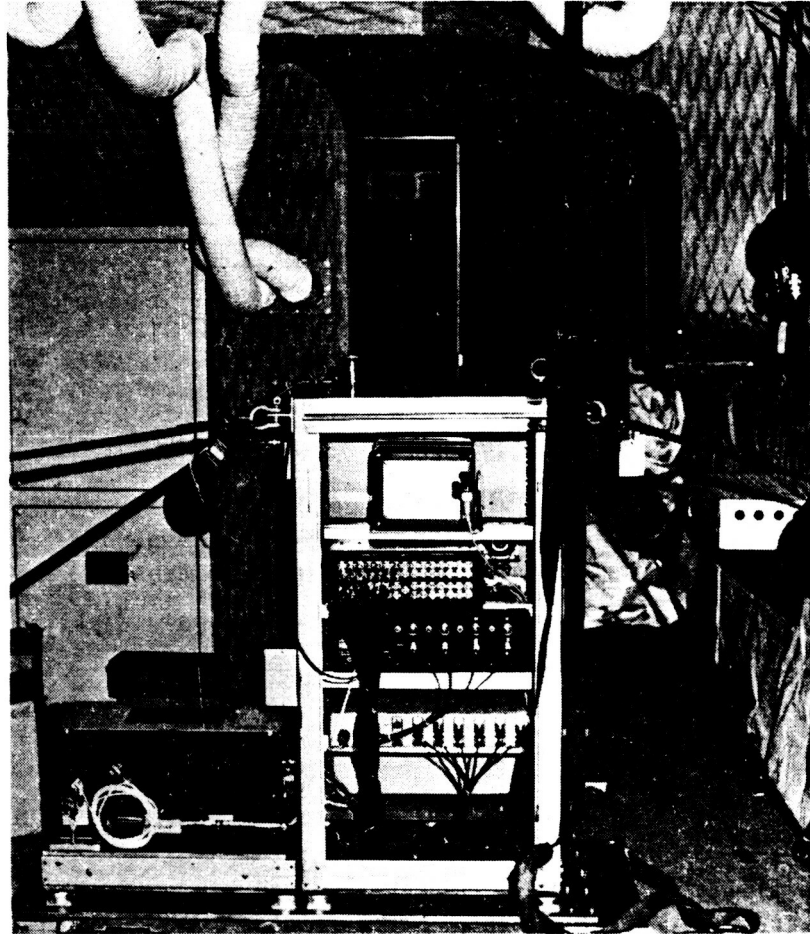

Figure 5.- Civil Helicopter Research Aircraft. Aft compartment (looking forward).

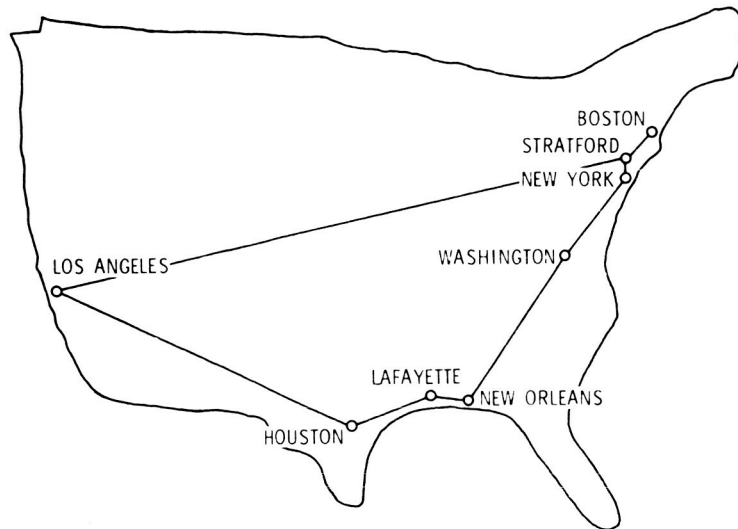

Figure 6.- Locations for Civil Helicopter Research Aircraft subjective flight evaluation.

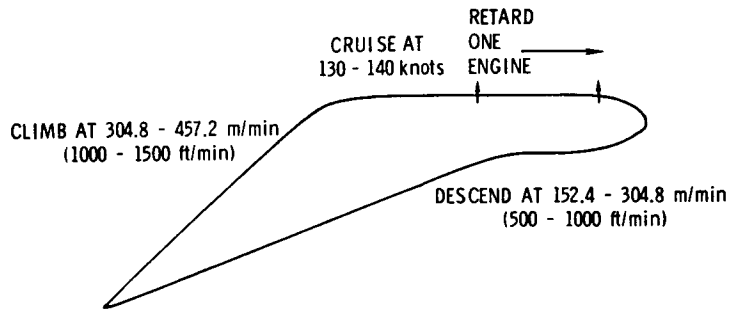

Figure 7.- Typical flight evaluation mission.

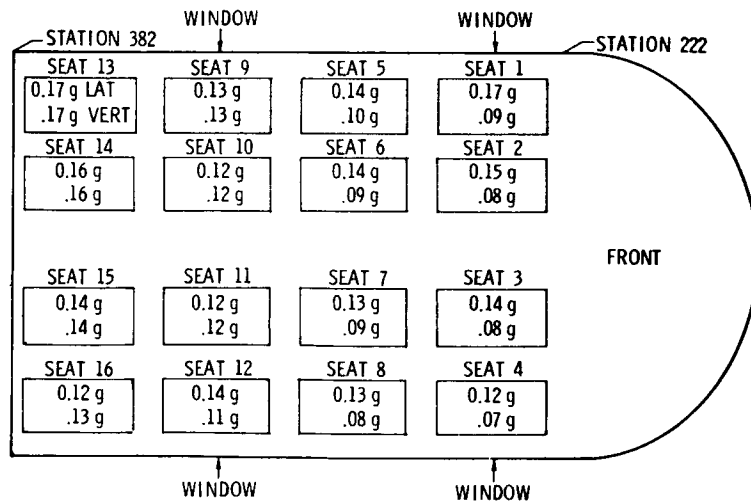

Figure 8.- Aircraft vibration environment versus seat locations.

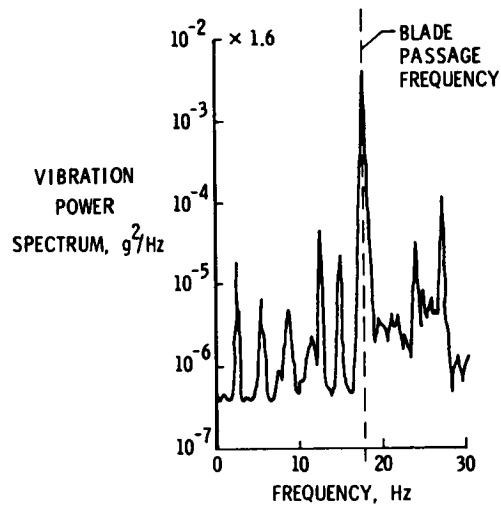

Figure 9.- Vertical vibration power spectrum.

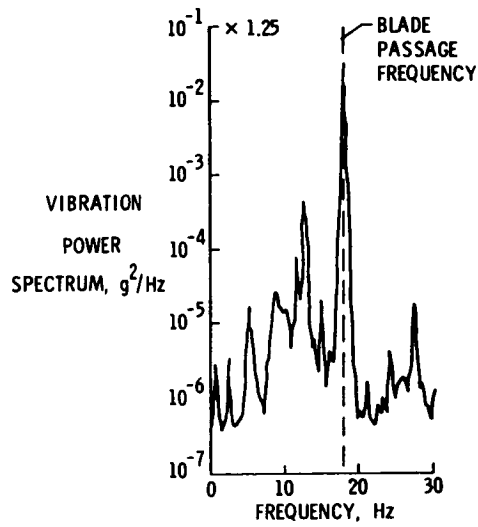

Figure 10.- Lateral vibration power spectrum.

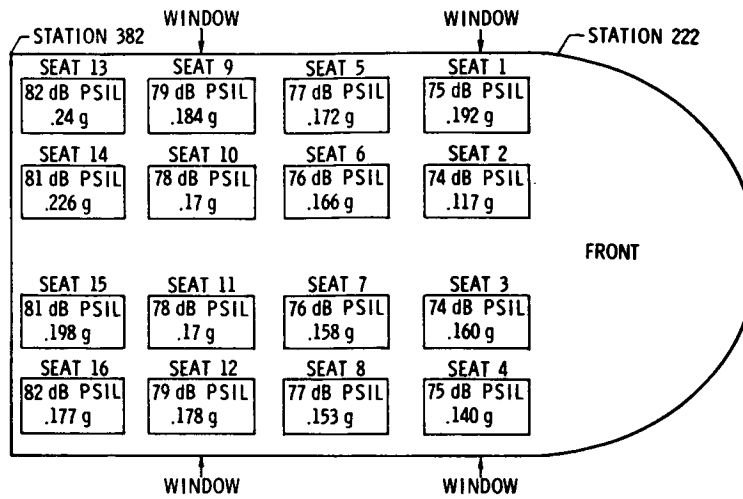

Figure 11.- Aircraft PSIL noise environment versus seat locations.

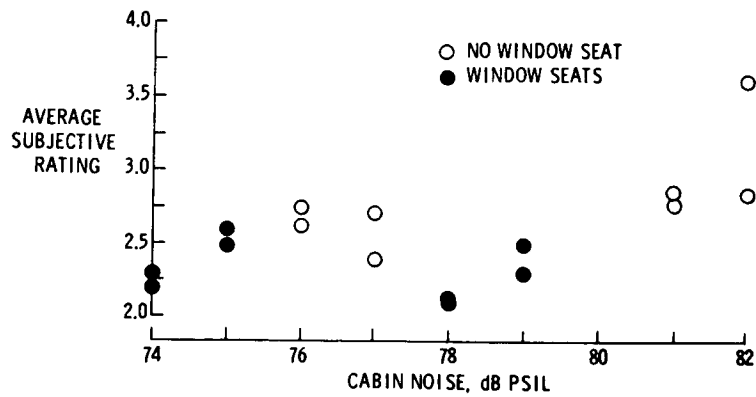

Figure 12.- Average subjective rating versus PSIL noise levels.