

N76-15050

THE AIRFLOAT HL PROJECT

Edwin Mowforth *

ABSTRACT: This paper describes a design study for a large low-cost rigid airship intended primarily for the movement of large indivisible loads between unprepared sites. A survey of the ship and its overall performance is followed by accounts of the operational procedures for the above function and for an alternative application to unit module transfer between fixed terminals. A final section indicates the estimated costs of construction and operation.

Objectives

The Airfloat HL (Heavy Lift) project was initiated late in 1970 as a design study for an airship to carry large indivisible loads over moderate distances - typically, 400 tonne over 2 000 km - between unprepared and possibly congested industrial sites. The associated requirement of minimum cost has dictated a 'low technology' design policy making the greatest practicable use of currently accessible materials, installations, techniques and experience in order to bypass, wherever possible, expensive involvement in research and development programmes. The outcome is a vehicle lacking sophistication and falling somewhat short of optimum technical efficiency, but offering the facilities of rapid manufacture and of immediate commercial effectiveness even if only one ship is built.

* Design Director, Airfloat Transport Limited, and Lecturer in Mechanical Engineering, University of Surrey.

General Description

Hull - The hull is seen from Fig 1 to be of conventional form, 400 m long and 85 m in diameter; it comprises a light alloy framework covered by a textile skin and divided internally by radially-braced transverse frames into 27 cells, each containing a reinforced Mylar gasbag to give a total helium capacity of 1 342 000 m³.

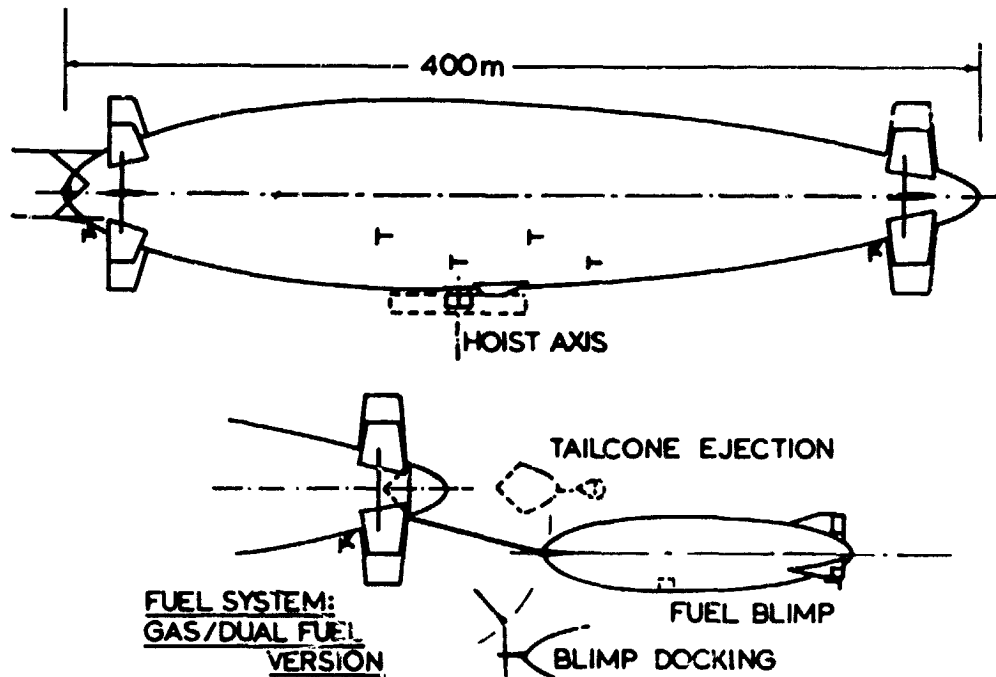

Fig.1. GENERAL ARRANGEMENT OF AIRFLOAT HL AIRSHIP

Propulsion - The ship carries 10 Rolls-Royce Marine Proteus dual fuel gas turbines, each driving a 6.4 m diameter Hawker Siddeley propeller. 2 units are mounted at nose and tail and can be vectored for lateral thrust, while 6 of the 8 disposed along the lower flanks can vector the propellers for vertical thrust. The ship normally cruises at 145 km/h using 4 engines when alone or 5 when towing a fuel blimp.

Control - To achieve the necessary position control in hovering flight there are 8 radially disposed fully-floating fins at either end of the hull, hydraulically powered through independent pump and motor sets driven electrically by duplicated gas turbine generator sets in the nose. Hovering and normal cruise control are automatic, gusting being sensed by the forward probes and compensated by control operation under the direction of a master control unit.

Fuel - The ship may operate on aviation kerosine, on natural gas or on dual fuel, a combination of both.

Kerosine operation uses 2 fixed 20-tonne tanks, topped up in flight from 10-tonne transfer tanks picked up and carried with the payload or ballast. The cruising weight loss of 4 tonne/h is met by routine journeys over free water surfaces from which water may be raised at intervals of up to 1 000 km through suspended pumps and hoses with the ship trimmed in hovering flight by vertical thrust. Between stops the discrepancy is met by dynamic lift, and the interval may occasionally be extended by the use of a rain water collection system.

On natural gas operation the HL airship tows a blimp, 135 m long, which carries 59 000 m³ of fuel gas; this offers an effective stage length of about 1 200 km. The blimp has its own propulsion unit and control system and can fly independently under radio control, so that refuelling may be effected by detaching the empty blimp and docking a full one with the HL ship flying at 60 km/h. While the blimp is detached the HL ship runs on a bridging supply of 5 000 m³ of fuel gas housed in a tailcone which may be ejected in case of fire; a further reserve of kerosine extends the operating period in an emergency.

Natural gas from European sources is lighter than air, so that the blimp becomes heavier as fuel is consumed. In the above system the blimp carries water ballast which is progressively discharged to balance the lift loss; in the alternative dual fuel system this water is replaced by kerosine which is pumped forward and consumed at the necessary rate to maintain trim. The Proteus engines of the HL ship may all run on either gas or kerosine, and the necessary dual fuel ratio is maintained by alternating between different combinations of gas and oil burning units. The effective stage length using the 135 m blimp is then 2 000 km.

Loading System - Loads are picked up in hovering flight by attachment to a frame suspended from a swivelling hoist mounted in the hull. The hoist is driven electrically, being powered by two gas turbine generator sets; it can be rotated to align the frame with the load axis regardless of wind direction, and has a compensation system for pitch and roll of the hull during load transfer. The use of the system in Open Site and in Module Operation will be described in a later section.

Accommodation - The control deck and crew accommodation are in two offset nacelles adjacent to the hoist. A cruising crew of 3 is envisaged, with a nominal load exchange handling crew of 4. In 24-hour operation on extended circuits 3 full crews and 3 cabin staff may be carried, totalling 24. A transfer lift between the nacelles permits the exchange of personnel and small stores with the ground while hovering.

Performance

Under ISA conditions and assuming 5% air contamination of the lifting helium, the gross disposable lift values corresponding to pressure heights of 500, 1 000 and 1 500 m become respectively 520, 460 and 400 tonne for the oil-burning version, reduced by 8 tonne for the gas and dual fuel versions with tailcone gas storage. With a 10-tonne reserve of kerosine and 20% excess range allowance, the range-payload relationships are indicated in Fig 2 for cruise at 145 km/h close to the pressure height, using 4 engines on the kerosine version and 5 on the blimp-towing types.

In all cases the payload corresponding to a given pressure height will fall by about 10 tonne for every 3°K rise in atmospheric temperature, and vice versa.

The nose engine is not suitable for axial propulsion, but flight is possible on any symmetrical combination of the remaining 9 units; on 9 engines at economical cruise (3 000 hp) the airspeed in ISA conditions becomes 205 km/h for the kerosine ship and 190

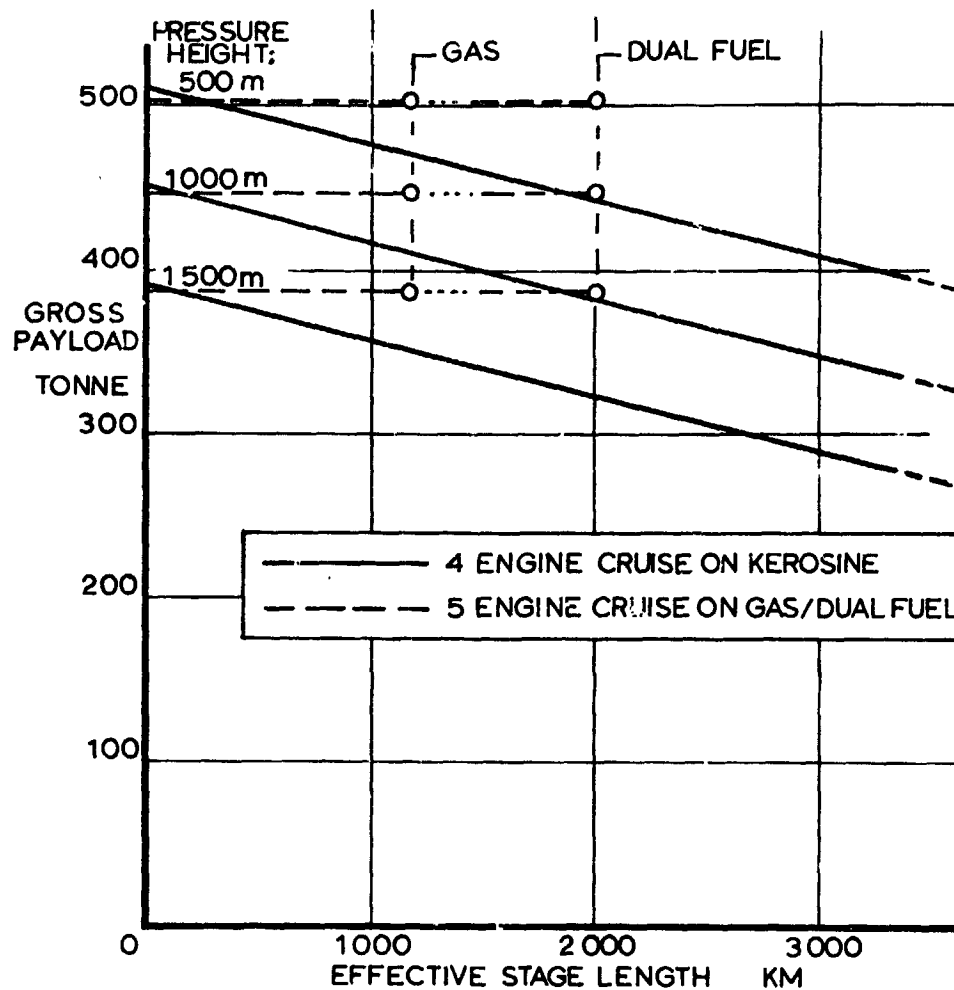

Fig. 2. PERFORMANCE OF AIRFLOAT HL AIRSHIP (ISA)

when towing a blimp; the corresponding 'idling' speeds on one engine only are 75 and 70 km/h. All quoted speeds refer to axial flight and may fall by 2 or 3 km/h when the hull axis is pitched for dynamic lift.

Open Site Operation

For the movement of large indivisible loads between industrial sites the hoist frame is coupled as in Fig 3 to a load frame which has ballast frames suspended from electric winches at its ends. Latches on the load frame bottom booms correspond with pickups on simple sub-frames which have been built onto the load prior to its proposed transportation date.

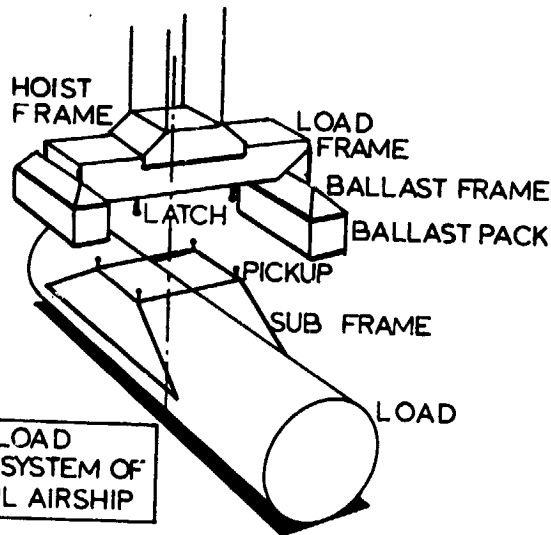
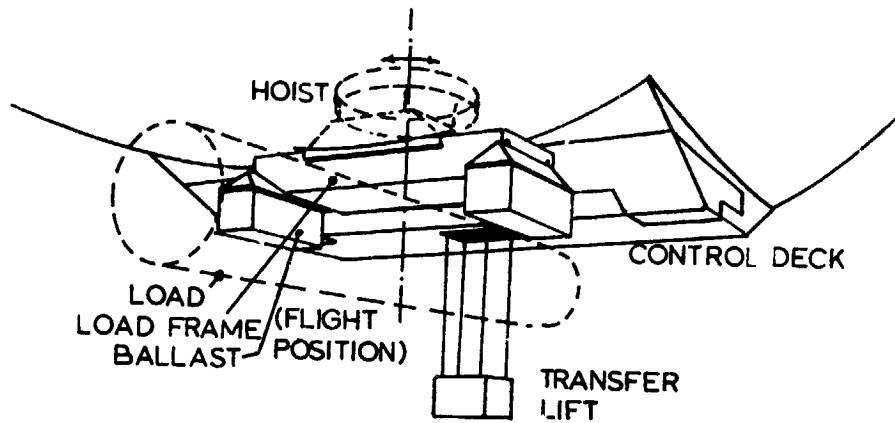
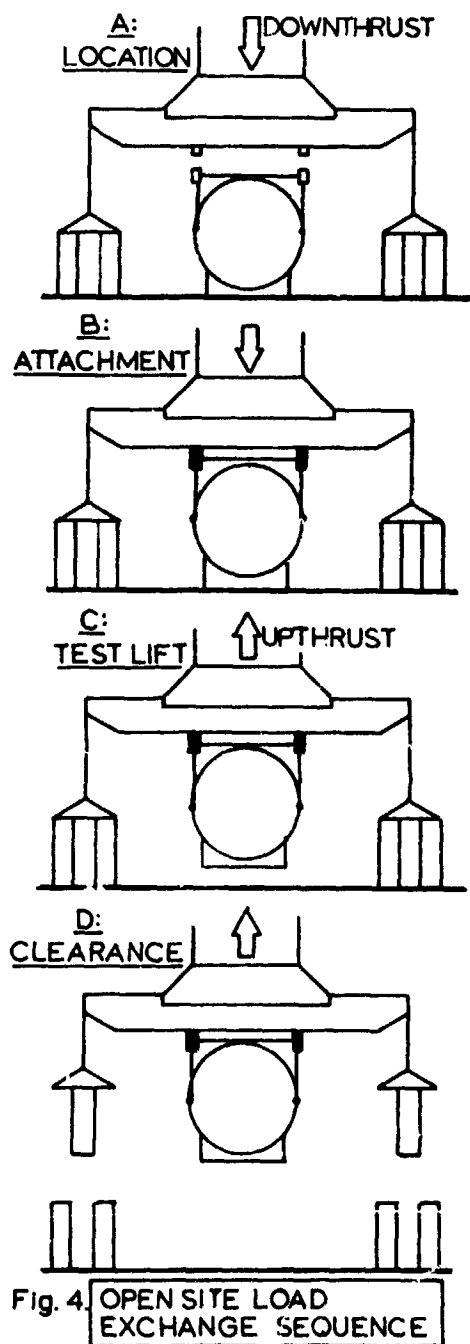

Fig.3.
 OPEN SITE LOAD
 EXCHANGE SYSTEM OF
 AIRFLOAT HL AIRSHIP

To pick up a load, the airship arrives 'in ballast', i.e. with packs of 15-tonne water containers suspended from the ballast frames, and takes up a controlled hovering position 15 to 50 m above the load according to local conditions. As the load frame is being lowered by the main hoist it is aligned with the load and the ballast packs are let down relative to the load frame so that they will touch ground first with about 1 m clearance between latches and pickups, as in Stage A of Fig 4. The ballast packs are manoeuvred into position and grounded by downthrust of the vectored propellers while the ballast winches on the load frame draw it down onto the sub frames; the latches are then engaged to attach the load (Stage B). Upthrust is now applied and the ballast winches reversed, allowing the load to rise from the ground; in this position (Stage C) the load security and c.g. may be checked before finally detaching an appropriate number of ballast units so that the airship may rise bodily with the load (Stage D), which is then hoisted up and secured in the flight position. After departure of the airship the ballast containers are emptied and taken away by ground service vehicles, which also have the



task of providing containers and setting up ballast packs at delivery sites for exchange with incoming loads; the delivery sequence is then the reverse of the pickup process outlined above. The oil-burning version of the HL ship uses further ground vehicles to supply fuel in 10-tonne fibreglass transfer tanks which are incorporated into the ballast packs in place of ballast containers; the gas versions detach and dock fuel blimps in flight wherever these may be conveniently flown into the operating circuit.

The weight of the load frame and attachments, estimated to be 30 tonne, must be deducted from the gross payloads of Fig 2 to obtain the permissible weight of the payload and its sub frames.

Module Operation

Operation between fixed bases permits the use of permanent transfer installations through which loaded modules of similar weight may be rapidly exchanged without the involvement of external ballast systems. Fig 5 indicates the components of the module system; there is now no intermediate load frame, the hoist frame engaging the upper booms of lifting beams running across the module. The permissible weight of the loaded module then becomes the gross payload plotted in Fig 2.

A standard module has been designed, 60 m long, 25 m wide and 10 m deep, which with different internal arrangements can accommodate for example 250 cars and 1 000 passengers; or 3 000 foot passengers; or 15 loaded vehicles averaging 24 tonne apiece. Smaller modules may be postulated for bulk grain and fluids, perishables and containers, though there are few applications in the latter categories where the airship may be expected to show a decisive commercial advantage over existing systems.

Different module exchange mechanisms are under consideration; the one in Fig 5 uses two transfer pools separated by a causeway which carries a ballast block, equivalent in weight to a loaded module, on a frame of adjustable height. The incoming module is lowered into its pool and held down by vectored thrust while tracking bollards move it into the exchange position, the airship following in response to control signals from a

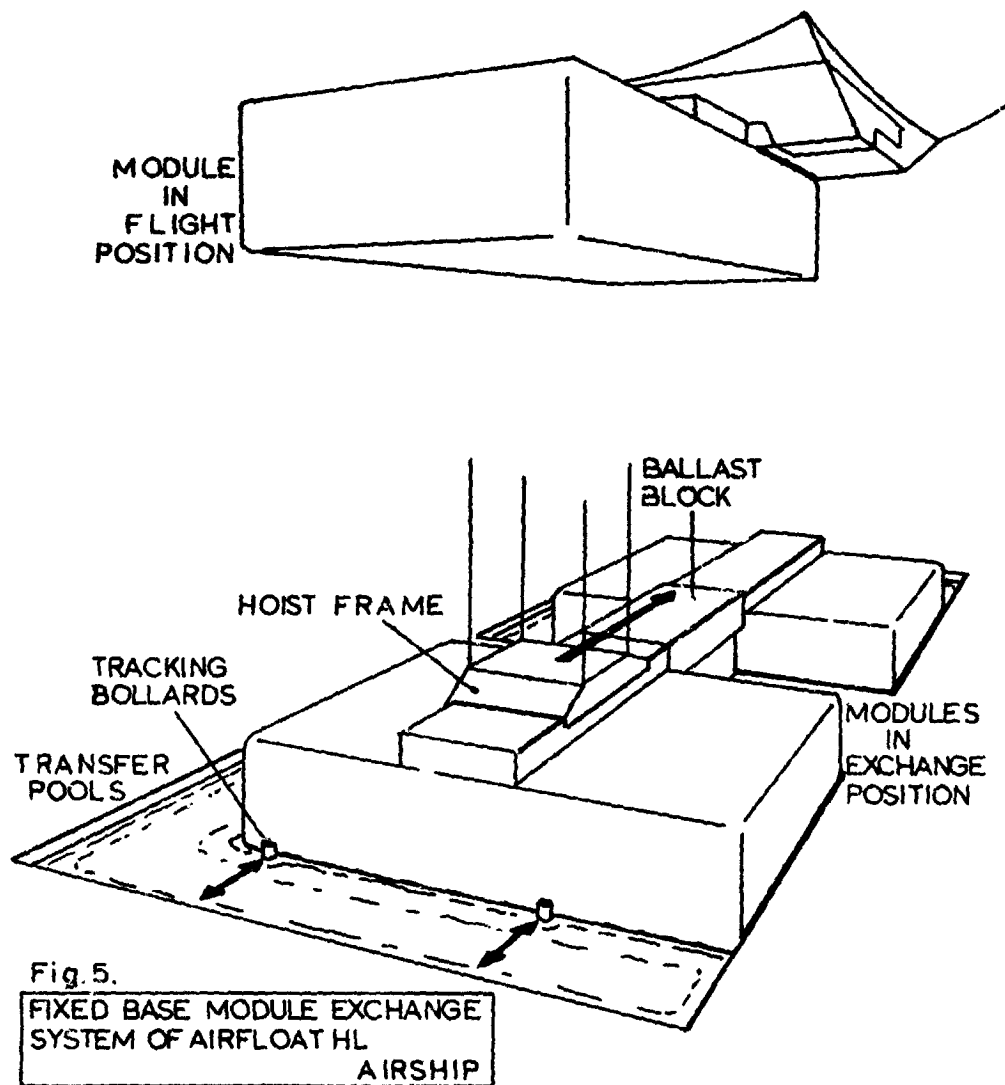

position gyro in the load frame. In the exchange position the module is coupled to the ballast block, which moves vertically to hold the module level while the hoist frame is tracked across the module and onto the block. At this stage the ballast block may, in an emergency or for some other reason, be lifted out in place of a module; in the normal transfer sequence, however, the block is now disconnected from the incoming module, coupled to the outgoing one, and again used to control the level of the latter while the hoist frame is moved onto its suspension beams. Finally the module is disconnected, moved out into the centre of its pool, and lifted clear.

Maintenance and Construction

The size of the HL airship precludes accommodation in a hangar of reasonable cost, and it must therefore live permanently in the open. For maintenance the airship is clamped

to a base turntable through its load frame and through additional stays to the engine mountings; the turntable is rotated through a control unit responding to signals from wind sensors surrounding the base, so that wind loads on the hull are kept within acceptable limits.

Construction must be carried out on the same turntable. The hull comprises an assembly of prefabricated units, each composed of two or three gas cells complete with shell structure, covering and gasbags; the latter are partially filled to reduce handling weight and to check for leaks and valve function. The units incorporating the hoist are first set up on the turntable, and further units are then added at either end so that the structure cantilevers towards nose and tail and can be turned to suit wind conditions. The hull units are lifted into place by hoists travelling along a temporary dorsal girder mounted along the top of the hull.

Safety

The most critical operating conditions arise during load transfer, and this phase has therefore received more attention than any other in the design of the HL system. The Open Site sequence allows the airship to lift either the load or the ballast clear of the site at any moment during the exchange period; an equivalent facility is offered by the ballast block in the module system, though here a critical condition arises while the hoist frame is tracking between lifting stations and the system is therefore being further examined. The failure during load exchange of any one engine will modify the control envelope, but will not require immediate withdrawal from the sequence except in severe turbulence. Flying control and computer systems are duplicated against electrical or mechanical failure.

In moving flight the principal danger, particularly when manoeuvring close to the ground, is that of structural damage and gasbag rupture due to collision with ground obstacles or light aircraft; larger commercial and military aircraft will tend to operate at higher altitudes and under stricter traffic control. The shell structure is diffuse and highly redundant, and may be expected to absorb appreciable damage in most areas without significant immediate loss of airworthiness; gasbag rupture, however, requires more attention. Each gasbag in the HL airship is divided internally by an annular membrane into two compartments, so that rupture of the outer skin cannot release more than half the gas content. In addition, 62 tonne of emergency water ballast carried in tanks at nose and tail permit balancing both of lift loss and of pitching trim loss arising from the collapse of any one gasbag or of any two half-bags.

The fire hazards inherent in gaseous fuels are met by the controlled separation techniques which have already been indicated. A burning fuel blimp may be towed on an extended cable until it burns out or can be released over a 'safe' area. Similarly, if the airship's tailcone becomes ignited the fuel blimp may be cast off and the tailcone 'trailed' on a cable until it can be safely jettisoned, running meanwhile on the kerosine reserve while the fuel blimp follows under its own power. The blimp is then reattached for continued flight.

Costs

Estimation of the capital cost of the HL airship is based upon the assumption that no initial facilities exist; the final figure, referred to current U. K. averages, therefore includes the cost of the construction site, of the accommodation, materials and personnel

for design, research, construction and crew training, and of one base turntable. A large item in the cost is a flight simulator system, to be used initially for control system development and later for crew training; the nature of the project renders simulator training more appropriate than flight training in a small airship, and no specific allowance has been made for the construction of a small vessel within the HL programme. Some use may, however, be made of any small airship which becomes available, such as one of the Goodyear or WDL blimps, or the larger Airfloat GP airship which forms the basis of a parallel project.

Exact costing is inhibited by unstable economic conditions; a comprehensive costing exercise was, however, carried out by Airfloat in 1972, and subsequent application of a suitable spectrum of inflation factors and known cost increases has led to a current estimate of about £9 000 000 (\$23 000 000) for one basic airship, using kerosine alone. There are then additional items for airship and mission variants; 3 fuel blimps and a refuelling base for the gas burning versions, ground service vehicles and facilities for open site work, 3 modules and 2 exchange terminals for module operation, leading to the following approximate capital costs:

	Open Site Operation	Module Operation
Oil-burning HL airship	£10 000 000 (\$25 000 000)	£11 000 000 (\$28 000 000)
Gas-burning HL airships	£12 000 000 (\$30 000 000)	£13 000 000 (\$33 000 000)

These costs refer to one airship; subsequent ships and their associated facilities would be expected to cost about £3 000 000 (\$7 000 000) less than the above totals.

The annual operating cost is found not to differ greatly between Open Site and Module systems, the running cost of the ground services for the former balancing that of the module terminals for the latter; there are, however, significant differences between the running costs of alternative fuel versions, and at current U.K. fuel prices the annual operating cost for a 46-week working year in a 15-year depreciation period becomes about £5 200 000 (\$13 000 000) on kerosine, £4 000 000 (\$10 000 000) on dual fuel and £3 300 000 (\$8 000 000) on natural gas alone. These figures refer to a single airship recovering the whole of its capital cost.

On Open Site work the annual capacity of one HL airship is about 450 000 000 tonne-km on kerosine and 470 000 000 tonne-km on dual fuel or gas; the corresponding figures for module operation with a module of 100 tonne tare weight are respectively 350 000 000 and 370 000 000 tonne-km. The unit capacity rates are then found to be:

	Kerosine	Dual Fuel	Gas
Open Site Operation:			
pence/capacity tonne-km	1.2	0.9	0.7
cents/capacity U.S. ton-mile	4.1	3.1	2.5
Module Operation:			
pence/capacity tonne-km	1.5	1.1	0.9
cents/capacity U.S. ton-mile	5.4	3.9	3.2

It should be emphasised that these are capacity rates estimated for construction in the U. K. and operation in Europe; their relationship with true rates will depend upon the area of operation and upon the load factors which can be achieved in the selected traffic category.