

EP-82

PLANETARY EXPLORATION

Space in the Seventies

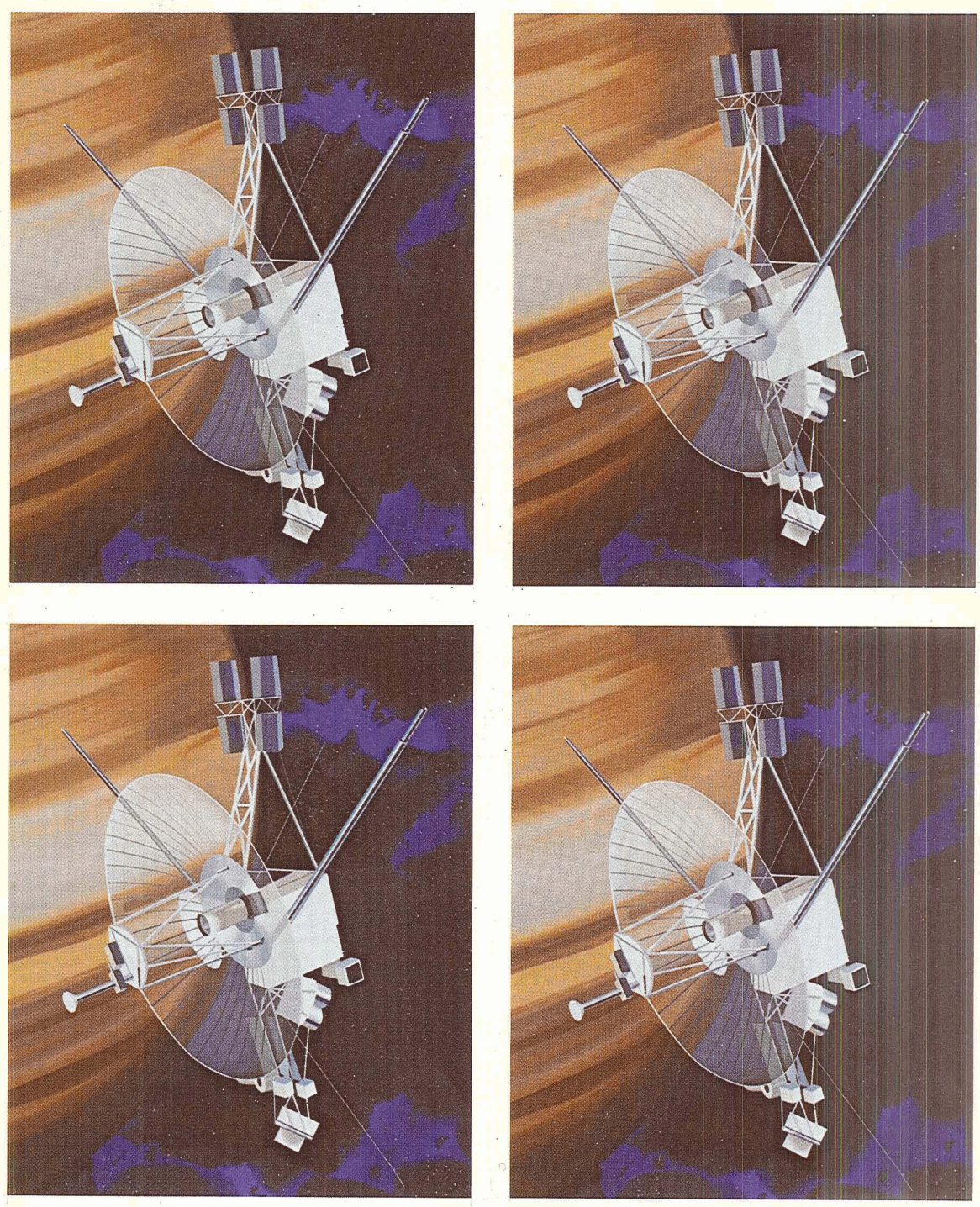

National Aeronautics and Space Administration

SPACE IN THE SEVENTIES

Man has walked on the Moon, made scientific observations there, and brought back to Earth samples of the lunar surface.

Unmanned scientific spacecraft have probed for facts about matter, radiation and magnetism in space, and have collected data relating to the Moon, Venus, Mars, the Sun and some of the stars, and reported their findings to ground stations on Earth.

Spacecraft have been put into orbit around the Earth as weather observation stations, as communications relay stations for a world-wide telephone and television network, and as aids to navigation.

In addition, the space program has accelerated the advance of technology for science and industry, contributing many new ideas, processes and materials.

All this took place in the decade of the Sixties.

What next? What may be expected of space exploration in the Seventies?

NASA has prepared a series of publications and motion pictures to provide a look forward to SPACE IN THE SEVENTIES. The topics covered in this series include: Earth orbital science; planetary exploration; practical applications of satellites; technology utilization; man in space; and aeronautics. SPACE IN THE SEVENTIES presents the planned programs of NASA for the coming decade.

June, 1971

COVER: A concept for a spacecraft to explore the outer solar system is the Thermoelectric Outer Planets Spacecraft (TOPS). (See page 23)

PLANETARY EXPLORATION

by William R. Corliss

National Aeronautics and Space Administration, Washington, D.C. 20546

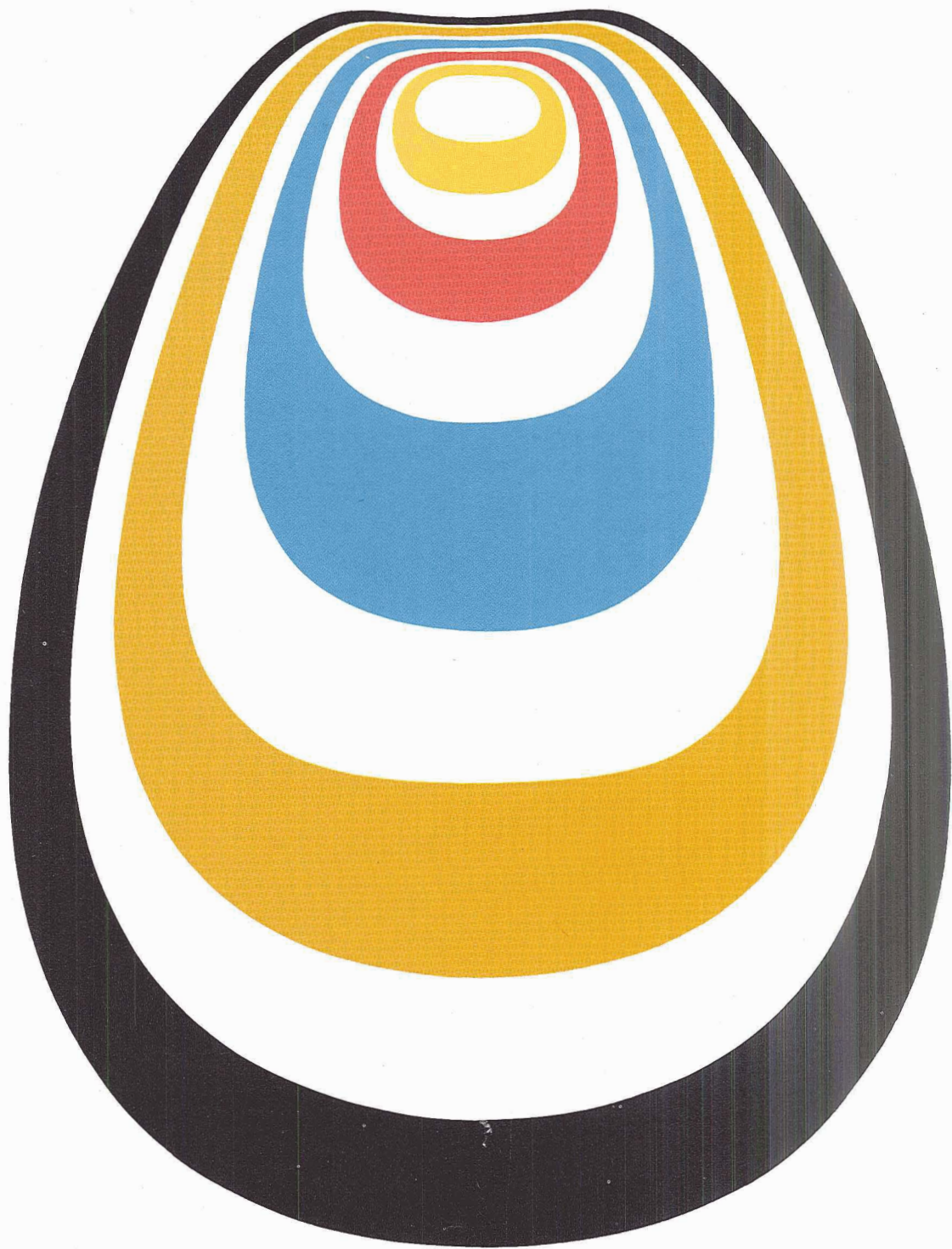

TABLE OF CONTENTS

- 4 INTRODUCTION
- 4 A STRATEGY FOR PLANETARY EXPLORATION
- 5 ORBITING THE RED PLANET—MARINER-MARS 71
- 11 MACHINES ON MARS—VIKING 75
- 17 TRAILBLAZING BEYOND MARS—
PIONEER-JUPITER 72, 73
- 22 OUTER PLANETS MISSION
- 24 AN INNER TOUR—MARINER-MERCURY/VENUS 73
- 26 CLOSEST TO THE SUN—HELIOS 74, 75
- 28 IN THE DECADE OF THE 1970S

INTRODUCTION

Seven was a mystical number to the ancients. From Babylon to Alexandria, astronomer-priests saw only seven points of light wandering across the field of fixed stars. The so-called "Sacred Seven" became a very unmystical eight when Neptune was discovered through the telescope by J. G. Galle in 1846. Now we know that there are at least nine planets, with a very slight chance that one or two more small ones are swinging slowly, undetected as yet, around the Sun at the fringes of the solar system.

Planet discovery was a passion with astronomers during the 1800s and early in this century; but today they want close-up pictures of the nine planets we already know, followed by analyses of their atmospheres and surfaces. In short, modern astronomers want to dissect and analyze the other planets just as they have dissected and analyzed the Earth over the past centuries. Whereas Ptolemy, Tycho Brahe, Kepler, and the other astronomical pioneers devoted their lives to describing planetary motion accurately, the objectives of modern planetary exploration are to:

1. Reconstruct accurately the origin and evolution of the nine planets, the asteroids, the comets, and the interplanetary medium.
2. Recount accurately the origin and evolution of life within the solar system.
3. Apply new-found knowledge of the other planets to the Earth so that we can understand it better.

The objectives of planetary exploration originate in our curiosity about the heavens and life in general. It is one portion of NASA's program that cannot be evaluated readily in dollars-and-cents terms. What would it be worth, for example, to discover extraterrestrial life? Despite the profound effect this discovery would have upon our outlook and concept of the universe, it transcends our common scheme of values. Economic justification of planetary exploration is like trying to justify the painting of the Mona Lisa or the Curies' discovery of radium. Both are priceless, yet both cost money. NASA's goal is to explore the planets, aiming at targets with high potential scientific payoff with the least consumption of national resources.

A STRATEGY FOR PLANETARY EXPLORATION

Through the telescope, the planets are fuzzy discs of light with many details swimming tantalizingly just out of reach. The space program, however, has provided science with instrument carriers that can take close-up looks with TV cameras, thermometers, life detectors, and other instruments. Already NASA's Mariner planetary fly-bys have revamped many of our ideas about Mars and Venus. The surface of Venus is an 800°F. (427°C.) inferno instead of a primitive, expectant "twin" of the Earth as astronomers once thought. Mars is pocked with craters and possesses a highly varied terrain. The planets all seem to have personalities of their own, and the solar system seems a more mysterious place than it did a decade ago. To understand our own origin and the origin of our planet, we must know the solar system's origin and evolution.

We cannot afford to launch spacecraft willy-nilly towards all planetary targets. A strategy is needed to maximize the scientific payoff within the resources available to NASA. Which kinds of spacecraft shall we send to which planets?

In order of increasing difficulty and expense, the types of planetary missions are:

1. "Fly-by" missions, in which spacecraft, such as the NASA Mariners, pass close to a planetary target and scan it with instruments.
2. Atmospheric probe missions, in which spacecraft penetrate a planet's atmosphere but are destroyed upon impact. Example: the Russian Venera probes.
3. Orbiter missions, where spacecraft survey the planet from orbit. NASA's Lunar Orbiters typify this class.
4. Lander missions, where the spacecraft softlands on the surface and radios data back to Earth. Example: America's lunar Surveyor spacecraft.
5. Sample-returning, unmanned missions, during which atmospheric and surface samples are acquired and brought back to Earth.
6. Returning, manned lander missions, such as the Apollo flights to the Moon. These are difficult and costly.

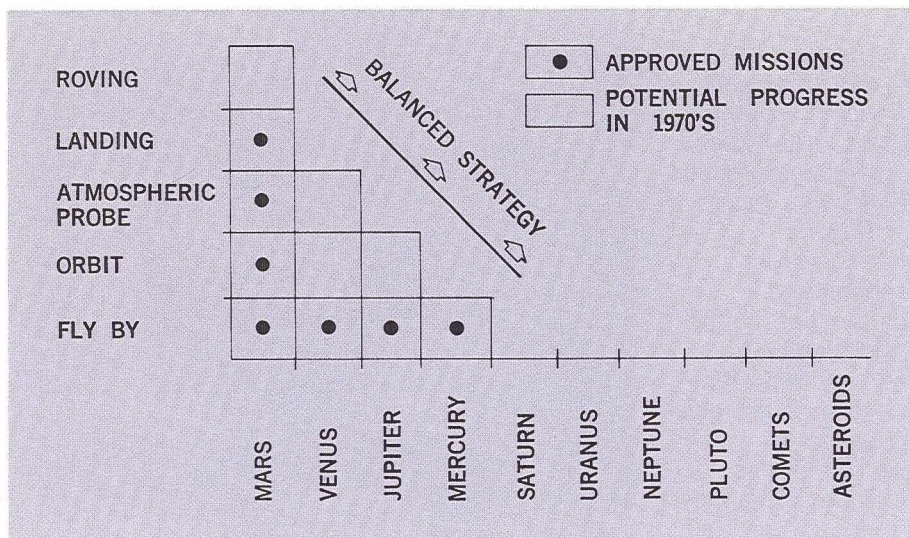

Figure 1. NASA's balanced strategy of planetary exploration.

Only the first four types of missions fall within the limitations of NASA's planetary exploration budget and technical capability during the decade of the 1970s.

Given the above mission types, where should we aim the spacecraft? Because of its nearness and the still lingering possibility that life may exist there, Mars is the primary target of NASA. But spacecraft will also be dispatched inward toward Mercury and outward toward Jupiter. NASA terms this a "balanced strategy" because it focusses on the target of greatest interest, Mars, yet it still brings two new planets under terrestrial surveillance, Mercury and Jupiter. (Fig. 1) The approved missions are summarized in Table 1.

ORBITING THE RED PLANET MARINER-MARS 71

One of the most popular books ever written about Mars was Percival Lowell's *MARS AND ITS CANALS*. It was published in 1906, when the whole world was agog over the intricate network of canals that

Lowell was mapping through his telescope at Flagstaff, Arizona. Newspapers were full of speculation that Mars was inhabited by an intelligent race that was slowly perishing as its meager supplies of water dwindled. From our superior technical vantage point, we no longer expect significant amounts of water on Mars and probably no intelligent life; but Mars remains enigmatic in many ways.

Three Mariner spacecraft have flown past Mars: Mariner 4, in 1964, and Mariners 6 and 7, in 1969. They radioed back pictures, not of great artificial waterways but rather of a highly diverse landscape, chaotic here, cratered there, featureless elsewhere. Mariners 6 and 7 sent back over 200 photos along with more than 5000 ultraviolet and infrared spectrograms of Mars. To say the least, the geology of Mars was hardly what astronomers had expected. Mars has some terrestrial features, some lunar similarities, too, but we must consider it a unique planet, like nothing else in the solar system. The following "Martian Mysteries" support this view.

TABLE 1. Approved NASA Planetary Missions, 1970*

Target Planet	Spacecraft Type	Launch Date	NASA Center
Mars	Mariner orbiters	1971	Jet Propulsion Laboratory
Mars	Viking orbiters and softlanders	1975	Langley Research Center
Venus/Mercury	Mariner fly-by spacecraft	1973	Jet Propulsion Laboratory
Jupiter	Pioneer fly-by spacecraft	1972-1973	Ames Research Center

*NASA also supports the HELIOS solar probe project of West Germany as well as a program of terrestrial planetary astronomy.

Some Unsolved Martian Mysteries

1. How was the chaotic Martian terrain created? (Fig. 2) Some small earthquake-ravaged areas of the Earth show similar signs of violent upheaval.
2. There seem to be two distinct, yet intermixed, populations of craters; one group, old and eroded; the other, young and sharp. What could have caused the two bombardments? (Fig. 3)
3. How did the wide stretches of featureless terrain escape the meteoric cannonades?
4. The Hellas region—300,000 square miles of the Martian surface—is now one of the brightest features of Mars. In 1954, it was very dark. Why?
5. Dark-floored craters and dark patches often give terrestrial astronomers the impression of straight lines (canals), which are sometimes doubled and often thousands of miles long. How could seemingly random phenomena create such neat, geometrical networks?
6. What causes the “waves of darkening” that sweep toward the Martian equator as summers melt the carbon-dioxide polar caps? Is this a manifestation of some form of life or just a chemical reaction on the surface? Or is it neither?
7. What causes the great yellow clouds? In 1877, 1909, 1922, and 1956, much of the face of Mars was obscured by these clouds while the planet was closest to the Sun.
8. Many terrestrial microorganisms do quite well in a simulated Martian environment. Is there life on Mars?

A Martian Strategy. Any one of the above questions is intriguing enough to warrant sending more spacecraft to Mars. The question of life in particular, has far-reaching philosophical connotations. Three unmanned Mariners have flown by Mars; what should be the next step? NASA's basic strategy is similar to that it employed so successfully in lunar exploration; namely, the following sequence of ever-more-sophisticated spacecraft: fly-by, orbiter, unmanned lander, and manned lander.

In keeping with this philosophy, NASA scheduled two orbiters, Mariners H and I*, to follow the 1965 and 1969 flyby successes. But Mariner H fell victim



Figure 2. The Mariner 6 flyby took this picture of chaotic Martian terrain. Areas on Earth hard hit by earthquakes sometimes show the same kind of slumping and upheaval.

Figure 3. This mosaic of photos snapped by Mariner 6 indicates that cratered terrain dominates on Mars.

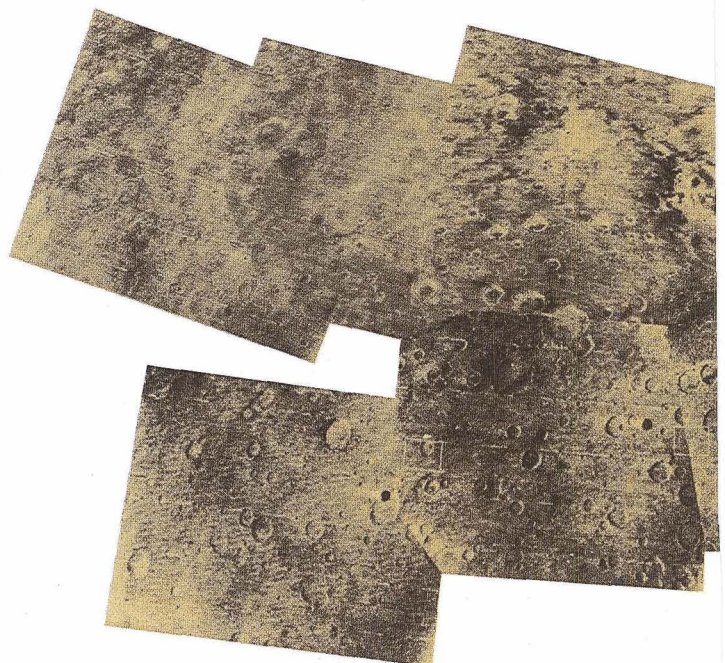

*NASA spacecraft are designated by letters before launch. If the launches are successful, they are assigned numbers.



to a failure of the Centaur stage of the Atlas-Centaur launch vehicle; although its designation became Mariner 8 it did not achieve a trajectory towards Mars. Mariner 9 (Mariner I) was successfully launched on May 30, 1971 and scheduled to arrive at Mars November 13, 1971.

The Viking landers will follow in 1975 according to current plans. Manned flights similar to the Apollo lunar missions may be attempted in the 1980s. Mariner 9 will give scientists a long look at the Martian surface and help them select propitious

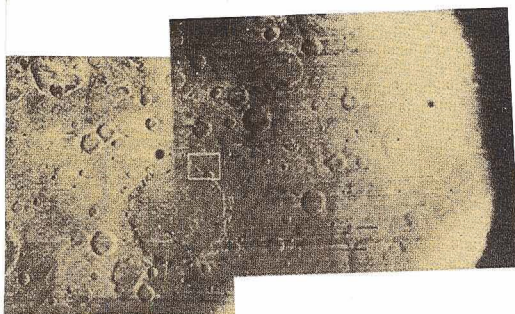

targets for the Viking landers. The sequence is essentially the same as the Lunar Orbiter-Surveyor Lander interlocking missions to the Moon.

The Mariner-9 orbiter is more than just a trail-blazer for the Vikings. It will carry out a mapping mission of the Martian surface and will also study features of Mars that vary with time, such as those areas engulfed by the annual wave of darkening.

The plan is logical, but we should bear in mind that terrestrial logic may be superseded once the spacecraft arrives at Mars. For example, early photos may reveal "targets of opportunity" that call for special attention. For this reason Martian missions are flexible in design.

Mariner Sketch. The long line of successful Mariner spacecraft began at the Jet Propulsion Laboratory (JPL) in the late 1950s. In addition to the Mars fly-by missions already mentioned, Mariners 2 and 5 reached Venus in 1962 and 1967. (Mariners 1 and 3 were victims of a launch vehicle failure and a shroud-jettison failure, respectively.) When one considers that the Mariners have to cruise for about six months through space before reaching their targets and then, in a few supercharged hours, scan the planet with several instruments, they have done very well indeed.

Superficially, the Mariners all look alike. (Figs. 4 and 5) Wing-like solar paddles extending from a central equipment compartment characterize the species. Another common element is the dish-shaped, high-gain radio antenna that must be pointed at the Earth for telemetry transmission, command reception, and radio tracking. At the top of the spacecraft, a maneuver engine pokes its nozzle along the spacecraft axis. The sides of the spacecraft are usually occupied by star trackers, auxiliary antennas, pressure tanks, and the window-blind-like louvers that control the temperature inside the spacecraft electronic compartments. The scientific "eyes" of the spacecraft are located on the bottom on a movable platform. As the spacecraft approaches its target, the scan platform keeps the scientific instruments pointed toward the planet.

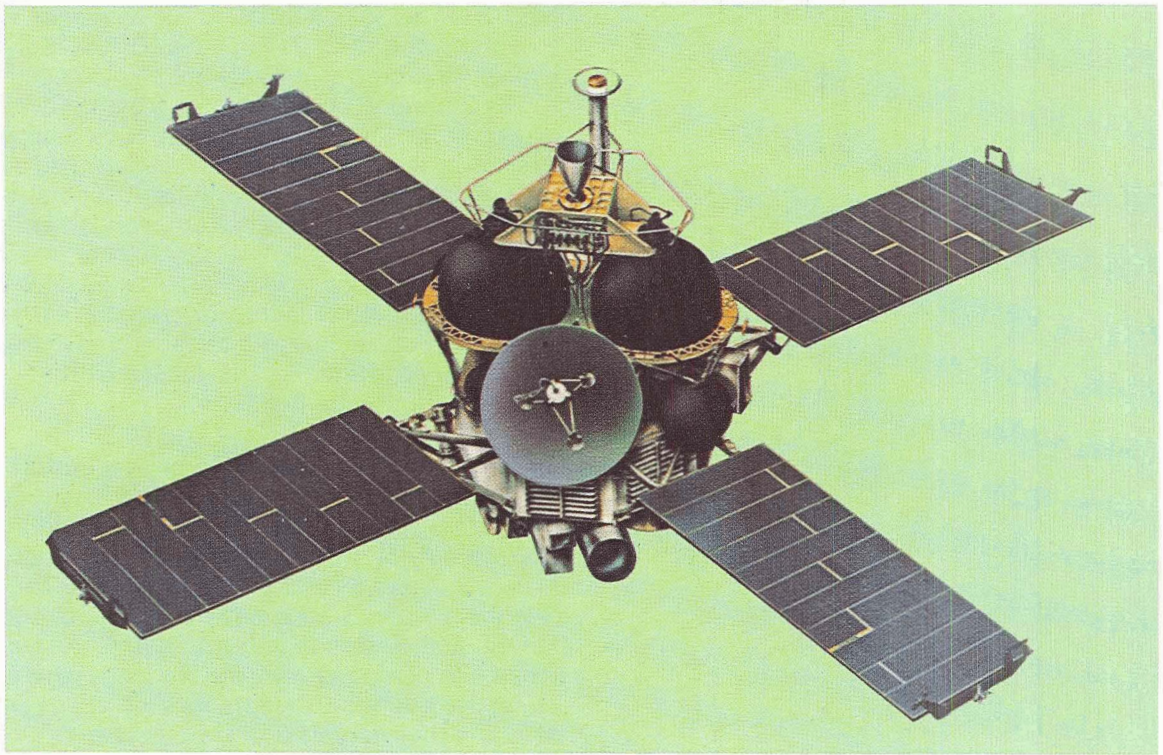

Figure 4. Top view of Mariner-Mars 71.

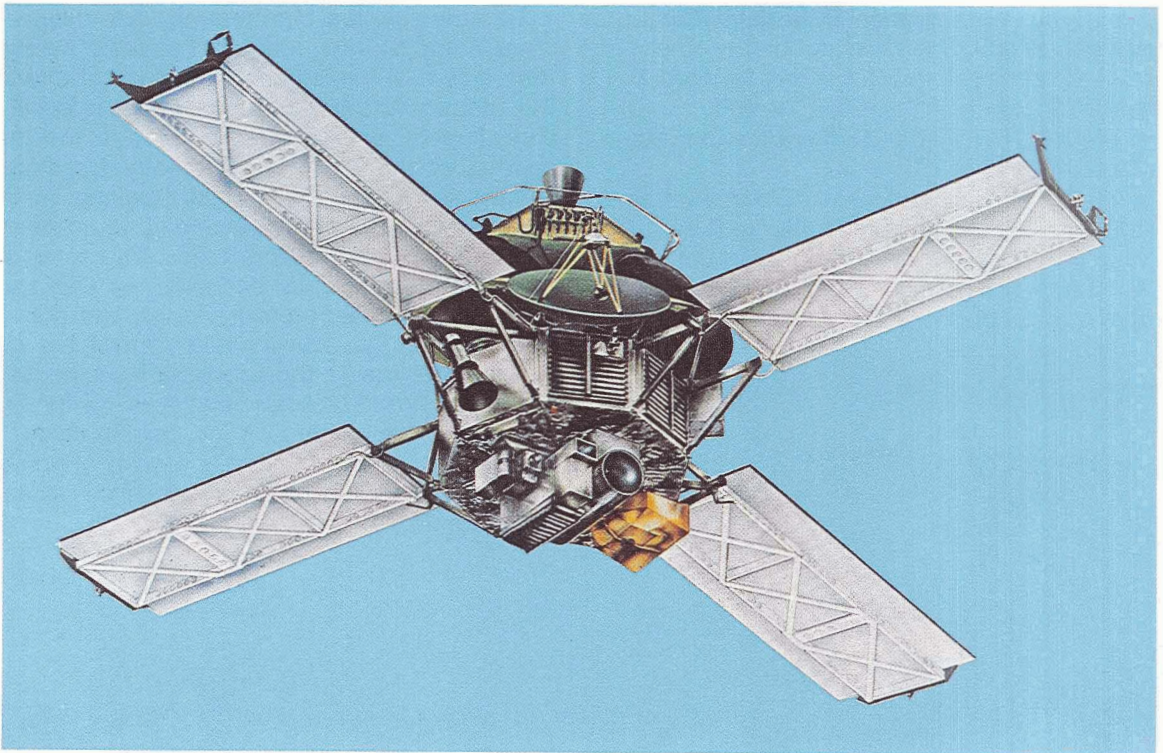

Figure 5. Bottom view of Mariner-Mars 71 showing instrument placement. (Some insulation has been removed to present a better view.)

Down the years, the Mariners have been refined bit by bit. The important features of the 1971 Mariners are presented in Table 2.

Studying Mars from Orbit. The Mariner television cameras which will sweep the still-enigmatic Martian terrain will be the primary instruments aboard the orbiter. Scientists and laymen alike want a good close-up view of Mars. However, a great deal can also be learned about the planet's atmosphere and surface by analyzing the electromagnetic radiation reflected from and emitted by the planet below. Infrared radiation from the Martian surface, for example, is a measure of surface temperature at a distance; solar ultraviolet rays are strongly affected by the different gases in the Martian atmosphere. By mapping Mars in the infrared and ultraviolet as well as the visible portion of the spectrum, scientists hope to learn more about possible volcanic activity, atmospheric

structure, and zones conducive to life. Astronomers have tried to map Mars' tiny disc through the telescope for decades at all wavelengths. Now, at long last, most of the Martian surface will be a wide panorama only 1000 miles below their instruments. These instruments are described briefly in Table 3.

TABLE 2. Design Features and Vital Statistics, Mariner-Mars 71

Spacecraft Functions	Design Features
Communication and data handling	Forty-inch paraboloidal, high-gain antenna pointed at Earth. Tape recorder used when instruments acquire data faster than transmitter can send them.
Power supply	Four solar panels with total area of about 83 square feet provides 800 watts of power near the Earth and 450-500 watts near Mars. Battery with 600 watt-hour capacity provides for critical spacecraft maneuvers and shadow periods.
Attitude control	Sun sensor and star tracker (using Canopus as guide star) tell spacecraft its orientation in space. Two systems of gas jets can: (1) Point the solar panels toward the Sun (cruise phase of flight); (2) Point the maneuver engine in the proper direction to make mid-course corrections and insert the spacecraft into Martian orbit; and (3) Orient the spacecraft for surveying the Martian surface.
Propulsion	A 300-pound-thrust, restartable maneuvering engine. Fuel: monomethyl hydrazine. Oxidizer: nitrogen tetroxide.
Structure	Central compartment (Figs. 4 and 5) is a magnesium framework with eight equipment bays. Solar panels are hinged to the framework and are unfolded once in space. With solar panels extended, spacecraft measures 22 feet 7.5 inches across. Total weight at launch: about 2150 pounds; weight at Mars: about 1200 pounds due to maneuver engine fuel consumption.
Launch vehicle	The Atlas-Centaur.
Tracking and data acquisition network	The Deep Space Network, with 85-foot and 210-foot paraboloids for tracking, data acquisition, and sending commands from Earth-based controllers.

TABLE 3. Scientific Instrumentation, Mariner-Mars 71

Instrument	Scientific Objectives	Principal Investigator(s)
Two TV cameras; one narrow angle, high resolution (0.1 km); one wide angle, with 1.0 km resolution.	Detailed mapping of the planet's surface, especially the wave of darkening, the polar caps, the nightside atmosphere, surface fluorescence, haze, cloud cover, and dust clouds.	H. Masursky (U.S. Geological Survey); G. de Vaucouleurs (U. Texas); J. Lederberg (Stanford); B. Smith (N. Mex. State U.); W. Thompson (Bellcomm Inc.)
Ultraviolet spectrometer; two channels, 1700-3400 and 1100-1900 Angstrom units.	Measure local atmospheric pressures. Pinpoint ozone concentrations (as possible indicators of biological activity). Map the structure and composition of the upper atmosphere and ionosphere.	C. Barth (U. Colorado)
Infrared interferometer spectrometer; range 6-50 microns.	Measure vertical temperature profiles, composition, and dynamics of atmosphere. Measure the temperature, composition, and thermal properties of surface materials, with special emphasis on potential biological materials, such as vegetation.	R. Hanel (Goddard Space Flight Center)
Infrared radiometer; two channels, 8-12 and 18-25 microns.	Map the temperature of the surface as a function of local time, with special attention to "hot spots" indicative of internal heat sources.	G. Neugebauer (California Institute of Technology)
Radio occultation experiment (no specific instrument)	Measure variations in the atmosphere and ionosphere by noting how the spacecraft transmitter signals are affected as the spacecraft swings behind the planet.	A. Kliore (Jet Propulsion Laboratory)
Celestial mechanics experiment (no specific instrument)	Improve our knowledge of solar system distances, astronomical constants, the mass of Mars, and relativistic effects.	J. Lorell (Jet Propulsion Laboratory), I. Shapiro (M.I.T.)

The Long Cruise to Mars. The famous Martian canals were first publicized by Giovanni Schiaparelli while he was making a high precision map of Mars during 1877, when Mars approached to within 34.8 million miles of Earth. These favorable approaches or "oppositions" occur about every 26 months, but some, like that of 1877, are much better than others. In 1971, the distance of closest approach will be 34.9 million miles—almost as good as that in 1877. Shortly after the 1971 opposition Mariner 9 should be in orbit around Mars to complement telescopic observations.

In the original plan, two Mariners were to have been launched from Cape Kennedy during a 28-day launch window which began in early May 1971. The second would have followed the first after about 10 days. But Mariner 8, although successfully launched from the pad, landed in the Atlantic Ocean when the launch vehicle failed. Launch of the

second spacecraft was delayed pending investigation of the launch failure and the revision of the Mariner 9 mission.

Scientists naturally wished to rearrange priorities and accomplish some of Mariner 8's objectives with Mariner 9. The new plan accommodated all of the originally planned experiments from both flights, but with a reduction in the amount of data transmitted back to Earth from each experiment.

Mariner 9 left the launch pad at Cape Kennedy at 6:23 p.m. E.D.T. on May 30, 1971; it was scheduled to go into orbit around Mars on November 13. Already headed towards Mars at the time were two Soviet spacecraft—each weighing about five tons as compared with 2,200 pounds for Mariner 9. There was no announcement from the Soviets about the character of the missions undertaken.

The revised mission of Mariner 9 called for an orbit around Mars with a period of 12 hours,

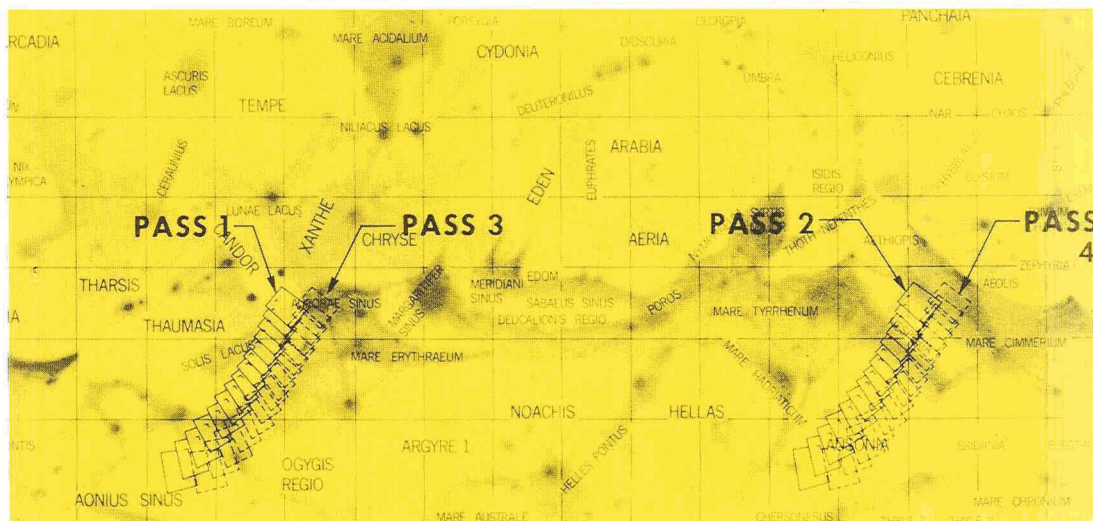

Figure 6. Mariner 9 will be placed in a Martian orbit that permits systematic camera mapping of much of the surface. The four passes above illustrate how photographs should overlap.

MACHINES ON MARS—VIKING 75

periapsis (closest approach) of 750 miles, apoapsis of 10,700 miles and inclination of 65 degrees to the Martian equator. This orbit was selected to enable the spacecraft's television cameras to obtain a map covering about 80 percent of the Martian surface.

The basic mission for Mariner 9 is to obtain data from orbit around Mars for at least 90 days. This contrasts with the brief glimpses a few hours long obtained from the three preceding Mariner missions to Mars. With thousands of new pictures plus infrared and ultraviolet maps of Mars, scientists will be able to refine their theories about the planet—this is the least we can expect. Actually, we should “expect the unexpected” for we really know very little about Mars; far less than we did in the case of the nearby Moon and our astronauts have brought back many surprises from there. Mars, with its puzzling terrain, the planet of innumerable science fiction stories, still has many secrets.

After the Mariner orbiter has mapped the Martian surface in 1971, Mars will receive no further mechanical visitors from Earth until mid-1976 when the first Viking spacecraft closes with the planet. The next logical step in NASA's Martian strategy, the Vikings will be combination orbiter-landers; that is, double spacecraft, one part remaining in orbit while the other descends onto the Martian surface.

Can the Viking landers help us answer the other questions science poses about Mars (see list above). Undoubtedly they can because they will carry experiments right down to the surface where instruments can make direct analyses of the atmosphere and surface materials. Like the Surveyor lunar landers of the late 1960s, the Vikings will carry mechanical arms which can retrieve and manipulate Martian soil and rocks, or whatever else happens to be on the surface—possibly small organisms or simple plants. Frankly, scientists do not know exactly what to expect. Mars does resemble our cratered Moon from 10,000 miles out. But, at this distance, the Earth itself appears lifeless, watery, and a display of perplexing clouds and color changes. The Viking landers, nevertheless, will carry several biological experiments—just in case.

The Double Spacecraft. The Viking orbiter and lander work together, just like the Apollo Command Module and Lunar Module have done, except, of course, that there is no orbital rendezvous and return to Earth. Viking orbiter-lander teamwork takes three forms: (1) The orbiter cameras and other instruments help select the landing sites; (2) The same instruments maintain surveillance of the planet and help the lander synchronize experiments with variable planetary phenomena, such as an onrushing wave of darkness or a dust cloud; and (3) The orbiter is a vital communication relay point for the lander until it establishes an independent communication link with the Earth.

By the time the Vikings are launched in 1975, the orbiter portion should have proven itself during the 1971 Mariner flights. The Mariner 71 design is a good basic building block, but changes will be substantial. The orbiter's diameter will have to grow because it must be capable of carrying the lander and inserting it into Martian orbit. (Fig. 7) Further, electrical power loads and data streams will be larger due to the heavy dependence of the lander upon the orbiter. The major changes made from the basic Mariner 71 design include:

- Approximately three times as much propulsive

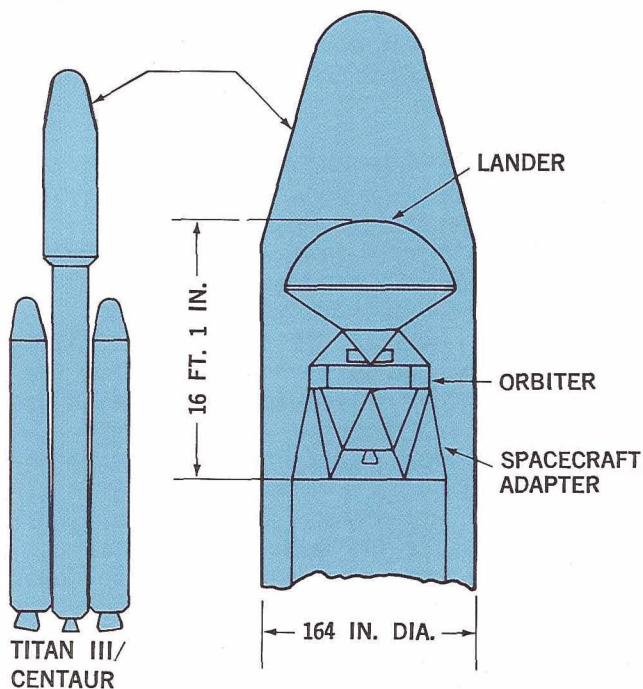

Figure 7. The Viking spacecraft inside the launch vehicle shroud. The "canned" lander is on top of the orbiter.

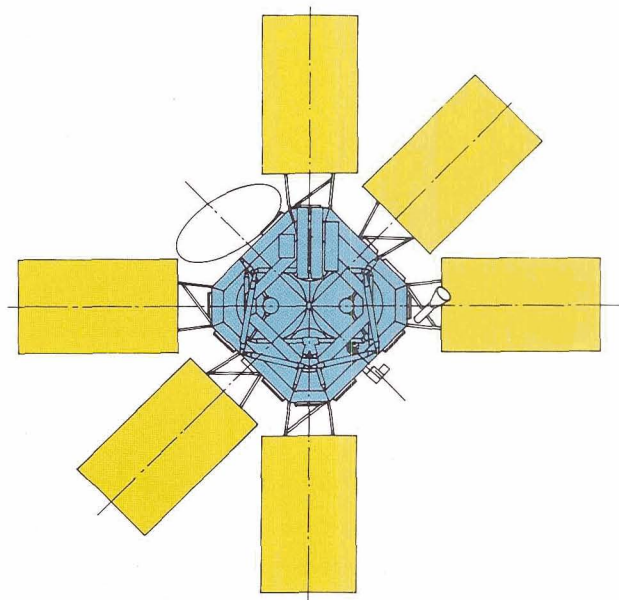

Figure 8. The Viking orbiter has the basic Mariner configuration; however, two solar panels have been added to provide the extra power needed for the more complex Viking mission.

- capacity for orbital insertion at Mars due to mass of lander and the increased mass of the orbiter
- Larger structure to carry the lander and the large amount of fuel required for planetary orbit insertion.
- Solar-cell panels increased from four to six (Fig. 8)
- Battery capacity upped
- Equipment compartment enlarged; 16 instead of 8 bays
- New receiver to pick up lander transmissions for relay to Earth

The Viking lander is an entirely new spacecraft, although technology has been borrowed from the Surveyor and Apollo lunar landers. The lander's configuration has been shaped by the tasks it must perform. The deorbit and landing phases are very influential. (Fig. 9) Following separation from the orbiter, deorbiting engines slow the lander down so that it falls toward Mars along its entry trajectory. Mars possesses an atmosphere, albeit a thin one, and at an altitude of about 150 miles aerodynamic braking begins. Nearer the surface, a parachute will slow the craft still further. At about 3900 feet from the surface, the parachute

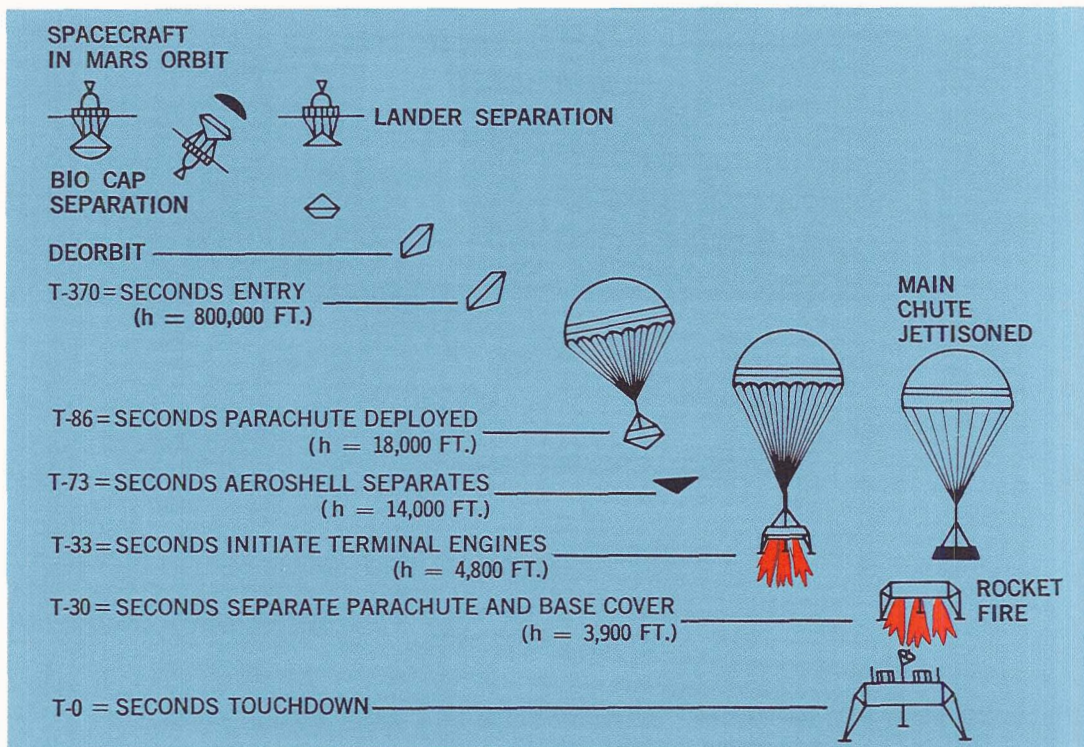

Figure 9. The Viking entry profile, showing events from lander separation through soft landing.

is cut loose and the terminal descent engines ease the spacecraft down to the surface, where shock absorbers cushion the impact of landing. These maneuvers dictate much of the lander's equipment—engines, guidance and control devices, landing gear, etc.

Another big factor in lander design is the geometry of the "can" (bioshield) that seals the heat-sterilized lander and prevents later reinfection from the orbiter and rocket gases. The can consists of two lens-shaped shells (Fig. 10), which are shed prior to deorbiting and remain in orbit. The sterilized lander then plunges

through the thin Martian atmosphere and, braked by parachutes, settles to the surface without a cargo of microscopic terrestrial invaders. Because the Martian environment may harbor life of its own, NASA wishes to avoid infecting it with Earth microorganisms which would confuse the search for indigenous life. NASA's planetary quarantine guidelines for the first Viking landing mission state

Figure 10. The lander is encapsulated by the bioshield and aeroshell during the long flight to Mars.

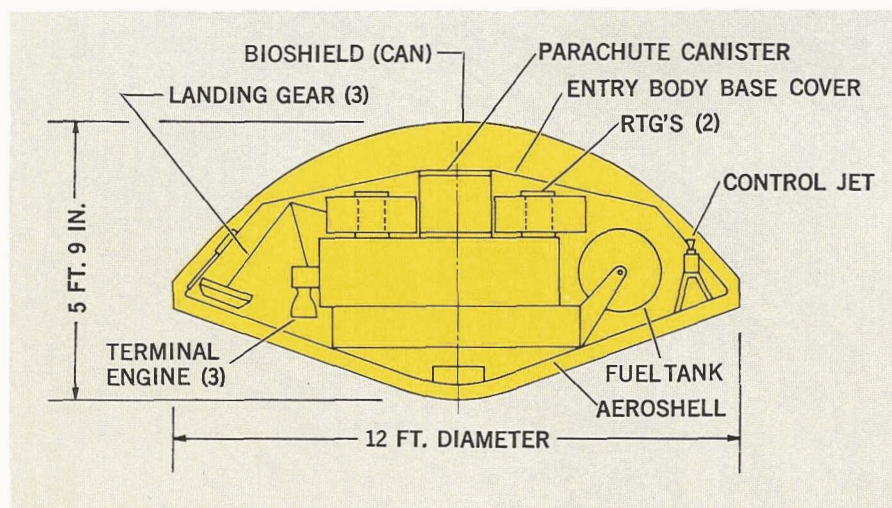

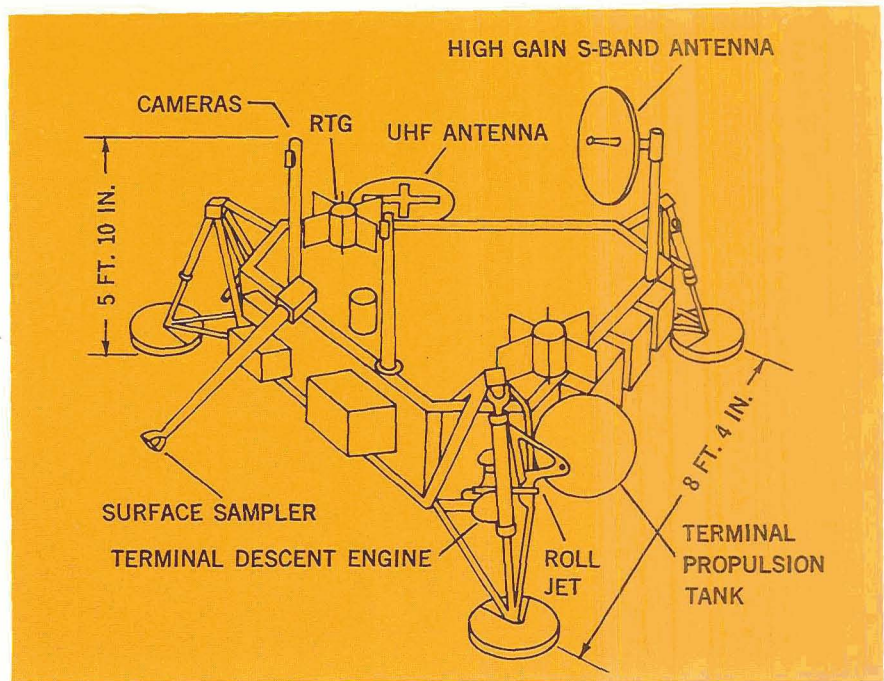

Figure 11. The Viking lander with all appendages deployed on the Martian surface.

that the probability of infecting Mars with terrestrial life must be less than three chances in one hundred thousand.

Basically, the Viking lander is a triangular "box" about 8 feet 4 inches from center to center of the tripod-like landing "feet." (Fig. 11) Many spacecraft components are packed inside the box, but fuel tanks, cameras, power supplies, and antennas are mounted externally. The major subsystems are described briefly in Table 4.

Scientific Outpost on Mars. The scientific interest in Mars is so high that NASA received 165 proposals for Viking experiments. After rigorous evaluation, 25 were selected for the payload. As the spacecraft and instruments are designed in detail, minor changes will undoubtedly be made.

The payload selected is large, even larger than most Earth satellites. Only NASA's Orbiting Geophysical Observatories can match this total. The

scientific value of a large, diverse payload of instruments is obvious, but there are two sobering practical considerations: (1) the data stream directed toward the Earth is broad and deep (about 8000 bits per second near opposition, or about 1000 times that of Mariner 2 in 1962); and (2) the many instruments make the spacecraft more complex. However, NASA has had considerable experience in both areas with its orbiting observatories and Apollo spacecraft.

TABLE 4. Design Features and Vital Statistics, Viking 75

Lander Functions	Design Features
Communication and data handling	Ultra High Frequency (UHF) transmitter and omnidirectional antenna for relaying data to orbiter overhead. S-band (about 2300 MHz) transmitter and 30-inch paraboloidal antenna for direct telemetry link to Earth after completion of landing phase. Tape recorder and magnetic-core memory store data during entry blackout and when Earth cannot be reached. Commands from Earth may be received by either the omni antenna or the paraboloid.
Power supply	Two radioisotope thermoelectric generators (RTGs) using the heat from decaying plutonium-238 deliver about 50 watts of constant electric power. The RTGs also supply heat during the cold Martian night. Batteries provide power during entry and landing and thereafter during peak loads.
Propulsion and attitude control	Eight small hydrazine jets around rim of aeroshell orient lander for deorbit maneuver. Each jet delivers about 10 pounds of thrust. Four of these jets provide the deorbiting impulse. Six different hydrazine jets on the bottom of the lander control its attitude during terminal descent. Three 600-pound-thrust hydrazine engines slow the craft to a soft landing. (Figure 12.)
Guidance and control	Radars measure the altitude and rate of descent. Gyroscopes and accelerometers help determine lander attitude. These data are fed to a computer which controls the engines and jets described above. (Control from Earth is impossible because radio signals require almost 40 minutes for a round trip.)
Structure	"Canned" lander measures about 12 feet in diameter and 5 feet 9 inches high. It weighs about 2200 pounds. As described in text, the lander is a triangular box about 8 feet 4 inches on a side.
Launch vehicle	The Titan-Centaur
Tracking and data acquisition network	The Deep Space Network, with 85-foot and 210-foot paraboloids for tracking, data acquisition, and sending commands from Earth-based controllers.

*Some of these data, particularly weights, may change slightly as design and fabrication proceed.

TABLE 5. Scientific Instrumentation, Viking 75

Lander Instrument Group	Typical Experiments and Instruments	Scientific Objectives
Entry science	Mass spectrometer Plasma analyzer	Measure the composition of the upper atmosphere. Measure the ion and electron densities and energy distribution in the upper atmosphere.
	Accelerometers, pressure sensors, temperature sensors	Measure the density, pressure, and temperature distribution in the lower atmosphere.
Meteorology	Pressure sensors and temperature sensors Wind speed and direction sensors Water-vapor detectors	Measure atmospheric pressure and temperature at the surface. Measure wind speed and direction. Measure Martian humidity.
Seismology	Seismograph	Measure seismic activity of Mars.
Imagery	Camera (two per spacecraft) (Fig. 13)	Transmit pictures of the Martian surface to Earth, including meteorological, geological, and biological phenomena. Monitor soil sampler operations. (Fig. 14)
Organic analysis	Gas chromatograph, mass spectrometer	Measure the molecular weights of compounds retrieved by soil sampler
Biology	Carbon-dioxide fixation experiment Labeled release experiment Light-scattering experiment Gas-exchange experiment	Detect photosynthetic and respiratory fixation of isotopic carbon dioxide by soil sample. Detect the release of volatile tagged compounds from incubated soil samples. Detect changes in turbidity (cloudiness) of aqueous suspension of soil sample due to biological activity. Detect changes in gas composition over incubated soil sample.
Water mapping	Infrared monochromometer	Measure the water abundance distribution in the atmosphere
Thermal mapping	Infrared radiometer	Determine variation in surface temperature and thermal balance
Radio Science	Orbiter and lander radios and ground tracking stations	Measure solar system constants more accurately. Perform General Relativity experiment. Atmosphere determination by occultation. Determine surface reflection.

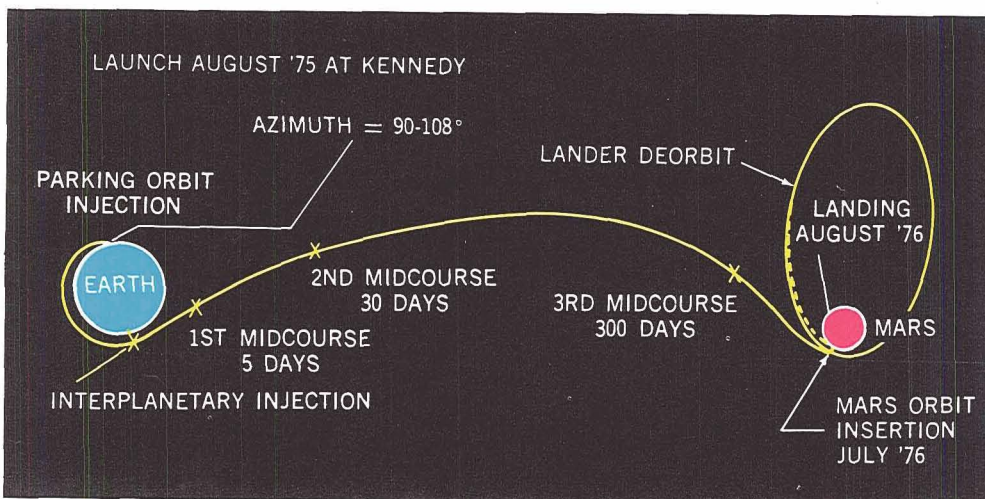

Figure. 12. A typical Viking mission profile.

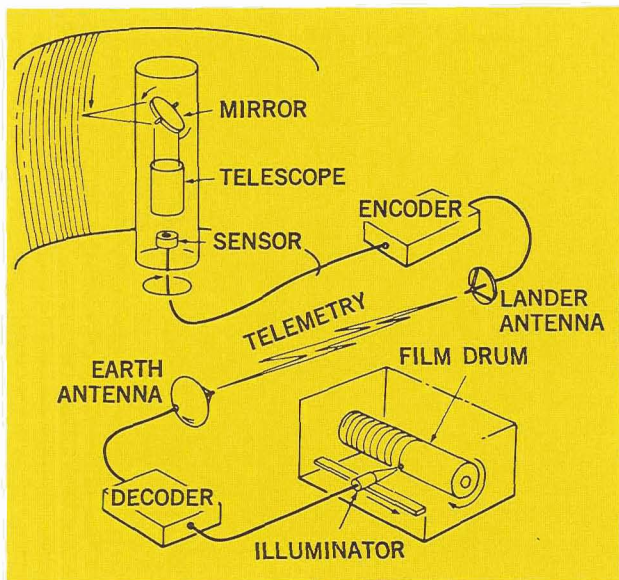

Figure 13. Schematic showing how pictures taken by the Viking TV camera are transmitted to Earth.

It is premature to attempt a definitive description of the lander's instruments because most are still in the development stage. In Table 5, some of the broad features of the experimental payload are sketched out.

1975 Is Harder Than 1971. The opposition of 1975 will bring Mars to within 52.4 million miles of Earth, considerably more than the 34.9 million miles for the 1971 opposition. The propulsive energy requirements per pound of spacecraft weight are almost doubled. So as not to exceed the capability of the launch vehicle, a new trajectory will be used. In the new trajectory, the leg of the transfer ellipse connecting the orbits of Earth and Mars will require almost a year of flight time rather than the 192 days or so for the 1971 Mariner orbiters.

The planned Viking mission profile (Fig. 12) calls for a launch using the Titan-Centaur in August 1975. The Centaur upper stage will propel the orbiter-lander combination out of an Earth parking orbit into the interplanetary transfer ellipse for Mars. In July 1976, the Viking will encounter Mars, and the orbiter's engine will insert the craft into an ellipse around Mars. After orbit trimming by the maneuver engine and the selection of a landing site using data taken by the orbiter's instruments, the lander will be separated from the orbiter in preparation for its descent to the surface. (Fig. 9)

Plans call for two Vikings to be launched in 1975. Both the orbiters and landers are being designed for three months of operation after the landing on Mars.

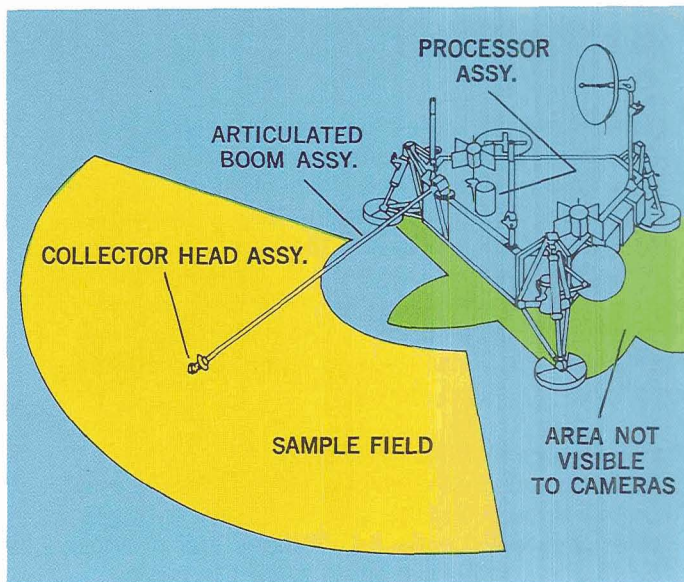

Figure 14. The Viking surface sampler will be able to retrieve soil and rock samples between 3 and 10 feet away over an azimuth of about 120°.

TRAILBLAZING BEYOND MARS PIONEER-JUPITER 72, 73

To a spacecraft heading away from the Sun, Mars is the last of the terrestrial planets, so-called because Mercury, Venus, and Mars have certain things in common with the Earth, such as small size and high density. Just beyond Mars lies the asteroid belt with its uncounted millions of bits and chunks of matter varying from dust-size specks to the planetoid Ceres, 480 miles in diameter. This curtain of debris separates the terrestrial planets from the giants of the solar system, Jupiter, Saturn, Uranus, and Neptune. The ninth planet, Pluto, is so small and far away that we hardly know how to classify it. Possibly it is an escaped moon of Neptune. Beyond Pluto, who knows what we shall find? (Incidentally, Neptune is now the most distant planet from the Sun and will remain so until 2009. Pluto's orbit is rather eccentric and when it is closest to the Sun, it is actually inside Neptune's orbit.)

Jupiter is the nearest and the biggest of the giant planets. Much of what we learn about Jupiter's structure and composition will probably also apply to Saturn, Uranus, and Neptune. It is a fitting target for our first probings beyond Mars.

Through the telescope, Jupiter appears ponderous, almost bizarre. It is markedly flattened

at the poles, with slate-blue and pink bands, a wholly alien object compared to Mars. (Fig. 15) Plying its own course in Jupiter's southern latitudes is the Great Red Spot, 30,000 miles long, several times the size of the Earth. The Spot waxes and wanes and changes shape as it rotates about Jupiter's axis faster than the other relatively permanent features of the planet. The Great Red Spot is just the most obvious Jovian enigma. Some additional questions follow:

Some Unsolved Jovian Mysteries

1. Does Jupiter have a solid surface? We see only clouds through the telescope. Jupiter's average density is about equal to 1.3 times that of water.
2. Hydrogen and helium seem to be the major constituents, although helium has not actually been observed, with smaller quantities of ammonia, methane, and other gases. No one knows the percentages accurately.
3. Might not Jupiter be a very primitive planet that will eventually lose most of its lighter elements, revealing beneath a small terrestrial-type core?
4. Why does Jupiter change hues? Are some of these changes synchronized with the 11-year solar cycle as some astronomers assert?
5. What is the nature, strength, and extent of Jupiter's belt of trapped radiation? Some estimates place the strength at one million times that of Earth's belt.
6. Jupiter emits radio signals that seem to be correlated with the motions of its larger satellites. Why?
7. Some of Jupiter's moons are as large as Mercury. Do they have atmospheres and other features of the Earth-like planets?
8. Jupiter possesses a magnetic field many times stronger than Earth's. Earth and Jupiter are so different one wonders whether the fields might have different origins.
9. Jupiter radiates approximately twice as much energy as it receives from the Sun. Where does this energy come from? Is Jupiter, as some think, a very cold, miniature star?

The above list could be extended, but there is no need, Jupiter's alien nature is only too apparent. No wonder it is a prime astronomical target.

Reliability Is the Key. Exploration of the outer solar system differs in one important factor from visiting the other members of our cozy little group of terrestrial planets. That factor is time. The road to Jupiter is a long one—a half billion miles and almost two years long. Furthermore, the propulsive requirements are so high (ten times as much energy per pound of spacecraft as Mariner-Mars 71)

that only a small spacecraft can be economically injected into the long trajectory leading to Jupiter. Therefore, the Jupiter mission should be based on the technology of small, highly reliable spacecraft. NASA has just such a spacecraft family: the Pioneer deep space probes. Four of these craft have been placed in heliocentric orbit. All are still working. Pioneer 6 has been sending telemetry back to Earth since December 1965.

The Jupiter-Pioneer Program has been underway at NASA's Ames Research Center, at Mountain View, California, since 1969. The main target is, of course, Jupiter, but three other objectives help shape spacecraft design and instrument selection:

- Study the interplanetary medium between the Earth and Jupiter.
- Determine the nature of the asteroid belt. Asteroids, by the way, present a hazard to the spacecraft that we cannot evaluate through terrestrial telescopes.
- Develop technology for subsequent flights to the outer planets. In other words, the Jupiter Pioneers are precursors for more ambitious flights to follow.

Using the Mariner-Mars flights to establish a benchmark, the Jupiter-Pioneers must accommodate to two facts of interplanetary life: the communication distance from Jupiter at encounter will be almost three times that at Mars encounter, while the solar power available will be down by a factor of ten. Including the requirements of small size and extremely high reliability, one sees that the Jupiter Pioneers will have to be remarkable machines.

The Jupiter-Pioneers (Pioneers F and G) retain few of the external characteristics of the Pioneers now in heliocentric orbit (Pioneers 6-9). They are, in fact, four times heavier and carry twice as many experiments. Rather than simple, cylindrical spacecraft, like their predecessors, the Jupiter-Pioneers are box-like equipment compartments, each dominated by a 9-foot paraboloidal high-gain antenna and two long booms, each holding two radioisotope thermoelectric generators (RTGs). (Fig. 16) The resemblance to previous Pioneers is primarily internal; that is, electronic. The major features of the Jupiter-Pioneers are summarized in Table 6.

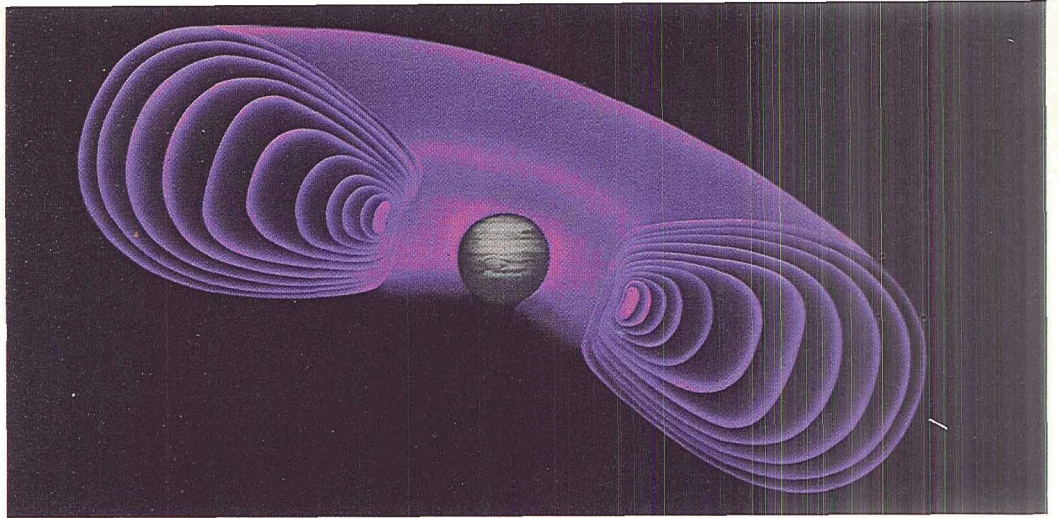

Figure 15. Conceptual view of Jupiter, showing its postulated radiation belts.

TABLE 6. Design Features and Vital Statistics, Jupiter-Pioneers *

Spacecraft Functions	Design Features
Communication and data handling	Redundant travelling wave tubes (for reliability) transmit telemetry to Earth via the 9-foot, S-band, high-gain paraboloid. With 8 watts of power and a 210-foot paraboloid on Earth, a Jupiter-Pioneer can send about 1000 information bits per second from Jupiter at encounter (roughly 440 million miles away). Commands are transmitted "uplink" through the same antennas. Closer to Earth medium/low gain antennas on the spacecraft may be used for communication both ways. When data accumulate faster than they can be transmitted, they are stored in a 49,152-bit memory. The "sequential coding" technique proven on Pioneer 9 will be used.
Power supply	Solar panels were originally proposed, but two pairs of radioisotope thermoelectric generators (RTGs) were substituted later. Mounted away from the spacecraft on two booms, they generate an average of 120 watts. These will be the first NASA spacecraft to depend completely on RTGs. (Fig. 17)
Propulsion	Three hydrazine engines developing about 1 pound of thrust each will produce the impulses necessary for midcourse corrections.
Attitude control	The same hydrazine engines will also partly despin the spacecraft after launch and provide attitude control torques. The spacecraft is spin-stabilized—like a rifle bullet—at about 5 rpm. The high-gain paraboloid always points toward Earth along the spacecraft spin axis, which is fixed in space. The orientation of the spacecraft will be determined by a Sun sensor and a star tracker set on Canopus.
Thermal control	Louvers on the spacecraft bottom maintain internal temperatures between -20° and 90° F.
Structure	Irregular box made of aluminum honeycomb sandwich. Appendages mounted as shown in Fig. 16.
Launch vehicle	The Atlas-Centaur.
Tracking and data acquisition network	The Deep Space Network, with 85-foot and 210-foot paraboloids for tracking, data acquisition, and sending commands from Earth-based controllers.

*Some of these data, particularly weights, may change slightly as design and fabrication proceed.

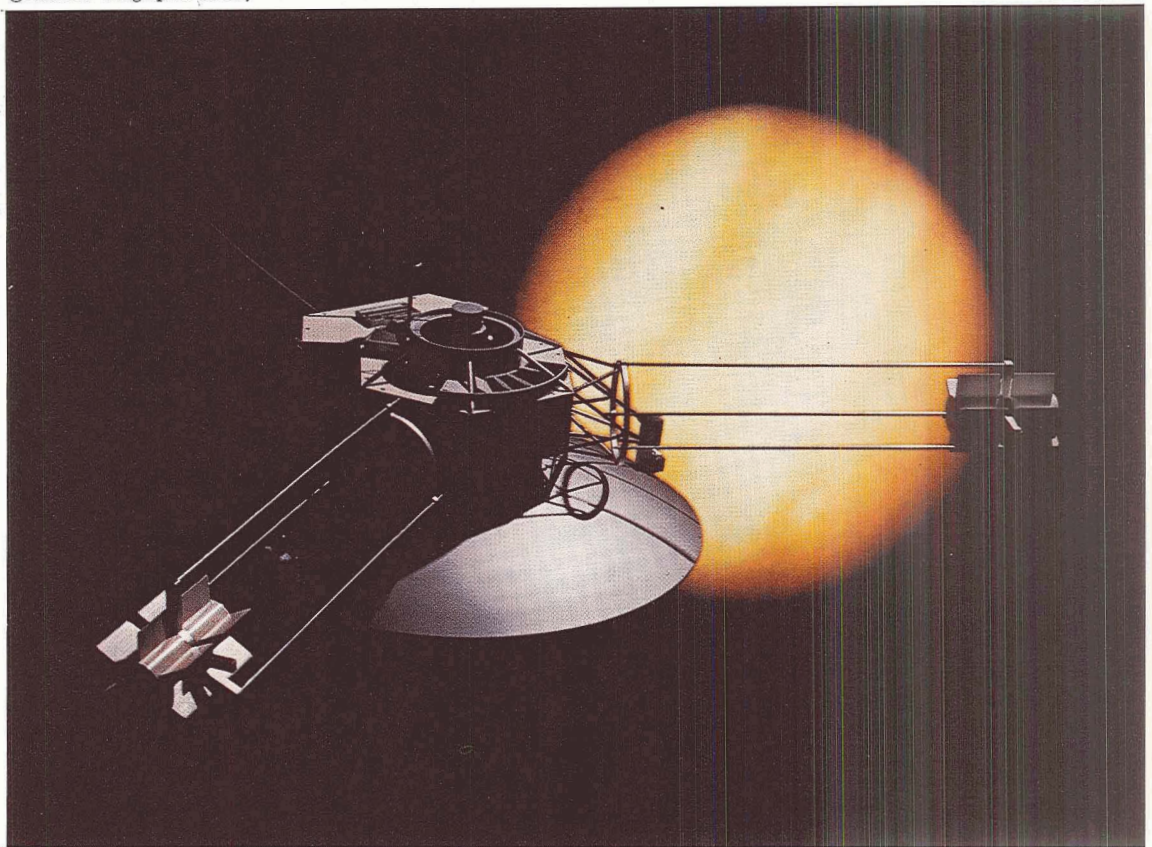
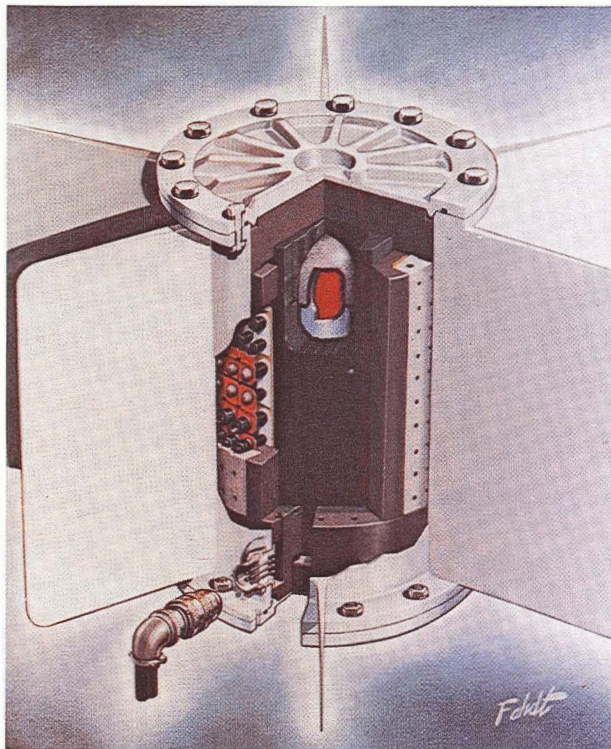

Figure 16. The Jupiter Pioneer spacecraft. (Pioneers F and G).



Pioneer's Diverse Sensors. Thirteen experiments have been selected for the Jupiter-Pioneers. (Table 7) Because the scientific mission includes studies of the interplanetary medium and the asteroid belt on the way to Jupiter, the instrument payload is varied indeed. Roughly half of the experiments will make measurements of space phenomena in transit. Even if the spacecraft should miss Jupiter by a wide margin, the flight could still be highly significant scientifically.

The Longest Interplanetary Flight. Jupiter's period of rotation around the Sun is so long (nearly 12 years) that the Earth catches up to it and passes once every 13 months. As a consequence, Jupiter launch opportunities occur every 13 months. The launch windows selected for the Jupiter-Pioneers are:

- Pioneer F Feb. 26 to March 26, 1972
- Pioneer G March 30 to May 1, 1973.

Figure 17. Cutaway view of the RTG to be used on Pioneers F and G. Heat from the central capsule of plutonium-238 is partially converted into electricity by the small cylinders of thermoelectric material.

TABLE 7. Scientific Instrumentation, Jupiter Pioneers

Experiment/Instrument	Scientific Objectives	Principal Investigators
Magnetic fields: tri-axial helium magnetometer	Measurement of the interplanetary and Jovian magnetic fields	E. J. Smith (Jet Propulsion Laboratory)
Plasma: 2 quadraspherical plasma analyzers	Measurement of the interplanetary solar wind and the boundaries of the Jovian magnetosphere	J. H. Wolfe (Ames Research Center)
Charged particles: solid-state telescope, high-energy electron and proton detectors	Measurement of interplanetary solar-generated protons, electrons, and helium nuclei. Measurement of Jovian trapped radiation.	J. A. Simpson (University of Chicago)
Jovian charged particles: Geiger telescope, triangular array of detectors, and low-energy Geiger.	Measurement of the energies and species of charged particles trapped by Jupiter's magnetic field.	J. A. Van Allen (University of Iowa)
Cosmic rays: 3 radiation telescopes	Measurement of the energies and distributions of galactic and solar protons, electrons, and light nuclei through neon.	F. B. McDonald (Goddard Space Flight Center)
Jovian trapped radiation: Cerenkov counter, electron scatter detector, scintillator, and other detectors.	Measurement of the energies and species of charged particles trapped by Jupiter's magnetic field.	R. W. Fillius (University of California, San Diego)
Ultraviolet photometry: single-channel ultraviolet photometer	Mapping of ultraviolet "heliosphere." Determination of Jupiter hydrogen-helium ratio, presence of auroras, and atmosphere scale height.	D. L. Judge (University of Southern California)
Imaging photopolarimeter: a small scanning telescope with a Jupiter resolution of 120 miles.	Mapping of zodiacal light. Study of asteroids and Jovian satellites. Imaging of Jupiter in two colors.	T. Gehrels (University of Arizona)
Infrared thermal structure: 2-channel radiometer	Measurement of the net thermal energy flux emitted by Jupiter.	G. Munch (California Institute of Technology)
Asteroid-meteoroid astronomy: 3 Ritchey-Cretein telescopes	Measurements of the distribution of particles and cometary matter.	R. K. Soberman (General Electric Co.)
Meteoroid detection: 216 pressurized cells	Measurement of meteoroid population and spacecraft hazards within asteroid belt.	W. H. Kinard (Langley Research Center, NASA)
S-Band occultation: uses spacecraft transmitter signals	Measurement of effect of solar corona on radio waves and the refractivity of Jovian ionosphere and atmosphere.	A. J. Kliore (Jet Propulsion Laboratory)
Celestial mechanics: uses spacecraft tracking data	More accurate determination of Jupiter's mass and ephemeris and the motion of its satellites.	J. D. Anderson (Jet Propulsion Laboratory)

The widths of these windows may decrease if the mission profile is changed to improve the instruments' view of Jupiter. Launches will be from Cape Kennedy using the Atlas-Centaur vehicles with an added upper stage motor. After a few minutes in parking orbit around the Earth, the upper stage and Centaur will inject the spacecraft into the Jupiter transfer ellipse. When the upper stage cuts off, the spacecraft velocity relative to the Earth will be about 32,400 mph, the highest velocity ever given to a spacecraft.

Between 150 and 350 days after launch, the spacecraft's trajectory will take it through the asteroid belt. (Fig. 18) The trip time to Jupiter may be as low as 640 days or as long as

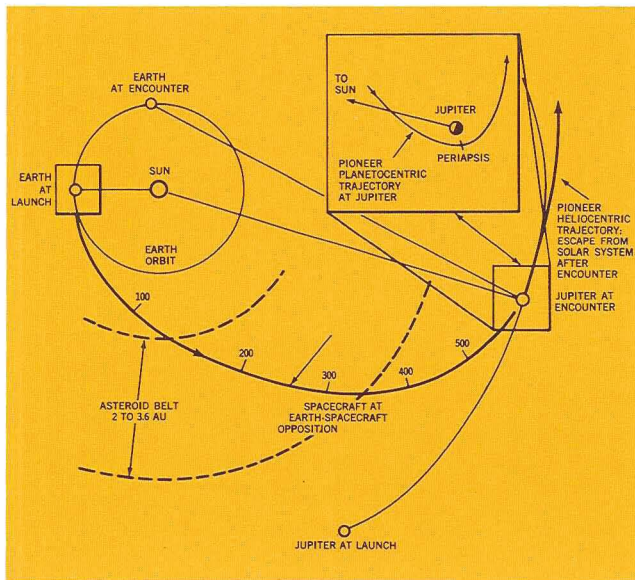

Figure 18. The Jupiter trajectory to be flown by Pioneers F and G.

748 days, depending on when the spacecraft is launched during the launch window. The trajectory currently planned will take the Pioneer to about three planetary radii from Jupiter's center (about 100,000 miles from the surface). During the flyby, pictures of the planet will be taken; the radiation belts, magnetic field, cloud structure, and other Jovian phenomena will be measured, as detailed in Table 7. (Fig. 19)

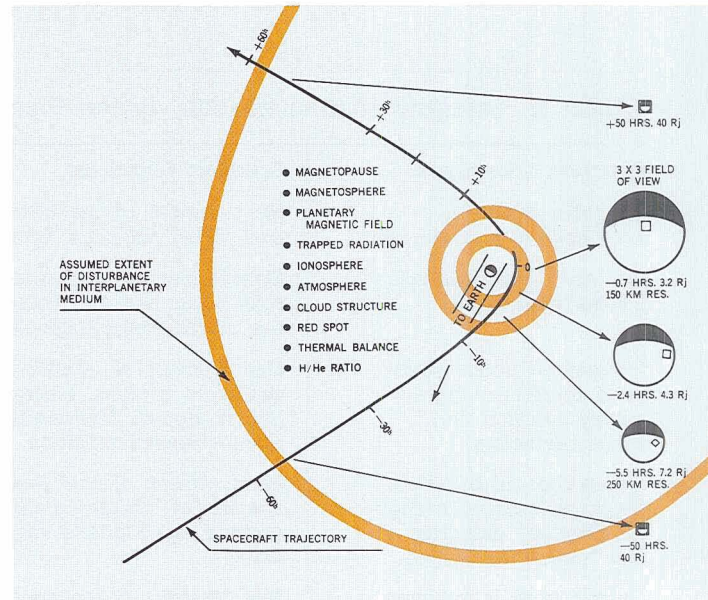

Figure 19. Details of the Pioneer encounters with Jupiter, showing the relative sizes of the planet and resolutions of imaging equipment at various times.

The gravitational field of Jupiter will deflect (really "fling") the spacecraft outward so that it will eventually escape the solar system completely to become the first interstellar probe. Hopefully, the spacecraft will continue to function long after the encounter with Jupiter so that we may learn what transpires in interplanetary space beyond Jupiter. If the Jupiter Pioneers prove to have the longevity of their heliocentric ancestors, we may receive telemetry data from the limit of our 1972-73 communication capability—possibly 1.4 billion miles from Earth, out into Saturn's realm.

OUTER PLANETS MISSION

Once every 175 years, the four giant planets are aligned in such a way that a single spacecraft launched from Earth has a sporting chance of flying by all of them; Jupiter, Saturn, Uranus, and Neptune. This would be the so-called Grand Tour Mission. The trip from Earth to Neptune flyby would begin in the 1977-1978 period and last until roughly 1986—a flight time of over eight years. The mission would require spacecraft considerably more reliable than those being built for the Jupiter mission. In addition, mission success would depend heavily on accurate guidance because first Jupiter and then Saturn must assist the spacecraft with their gravitational fields. The communication distance from Neptune to Earth would be more than 2.5 billion miles, illustrating once again the vastness of the outer solar system compared to our tightly knit inner, terrestrial planets.

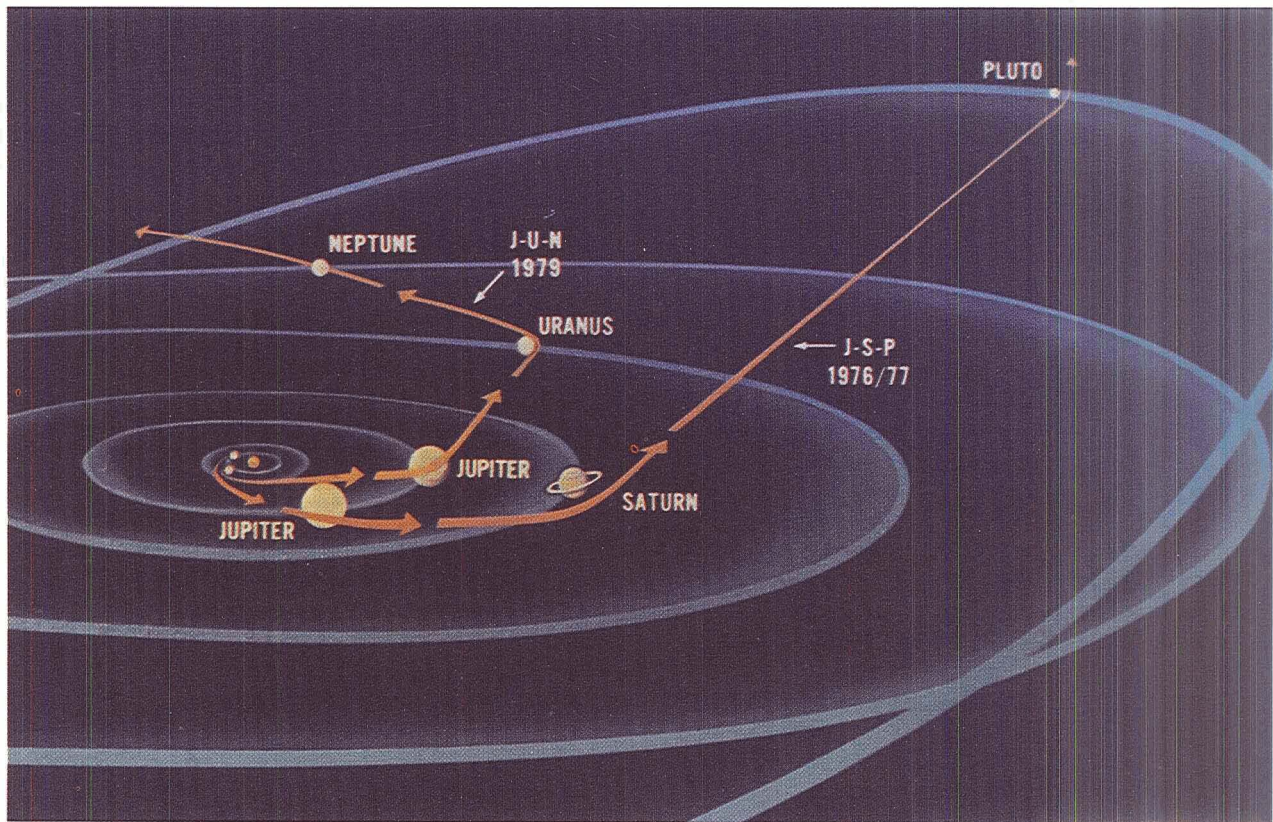

Figure 20. The two proposed three-planet tours of the outer planets.

While the opportunity for the four-planet mission is a very rare event, three-planet and two-planet Mini-Tours could be flown more frequently. (Fig. 20) One of the more interesting of these is the Jupiter-Saturn tour, which is possible every 20 years. Jupiter and Uranus can be probed by spacecraft every 14 years.

Despite the rarity of a four-planet opportunity, NASA currently favors taking advantage of two three planet opportunities with single Jupiter-Saturn-Pluto launches in 1976 and 1977 and dual Jupiter-Uranus-Neptune launches in 1979. The resultant flyby data from all of the outer planets would be returned in time for knowledgeable planning of second-generation missions and the establishment of relative priorities among the outer planets before the next two-planet opportunities occur in the 1990s.

Many types and sizes of spacecraft have been evaluated for accomplishing the exploration of the outer solar system. The Thermoelectric Outer Planets Spacecraft (TOPS) concept of the Jet Propulsion Laboratory for a basic multi-purpose spacecraft has been selected as the most economical approach consistent with the highest priority scientific objectives and the long-life reliability required for all outer-planets missions. A stabilized scan platform, such as that used on the Mariners will permit sensitive measurements to be made on the planets and satellites. TOPS will also take advantage of recent high frequency communications developments to achieve high real-time data rates from Jupiter and scientifically useful data rates over even the three-billion mile distances to Neptune and Pluto. The TOPS concept also incorporates adaptive control and self-test

and repair features believed essential to achieving long-life reliability with a high degree of confidence. (Fig. 21)

A 150-watt radioisotope thermoelectric generator (RTG) is being developed by the Atomic Energy Commission to provide a steady source of power independent of the spacecraft's distance from the Sun.

The self-test and repair (STAR) computer, already well along in development, is capable of managing and controlling all spacecraft functions independent of any commands from Earth. The necessity for this capability becomes apparent if one realizes that when the outer-planets spacecraft approaches Neptune and Pluto, a radio signal traveling at the speed of light will take eight hours to make the round trip from Earth. Results to date in the development of the STAR computer and of its highly miniaturized electronic micro-circuits already promise an unprecedented advance in operating reliability. This highly compact and competent STAR computer, weighing only 30 pounds and "guaranteed" to last at least ten years without servicing, is expected to see widespread application, not only in many future

spacecraft and throughout the aerospace industry, but also in general commercial applications. STAR is a step toward truly automatic spacecraft that will "think for themselves."

AN INNER TOUR MARINER-MERCURY/VENUS 73

Mars and the solar system giants pose perplexing scientific problems, but Venus and Mercury are hardly devoid of mystery. Let us look, then, toward the Sun, where distances are shorter but where searing solar rays replace the deep freeze of the outer solar system.

Venus has already seen five space probes: Mariners 2 and 5 plus three in Russia's Venera series. Nevertheless, the major questions raised about Venus remain unsolved; in fact, there seems to be more controversy than ever. In particular, we know little of what lies below the thick, opaque Venusian atmosphere that except for tantalizing glimpses of "something" below the clouds, hides the planet's visible surface. Special radars based on Earth have penetrated the cloud blanket with long-wavelength pulses of radio energy. The echoes returned to Earth reveal surface relief, perhaps

Figure 21. TOPS is the Thermoelectric Outer Planets Spacecraft, a concept for a basic multi-purpose spacecraft for exploration of the outer planets. © National Geographic Society

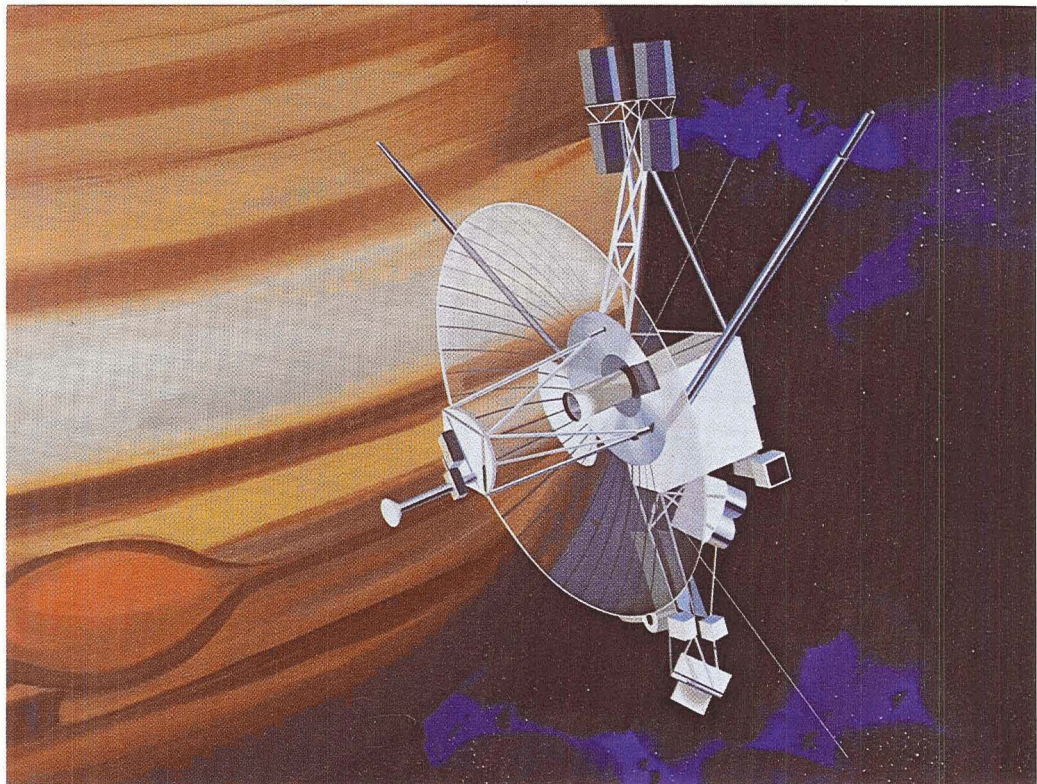

mountainous areas. What is more, the planet's direction of rotation is very slow and opposite that of the other terrestrial planets. Some of the most intriguing questions about Venus are listed below:

Some Unsolved Venusian Mysteries

1. What does the surface look like? Orbiting probes will have to draw maps by radar because the surface receives little or no sunlight.
2. Past probes show the Venusian atmosphere to be over 90% carbon dioxide with only 0.1 to 0.7% water vapor. If Venus is so dry what makes up the clouds? Doubtless, they are totally unlike terrestrial clouds.
3. The Soviet probe, Venera 4, abruptly ceased transmitting before scheduled touchdown on the planet's surface. Was it crushed by the high pressures, which are estimated to be 100 times those on the Earth's surface? Our model of the Venusian atmosphere depends heavily upon data from Veneras 4, 5, and 6 and Mariner 5; but many questions raised by these flights remain unanswered.
4. The magnetic field of Venus is apparently less than 0.1% that of the Earth's field. This was surprising initially because Venus has long been characterized as Earth's "twin." Now, it is thought that Venus' small field is a natural consequence of its slow rate of rotation. More magnetic field measurements are needed to study this problem.

Mercury is always located close to the Sun; astronomers have despaired of ever seeing much detail on the planet's surface. There are vague markings to be sure, but this planet confounds the best observers. For example, until recently, the classical figure for Mercury's period of rotation was 88 days. The planet was supposed to be chained gravitationally to the Sun so that it always kept the same side pointed toward the Sun—just as the Moon does to the Earth. Radar observations from Earth followed by some new visual measurements indicate that Mercury turns on its axis once every 59 days. This figure is exactly $\frac{2}{3}$ of one of Mercury's years, leading some astronomers to suspect some sort of resonance action between Mercury and the Sun. Just why any resonance should exist, no one knows. Mercury also presents us with other puzzles.

Some Unsolved Mercury Mysteries

1. What does it look like? Is it cratered like the Moon, Mars, and the Earth?
2. The average density of Mercury is significantly higher than that of the Earth. Did Mercury have a different origin or have its lighter elements been volatilized by the Sun—perhaps a much hotter Sun?
3. Often Mercury's already indistinct features are suddenly veiled. Is there an atmosphere that somehow survives despite the Sun's heat? Are there dust storms on Mercury?

Another Member of the Mariner Family. The 1973 mission to Venus and Mercury, is a late addition to NASA's program of planetary exploration. For this reason, the description that follows does not have the detail of the other approved NASA missions, and is more subject to rethinking.

The Venus-Mercury Mariner will strongly resemble the Mariners that flew past Mars in 1969. This similarity is to be expected because the missions are similar and, because of the short lead time involved, NASA had to make heavy use of the well-proven Mariner technology. The novel aspect of the Venus-Mercury mission is that it is a double flyby. There is also the problem of solar heating, but the Mariners sent to Venus in 1962 and 1967 also had to solve this problem. The Mariner design summarized in Table 2 can be used as a reference providing the following changes are made:

- Only two solar panels are required to capture enough power from the much nearer Sun. The solar panels will be tiltable to reduce the Sun's heating effects.
- The maneuver engine will be so mounted that the entire spacecraft and its equipment bays can be tilted with respect to the Sun to reduce the heat load.
- Temperature-controlling louvers will be added to more of the equipment bays to help keep their contents cool.

The overall spacecraft will weigh just over 900 pounds. The Atlas-Centaur will launch this Mariner from Cape Kennedy. As usual with planetary missions, the Deep Space Network will track, command, and acquire data from the spacecraft.

NASA solicited the scientific community for Venus-Mercury experiments in March 1970. On July 28, 1970, NASA announced that the seven experiments listed in Table 8 had been selected for flight. All of the instruments have been proven in previous space flights.

The "outer tour" described earlier is a rare phenomenon because favorable arrangements of all four giant planets repeat only after long intervals. Mercury and Venus, however, rotate around the Sun much more quickly—as described by Isaac Newton. Opportunities for "inner" Tours to these planets thus arrive much more frequently. The 1973 opportunity requires a launch from Cape Kennedy between October 12, 1973, and November 20, 1973. The spacecraft is first placed in a parking orbit around the Earth by the Atlas-Centaur launch vehicle. When the proper moment arrives, the Centaur upper stage injects the spacecraft into the heliocentric orbit shown in Fig. 22.

The heliocentric orbit will, after midcourse corrections, possess just the right eccentricity for the spacecraft to intercept Venus between Feb. 3 and Feb. 6, 1974. The distance of closest approach should be 2500–3000 miles. The gravitational pull of Venus will deflect the spacecraft into a new orbit that will lead to the Mercury encounter between March 19 and April 3, 1974. Using additional midcourse maneuvers, the trajectory should come within 700 miles of the surface. At the time of the Mercury flyby, the Earth will be between 80 and 100 million miles away. Following this encounter, the Mariner will orbit the Sun with a period of about 176 days.

CLOSEST TO THE SUN HELIOS 74, 75

The Sun is the mainspring of the solar system. It dominates many planetary phenomena and is thus a factor in our exploration of the planets. NASA is building no solar probes of its own, but it is supporting the West German Helios Program. The spacecraft is being designed and built by a group of German firms headed by Messerschmitt-Bölkow-Blohm GmbH. The General Electric Co., in the United States, is a consultant on the project. NASA will supply the launch vehicle, a pad and facilities at Cape Kennedy, and the services of the Deep Space Network.

The objective of Helios is the measurement of the structure and time variation of the plasma, cosmic rays, and magnetic fields in interplanetary space as they are controlled by solar processes and events. This objective is essentially the same as that of America's heliocentric probes, Pioneers 6–9. Pioneers 6–9, however, ranged only between 0.8 and 1.2 A.U.*, while the two Helios probes will penetrate to 0.3 A.U.

Helios will utilize many of the design features of Pioneers 6–9. It will be a cylindrical spacecraft,

*A.U. = astronomical unit. 1 A.U. is equal to the average distance between the Sun and the Earth, about 93 million miles.

Figure 22. The Mariner-Mercury/Venus mission calls for an "inner tour" past the planets between the Earth and the Sun.

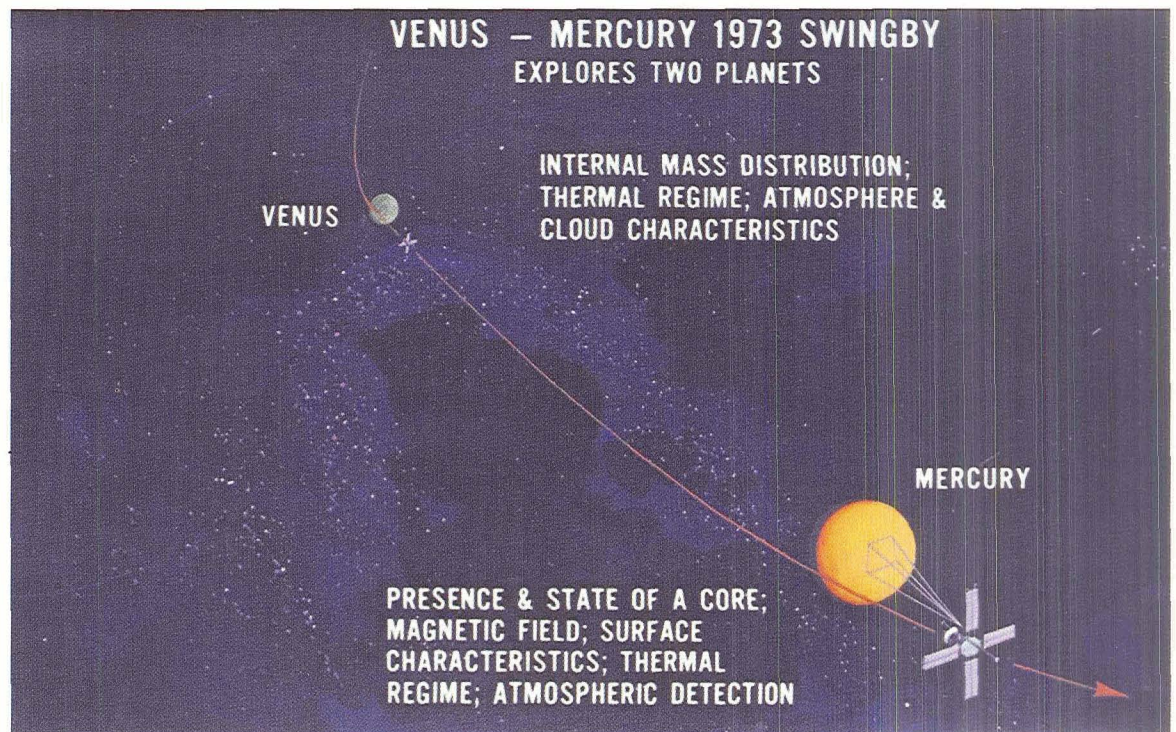

TABLE 8. Scientific Instrumentation, MARINER-VENUS/MERCURY 73

Instrument	Scientific Objectives	Scientific Team Leader
Two television cameras with 1500-mm telescopes	Study Venus' dense cloud blanket and the ultraviolet clouds that appear to circle the planet. Map and identify Mercury's landmarks, such as craters; determine spin axis orientation. Search for satellites of both planets.	B. C. Murray (California Institute of Technology)
Spacecraft transmitter and terrestrial receivers	Provide radio propagation data on interplanetary phenomena during flight and, at planetary encounters, information on atmospheres, ionospheres, radii, and surface characteristics.	H. T. Howard (Stanford University)
Scanning Electron Analyzer (SEA)	Determine how solar wind interacts with Venus and Mercury and the characteristics of the solar wind between Earth and Mercury. Compare latter data with similar data from Pioneers F and G between Earth and Jupiter.	H. S. Bridge (M.I.T.)
Two triaxial fluxgate magnetometers	Measure the interplanetary magnetic field and the fields near Venus and Mercury. Study the interaction of the solar wind with these planets.	N. F. Ness (Goddard Space Flight Center)
Two ultraviolet grating spectrometers	Search for an atmosphere surrounding Mercury and, if it exists, determine its structure and composition. Obtain similar data for the atmosphere of Venus.	A. L. Broadfoot (Kitt Peak National Observatory)
Infrared radiometer	At Venus, measure cloud-top and limb-darkening temperatures and search for holes in the cloud cover. At Mercury, measure surface-brightness temperatures and correlate infrared features with visible features.	S. S. Chase, Jr. (Santa Barbara Research Center)
Charged particle detector	Study the charged particle bombardment of Mercury and the properties of charged particles reaching Mercury from solar flares.	J. A. Simpson (University of Chicago)

with a narrow waist and flared ends. (Fig. 23) Four radial booms will protrude from the waist; on top, another boom and the antenna lie along the spin axis. The spacecraft will be spin-stabilized in space so that its spin axis is always perpendicular to the plane of the ecliptic. So far, the description given resembles that of Pioneers 6-9. Helios, though, will weigh about 425 pounds, more than twice as much as the early Pioneers.

Two problems faced by Helios require drastic departures from Pioneer design philosophy.

First, the solar heat necessitates a new thermal protection strategy for the sensitive solar cells. The

Figure 23. The West German Helios solar probe. Solar cells and mirrors cover the flared sides. The antenna reflector on top of the spacecraft is spun mechanically so that it always points at the Earth.

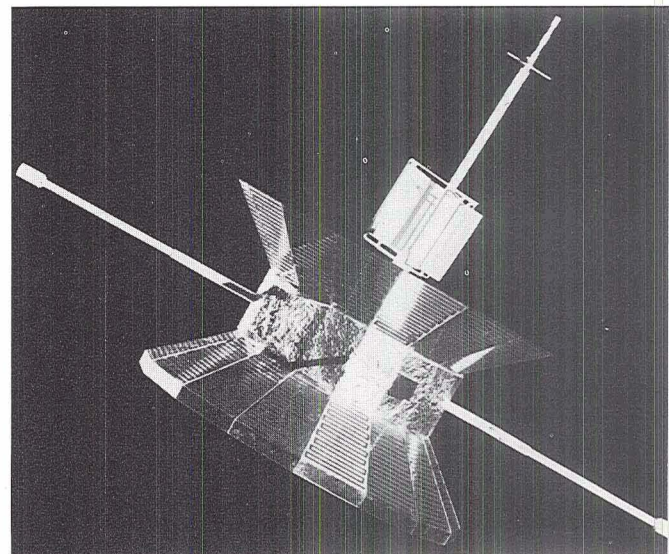

TABLE 9. Helios Scientific Experiments

Instrument	Scientific Objectives
Plasma analyzer	Measurement of the solar wind velocity
Fluxgate magnetometers (2 separate experiments)	Measurement of the interplanetary magnetic field close to the Sun
Search-coil magnetometer	Measurement of low frequency fluctuations in the interplanetary field
Plasma and radio-wave experiment	Measurement of radio waves from 50 kHz to 2 MHz; measurement of plasma from 10 Hz to 100 kHz
Cosmic-ray detector	Measurement of the energies of solar and galactic cosmic rays
Cosmic-ray detector	Measurement of the flux and energies of solar and galactic cosmic rays; measurement of solar X-rays
Electron detector	Counting of solar electrons
Zodiacal light photometer	Observation of zodiacal light wavelength and polarization
Micrometeoroid analyzer	Measurement of the masses and energies of cosmic dust particles

solar-cell surfaces are slanted (Fig. 23) so that the sunlight does not hit them directly. In addition, the solar cells are interspersed checkerboard fashion with mirrors having the same dimensions as the cells. Heat from the solar cells is conducted to adjacent metal-backed mirrors and radiated away.

The second problem involves the much greater communication distances. To be able to reach the Earth with its telemetry, Helios' transmitter power must be concentrated in a narrow beam. To this end, a parabolic reflector is mounted behind the antenna on top of the spacecraft. However, the Helios spacecraft, being spin-stabilized, rotates continuously. The reflector, therefore, must be spun in the opposite direction so that it points perpetually at the Earth. This is called a "mechanically despun" antenna, and Helios is the first interplanetary probe to use one.

The ten experiments scheduled for flight on Helios are listed in Table 9.

Two Helios spacecraft are being built. The planned launch dates are in July 1974 and

October 1975. (Note that one does not have to wait for just the right arrangement of planets to launch solar probes.) From Cape Kennedy, Helios will be injected into a heliocentric orbit having a perihelion of 0.3 A.U. and an aphelion of 1.0 A.U. Since the orbital period will be roughly 200 days, the closest approaches to the Sun will occur 100, 300, 500, etc. days following the launch.

IN THE DECADE OF THE 1970s

If only one planet—the Earth—circled the Sun, and it had no Moon, space travel would be an impractical dream. Lonely in the light years of emptiness, we would have no convenient intermediate astronomical targets to land upon. But, in reality, we have stepping stones to the edge of the solar system. And these planets are so different from the Earth that our innate curiosity insists that we explore them. What are our sister planets like? Do they harbor life? In the preceding pages the Mariners, Vikings, and Pioneers of the immediate future have been described. Their destinations are known; but they are only the precursors.

**ADDITIONAL
READING**

For titles of books and teaching aids related to the subjects discussed in this booklet, see NASA's educational publication EP-48, Aerospace Bibliography, Fifth Edition.

Produced by the Office of Public Affairs
National Aeronautics and Space Administration

☆ U.S. GOVERNMENT PRINTING OFFICE: 1971 O-440-917

For sale by the Superintendent of Documents, U.S. Government Printing Office, Washington, D.C. 20402 - Price 75 cents
Stock Number 3300-0399

EP-82

PLANETARY EXPLORATION

Space
In
The
Seventies

National Aeronautics and Space Administration