

FINITE ELEMENT ANALYSIS USING NASTRAN APPLIED TO HELICOPTER TRANSMISSION VIBRATION/NOISE REDUCTION*

R. W. Howells and J. J. Sciarra
Boeing Vertol Company

SUMMARY

A finite element NASTRAN model of the complete forward rotor transmission housing for the Boeing Vertol CH-47 helicopter has been developed and applied to reduce transmission vibration/noise at its source. In addition to a description of the model, a technique for vibration/noise prediction and reduction is outlined. Also included are the dynamic response, as predicted by NASTRAN, test data, the use of strain energy methods to optimize the housing for minimum vibration/noise, and determination of design modifications which will be manufactured and tested. The techniques presented are not restricted to helicopters but are applicable to any power transmission system. The transmission housing model developed can be used further to evaluate static and dynamic stresses, thermal distortions, deflections and load paths, fail-safety/vulnerability, and composite materials.

INTRODUCTION

Considerable attention has been focused in recent years on the reduction of noise levels for both military and civil helicopters. Helicopter noise emanates from three major sources - the rotor blades, engines, and transmissions. Exterior noise is dominated by the rotors and engines, although the transmissions also contribute to this noise. Minimization of the exterior noise is important to reduce the annoyance to communities near civil helicopter operations and to reduce the detectable noise signature of military helicopters. The interior cabin noise is predominantly due to the transmissions (Figure 1), with the engines and rotors being secondary sources. Interior noise not only degrades crew performance by causing annoyance and fatigue, but interferes with reliable communication and may cause hearing damage. Comfortable interior noise levels are essential for passenger acceptance of civil helicopters.

By any of the numerous standards in existence for scaling annoyance and reactions to noise (Reference 1), transmission noise is particularly objectionable. Noise in excess of 120 db has been

* This work has been performed under U. S. Army contract AAJ02-74-C-0040, U. S. Army Air Mobility Research and Development Laboratory, Eustis Directorate, Fort Eustis, Virginia.

measured for the transmission of a medium transport helicopter (References 2 and 3) which, for comparison, approaches the noise level of an air raid siren. Not only is this noise level high, but its frequency typically falls within the sensitive 1000-5000 Hz range which is particularly annoying to the human ear (Figure 2). Furthermore, the pure tonal content, which results in a high-pitched whine, is subjectively much more annoying than broad-band noise (Figure 3).

Transmission noise and the inherent structural vibrations which generate this noise have been of concern to helicopter designers for many years. Until recently, analytical methods have not been available to predict and reduce transmission vibration/noise problems in advance. The conventional means of controlling transmission noise has generally been to add acoustical enclosures after the hardware is built and a noise problem has become evident. Since practical enclosures are limited in noise attenuation by unavoidable sound leaks in seams and access doors, adequate attenuation is not provided for advanced helicopter drive systems of increased power (References 2 and 3). Not only do these enclosures impose considerable weight and maintainability penalties, but they do not reduce the deleterious effect of the accompanying vibrations which contribute to material fatigue and fretting at joints.

A significant program in the area of transmission vibration/noise reduction is in progress at Boeing Vertol. The objective of this work is to generate analytical tools that will provide the capability to perform trade studies during the design stage of a program. This capability will yield optimized drive train components that are dynamically quiet with inherently longer life and reduced vibration and attendant noise levels.

MECHANISM OF TRANSMISSION NOISE GENERATION

The transfer of torque between mating gears is not uniform due to tooth profile errors and the elastic deformation of the gear teeth under load (References 2 and 3). This non-uniform transfer of torque produces a dynamic force at the gear mesh frequency (number of teeth x rpm) and its multiples which excites the coupled torsional/lateral vibratory modes of the gear shaft. This lateral vibration (or bending) produces displacements at the bearing locations which excite the housing and cause it to vibrate, thus radiating noise (Figure 4). Furthermore, the dynamic characteristics of the housing may magnify its displacements and the resulting noise.

NOISE REDUCTION

A three-pronged analysis for the reduction of vibration/noise at its source has been developed which includes the reduction of dynamic excitation, the reduction of dynamic response, and the use of auxiliary devices for vibration absorption. Controlling the dynamic response of the transmission is a desirable approach to noise reduction since avoidance of resonance reduces shaft deflections at the bearings which inherently increases the life of dynamic components and transmission reliability. The finite element modeling of the transmission housing using NASTRAN is an integral part of this analytical technique.

Detuning of Internal Components

Reduction of the dynamic excitation of the housing is accomplished by minimizing the dynamic forces at the shaft support bearings. This is a two-fold task. First, the excitation due to the dynamic tooth forces is calculated from the gear geometry and operating conditions. Second, the damped force response of the shafts responding to the tooth mesh excitation loads is calculated from a finite element model and the shaft is detuned using strain energy methods to minimize the displacement at the bearings. The development of this method, accomplishment of extensive dynamic testing, and correlation of data are described fully in References 2 and 3. Finally, the dynamic forces associated with the optimum configuration of the internal components are then applied to excite the model of the housing. To study the response of the transmission housing to these forces and to minimize the noise produced, a finite element model of the housing was developed and analyzed using NASTRAN.

Application of NASTRAN to Finite Element Model of Housing

The Boeing Vertol CH-47 forward rotor transmission housing is composed of three major sections: upper cover, ring gear, and case (Figure 5). The upper cover provides lugs for mounting the transmission to the airframe and transmits the rotor system loads. The case contains and supports the main bevel gears. The ring gear, which connects the upper cover and case, contains the planetary gear system. This natural division of the housing was adhered to for ease of modeling (Figure 5).

The geometric grid points for the model were defined from design drawings and by cross-checking on an actual housing. CQUAD2 (Quadrilateral) and CTRIA2 (Triangular) homogeneous

plate (membrane and bending) elements were used to connect the grid points and build the NASTRAN structural model. A Boeing Vertol preprocessor program (SAIL II - Structural Analyses Input Language) for the automatic generation of grid point coordinates and structural element connections was used. This preprocessor allows the user to take advantage of any pattern which occurs in the data by providing straight-forward techniques for describing algorithms to generate blocks of data. The extensive computer generated plotting capability of NASTRAN was used to de-bug the structural model.

For ease of identification the housing was subdivided into several regions and the grid points in each region were labeled with a specific, but arbitrary, series of numbers. Although these grid point numbers act only as labels, they affect the bandwidth of the stiffness and mass matrices. In order to minimize the matrix bandwidth for most efficient running of NASTRAN, the BANDIT computer program (Reference 4) was used to automatically renumber and assign internal sequence numbers to the grid points. The output from BANDIT is a set of SEQGP cards which are then included in the NASTRAN bulk data deck and which relate the original external grid numbers to the internal numbers.

The model includes grid points representative of the structure where the shafts are supported by their bearings as well as grid points representative of the planet-ring gear tooth meshes. These grid points are used to apply the dynamic excitations at the mesh frequencies to analytically excite the housing. Although each geometric grid point has six possible degrees of freedom (3 translational and 3 rotational), the displacements normal to the outer surface of the housing are of most interest for noise evaluation since it is this out-of-plane motion which generates sound waves (Figure 6). To conveniently evaluate the motion normal to the housing surface, numerous local coordinate systems were defined and oriented such that the displacements and accelerations calculated at each grid point could be referred to a coordinate system having an axis normal to the housing surface. One degree of freedom, rotation about the normal to the surface, was constrained since the stiffness for this component is undefined for NASTRAN plate elements. The other two rotational degrees of freedom were omitted. All translational degrees of freedom were retained to accurately represent the motion of the actual housing. Because of the large model size, the Guyan reduction technique was used to reduce the size of the analysis set. The Givens method of eigenvalue extraction was used and the model parameters are summarized in Figure 7.

Detuning of Housing Response (Strain Energy)

Each natural mode of a structure contributes to vibration in proportion to its amplification factor, which is the ratio of exciting frequency to natural frequency. Consequently, since each mode whose frequency is in the vicinity of a forcing frequency will be a major contributor to the overall dynamic response, it is desirable to alter the housing natural frequencies so that none fall close to an exciting frequency.

Strain energy techniques for structural optimization have evolved in recent years. For applications such as helicopters where weight is critical, it is more appropriate to evaluate the strain density (strain energy/volume) distribution within a structure which provides guidance for vibration reduction by identifying the structural elements participating in the modes (Reference 5). To optimize a housing for minimum vibration/noise, the NASTRAN normal modes analysis is used to obtain a dynamic solution; by employing the ALTER feature of NASTRAN, a checkpoint tape containing the stresses for each element is generated. The natural frequencies calculated are compared with the gear mesh exciting frequencies to identify each mode shape whose natural frequency is close to an exciting frequency and which it is desirable to shift. A post-processor program has been developed which uses the data stored on the checkpoint tape to calculate the strain density of NASTRAN plate elements and tabulate the elements in order of descending strain density. The structural elements with the highest strain density are the best candidates for effective modification of the natural frequency since a minimal weight change will yield a maximum shift in natural frequency (Reference 6). By locally altering the housing wall to change the mass and stiffness in these areas of high strain density, the natural frequency may be shifted away from an exciting frequency (Figure 8). Thus, the possibility of resonance is eliminated and the vibration and radiated noise are reduced. This strain density distribution concept can also be utilized statically to identify structural load paths and evaluate the efficiency of the housing structural design (stiffness/weight).

RESULTS

A complex gearbox such as a helicopter rotor transmission typically has more than one gear mesh, hence more than one exciting frequency. For instance, the Boeing Vertol CH-47C helicopter forward rotor transmission employs a spiral bevel gear mesh plus a two-stage planetary gear system. Additional

sources of exciting frequencies in the form of sidebands are introduced by planetary gear configurations (Reference 7) and manufacturing variations (Reference 8). This occurrence of multiple exciting frequencies, coupled with the fact that the housing possesses many natural frequencies, makes it a complex task to detune the housing so that none of the exciting frequencies coincides with a natural frequency. The primary frequencies for the CH-47 forward rotor transmission have been identified experimentally as the bevel gear mesh frequency and the lower planetary gear mesh frequency (LP1) and its second (LP2) and third (LP3) harmonics.

The experimental program described in References 2 and 3 included the dynamic testing of a CH-47C forward transmission with internal instrumentation to measure strains, displacements, and accelerations of the rotating components and external instrumentation to measure housing acceleration and noise. Correlation of this data with the analysis has indicated that by modifying the gear/shaft/bearing system geometry the internal components may be detuned to minimize excitation of the housing. Application of strain density techniques to these dynamic components has identified modifications which have analytically reduced the loads exciting the housing at the bevel mesh, LP2 and LP3 frequencies. Loads at the LP1 frequency increased. Since the effect of multiple noise sources are added logarithmically, the reduction of three out of four noise sources may not appreciably reduce the overall noise level.

Noise measurements have tended to confirm that housing responses exist and generate noise. This is evidenced, for example, by the LP2 and LP3 frequencies. Although the exciting source for these frequencies is within the ring gear, the maximum noise at these frequencies emanates from the mid-case region (Figure 9).

Some of the calculated natural frequencies of the housing and the main exciting frequencies are plotted on the spectrum shown in Figure 10. A NASTRAN plot of the housing 46th mode, which has a natural frequency closest to the LP2 exciting frequency, is shown in Figure 11. It is important to note that since the exciting frequencies will vary with changes in operating speed, the housing must be detuned at a specific operating speed. The use of strain density has led to preliminary identification of the areas (see shaded elements Figure 12) of the housing structure which will be modified to detune the housing for reduced vibration/noise. The strain density distribution was determined using the NASTRAN post-processor for the modes with frequencies nearest to the four main exciting frequencies and the elements with high strain density were identified. For each mode considered the elements with high strain density are generally different; however, some elements are common to two or more of the modes. Strictly speaking, the

elements with highest strain density for each mode should be modified to achieve the maximum frequency shift for each corresponding mode. This approach would be used during the design of a new housing. To modify an existing housing, however, it would be cumbersome to incorporate the numerous and varied modifications indicated by such a rigorous application of the analysis. Therefore, for practical application to the experimental housing herein, those elements with a relatively high strain density which are common to two or more modes have been identified (Figure 12) and will be used to shift the housing frequencies. In this manner a specified structural change will alter two or more frequencies, although perhaps no single frequency will be shifted maximally. It is more feasible to modify these elements since the actual changes to the existing housing design for testing will be limited to a few easily accessible areas on the exterior walls of the housing. This approach should provide sufficient detuning to demonstrate the validity of the analysis. Prior to finalizing the detuned design, the dynamic response of the model, with the structural modification incorporated, will be re-calculated using NASTRAN. Comparison with the baseline housing response will determine whether to proceed with the manufacture of the test hardware or to further evaluate the detuning procedure.

A test program described in Reference 9 was conducted to evaluate the effect of dynamic absorbers on transmission noise. The results indicated that internal dynamic absorbers provided some noise reduction, but the reduction was not sufficient to warrant practical application. External dynamic absorbers applied to the housing have been evaluated using NASTRAN rigid format 11. By applying absorbers on the housing at the points of load application (i.e. bearing supports) the excitation of the housing has been reduced. However, the absorbers are effective only for a very narrow range of frequencies. For a transmission housing with several excitation frequencies, absorbers may be useful to reduce a particularly troublesome frequency. As a general transmission noise reduction method, the use of absorbers must be further evaluated.

CONCLUDING REMARKS

The basic analytical approach as a design tool for transmission vibration/noise reduction has been partially validated. The method unites the internal components and the housing, and hence will optimize the transmission as a complete operating system. Since the housing provides structural support to the internal components, its physical characteristics grossly affect performance and life in terms of internal bearing

capacity, gear capacity, fretting, misalignments, etc. Therefore, housing optimization is essential if the full benefit of the advancements in gear and bearing technology are to be realized.

With the existing housing model, further investigations utilizing NASTRAN are planned to evaluate static and dynamic stress, thermal distortions, deflections and load paths due to any type loading, fail-safety, vulnerability, and composite materials (Figures 13 and 14).

REFERENCES

1. Munch, C., A STUDY OF NOISE GUIDELINES FOR COMMUNITY ACCEPTANCE OF CIVIL HELICOPTER OPERATIONS, Journal of the American Helicopter Society, January 1975, Pages 11-19.
2. Hartman, R., A DYNAMICS APPROACH TO HELICOPTER TRANSMISSION NOISE REDUCTION AND IMPROVED RELIABILITY, Paper Presented at the 29th Annual National Forum of the American Helicopter Society, Washington, D. C., May 1973, Preprint No. 772.
3. Hartman, R., and Badgley, R., MODEL 301 HLH/ATC TRANSMISSION NOISE REDUCTION PROGRAM, USAAMRDL TR 74-58, May 1974.
4. Everstine, G., BANDIT - A COMPUTER PROGRAM TO RENUMBER NASTRAN GRID POINTS FOR REDUCED BANDWIDTH, Naval Ship Research and Development Center Technical Note AML-6-70, February 1970.
5. Sciarra, J. J., VIBRATION REDUCTION BY USING BOTH THE FINITE ELEMENT STRAIN ENERGY DISTRIBUTION AND MOBILITY TECHNIQUES, 45th Shock and Vibration Symposium, Dayton, Ohio, August 1974.

6. Sciarra, J., USE OF THE FINITE ELEMENT DAMPED FORCED RESPONSE STRAIN ENERGY DISTRIBUTION FOR VIBRATION REDUCTION, U. S. Army Research Office - Durham, Final Report Contract DAH-C04-71-C-0048, July 1974.
7. Gu, A., Badgley, R., and Chiang, T., PLANET-PASS-INDUCED VIBRATION IN PLANETARY REDUCTION GEARS, ASME Paper 74-DET-93, Presented at the Design Engineering Technical Conference, New York, New York, October 5-9, 1974.
8. Gu, A., and Badgely, R., PREDICTION OF VIBRATION SIDEBANDS IN GEAR MESHES, ASME Paper 74-DET-95, Presented at the Design Engineering Technical Conference, New York, New York, October 5-9, 1974.
9. Sternfeld, H., Schairer, J., and Spencer, R., AN INVESTIGATION OF HELICOPTER TRANSMISSION NOISE REDUCTION BY VIBRATION ABSORBERS AND DAMPING, USAAMRDL TR 72-34, August 1972.

TWIN ENGINE RATING - 4474 kW AT 245 RPM
(6000 HP)
SINGLE ENGINE RATING - 2796 kW
(3750 HP)
GROSS WEIGHT - 20866 kg
(46,000 LB)

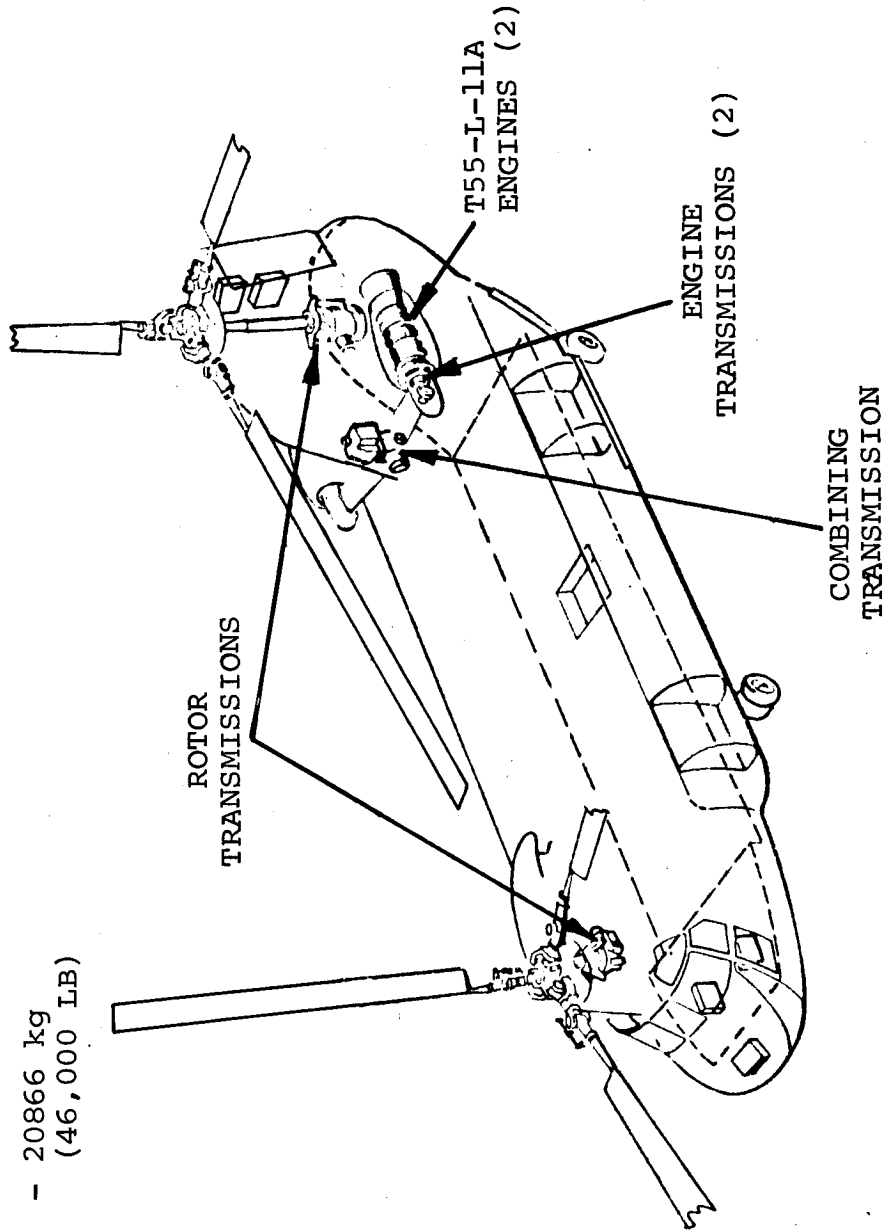

Figure 1. Boeing Vertol CH-47 Helicopter.

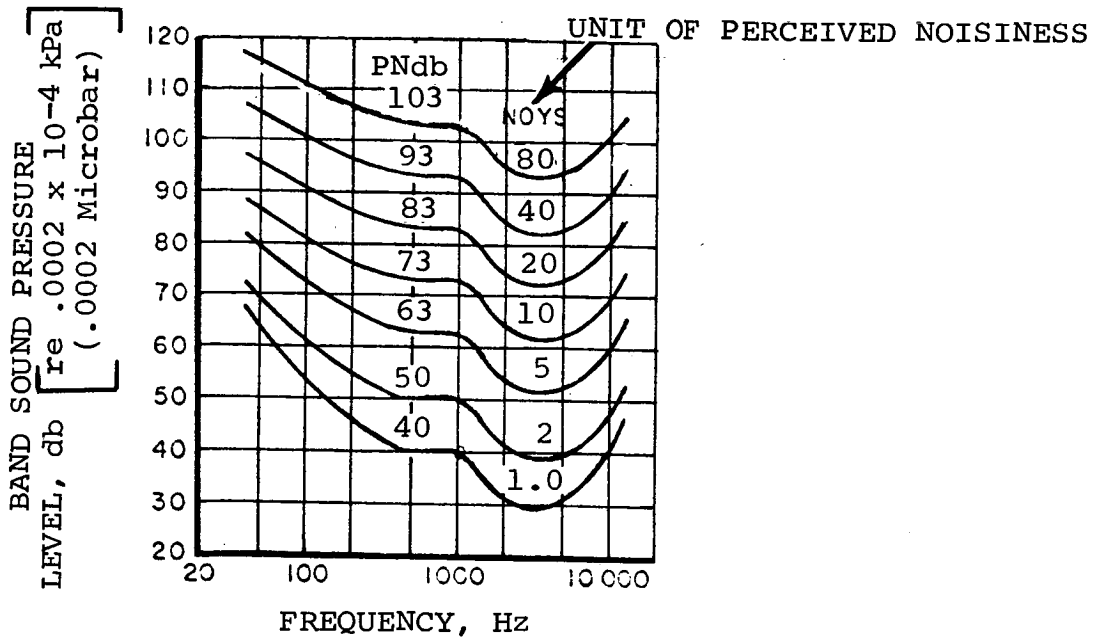

Figure 2. Perceived Noisiness of Bands of Sound.

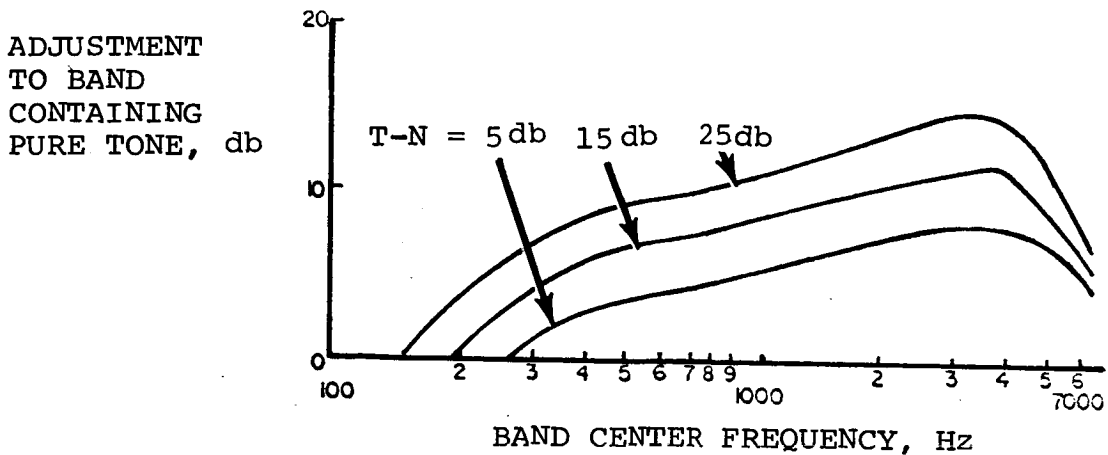

Figure 3. Tone Corrections - Adjustment to be Added to Broad Band Noise Level (N) When Pure Tone (T) is Present.

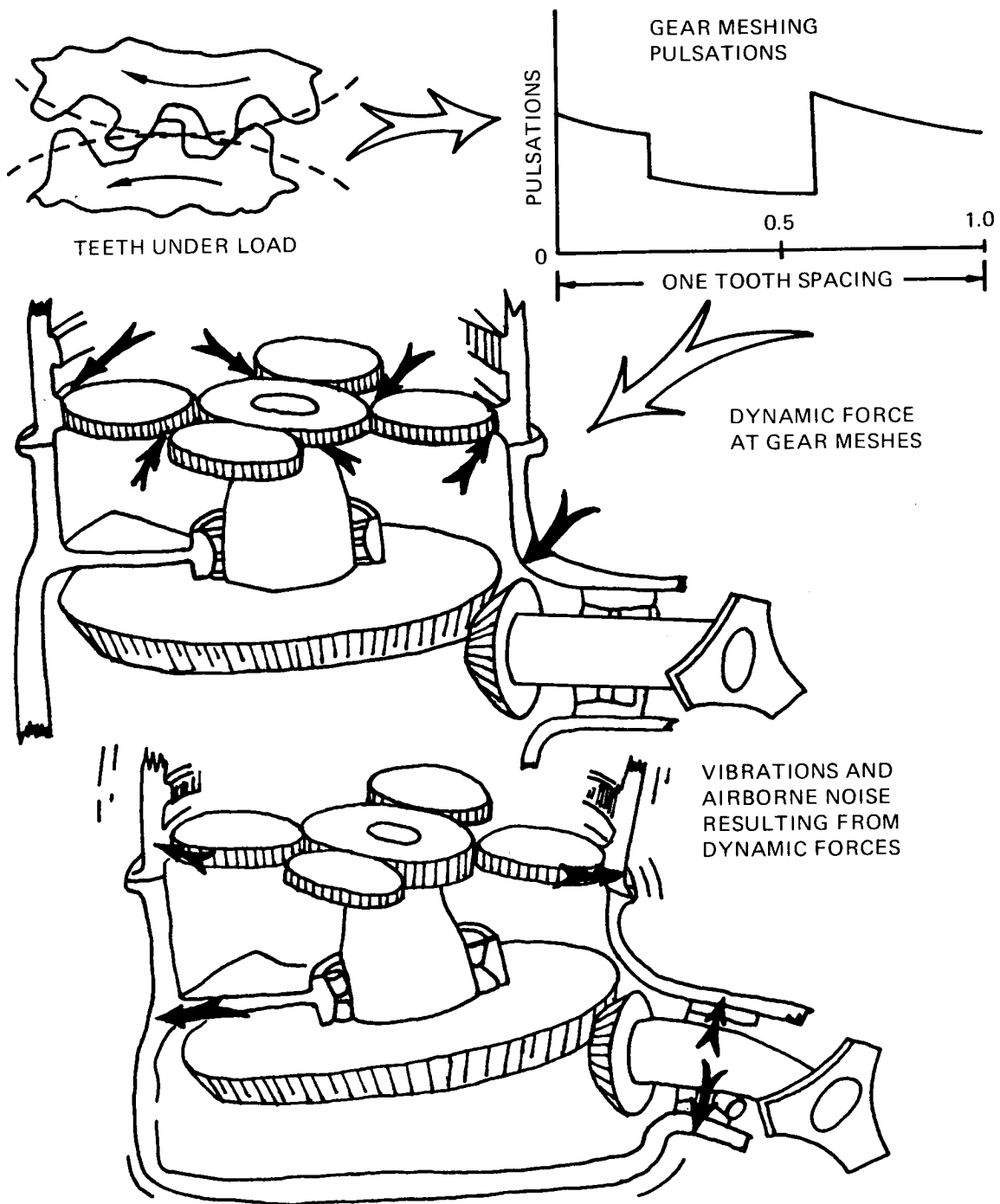

Figure 4. Sources of Transmission Noise.

CH-47

FORWARD TRANSMISSION

TRANSMISSION HOUSING MODEL

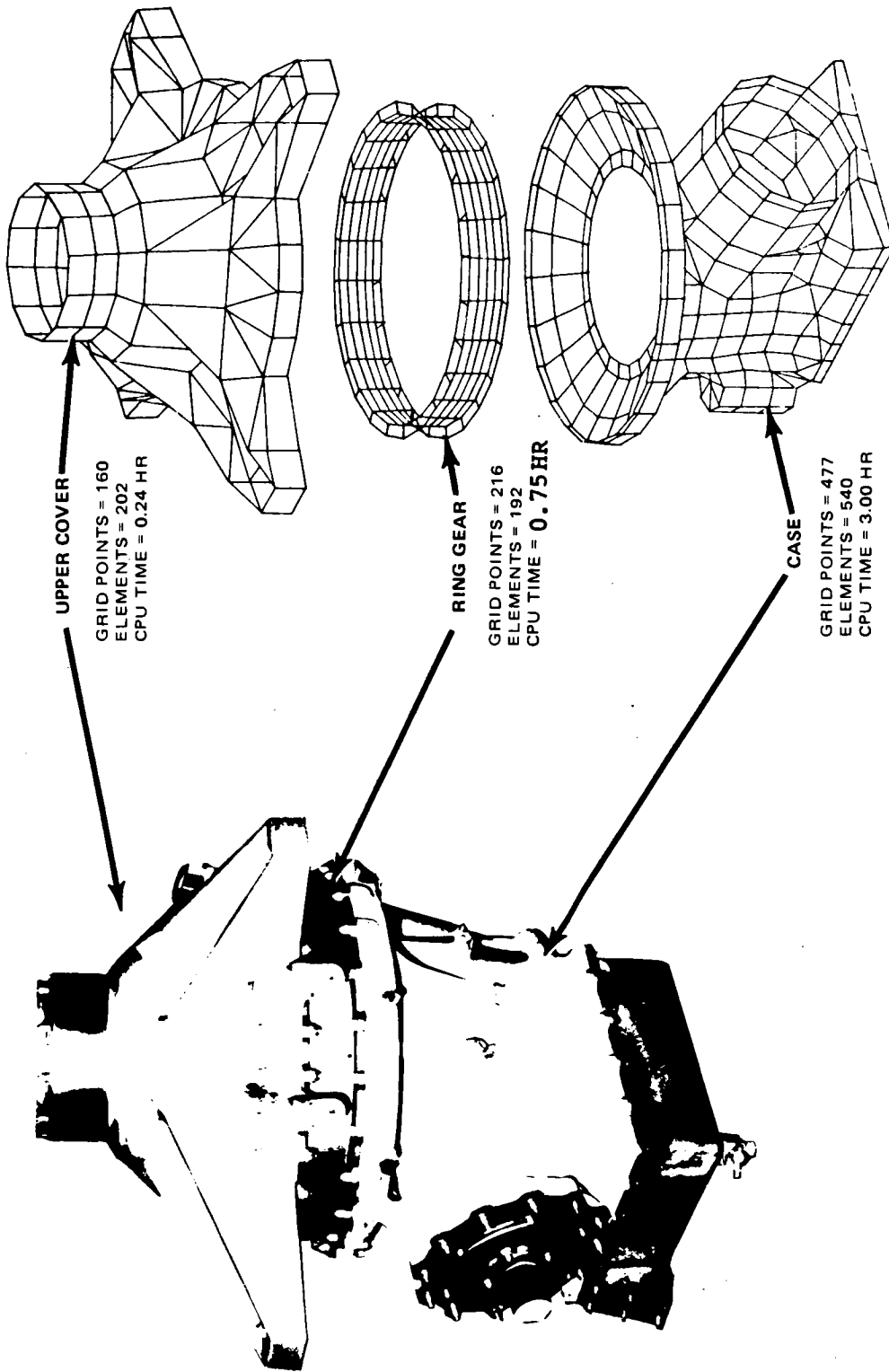

Figure 5. Boeing Vertol CH-47 Helicopter Forward Rotor Transmission Housing and NASTRAN Model.

DISPLACEMENTS

T₁ = Out-Of-Plane

T₂ = In-Plane

T₃

ROTATIONS

R₁ = Fixed

R₂ = Unrestrained

R₃

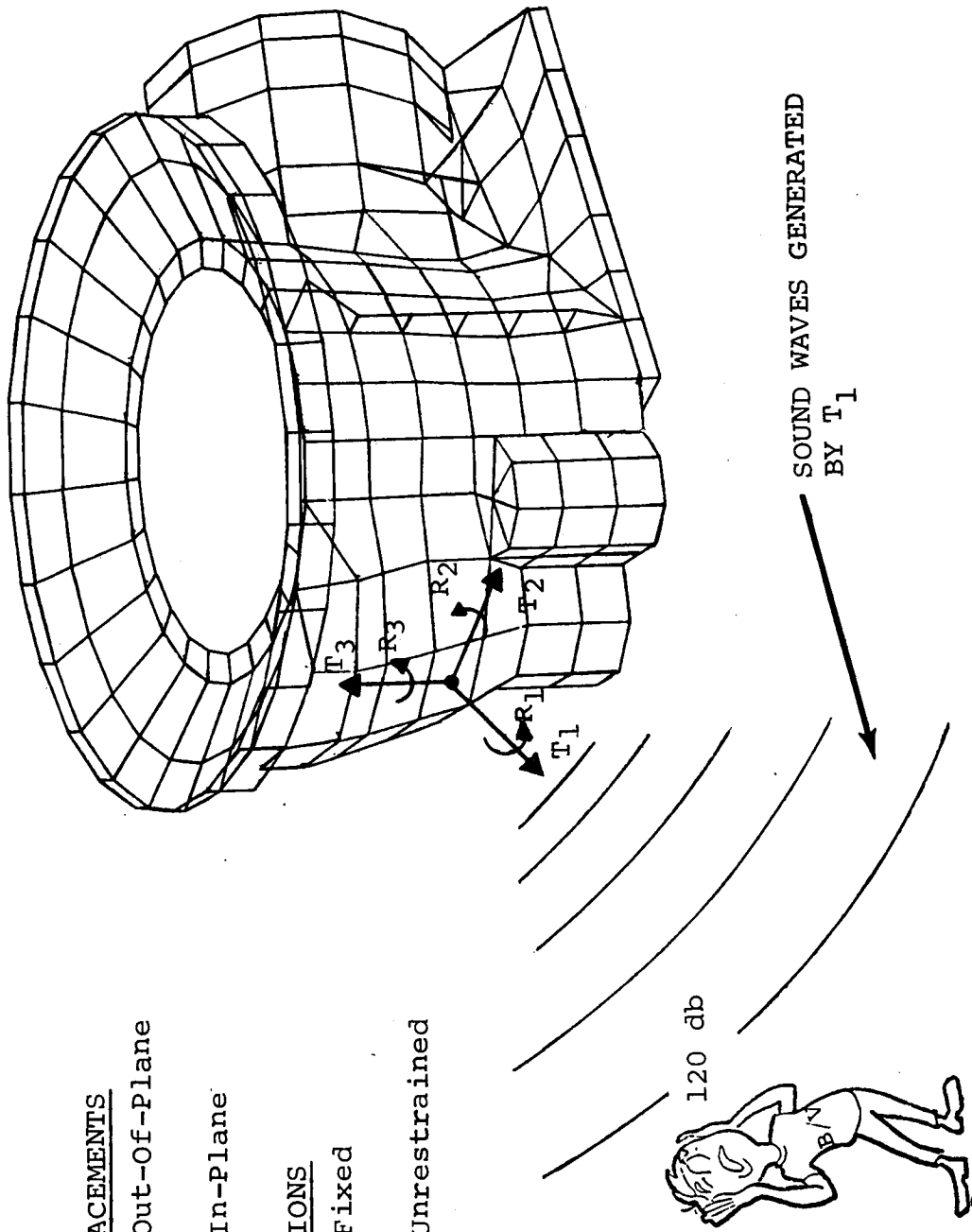

Figure 6. Transmission Noise Generated by Out-Of-Plane Displacements of Housing.

MODEL PARAMETERS

	NUMBER	NUMBER	NUMBER	BANDWIDTH	CPU TIME (HOURS) *				
	GRID POINTS ELEMENTS	DEGREES OF FREEDOM	ACTIVE						
	TOTAL	SPC OMIT	RETAINED	FULL REDUCED	COLUMNS				
Upper Cover	160	202	960	184	614	162	34	0	0.24
Ring Gear	216	192	1296	216	828	252	-	0	0.75
Case	477	540	2862	529	2024	309	61	0	3.00
TOTAL	853	934							

*RIGID FORMAT 3

COMPARISON OF CALCULATED AND ACTUAL WEIGHTS

	MODEL	HARDWARE	DIFFERENCE
Case	25.1 kg (55.4 lb)	24.6 kg (54.2 lb)	+ 2.2%
Ring Gear	28.6 kg (63.0 lb)	34.9 kg (77.0 lb)	-18.1% (No Teeth)
Upper Cover	62.8 kg (138.5 lb)	64.1 kg (141.4 lb)	- 2.0%

Figure 7. Summary of CH-47 Forward Transmission Housing NASTRAN Model.

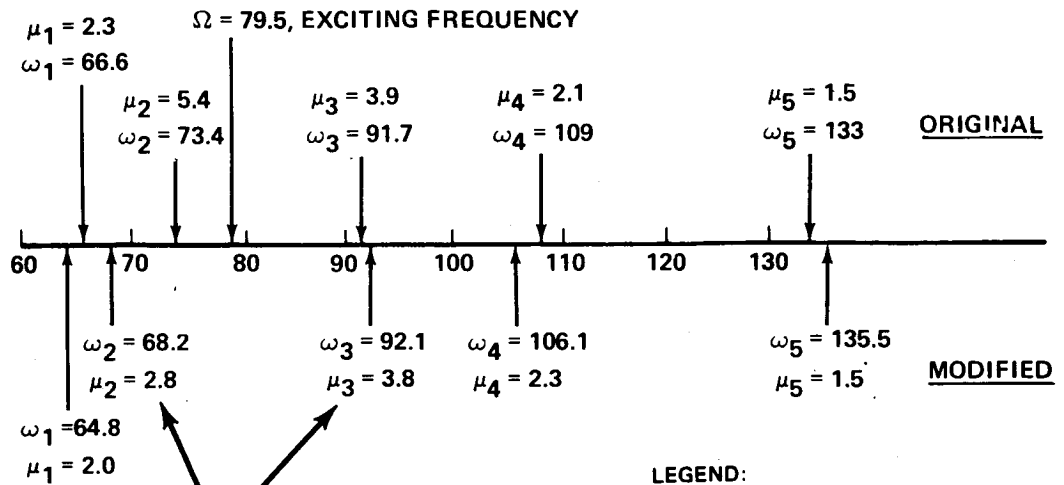

Natural Frequencies Moved Away From Exciting Frequency and Amplification Factors Reduced

Figure 8. Example of Optimization of Natural Frequency Spectrum, CH-47 Helicopter Fuselage Forward Pylon Structure.

MICROPHONE INSTALLATION

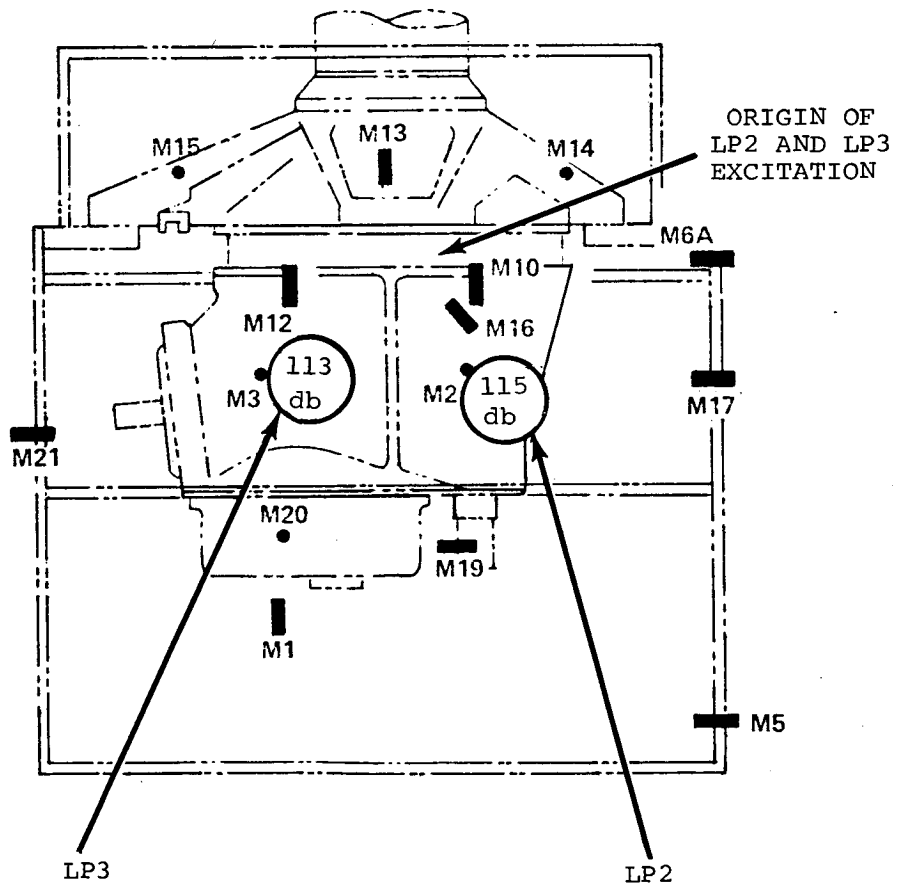

Figure 9. Maximum Measured Noise Levels (7460 RPM at 80% Torque).

FORCING FREQUENCIES (AT 243 ROTOR RPM)

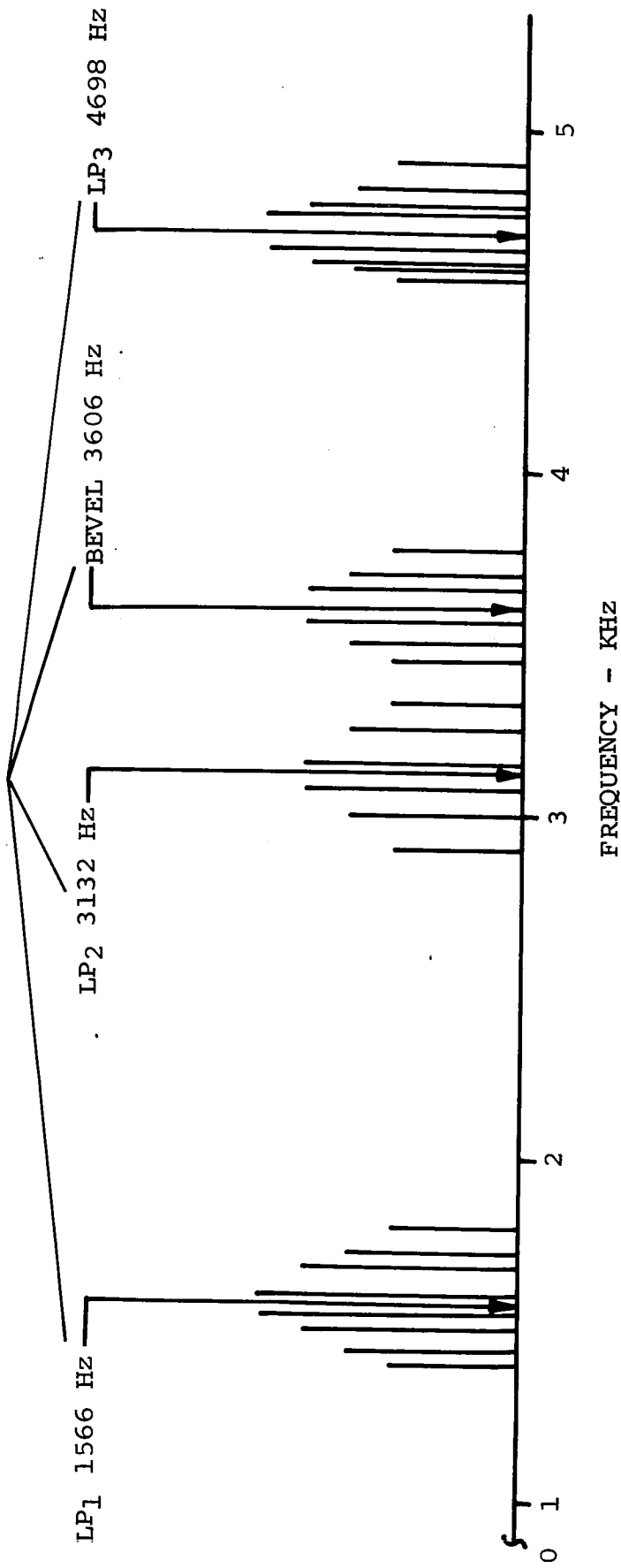

Figure 10. Spectrum of Forcing Frequencies Versus NASTRAN Predicted Natural Frequencies for CH-47C Forward Transmission Case.

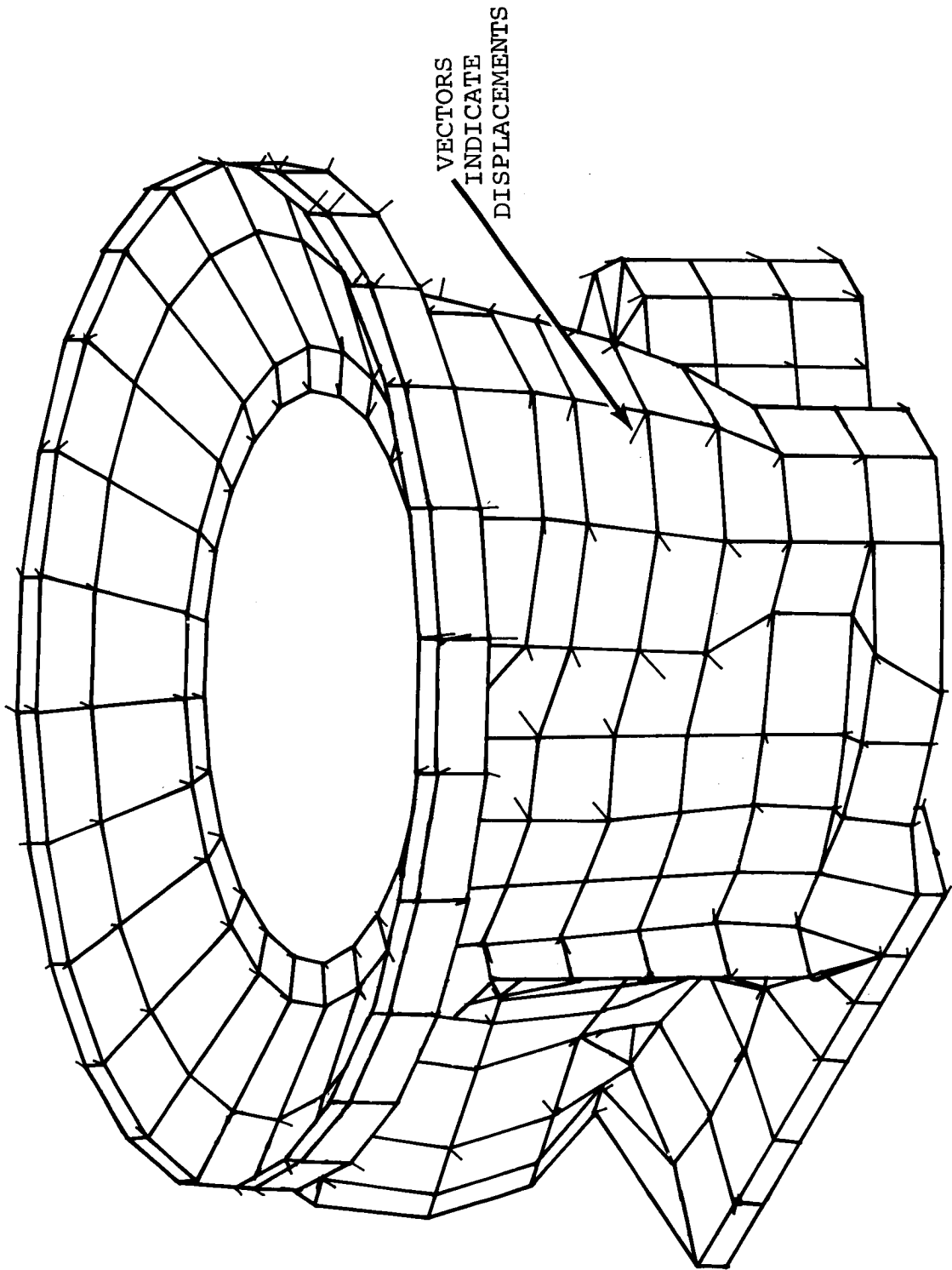
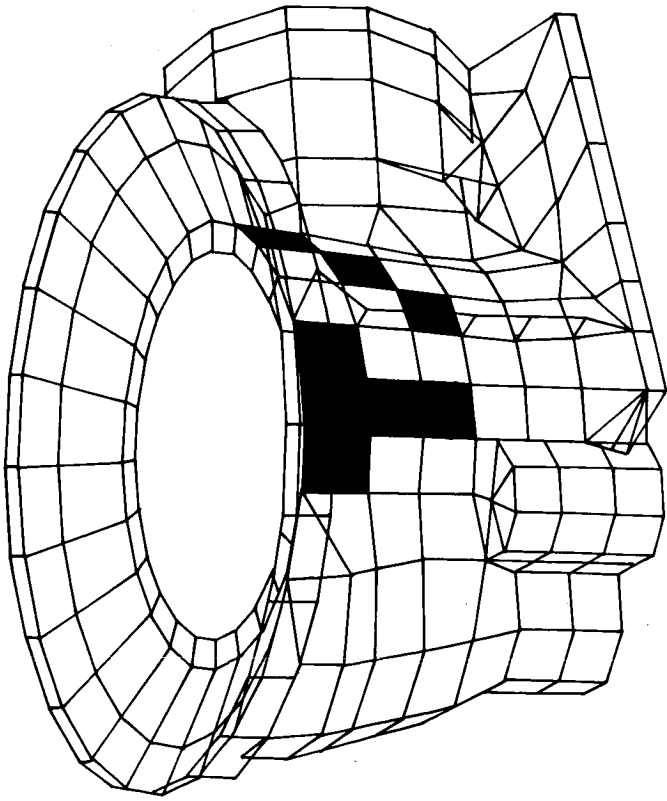
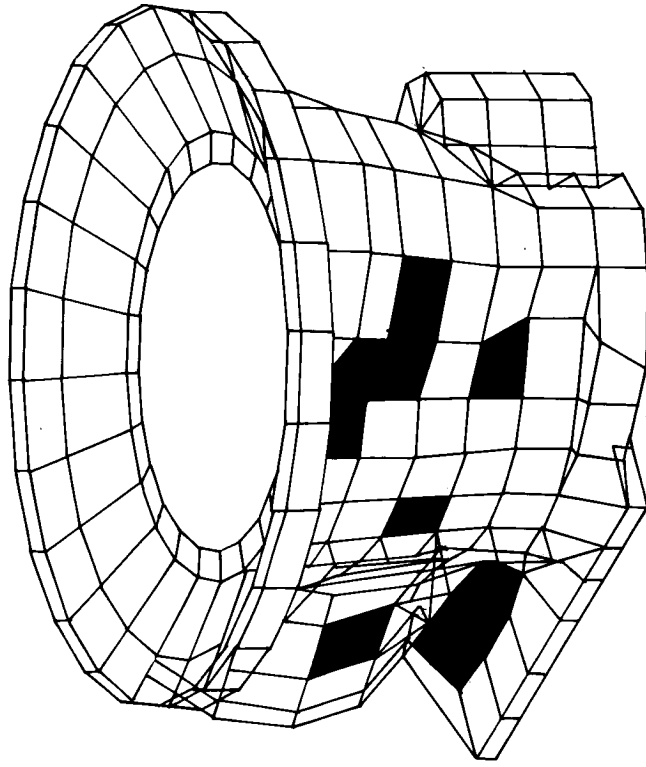

Figure 11. NASTRAN Plot of Deformed Housing,
Mode #46, Frequency 3141 Hz.



LEFT SIDE VIEW



FRONT VIEW

Figure 12. CH-47 Forward Transmission NASTRAN Model Areas of High Strain Density.

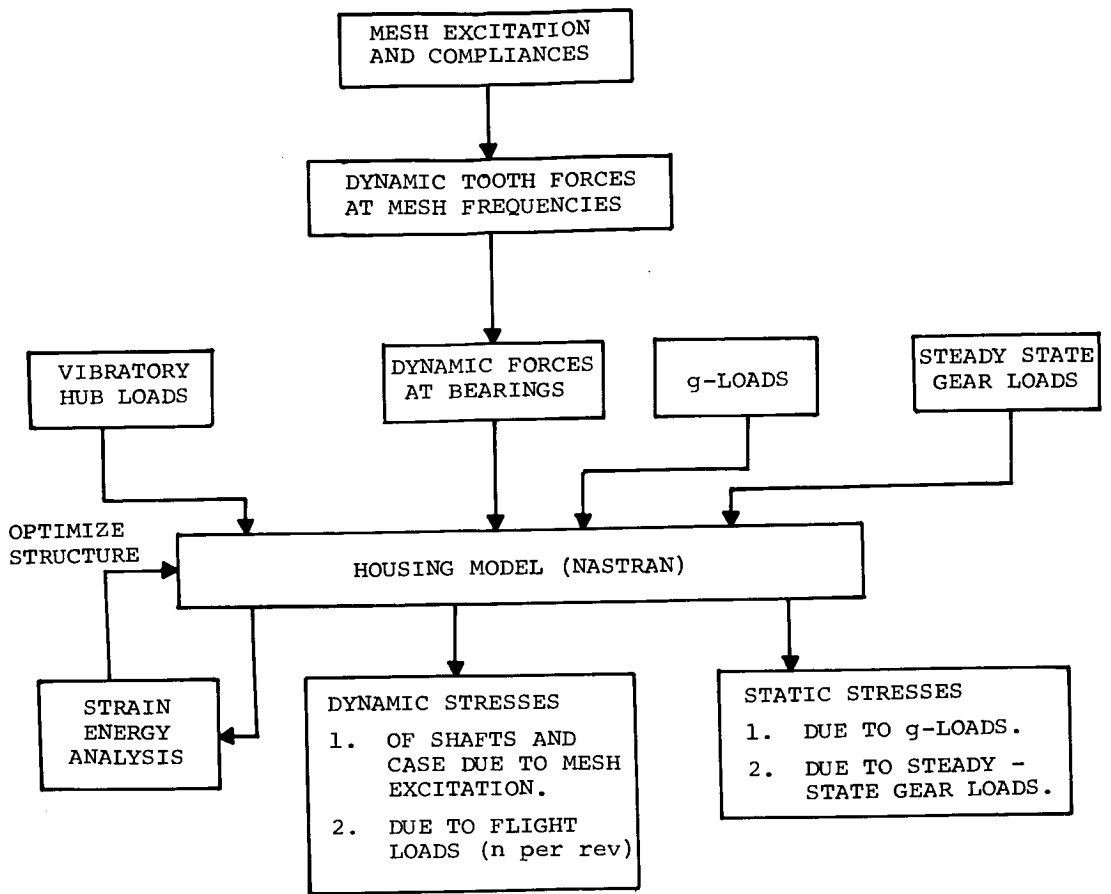

Figure 13. Flow Diagram of NASTRAN Stress Analysis.

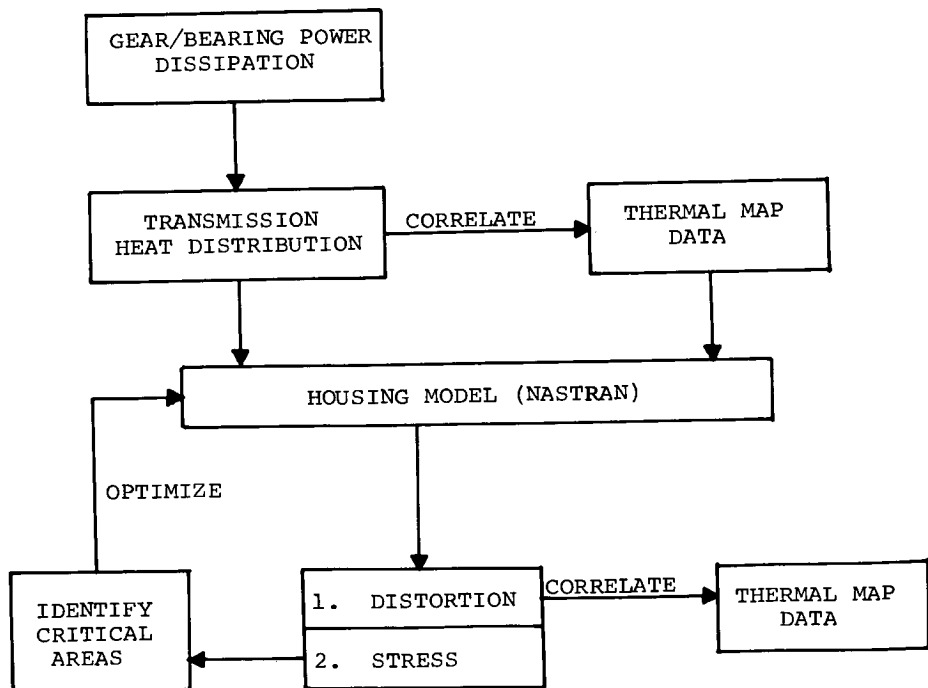

Figure 14. Flow Diagram of NASTRAN Thermal Analysis.