

PIONEER 10 JUPITER ATMOSPHERIC DEFINITION RESULTS - A SUMMARY

Dr. John Wolfe

NASA Ames Research Center

DR. WOLFE: I will talk about some of the Pioneer 10 results and also about what I think are some of the ramifications of those results with regard to technology and with regard to questions that I think this group ought to address during the next few days.

I will make some introductory remarks, Arv Kliore, who is the PI for the occultation experiment on Pioneer 10 will present some of his data and then I will make some concluding remarks.

Prior to the encounter of Jupiter by Pioneer 10, I was assured by many people, including our public relations office, that Pioneer 10 would answer all the questions with regard to Jupiter. In fact, if you read our project approval document you would swear that another mission is not needed. I assured these people that I felt that Pioneer 10 would more than likely raise many more questions than it answered and I am happy to report that is indeed, the case.

So, I would like to proceed to one of the things that Dan Herman mentioned this morning with regard to a cooperative Jupiter orbiter program with ESRO using the Pioneer H spacecraft, plead for you to consider the rationale during this workshop, the possibility and the justification and the possible need for a very simple probe associated with that mission.

I have listed on Figure 2-12 the rationale for the Jupiter orbiter mission with a probe using the Pioneer-class spacecraft. The fundamental reasoning is that one can do both a probe and an orbiter mission with this spacecraft, because for a Jupiter mission one is not weight restricted. The rationale for the probe is based on the improved ephemeris resulting from the Pioneer 10 flyby, which now permits planning for entry at a shallow angle and, therefore, reducing the peak heating loads; secondly, we may have an improved atmospheric model.

**PIONEER JUPITER
ORBITER/PROBE MISSION**

- **PIONEER CLASS JUPITER MISSIONS NOT WEIGHT RESTRICTIVE**
- **RATIONALE BASED ON PIONEER 10 RESULTS**
 - **IMPROVED EPHEMERIS**
 - **IMPROVED ATMOSPHERIC MODEL**
- **OBJECTIVES**
 - **DIRECT ATMOSPHERIC OBSERVATIONS**
 - **MAGNETOSPHERIC SURVEY**
 - **MAGNETOTAIL OBSERVATIONS**

The objective for the probe is direct, in-situ, atmospheric observations. I think that some of the more interesting regions in the higher atmosphere are going to be very difficult to observe and that shows up on a later figure. The objective for the orbiter is a magnetospheric survey in which we are primarily interested in magnetotail observations. Now to Figure 2-13.

We are talking about trip times to Jupiter on the order of two and a half years with a total injected weight of 790 kilograms; for the orbiter we are talking about a spacecraft weight of 260 kilograms and a payload weight of about 30 kilograms. We want to achieve an orbit of about $6 \times 200 R_J$ and I will show that on another figure.

This is how the orbit period turns out; 129 days, and a ten-orbit design lifetime. The Jupiter orbiter people have always considered this to be a minimum on Jupiter orbiter missions. The probe this mission could carry - and we are going to get a lot more details on this throughout the rest of the workshop - is on the order of 132 kilograms. Payload weight, and this may be optimistic, is 15 kilograms. (It may be more like ten.) So, one has to consider for an early Jupiter probe mission what can be done with ten to fifteen kilograms; and, in particular, what can be done to get first order data knowing that more sophisticated probe missions would be flown in the future. We have been considering communications from the probe via the orbiter. In the case of Pioneer-Venus, we are communicating from the probe directly to Earth. Because of Jupiter's distance we must relay through the bus spacecraft using data rates in the order of twenty bits per second with the objective of making observations down to twenty bars. There are some other problems associated with thermal control for the case of Jupiter. At twenty bars we expect temperatures comparable to those on the surface of Venus.

ORBITER/PROBE MISSION

- TRIP TIME ~ 2.3 YEARS
- TOTAL INJECTED WEIGHT, 790 Kg
- ORBITER
 - BASIC SPACECRAFT WEIGHT, 260 Kg
 - PAYLOAD WEIGHT, 30 Kg
 - 6 X 200 R_J ORBIT
 - 129 DAY ORBIT PERIOD
 - 10 ORBITS DESIGN LIFE
- PROBE
 - TOTAL WEIGHT, 132 Kg
 - PAYLOAD WEIGHT, 15 Kg
 - COMMUNICATIONS VIA ORBITER AT ~ 20 BPS
 - OBSERVATIONS DOWN TO 20 BARS

Figure 2-14 shows the probe entering and the bus spacecraft coming around and communicating with the probe. Then, as shown in the figure, after the probe mission is over, the spacecraft is heading out along the dawn meridian. This is particularly useful to the particles and fields magnetospheric survey of the magnetotail of Jupiter with the orbiter. If one was to dedicate a fly-by mission to Jupiter in order to investigate the far-down tail of Jupiter where, perhaps, a lot of the magnetospheric physics are really going on, then you are passing so far away from Jupiter that you are not doing a good job with Jupiter itself.

The orbiter, on the other hand, puts the line of apsides (Figure 2-15) along the dawn meridian. The $200 R_J$ apoapsis allows us to get beyond the shock front and to investigate both the shock and the magnetopause. We would raise the periapsis up to something in the order of four to six R_J simply to keep the radiation levels down so that we can last for ten orbits. The orbits then swing around toward the tail and, essentially, we are back in the tail after ten orbits. This takes on the order of three years or so.

Figure 2-16 is a picture of the Pioneer spacecraft as it presently exists with three additions: a toroidal tank to carry the fuel for making maneuvers, the deboost, the probe, right behind it, and the communications antenna for the link with the probe. The main part of the spacecraft is unchanged from the present Pioneer 10-11 configuration.

Now we come to the problems. Figure 2-17 is a plot of Arv Kliore's data on the occultation experiment as reported in Science. This is Guido Munch's point which I put around one atmosphere; (perhaps it should be a little bit higher, but because of my particles and fields and nuclear physics background, I like to draw nice straight lines between two points that I know). In addition to that I put the region on the figure where one sees the peak

PIONEER JUPITER ORBITER/PROBE
APPROACH TRAJECTORY

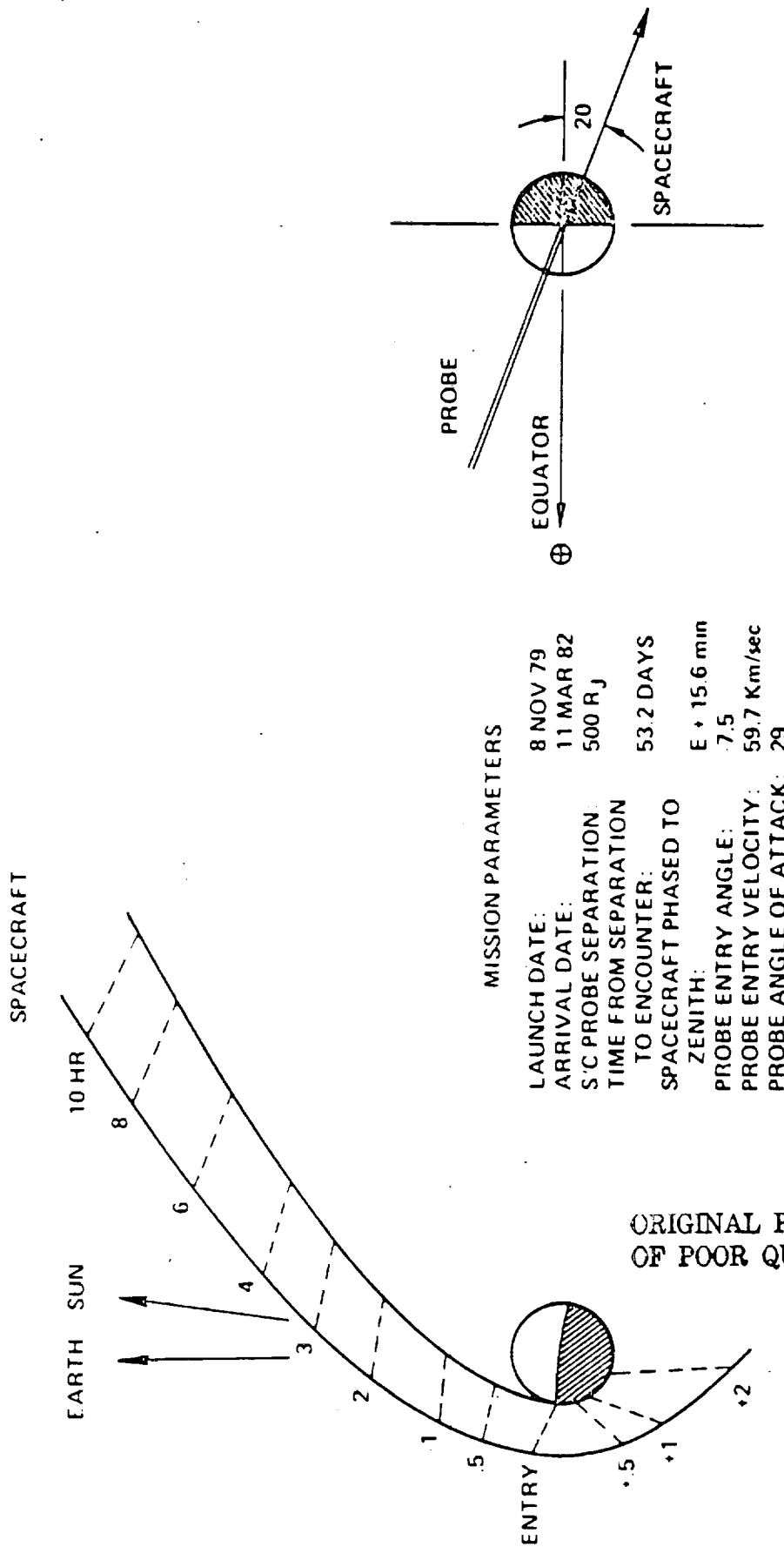

ORIGINAL PAGE IS
OF POOR QUALITY

Figure 2-14

APOAPSIS PASS

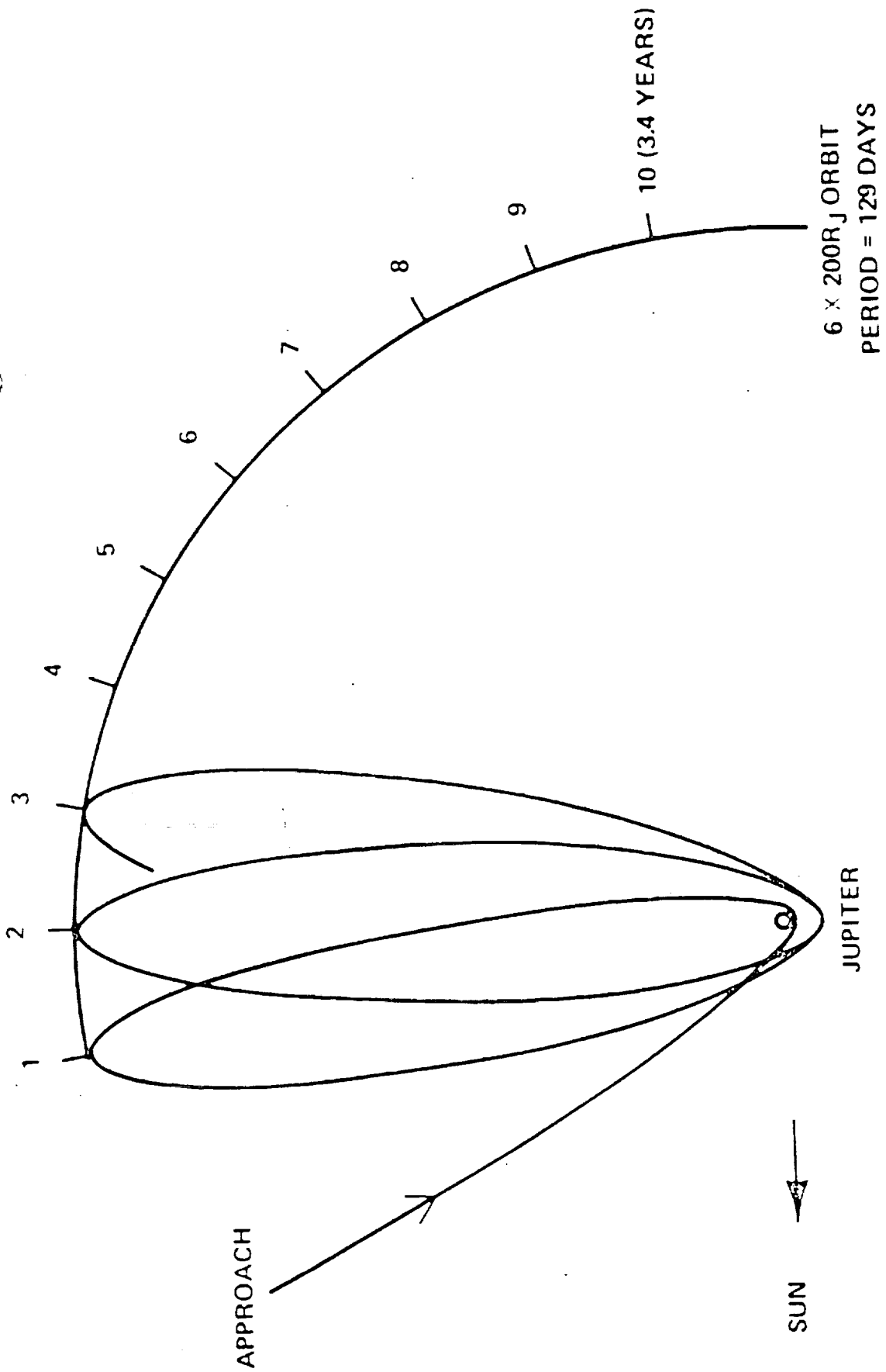
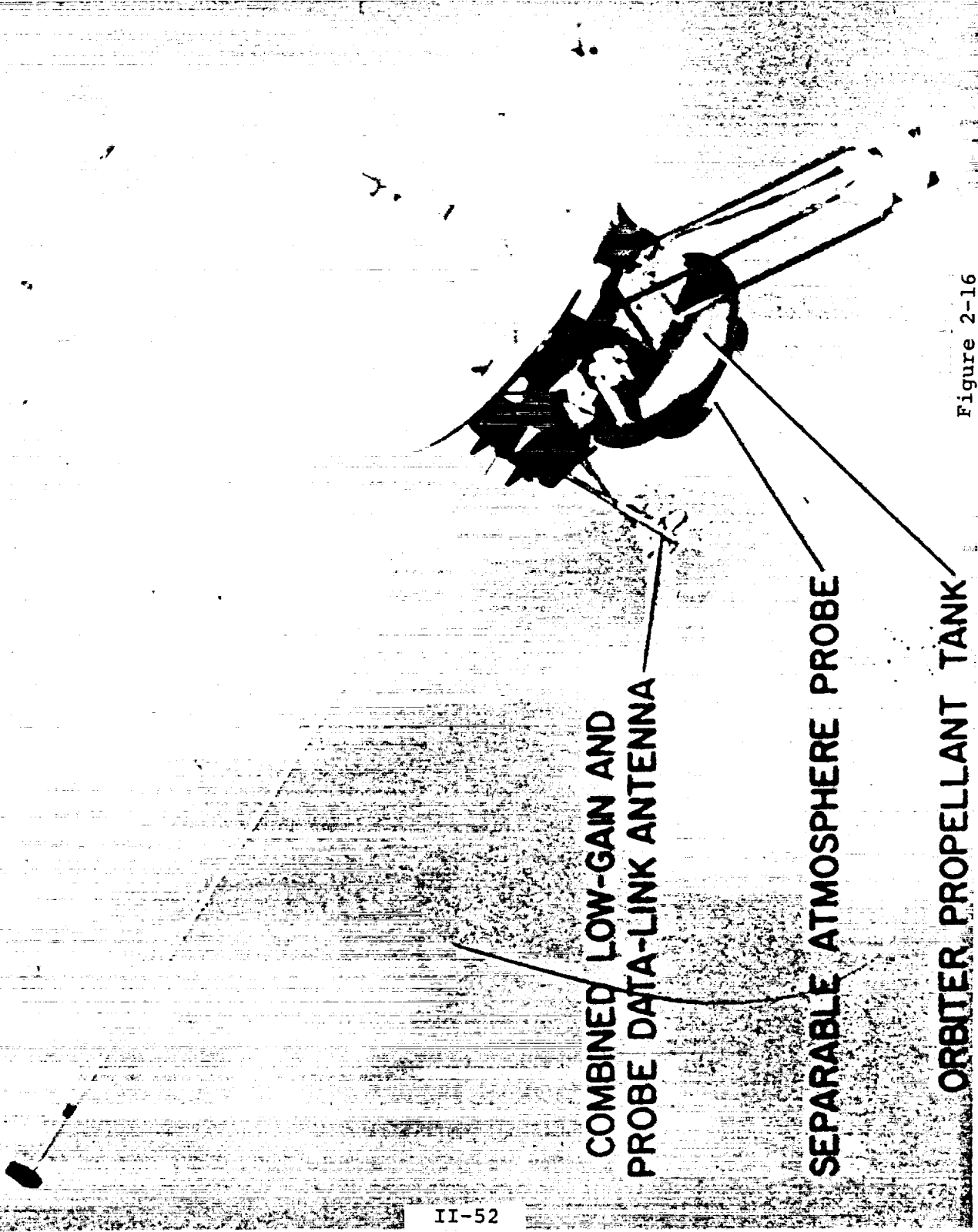

Figure 2-15

MODEL OF PIONEER OUTER PLANETS ORBITER/PROBE



II-52

Figure 2-16

ORIGINAL PAGE IS
OF POOR QUALITY

JUPITER ATMOSPHERE MODELS

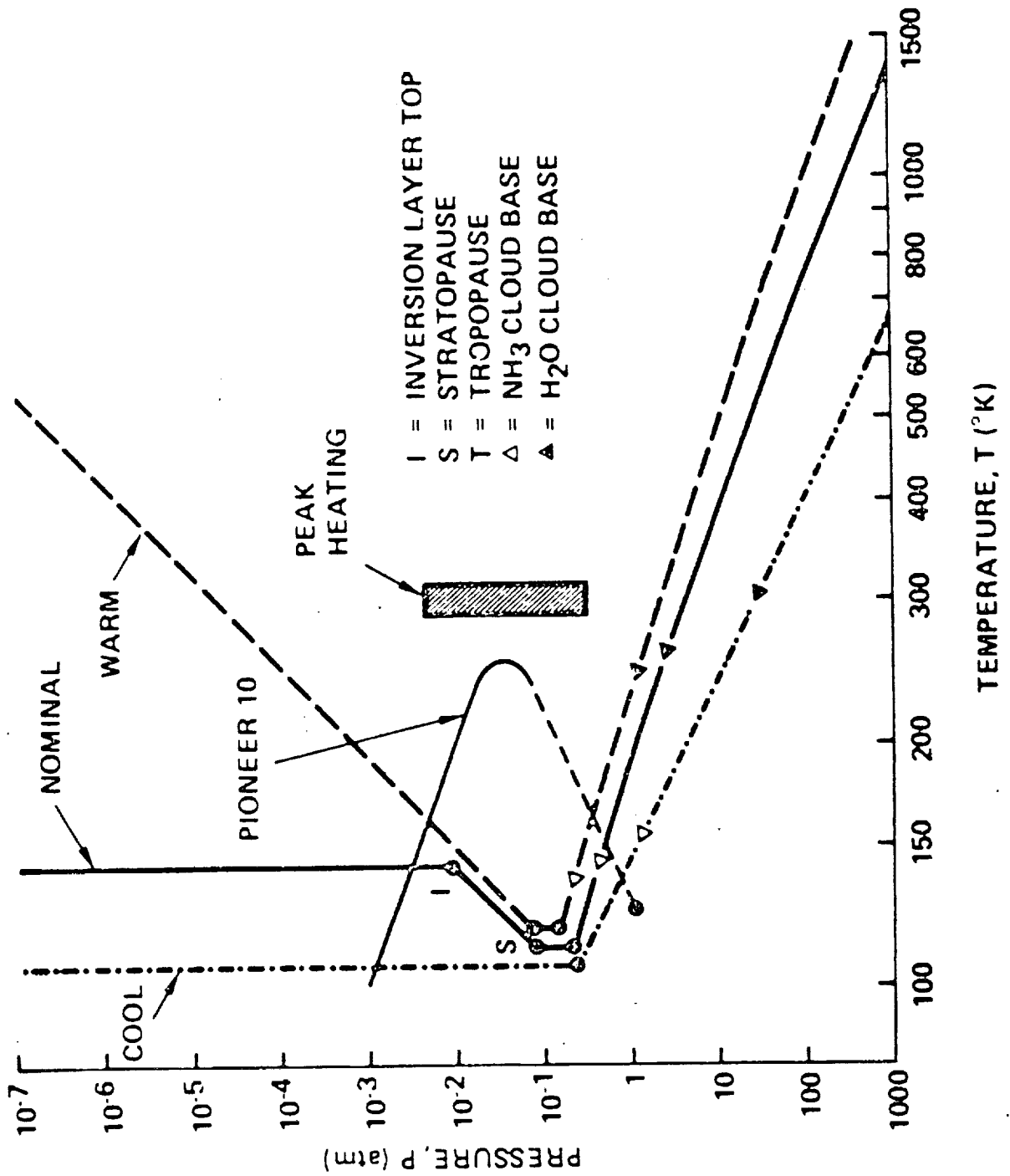

Figure 2-17

heating with regard to an entry probe. So what is happening in the lower atmosphere really doesn't affect the heatshield very much. I have also put on this figure the cool, the nominal and the warm NASA model atmospheres for Jupiter.

I would like you to keep in mind the cool, nominal and warm model atmospheres and, also, roughly the region where the peak heating occurs. With that, I will ask Arv Kliore to discuss some of his results.

DR. ARVYDAS KLIORE: As you know, these occultation measurements contribute to the design of the probe entry structure and heatshield; depending on the warm or cold temperatures at the upper levels of the lower atmosphere. You also know that these measurements are controversial at the moment, because the results don't agree with anybody else's work, and that is not a very good position to be in.

I would like to rapidly go through a discussion of how our results are obtained, and indicate the sort of confidence, or lack thereof, we have in all aspects of the results.

Figure 2-18 shows where the occultation measurements were made. The entry measurement was made in the northern hemisphere on 27° north latitude, between a zone and a belt; just on the sun side of the evening terminator. The exit measurement was made in the north polar area about 59° in latitude, on the dawn terminator.

Figure 2-19 shows the received power level of the signal as the radio beam was entering the atmosphere. There are two things I would like to point out: one is the presence of two signal drop-outs in the region where one expects the ionosphere. This indicates that the probe was far enough behind the planet, in this case about 220,000 kilometers, and that the

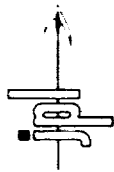

PIONEER 10 OCCULTATIONS

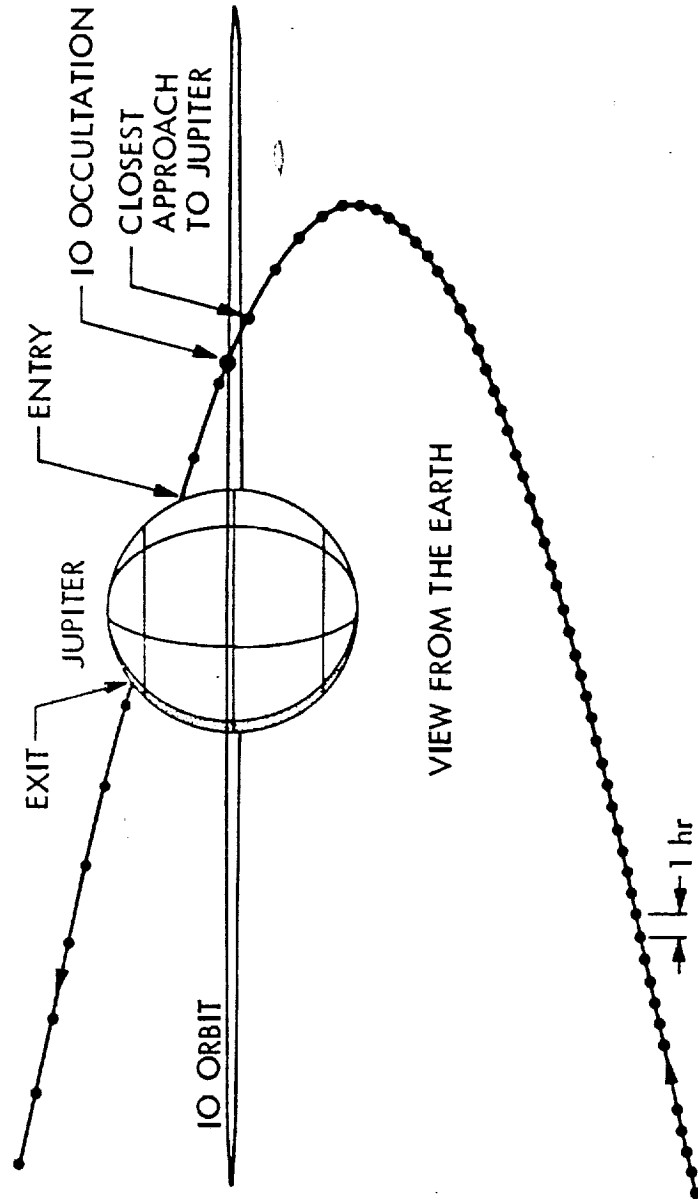
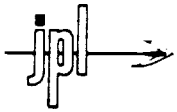

Figure 2-18



PIONEER 10 JUPITER ENTRY

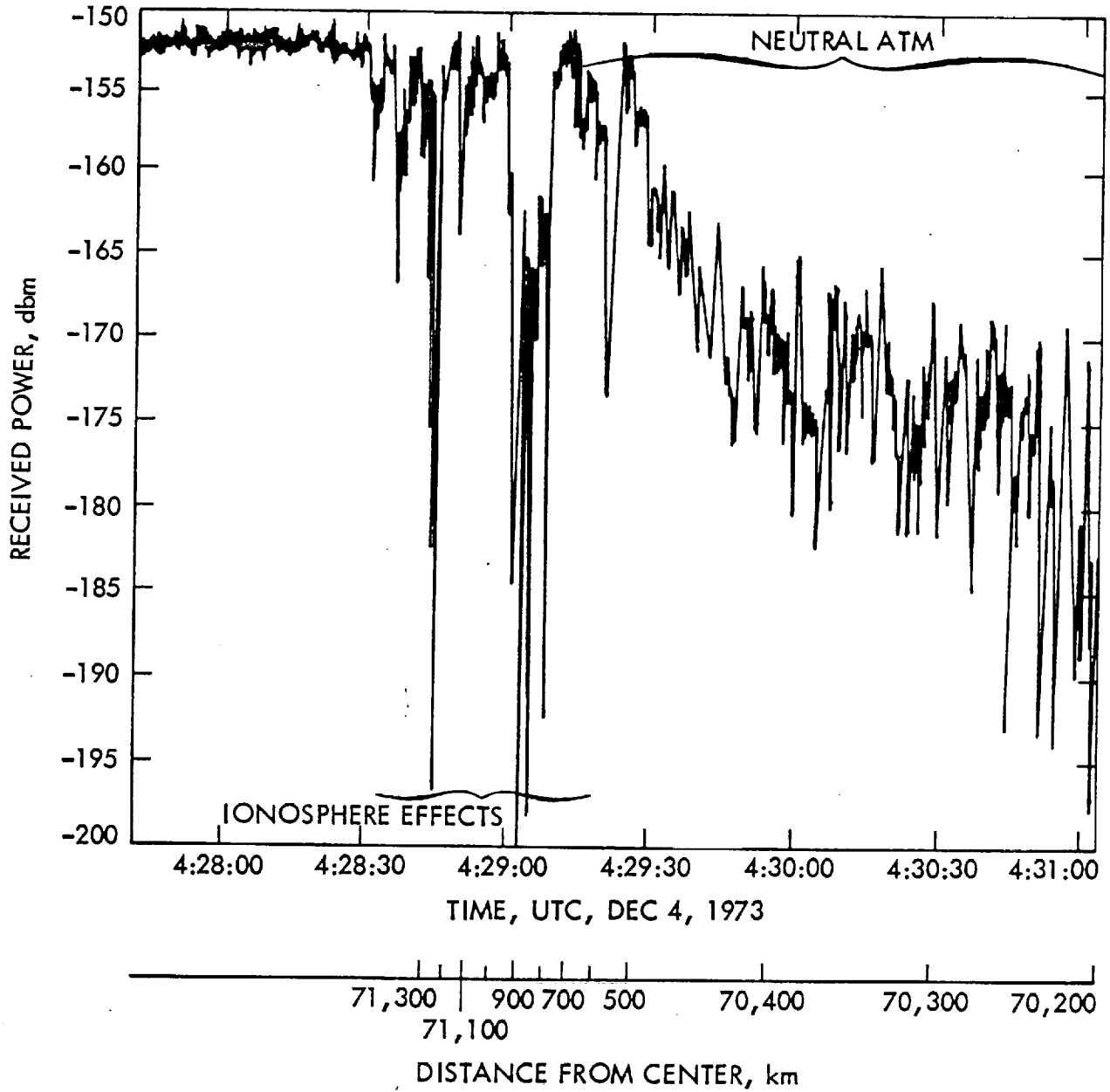

Figure 2-19

ionospheric layers had gradients sharp enough to cause caustics and to induce multi-path propagation.

The other point I want to mention is the long track of the signal in the neutral atmosphere which, as we shall see, corresponds to getting down to pressure levels of two and a half to three atmospheres for nominal-type compositions. This also, I think, indicates that there is less ammonia in the lower atmosphere than we expected because, before the experiment was performed, we thought that with the nominal amounts of ammonia in the atmosphere the signal would be totally absorbed by the time we get to about one half atmosphere. This did not happen; therefore, we think there is less ammonia.

The basic result which we obtained without any assumptions, is the refractivity in the atmosphere, from the phase changes in the signal. We don't use the amplitude because we know it is perturbed by either turbulence or absorption by gases. We know that the phase is affected only by refraction in the atmosphere and should not be affected by the presence of any aerosols, scatterers, or absorbers.

Figure 2-20 is a plot of the refractivity in N units, which is simply the index of refraction minus one $\times 10^6$ as a function of distance from the center.

I would like to point out that this curve is not smoothed. It was obtained by connecting adjacent points obtained at intervals of about a tenth of a second in this case. This corresponds variously to a resolution from about two kilometers to less than a couple of hundred meters in the lower atmosphere.

I would also point out that at the S-Band wavelengths, at a distance of about 220,000 kilometers, the Fresnell zone size which is the effective width of the radio beam as it's passing

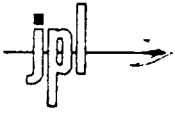

PIONEER 10 JUPITER ENTRY

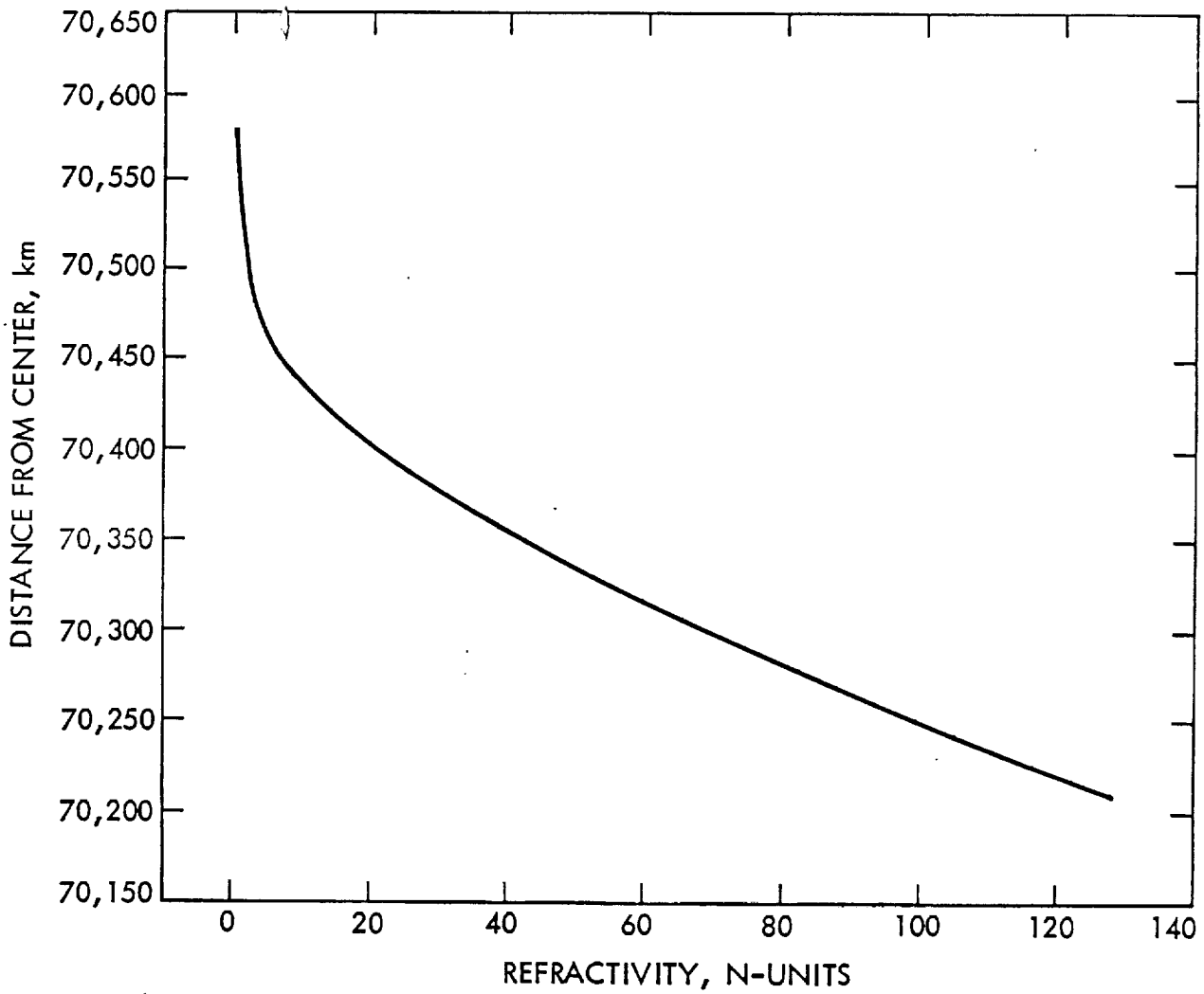

Figure 2-20

through the atmosphere, is about five to six kilometers, so there is an averaging effect in the atmosphere of about five or six kilometers.

DR. DONALD HUNTEN: Arv, can you persuade your computer to re-plot those curves on a semilog scale; it'd be an awful lot more valuable to the rest of us.

DR. KLIORRE: Semilog in what direction?

DR. HUNTEN: Log of refractivity versus height.

DR. KLIORRE: Well, I can supply you or anybody else with the numerical data in which case you can plot it any way you want. From that point on we must make an assumption of the composition because the refractivity of one gas is different from another, and of course, their molecular weights are different. In order to get properties like temperature and pressure we must first find the density by assuming the composition and then integrate the refractivity, or the density obtained from the refractivity, downward, using the hydrostatic equation to obtain the pressure; then use the perfect gas law to obtain the temperature.

Figure 2-21 shows a temperature profile for a composition of 85% Hydrogen and 15% Helium by number. Also shown are three initial temperatures which we must assume in order to start the integration of the hydrostatic equation. Although I don't show it on this curve, the varying composition between hydrogen and helium does not really make a lot of difference.

Figure 2-22 shows the temperature profile for the early morning or nighttime measurement, at a solar-zenith angle of 94° . The curve has a general characteristic very similar to the daytime one, except that there is no bump in the upper region. I

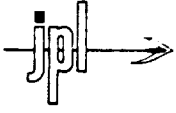

PIONEER 10 JUPITER ENTRY

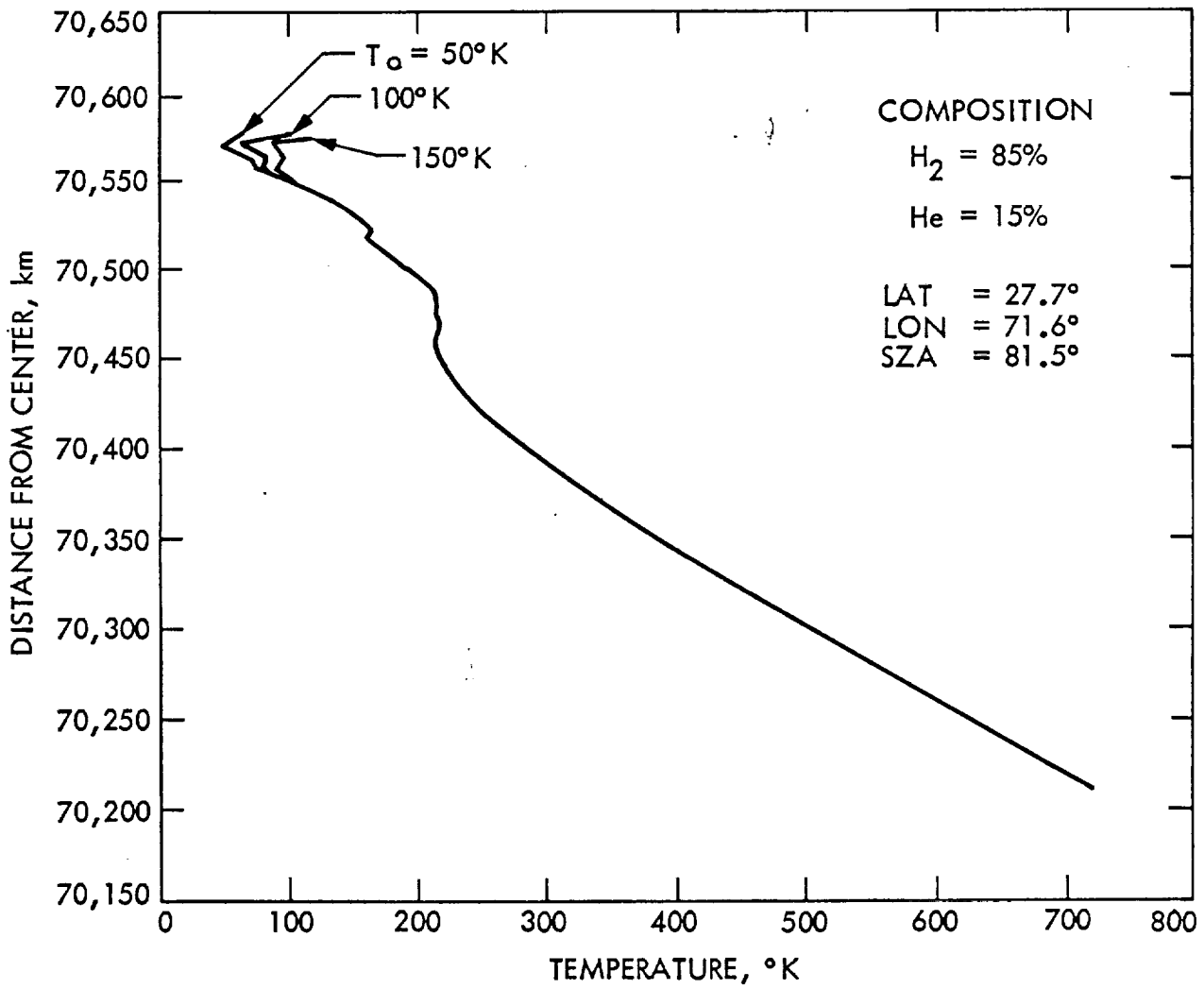
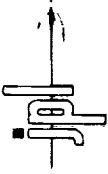

Figure 2-21



PIONEER 10 JUPITER EXIT

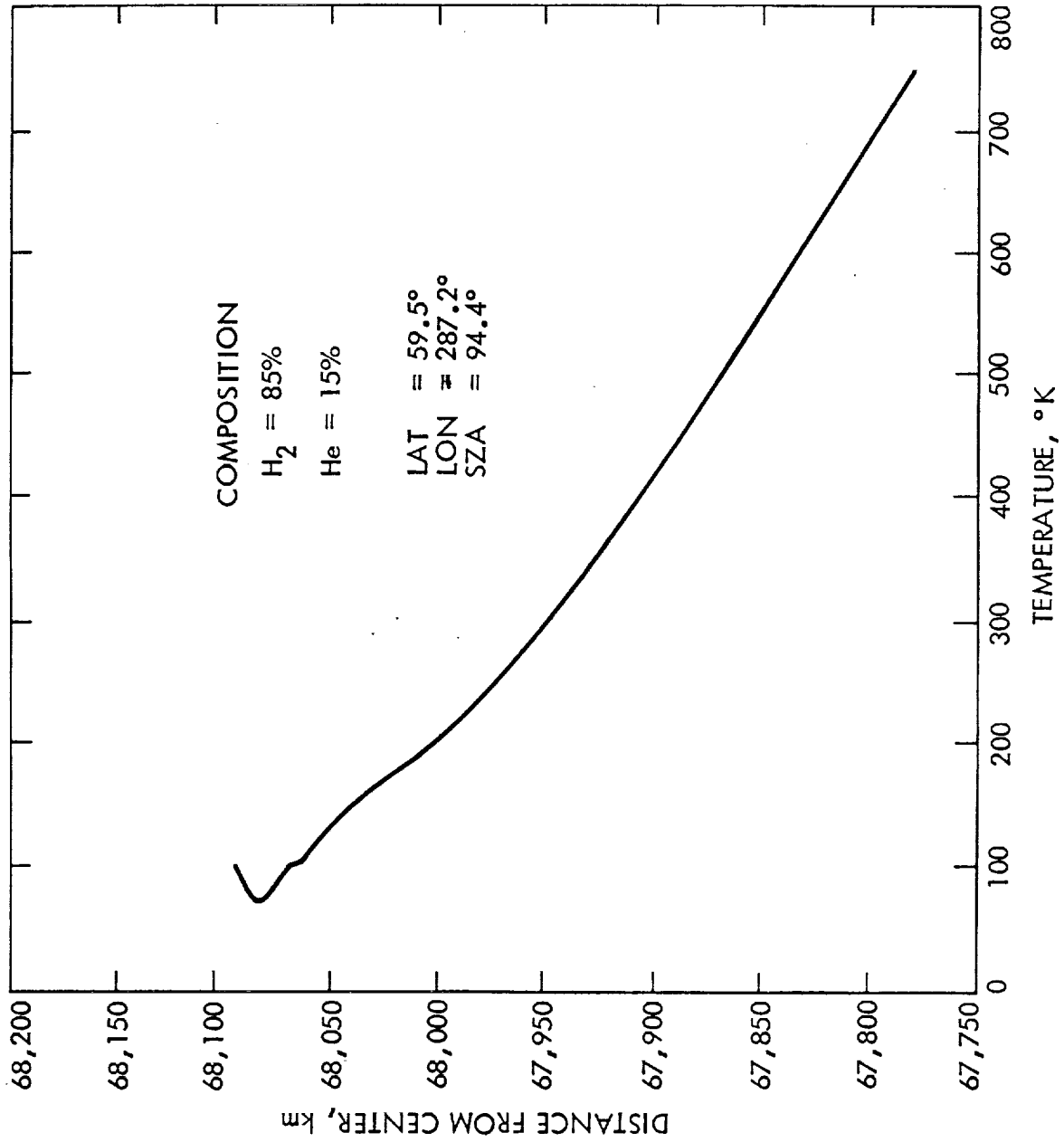

Figure 2-22

interpret the absence of a bump on this curve as an effect of lack of solar illumination. In Figure 2-23 we show these curves plotted on a common scale. There are differences in the lower atmosphere which are caused by the different acceleration of gravity with height at the higher latitude than lower latitude. Because, in the case of Jupiter its rapid rotation is very important in determining the attraction of gravity.

On the left-hand of the figure there is a little box which represents the summary of Earth-based and in this case Pioneer 10 radiometer measurements indicating temperatures of 130° to 150° at about one-half atmosphere of pressure. The cross-hatched area shows the possible extent of a dust or cloud or aerosol layer stretching from about one millibar to fifty millibars. I think there is something there because in the daytime it absorbs solar radiation, causing an increase in temperature of up to about fifty degrees and in the nighttime it does not. There might be some way to interpret the infrared spectroscopy results as being perturbed by multiple scattering and other effects in the cloud layer. That does not, however, take care of the radio observations.

I would like to come back to the composition question. In order to reconcile the temperatures derived from our results with those derived from the spectroscopy, one would have to decrease the refractivity of the mixtures. Our refractivity that we measure should represent more gas than it does. The problem with that is that, assuming pure Hydrogen and Helium, we are using the least refractive gases with the least molecular weight we could possibly have in the atmosphere. The refractivities of Hydrogen and Helium are very low compared to gases like ammonia, methane, carbon dioxide, water, etc. Therefore, whatever one adds to the composition in order to investigate the behavior is not going to make things better; it is going to make them worse.

PIONEER 10 OCCULTATION

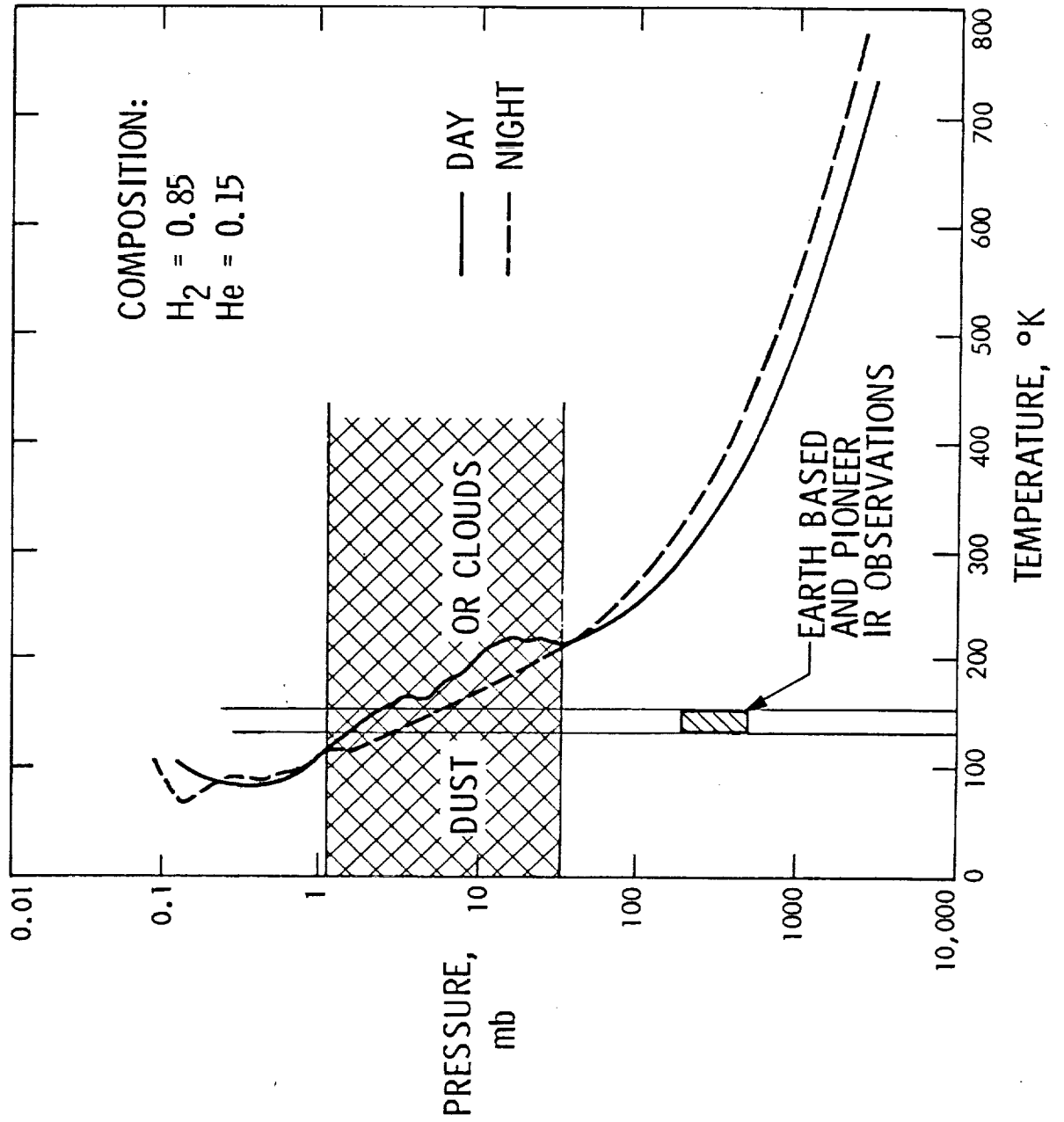

One thing we did is to try to adjust the specific refractivities of the gas mixtures; keep the molecular weight the same as Hydrogen and Helium in these amounts, but simply to decrease the specific refractivity of the gas. When we did that, we had to keep decreasing it by a factor of about twenty or so in order to get a temperature of 150°K at 100 to 200 millibars.

So, at the moment there is no way to explain the discrepancy, by adjusting the composition. One of our current jokes is that we have discovered a new element, zeron, which has zero refractivity, behaves as a perfect gas, and has a molecular weight of two.

There have been other possible explanations advanced. One is the presence of ionized particles in the lower atmosphere, mixed with the neutral atmosphere, produced by bombardment by BEV protons, or continuous electrical discharges in a thunderstorm. The problem with that is that even to counteract the presence of about ten n-units of neutral refractivity it would take about a million electrons per cubic centimeter. How these could be produced and kept in equilibrium with a neutral atmosphere is something I would not like to explain, because I don't have an explanation. So, the composition is not the answer. I don't believe it is the ionization hypothesis either. It probably has to do with the fact that the atmosphere of Jupiter is much more complicated than we or the spectroscopists have thought and that the common explanation to both of our results has to take into account more sophisticated models and more sophisticated analysis of data.

Let me just discuss, in support of that hypothesis, the electron density in the ionosphere of Jupiter, which was derived by Dr. Fjeldbo at JPL. The profile shows many peaks. This, to me at least, indicates that there are many species of ions that are creating those sharp layers of electrons and, hence, that there are probably things going on which we don't quite know about. Of course, we can't tell what these ion species are; we are waiting for the probe or a skimmer orbiter to tell us that. Anyway,

it is not simple, it's not just hydrogen ionizing at one height.

DR. HUNTEN: It seems a lot like the sporadic E on the Earth, except that it is spread out.

DR. KLIORRE: Yes. Well, the entire ionosphere of the Earth would fit in the first 1000 km of the profile.

Okay, let me finish. I would like to suggest, for one thing, that a study of the refractivity at S-Band wavelengths of gases like hydrogen and helium be independently performed at some institution which has the capability for doing so. This would tend to increase our confidence in our results, because now we are using refractivities derived from those measured at optical wavelengths and corrected for radio wavelengths. Other than that, I think we should continue to work together and try to resolve this problem because there is a discrepancy now with which neither we nor the spectroscopists can live, before it's resolved.

DR. HUNTEN: I would like to make a remark while you are transferring. This suggestion that ammonia is even rarer than you expected is an interesting one, too, because that in itself implies that the temperature is relatively low to freeze out the ammonia.

DR. KLIORRE: Well, that is one interpretation.

DR. WOLFE: I would like to make some concluding remarks. For example, I think all of us should consider, not only at this workshop but also with regard to mission analysis and NASA future planning, what bearing will Pioneer 11 have on some of the future probe missions. I think I can answer that in a couple of statements here, but we must also consider what Mariner-Jupiter-Saturn in '77 can do for us and, certainly, what can we do with regard

to not only groundbased but near-Earth space remote sensing with regard to Jupiter.

I think, from a technology point of view, there are two principal problems with regard to the probe itself. One is the entry problem from the heating point of view where the atmospheric model, of course, is very important. The second one is the trapped particle radiation levels that the probe is going to have to withstand in entering. I think, with regard to the latter, we'll probably be able to get a much better handle on this with Pioneer 11. Right now the radiation belt models from Pioneer 10 are very suspect inside three R_J jovian radial distance. We are going in to about 1.6 R_J with Pioneer 11. We are also going around the planet clockwise so we can get a good handle on the higher moments of the magnetic field; and get a good longitudinal survey with regard to the trapped radiation.

We are going to be closer to the planet. I think this may have some bearing on what S-Band occultation will have to say with regard to the ionosphere but I don't think we are going to be able to resolve the IR occultation problems with regard to the upper atmosphere.

And then, finally, I think that the heatshield people should consider the possible effects of a dust layer on entry; what does it do to the heatshield, particularly when it has unknown composition? I think the SX band will give a handle on the ionization with regard to lower levels, although I agree with Dr. Kliore; I don't see how you can get that kind of electron densities down there. So, I don't think that is going to help alleviate the situation either.

I put all these arguments together and it seems to me that if we can support a very, very simple probe on the Pioneer H mission with ESRO which does nothing more than enter and make temperature-pressure measurements it will be exceedingly important with regard to future missions. Thank you.

DR. RASOOL: Thanks, John. Dan Herman

MR. HERMAN: I have one question. It may be an unfair one, but does Guido have any model which tends to reconcile your data and his, any theories?

DR. KLIORE: He hasn't announced any model like that yet, but I do know by having private discussions with him that he cannot interpret his results satisfactorily without invoking some dust or scatterers. However, I don't think it is going to increase his temperature estimates by a factor of two.

DR. RASOOL: The trouble with Guido's results is that I've seen them interpreted by others, but not by him, as yet.