

MFS-22, 145-1

United States Patent [19]

[11] 3,854,097

James C. Fletcher et al.

[45] Dec. 10, 1974

[54] SELF-ENERGIZED PLASMA COMPRESSOR

3,718,836 2/1973 Bain et al. 313/63 X
3,757,518 9/1973 Bahr 313/63 X

[76] Inventors: **James C. Fletcher**, administrator of the National Aeronautics and Space Administration with respect to an invention of; **Edward L. Shriver**, 4505 Garth Rd., S.E., Huntsville, Ala. 35802; **Eduard B. Igenbergs**, Rauchstrasse 3, 8000 Munich 80, Germany

Primary Examiner—Alfred L. Brody
Attorney, Agent, or Firm—Wayland H. Riggins; L. D. Wofford, Jr.; John R. Manning

[22] Filed: **June 6, 1973**

[21] Appl. No.: **367,606**

[52] U.S. Cl. 328/233, 176/3, 313/63, 315/111

[51] Int. Cl. H01j 23/26

[58] Field of Search 328/233-238, 328/239; 313/62, 63; 176/3; 315/111

[56] References Cited

UNITED STATES PATENTS

3,225,236 12/1965 Meyer 176/3 X
3,677,889 7/1972 Coengen et al. 176/3

[57] ABSTRACT

A self-energized plasma compressor which compresses plasma discharged from a coaxial plasma generator. The device includes a helically shaped coil which is coaxially aligned with the center axis of the coaxial plasma generator. The plasma generator creates a current through the helical coil which, in turn, generates a time varying magnetic field that creates a force which acts radially upon the plasma. The coaxial plasma generator and helical coil move the plasma under high pressure and temperature to the narrow end of the coil. Positioned adjacent the narrow end of the coil are beads which are engaged by the plasma to be accelerated to hypervelocities for simulating mete-oids.

2 Claims, 2 Drawing Figures

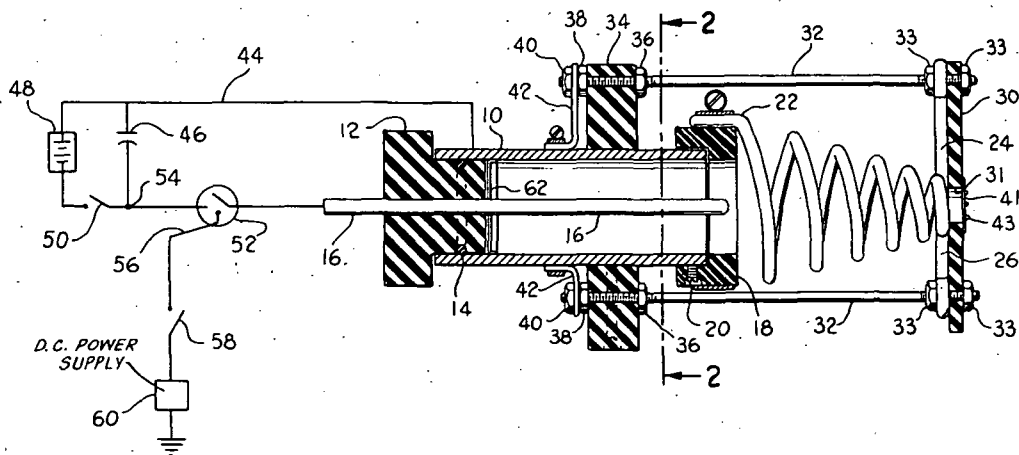

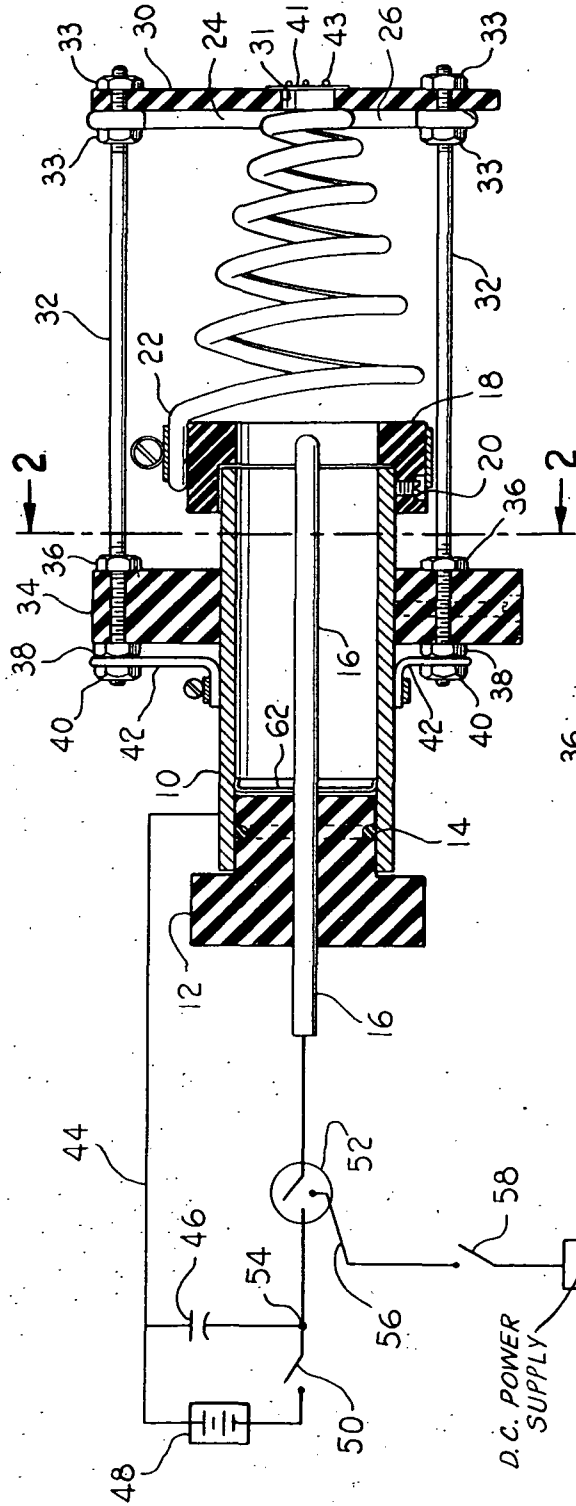

Fig. 1.

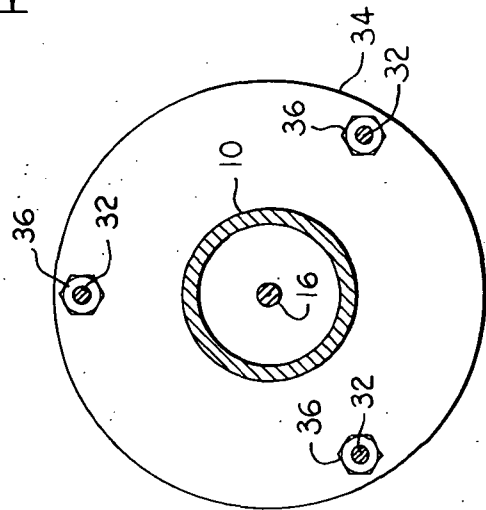

Fig. 2.

SELF-ENERGIZED PLASMA COMPRESSOR**ORIGIN OF THE INVENTION**

The invention described herein was made in performance of work under a NASA Contract, and is subject to the provisions of Section 305 of the National Aeronautics and Space Act of 1958, Public Law 85-568 (72 Stat. 435;42 U.S.C. 2457).

BACKGROUND OF THE INVENTION

This invention relates generally to a plasma generator and more particularly to a plasma generator constructed to propel small projectiles to hypervelocities.

Heretofore, in order to propel small objects, such as beads, at hypervelocities for simulating meteoroids that may be encountered while travelling in outer space, it has been necessary to propel such from chemical explosions, from electrically exploded wires, or from electrostatic accelerators. While these apparatus may be able to propel very small particles at hypervelocities, they are not satisfactory for larger particles.

Devices have been developed, such as shown in U.S. Pat. No. 3,579,028 and U.S. Pat. No. 2,992,345, for focusing plasma in order to obtain very dense high-velocity plasma bursts. However, such devices do not include a self-energized helical coil which moves the plasma to a narrow end of the coil for engaging objects to propel them at hypervelocities.

SUMMARY OF THE INVENTION

The plasma generator constructed in accordance with the present invention is a self-energized plasma compressor which compresses the plasma discharge from a coaxial plasma generator. This system includes a helical coil which is situated coaxially with the center axis of a coaxial plasma generator. The large diameter end of the helical coil extends around the outer end of a cylindrical electrode forming a part of the coaxial plasma generator and extends outwardly therefrom. The outer small diameter end of the helical coil is connected to the cylindrical electrode of the coaxial generator. Thus, when the plasma generated within the coaxial generator begins to leave the cylindrical electrode it forms an electrical path from the end of the rod electrode to the helical coil. Current begins to flow through the helical coil producing a time varying magnetic field which, in turn, creates a circular current within the plasma inside the coil. The interaction of this current density with the time varying longitudinal magnetic field creates a force which acts radially upon the plasma so as to compress the plasma towards the axis of the helical coil. During this compression the plasma is heated to a high temperature. By positioning beads on a thin film member, such as mylar, the plasma penetrates the film to propel the beads at hypervelocities.

Accordingly, it is an important object of the present invention to provide a plasma generator which can propel objects such as glass beads, at hypervelocities.

Another important object of the present invention is to provide a self-energized plasma compressor, which is simple in construction and can be reused with a minor amount of servicing.

Still another important object of the present invention is to provide a self-energized plasma compressor which heats and densifies plasma so as to allow such to

be expelled through a small opening to propel glass beads and the like at hypervelocities.

BRIEF DESCRIPTION OF THE DRAWINGS

FIG. 1 is a longitudinal sectional view, partially in schematic form, illustrating a self-energized plasma compressor constructed in accordance with the present invention, and

FIG. 2 is a cross-sectional view taken along line 2—2 of FIG. 1.

DESCRIPTION OF THE PREFERRED EMBODIMENT

Referring in more detail to the drawings, there is illustrated a plasma generator, which has a cylindrical elongated annular electrode 10 constructed of any suitable material, such as steel. An insulating plug 12 is carried on the inner end of the electrode 10 and has an O-ring 14 provided in an annular groove therein for producing a positive seal between the cylindrical electrode 10 and the plug 12. An elongated rod electrode 16 extends through the plug 12 along the longitudinal axis of the cylindrical electrode 10. The outer end of the rod electrode 16 extends slightly beyond the cylindrical electrode 10.

An insulating ring 18 is carried on the outer end of the cylindrical electrode 10 and is secured thereto by a setscrew 20. The opening in the insulating ring 18 is of the same diameter as the internal diameter of the cylindrical electrode 10.

An electrically conductive helical compressor coil 22 has one end secured to the outer surface of the insulating ring 18 and extends outwardly in a helical spiral. The helical spiral has a large diameter adjacent the insulating ring 18 and such decreases towards the outer end. The outer end of the helical coil 22 is electrically connected to conductors 24 and 26 which extend radially outwardly from the longitudinal axis of the device. The conductors 24 and 26 have looped outer ends through which bolts 32 extend for securing such to a circular insulating spacer plate 30. The ends of the bolts 32 have threads thereon, upon which nuts 33 are carried so that the looped end of the conductors 24 and 26, as well as the spacer plate 30 can be sandwiched therebetween for securing such together. The elongated bolts 32 extend rearwardly through another non-conductive coil spacer plate 34 which is carried on the cylindrical electrode 10. Nuts 36 and 38 are carried on opposite sides of the spacer plate 34 for securing the bolts thereto. The outer end of the bolt 32 has a nut carried thereon for securing one end of an electrical conductor 42 thereto. The other end of the electrical conductor is connected to the cylindrical electrode 10.

The outer spacer plate 30 has a hole 31 centrally located therein, which is in alignment with the small diameter end of the helical coil 22. Extending over the hole 31 is a thin mylar member 41 which has beads 43 positioned thereon. These beads 43 are the beads which are desired to be propelled at hypervelocities.

In order to energize the plasma generator an electrical conductor 44 is connected between the cylindrical electrode 10 and one side of a capacitor bank 46 shown schematically as a single capacitor. Also, connected to the same side of the capacitor bank 46 is the output of a D.C. power supply 48. The other side of the D.C. power supply 48 is connected through a switch 50 to

one electrode of an ignitron switch 52. Interposed between ignitron switch 52 and the switch 50 is a junction 54 to which the other side of the capacitor bank 46 is coupled. A control electrode 56 of the ignitron switch 52 is connected through a switching mechanism shown schematically at 58 to one side of a D.C. power supply 60. The other side of the D.C. power supply 60 is grounded.

In operation, upon closing the switch 50 of the D.C. power supply 48 such causes the capacitor bank to charge to a predetermined level. When switch 58 is closed such, in turn causes the ignitron switch 52 to close. Upon closing of the ignitron switch 52 the capacitor bank 46 discharges through the central electrode 16, a circular aluminum foil 62, cylindrical electrode 10 back through lead 44 completing the circuit. As current flows through the aluminum foil 62 such causes the foil to be heated and ionized. When the foil 62 is ionized it forms a plasma which is accelerated out of the cylindrical electrode 10 by the magnetic field surrounding the elongated electrode 16. As this plasma exits from the insulating ring 18 it forms an electrical path from the end of the elongated electrode 16 to the helical coil 22. Current begins to flow through the helical coil 22 creating a longitudinal magnetic field within the coil 22 which varies in time with the potential applied to the electrodes 10 and 16 of the coaxial plasma generator.

This time varying magnetic field creates a circular current within the plasma inside the coil 22. This circular current interacts with the axial magnetic field and creates a radial force by which the plasma is contained within the coil. Since the plasma leaves the cylindrical electrode 10 of the coaxial generator with a velocity component directed along the longitudinal axis, it is compressed into the narrow end of the compressor coil 22.

When the potential applied to the rod electrode 16 and the cylindrical electrode 10 of the coaxial generator begins to decrease the magnetic field created by the helical coil 22 also begins to decrease, and the current induced in the plasma by the magnetic field changes direction. Since the magnetic field has not changed direction but the current in the plasma has, the force on the plasma tends to drive it away from the longitudinal axis and the plasma is forced out of the coil 22 in a direction perpendicular to the longitudinal axis of the coil.

During the compression the dense plasma in the narrow end of the coil 22 is under high pressure and temperature, and is thus available for use as a high pressure gas. This plasma ruptures the thin mylar foil 41 and strikes the beads causing the beads 43 to be propelled at a hypervelocity.

During the energization of the plasma compressor it is positioned within a vacuum chamber which surrounds the entire apparatus. In one particular test the beads which are expelled when the mylar member 41

is ruptured by the plasma are propelled towards a target carried on an inner end of the vacuum chamber. This target may be any suitable material, such as the skin of a spacecraft, and from these tests it can be determined if meteoroids will damage or penetrate such in space flight. Of course, other tests could be performed on similar objects. The compressor could also be used for providing a dense high temperature plasma that may possibly have many applications and use.

While a preferred embodiment of the invention has been described using specific terms, such description is for illustrative purposes only, and it is to be understood that changes and variations may be made without departing from the spirit or scope of the following claims.

What is claimed is:

1. An apparatus for producing high temperature compressed plasma comprising:

- a. an elongated cylindrical first electrode;
- b. a central rod electrode disposed coaxially of said first electrode out of contact therewith;
- c. an electrically conductive element extending between said central rod electrode and an inner end of said first electrode;
- d. means for applying a high voltage to said first electrode and said central rod electrode for causing said electrically conductive element to ionize producing a plasma which is accelerated out of the outer end of said first electrode;
- e. an insulating connecting means carried on an outer end of said first electrode;
- f. an elongated electrically conductive helical coil having a large diameter end and a small diameter end;
- g. said large diameter end of said helical coil being connected to said connecting means and said small diameter end being spaced longitudinally therefrom;
- h. means for electrically connecting said small diameter end of said helical coil to said first electrode;
- i. said helical coil being in axial alignment with said elongated cylindrical first electrode so that a current path is formed between an outer end of said central rod electrode and said helical coil as said plasma is accelerated out the outer end of said first electrode producing current flow through said helical coil which in turn produces a time varying magnetic field that compresses said plasma adjacent said small diameter end of said coil;
- j. whereby a source of high temperature compressed plasma is produced adjacent said small diameter end of said helical coil.

2. The apparatus as set forth in claim 1, wherein said electrically conductive element is a thin circular aluminum member which is ionized by said high voltage.

* * * * *