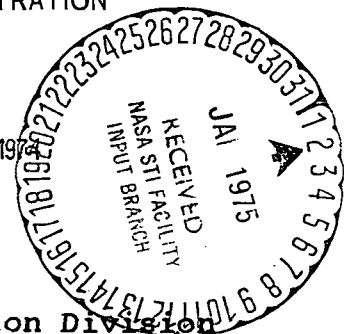




NATIONAL AERONAUTICS AND SPACE ADMINISTRATION

WASHINGTON, D.C. 20546



DEC 30 1974

REPLY TO ATTN OF: GP

TO: KSI/Scientific & Technical Information Division
Attn: Miss Winnie M. Morgan
FROM: GP/Office of Assistant General Counsel for Patent Matters
SUBJECT: Announcement of NASA-Owned U.S. Patents in STAR

In accordance with the procedures agreed upon by Code GP and Code KSI, the attached NASA-owned U.S. Patent is being forwarded for abstracting and announcement in NASA STAR.

The following information is provided:

U.S. Patent No. : 3,854,113
Government or Corporate Employee : The Boeing Company, Kennedy Space Center, FL
Supplementary Corporate Source (if applicable) :
NASA Patent Case No. : KSC-10,723-1

NOTE - If this patent covers an invention made by a corporate employee of a NASA Contractor, the following is applicable:

YES [X] NO [ ]

Pursuant to Section 305(a) of the National Aeronautics and Space Act, the name of the Administrator of NASA appears on the first page of the patent; however, the name of the actual inventor (author) appears at the heading of column No. 1 of the Specification, following the words "...with respect to an invention of ..."

Bonnie L. Woerner

Bonnie L. Woerner
Enclosure

NASA-Case-KSC-10723-1 VARIABLE RESISTANCE CONSTANT TENSION AND LUBRICATION DEVICE Patent (NASA)

7 p CSCL 13I

N75-13265

Unclas

00/37

05529

K5C-10,723-1

# United States Patent [19]

[11] 3,854,113

Fletcher et al.

[45] Dec. 10, 1974

## [54] VARIABLE RESISTANCE CONSTANT TENSION AND LUBRICATION DEVICE

[76] Inventors: **James C. Fletcher**, Administrator of the Natl. Aeronautics and Space Administration with respect to an invention by; **Henry J. Smith**, 2210 MacFarland Dr. Brevard, Fla. 32922

[22] Filed: **Apr. 4, 1973**

[21] Appl. No.: **347,952**

[52] U.S. Cl. .... 338/75, 338/97, 338/162

[51] Int. Cl. .... H01c 5/02

[58] Field of Search ..... 338/75, 97, 162, 174, 171, 338/170, 169, 167

### [56] References Cited

#### UNITED STATES PATENTS

2,085,404	6/1937	Vollenbroek .....	338/75
2,357,433	9/1944	Side .....	338/75
2,896,184	7/1959	McCabe .....	338/97
2,931,002	3/1960	Schendel .....	338/174 X

*Primary Examiner*—J. V. Truhe

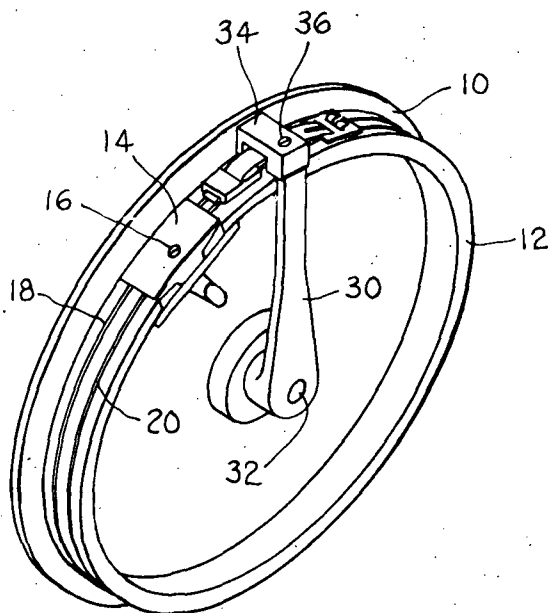
*Assistant Examiner*—David A. Tone

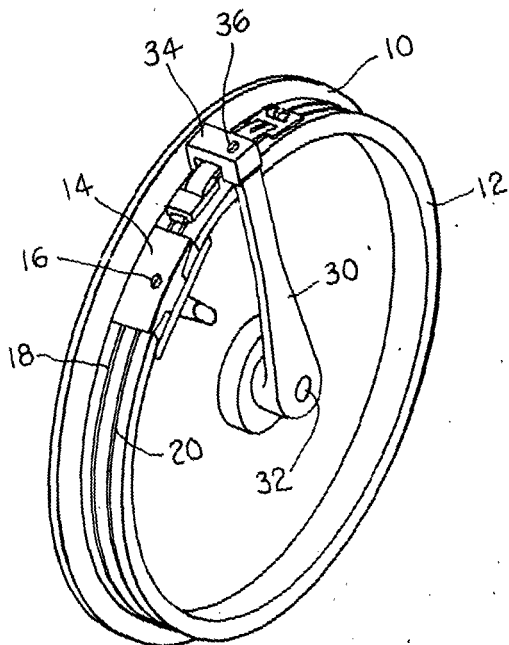
*Attorney, Agent, or Firm*—James O. Harrell; John R. Manning

### [57] ABSTRACT

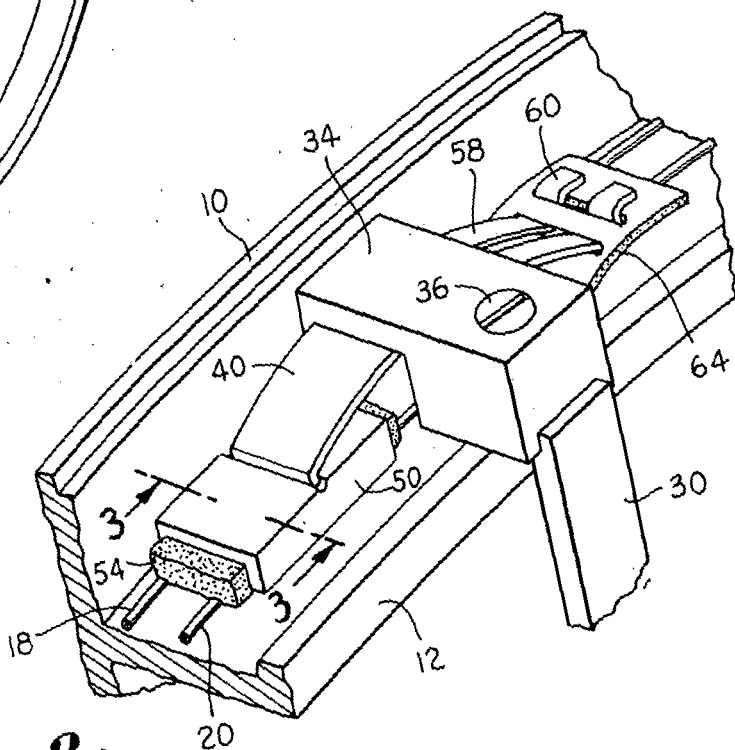
A variable resistance device which includes a cylindrical housing having elongated resistance wires fixed thereto. A movable arm having a supporting block carried on the outer end thereof is rotatably carried by the cylindrical housing. An arcuate steel spring member is pivotally supported by the movable arm. A leather wiper member is carried adjacent one end of the spring steel member, and an electrically conductive surface is carried adjacent the other end. The supporting block maintains the spring steel member in compression so that a constant pressure is applied to the conductive end of the spring steel member and the leather wiper. The leather wiper is saturated with a lubricating oil for maintaining the resistance wire clean as the movable arm is manipulated.

**6 Claims, 9 Drawing Figures**

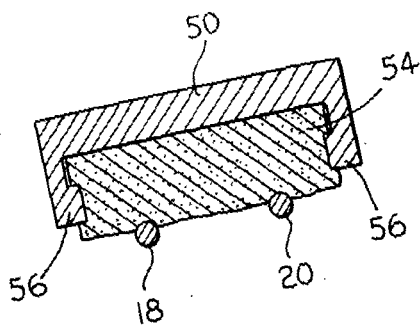




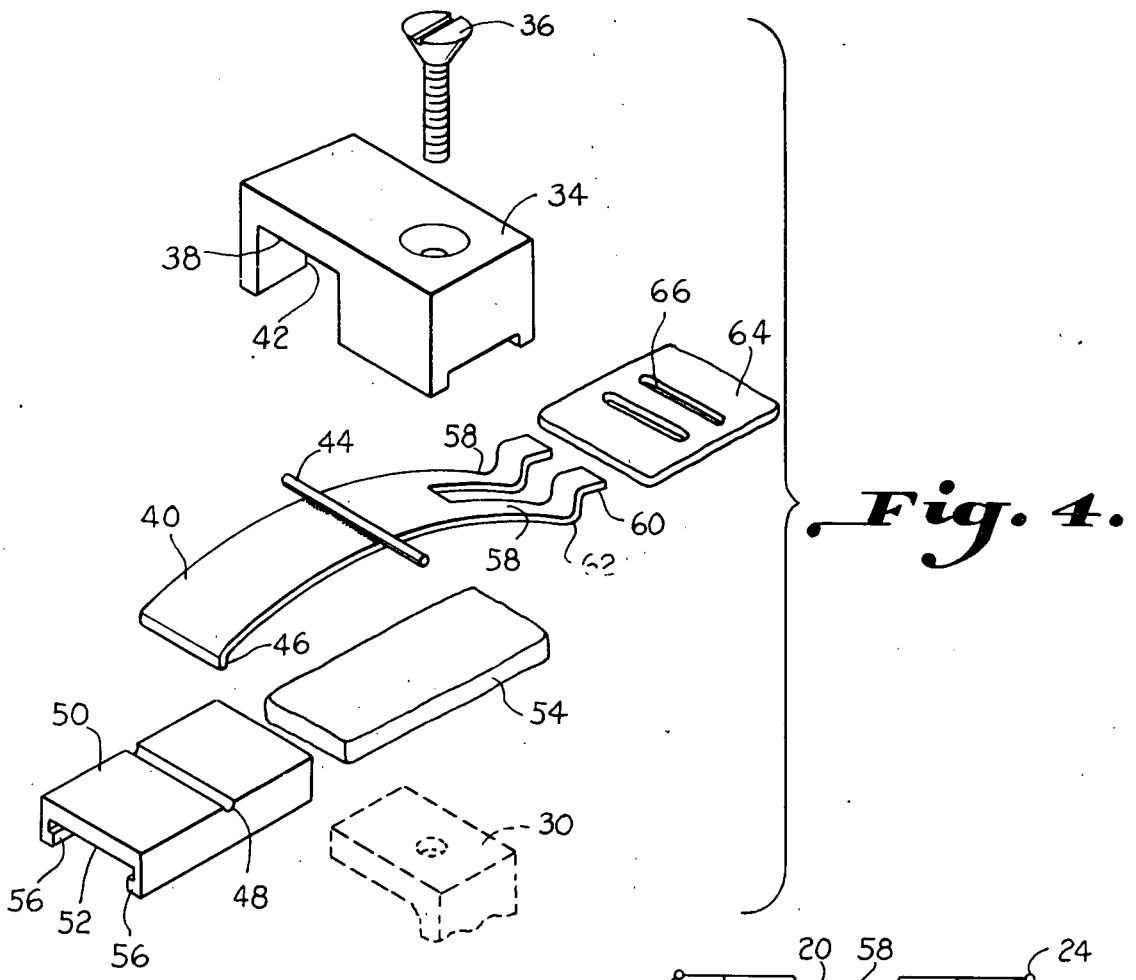
*Fig. 1.*



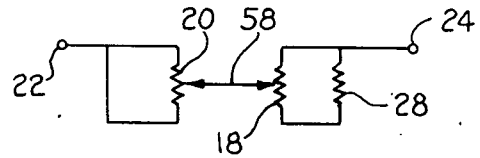
*Fig. 2.*



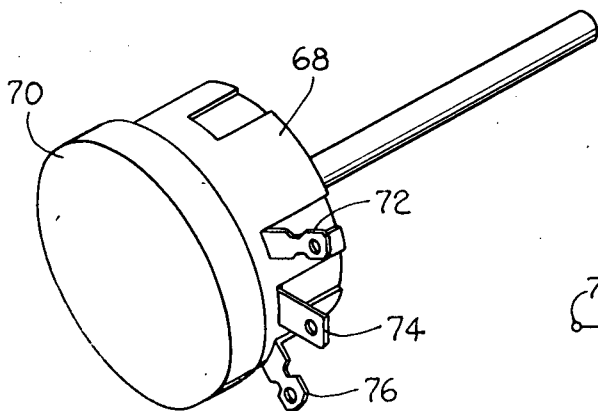
*Fig. 3.*



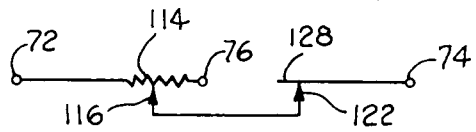
*Fig. 4.*



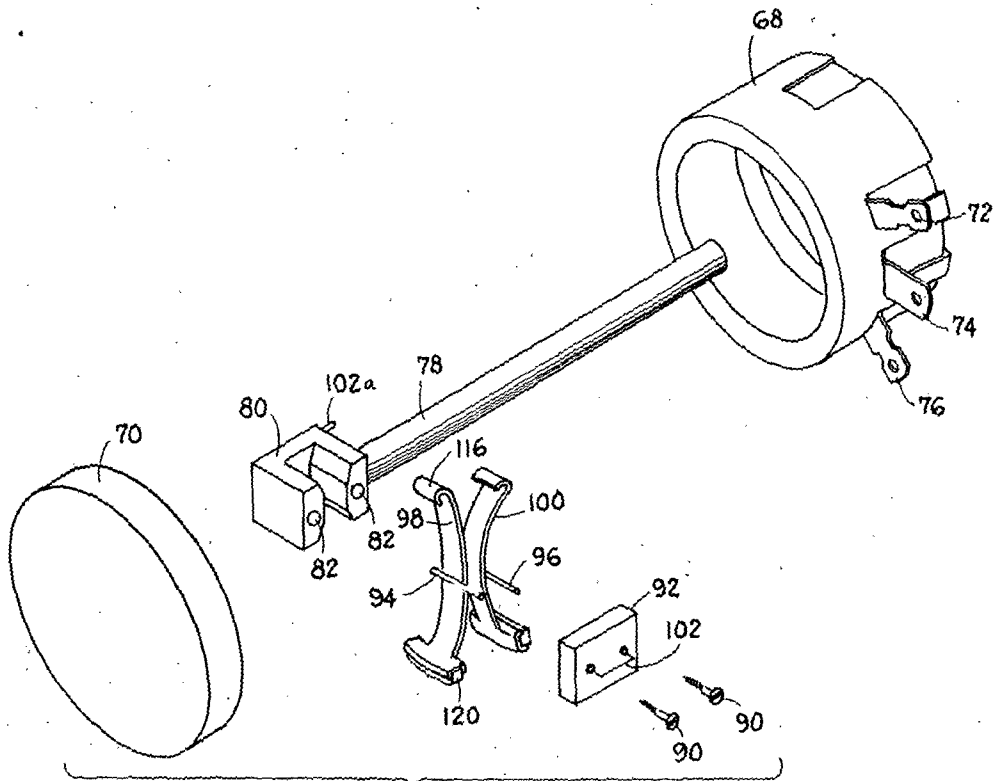
*Fig. 5.*



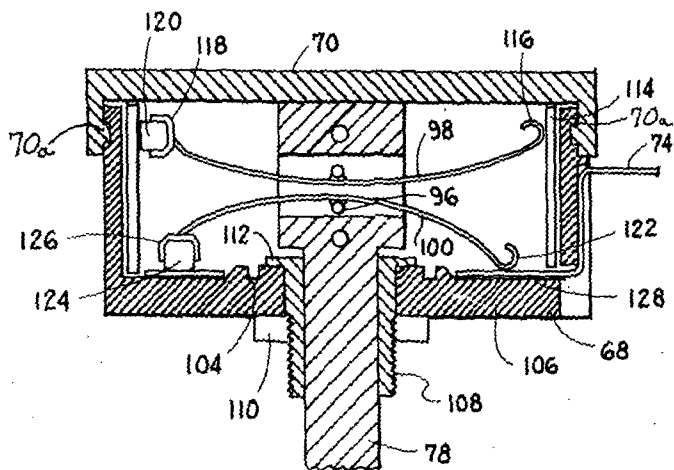
*Fig. 6.*



*Fig. 7.*



*Fig. 8.*



*Fig. 9.*

## VARIABLE RESISTANCE CONSTANT TENSION AND LUBRICATION DEVICE

### ORIGIN OF THE INVENTION

The invention described herein was made in performance of work under a NASA Contract, and is subject to the provisions of Sections 305 of the National Aeronautics Space Act of 1968, Public Law 85-568 (72 Stat. 435, 42 U.S.C. 2457).

### BACKGROUND OF THE INVENTION

This invention relates generally to a variable resistance device, and more particularly to a constant tension and lubricating member which slides along the resistive elements for varying the resistance of the element and maintaining such lubricated and clean.

Strip chart recorders normally incorporate potentiometers which have one or more resistance wires extending around a cylindrical housing. When these wires become contaminated by dirt, corrosion or other similar material, an electronic noise (oscillation of the recorder pin) will occur, and will make track reading of the recorder very difficult.

To minimize this condition, the recorders are frequently disassembled and the potentiometers cleaned and lubricated with a slide wire lubricant. This treatment corrects the problem, however, after a period of time the condition will reoccur. Furthermore, this noise will often appear during a critical period, such as prior to a launch, which could possibly interfere with the entire launching operation of a space vehicle.

### SUMMARY OF THE INVENTION

In order to overcome the problems of the resistance elements of potentiometers, rheostats and the like, becoming coated with dirt or corrosion, a wiper arm is mounted on a movable arm which has a supporting block disposed adjacent the resistant element. An arcuate steel spring member is pivotally attached to the supporting arm and has a leather wiper arm carried adjacent one end in contact with the resistive element. The leather member is saturated with a lubricating and cleaning oil for maintaining the resistance wire clean as the movable arm is manipulated. Positioned adjacent the other end of the steel spring member is a contact surface. This contact surface can be merely an extension of the spring steel member. In one particular embodiment where a pair of resistive wires are utilized in the potentiometer the end of the spring steel member, which includes the contact surface, merely provides a short circuit between the two wires. The manner in which the potentiometers that include resistive wires are electrically connected in circuits may vary, therefore, it will not be described in detail since the important portion of the subject invention is the cleaning action of the leather wiper and the contact arm. The arcuate spring steel member is maintained in compression by the supporting block so that constant tension is applied to both the contact surface and the leather wiper.

Accordingly, it is an important object of the present invention to provide a variable resistance device with a movable arm that has a cleaning element positioned on one end, and a contact surface positioned on the other end.

Still another important object of the present invention is to provide an extremely low maintenance cleaning device for rheostats, potentiometers, and the like, for maintaining the resistance element included therein clean.

Still another important object of the present invention is to provide a contact surface for a variable resistance device which is held in contact with a resistive element included therein by a positive force.

These and other objects and advantages of the invention will become more apparent upon reference to the following specification, attendant claims and drawings.

### BRIEF DESCRIPTION OF THE DRAWINGS

FIG. 1 is a perspective view illustrating a potentiometer provided with a spring steel member having a wiper member adjacent one end, and a contact surface adjacent the other end constructed in accordance with the present invention.

FIG. 2 is an enlarged perspective view illustrating the wiper and contact arm assembly.

FIG. 3 is a cross-sectional view taken along line 3-3 of FIG. 2.

FIG. 4 is an exploded perspective view illustrating the movable arm and wiper arm assembly constructed in accordance with the present invention.

FIG. 5 is an electrical schematic diagram illustrating one particular method that the variable resistance device illustrated in FIG. 1 can be wired.

FIG. 6 is a perspective view of still another modified form of the invention.

FIG. 7 is an electrical schematic diagram of the variable resistance device illustrated in FIG. 6.

FIG. 8 is an enlarged exploded perspective view illustrating the variable resistance device of FIG. 6.

FIG. 9 is a cross-sectional view of the variable resistance device shown in FIGS. 6 and 8.

Referring to FIGS. 1, 2, 3 and 4 of the drawings, there is illustrated a conventional disc-type potentiometer, such as manufactured by Texas Instrument Corp., which has been modified to incorporate a movable contact arm and wiper arm constructed in accordance with the present invention. The potentiometer disclosed therein includes a disc shaped housing 10 having a cylindrical portion 12 extending outwardly therefrom. The cylindrical portion 12 has a gap provided therein, into which a non-conductive block 14 is secured by a screw 16. Extending around the periphery of the cylindrical portion 12 are a pair of parallel resistive wires 18 and 20. The ends of these resistive wires which extend under the block 14 are connected to input and output terminals 22 and 24, such as illustrated in FIG. 5. Connected between the output terminals 24 and 22 is another resistor 28 in parallel with resistive wire 18.

A rotatable arm 30 is suitably journaled on a shaft 32 which is centrally located in the disc-shaped housing 10. Attached to the outer end of the rotatable arm 30 is a pivot block assembly 34 which is constructed of any suitable non-conductive material, such as nylon. The block 34 is attached to the rotatable arm 30 by means of a screw 36.

The block 34 is rectangular in shape and has a square shaped passage 38 extending through the lower portion which is provided for receiving an arcuate spring steel member 40. Positioned in the side walls of the passage

38 are a pair of opposed vertical grooves 42. Only one of the grooves is shown for purposes of clarity. A horizontal pin 44 is secured adjacent the central portion of the spring steel member 40 and is adapted to extend into the grooves 42 provided in the support block 34. This is to permit the spring steel member 40 to pivot about the pin 44.

The spring steel member 40 is arcuate in shape and adjacent one end has a downwardly extending lip 46, which extends into a groove 48 provided in a wiper block assembly 50. The wiper block assembly 50 has a groove 52 adjacent the bottom thereof, into which a leather wiper member 54 extends. Flanges 56 extend inwardly on opposed sides of the groove 52 for holding the leather wiper member 54 in place.

The leather member 54 is saturated with any suitable lubricating oil which, when such is moved across the resistive wires 18 and 20, cleans the dirt and corrosion therefrom.

The other end of the spring steel member 40 has a pair of bifurcated arms 58 which extend downwardly and then terminate in a substantially S-shaped portion 60 adjacent the end thereof. A bottom surface 62 of the bifurcated arms 58 is provided for producing a contact surface with the resistive elements 18 and 20. A second wiper and lubricating pad 64 having a pair of parallel laterally extending slots 66 are slipped over the end of the bifurcated members in the manner shown in FIG. 2. This enables a contact surface 62 of the spring steel member 40 to be in contact with the resistive elements while also permitting the ends of the wiper 64 to engage the resistive wires 18 and 20 for aiding in maintaining such clean.

When the support block 34 is screwed down tightly against the top portion 30 of the movable arm the spring steel member 40 is placed under compression. Such compression causes a constant tension to be applied adjacent each end of the spring steel member 40. This constant tension maintains the leather wipers 54 and 64 in contact with the resistive elements 18 and 20, as well as maintains the contact surface 62 adjacent the other end of the spring steel member 40 in contact with the resistive elements.

The purpose of pivotally attaching the spring steel element 40 by means of the pin 44 to the block is to provide automatic adjustment of the spring steel member when the compression therein tends to vary with age. The upward force applied by means of the wiper block 50 pushing upwardly against the flange 46 of the spring steel member causes the contact surfaces 62 to always be maintained in contact with the resistive elements.

FIG. 5 of the drawings illustrate the bifurcated arms 58 providing a short between the resistive elements 20 and 18. By moving the movable arm 30 the amount of resistance coupled between terminals 22 and 24 can be varied.

FIG. 6 illustrates another conventional resistive potentiometer modified to include an arcuate wiper arm constructed in accordance with the present invention. The potentiometer includes a circular housing 68. The potentiometer is provided with conventional electrical connectors 72, 74 and 76.

The potentiometer includes an elongated shaft 78 which extends through the housing. A U-shaped block 80 is constructed of any suitable non-conductive material, such as plastic. The inner surface of the U-shaped block has holes 82 provided therein for receiving

screws 90 for attaching an end plate 92 thereto. Provided in the U-shaped block 80 and the end plate 92 are a pair of spaced small holes into which pins 94 and 96 carried on the spring steel members 98 and 100 extend. The end plate 92 has a shorting wire 102 which electrically connects the pins 94 and 96 together when the supporting block 80 is assembled. Extending downwardly from the bottom of the U-shaped member 80 is a stop-pin 102a which rides in a groove 104 provided in a base portion 106 of the circular housing 68. An abutment (not shown) is included in the groove 104 for limiting the rotation of the shaft 78. The shaft 78 is journaled within a bearing 108 extending through a hole in the bottom of the housing 106. A washer 110 is threaded on the bushing 108 for cooperating with a flange portion 112 on the bushing to secure the bushing in the base portion 106 of the housing.

A cap 70 is secured to the housing 68 by any suitable means, such as by lock bosses 70a. The cap presses against the top of block 80 placing the spring steel members 98 and 100 under compression. This compression causes a constant tension to be applied adjacent each end of spring steel members 98 and 100.

A circular resistive element 114 extends around the wall of the housing in a conventional manner, and the ends of the resistive element 114 are connected to terminals 72 and 76.

As seen in FIG. 9, the spring steel member 90 is arcuate shaped and has a curved portion 116 adjacent one end which is in contact with the resistive element 114. Adjacent the other end is a U-shaped holder 118 into which a leather wiper 120 is carried. The leather wiper 120 may be secured within the U-shaped member 118 by any suitable means, such as by gluing. It is noted that the leather wiper 120 is diametrically opposed from the curved contact member 116 so that when the shaft 78 is rotated such engages the same circular portion of the resistive element. The lubrication carried on the leather wiper 120 will maintain that circular portion clean so that a positive contact can be provided between the curved portion 116 and the resistive element 114. The arcuate spring steel member 98 is in compression so that a uniform and constant pressure is applied to the contact end 116 and the wiper 120.

As shown in FIG. 8, the ends of pins 94 and 96 are electrically connected together by means of the jumper wire 102. In order to provide a complete circuit the current is allowed to flow through the pin 96 and another arcuate shaped spring steel member 100. Carried on one end of the arcuate shaped spring steel member 100 is a curved contact portion 122. A leather lubricating wiper 124 is carried in a U-shaped member 126 adjacent the other end. The contact member 122 engages a circular plate 128 carried on the base member 106. It is noted that the wiper 124 also engages a similar circular path carried on the circular electrically conductive plate 128 for maintaining such clean. The electrically conductive plate 128 is connected directly to the center output terminal 74. The spring steel member 100 is maintained in compression so as to provide a uniform and positive force adjacent the wiper portion 124 and the contact member 122.

FIG. 7 illustrates schematically the electrical circuit of the potentiometer illustrated in FIGS. 6, 8 and 9. As can be seen, electrical terminal 72 is connected directly to one side of the resistive element 114, and the other side is connected to terminal 76. The contact portion

116 of the spring steel member 98 engages a resistive element and is electrically connected to the contact end 122 of the spring steel member 100. The electrical conductive plate 128 is, in turn, connected to the terminal 74. This rheostat may be wired into various circuits and in various different configurations.

While a preferred embodiment of the invention has been described using specific terms, such description is for illustrative purposes only, and it is to be understood that changes and variations may be made without departing from the spirit or scope of the following claims:

What is claimed is:

1. A variable resistance device comprising:

- A. a cylindrical housing,
- B. an elongated resistance wire fixed to said cylindrical housing,
- C. a movable arm having a supporting block disposed adjacent said resistance wire,
- D. an arcuate spring steel member,
- E. pivot means carried adjacent a central portion of said arcuate spring steel member engaging said supporting block,
- F. a leather wiper member carried adjacent one end of said arcuate spring steel member engaging said resistance wire for aiding in maintaining said resistance wire clean as said movable arm is shifted,
- G. another end of said spring steel member being in contact with said resistance wire so that a balanced tension is maintained on said end of said arcuate spring steel member about said pivot means.

2. The variable resistance device as set forth in claim 1, further comprising:

- A. A second elongated resistance wire spaced from and parallel to said other elongated resistance wire, and
- B. said other end of said spring steel member providing a short circuit between said elongated resistance wires.

3. The variable resistance device as set forth in claim 1 wherein:

- A. said supporting block presses against said spring steel member placing said spring steel member under compression so that said leather wiper and said another end of said spring steel member are held under pressure against said resistance wire.

4. The variable resistance device as set forth in claim 1 further comprising:

- A. a lubricating oil carried by said leather wiper for aiding in maintaining said resistive wire clean.

5. In combination with a variable resistance device having a cylindrical housing with an elongated resistive element carried by said cylindrical housing, a contact arm comprising:

- A. an elongated arcuate spring steel member,
- B. a rotatable support member centrally located within said housing,
- C. pin means carried adjacent a central portion of said elongated arcuate spring steel member engaging said support member for connecting said central portion of said spring steel member to said rotatable support member,
- D. a leather wiper carried adjacent one end of said spring steel member engaging said resistive element,
- E. an electrically conductive surface carried adjacent the other end of said spring steel member, engaging said resistive member, and
- F. said support member applying a force to a central portion of said spring steel member for placing said spring steel member under compression so that said wiper and conductive surface are maintained in positive contact with said resistive element.

6. The variable resistance device as set forth in claim 5 wherein said contact arm further includes:

- A. a pivotal connection between said spring steel member and said support member.

\* \* \* \* \*

40

45

50

55

60

65