

# NASA TECH BRIEF

## NASA Pasadena Office



NASA Tech Briefs announce new technology derived from the U.S. space program. They are issued to encourage commercial application. Tech Briefs are available on a subscription basis from the National Technical Information Service, Springfield, Virginia 22151. Requests for individual copies or questions relating to the Tech Brief program may be directed to the Technology Utilization Office, NASA, Code KT, Washington, D.C. 20546.

### Laser-Excited Fluorescence for Measuring Atmospheric Pollution

A new system for measuring the amount of a given pollutant at a specific location, such as in a smokestack plume, is shown in the illustration. An infrared laser aimed at the plume has a wavelength ( $\lambda_0$ ) that will cause a particular molecule (e.g., NO, NO<sub>2</sub>, CO, CO<sub>2</sub>, SO<sub>2</sub>, or O<sub>3</sub>) to fluoresce. The remainder of the system is a sensitive detector that can separate the fluorescence signal from other radiation and measure its intensity to give an indication of the concentration of the pollutant.

The filter in the detector absorbs all radiation at  $\lambda_0$ ; the remaining radiation passes through a cell with two compartments: One contains the pollutant of interest, and the other a noninterfering gas such as N<sub>2</sub> or He. The cell containing the pollutant will absorb any fluoresced radiation from the plume. The difference in the intensity of radiation leaving the two cell halves is equal to the intensity of the fluorescence signal from the pollutant. This signal is proportional to the pollutant concentration in the plume.

A rectangular chopper rotates to alternately block the radiation from the cell halves. This radiation is focused onto a photodetector difference circuit. The period of the chopper is some multiple of the laser-pulse frequency. Thus, the output of the difference circuit will be a triangular (because of the chopper shape) envelope of voltage pulses (peak-to-peak height  $\Delta V$ ) at the laser-pulse frequency. This signal is amplified and integrated in a boxcar integrator that is synchronized with the laser-pulse frequency.

The integrator output is a triangular waveform with a peak-to-peak voltage proportional to  $\Delta V$ . This signal goes through a tuned amplifier, is synchronously demodulated, and is integrated. The integrator output is a dc voltage proportional to  $\Delta V$ . Since  $\Delta V$  depends on the amount of pollutant present in the plume, the dc signal can operate a recorder which will show how the plume concentration of the molecule of interest changes over time.

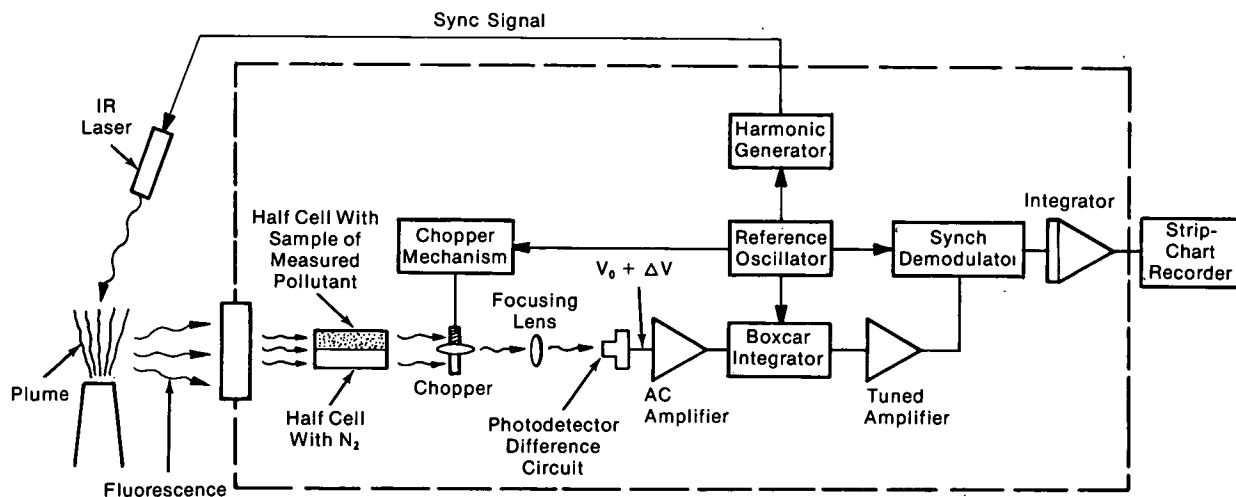

System for Detecting Fluorescence From a Distant Source

(continued overleaf)

**Note:**

Requests for further information may be directed to:

Technology Utilization Officer  
NASA Pasadena Office  
4800 Oak Grove Drive  
Pasadena, California 91103  
Reference: TSP75-10275

**Patent status:**

This invention has been patented by NASA (U.S. Patent No. 3,891,848). Inquiries concerning non-exclusive or exclusive license for its commercial development should be addressed to:

Patent Counsel  
NASA Pasadena Office  
4800 Oak Grove Drive  
Pasadena, California 91103

Source: Robert T. Menzies of  
Caltech/JPL  
(NPO-13231)