

# NASA TECH BRIEF

## NASA Pasadena Office



NASA Tech Briefs announce new technology derived from the U.S. space program. They are issued to encourage commercial application. Tech Briefs are available on a subscription basis from the National Technical Information Service, Springfield, Virginia 22151. Requests for individual copies or questions relating to the Tech Brief program may be directed to the Technology Utilization Office, NASA, Code KT, Washington, D.C. 20546.

### Processing for Obtaining Good Quality Water From Sewage

#### The problem:

Commonly-used biological sewage treatment methods are inefficient and are unable to meet the increasing purification requirements. They require large land areas and emit unpleasant odors. The resulting large quantities of solid and liquid effluents are health hazards and are difficult and expensive to dispose.

#### The solution:

A more-efficient sewage treatment method incorporates an aqueous slurry of activated carbon and ash. The process eliminates the smell and greatly reduces the amounts of solids requiring disposal. The solids consist only of sterile ash.

#### How it's done:

One of the main features of the new process is the pyrolysis of primary sewage solids to produce an activated carbon and ash. These are then used to purify the sewage. The process consists of four major steps, as shown in the illustration, all of which operate continuously.

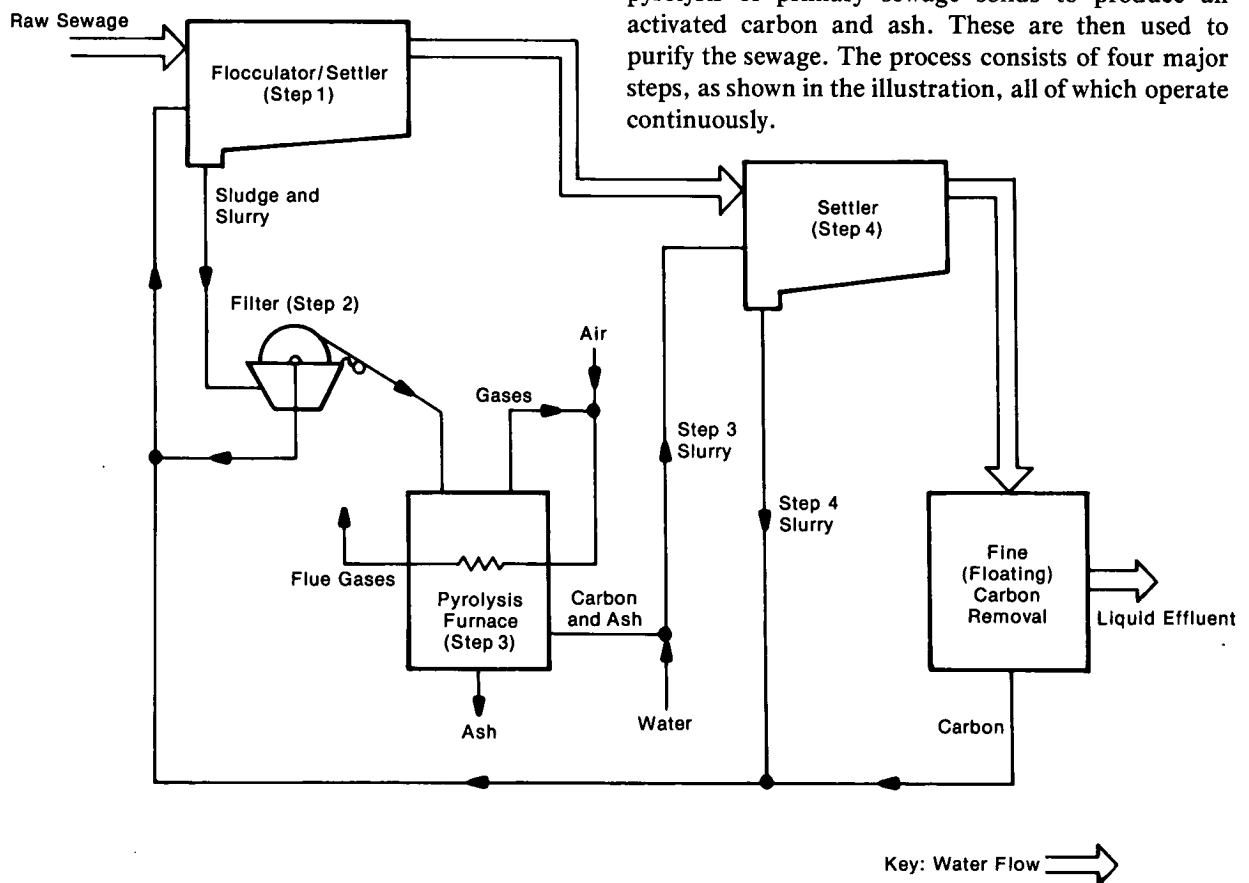

Sewage Treatment Process

(continued overleaf)

In step 1, an aqueous slurry of finely-divided activated carbon and ash (such as is produced in step 4 below) is added to incoming raw sewage. The slurry flocculates and settles the solids in the sewage to a mixture of sewage sludge and carbon more rapidly and more completely than in any existing process. Much of the liquid waste is absorbed by the carbon and ash and the need for conventional biological pretreatment is eliminated. The mixture is drawn off and processed as in step 2 below. The liquid effluent will be reprocessed in step 4.

In step 2, the mixture from step 1 is dried (by filtration, centrifugation, or a similar process) faster and more completely than in other processes and without the addition of any chemical agent. The solid from step 2 is pyrolyzed (step 3) to combustible gases, sterile ash, and an aggregate of activated carbon and ash. The gases are combustible and can maintain the pyrolysis without the addition of external heat. The aggregate is added to water to form a slurry. This slurry is mixed with the liquid effluent from step 1 to further remove dissolved impurities and is allowed to settle in step 4.

The settled carbon and ash are then drawn off as a slurry and used again in step 1. The water effluent from step 4 is equal to or better in quality than that from currently-used biological sewage treatment processes.

**Note:**

Requests for further information may be directed to:

Technology Utilization Officer  
NASA Pasadena Office  
4800 Oak Grove Drive  
Pasadena, California 91103  
Reference: TSP75-10113

**Patent status:**

This invention is owned by NASA, and a patent application has been filed. Inquiries concerning non-exclusive or exclusive license for its commercial development should be addressed to:

Patent Counsel  
NASA Pasadena Office  
4800 Oak Grove Drive  
Pasadena, California 91103

Source: Marshall F. Humphrey of  
Caltech/JPL  
under contract to  
NASA Pasadena Office  
(NPO-13224)