



NATIONAL AERONAUTICS AND SPACE ADMINISTRATION
WASHINGTON, D.C. 20546

SEP 16 1974

REPLY TO
ATTN OF: GP

TO: KSI/Scientific & Technical Information Division
Attn: Miss Winnie M. Morgan

FROM: GP/Office of Assistant General
Counsel for Patent Matters

SUBJECT: Announcement of NASA-Owned U.S. Patents in STAR

In accordance with the procedures agreed upon by Code GP and Code KSI, the attached NASA-owned U.S. Patent is being forwarded for abstracting and announcement in NASA STAR.

The following information is provided:

U.S. Patent No. : 3,830,060

Government or Corporate Employee : U.S. Government

Supplementary Corporate Source (if applicable) : [Signature]

NASA Patent Case No. : ARC-10,461-1

NOTE - If this patent covers an invention made by a corporate employee of a NASA Contractor, the following is applicable:

YES NO

Pursuant to Section 305(a) of the National Aeronautics and Space Act, the name of the Administrator of NASA appears on the first page of the patent; however, the name of the actual inventor (author) appears at the heading of column No. 1 of the Specification, following the words "...with respect to an invention of ..."

Bonnie L. Woerner
Bonnie L. Woerner
Enclosure

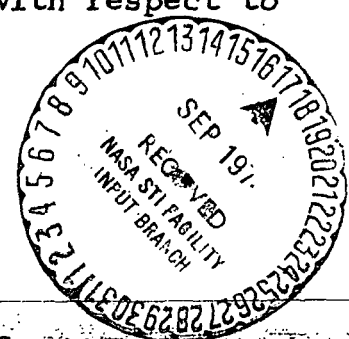

N74-33379
Unclas 48152
00/33
CSSL 20M
(NASA-Case-ARC-10461-1) SOLID MEDIUM
THERMAL ENGINE Patent (NASA) : 25 P

[54] **SOLID MEDIUM THERMAL ENGINE**

[75] Inventors: **James R. Jedlicka**, Saratoga; **Le Roy R. Guist**, Campbell; **Richard M. Beam**, Santa Clara, all of Calif.

Primary Examiner—Edgar W. Geoghegan
Assistant Examiner—H. Burks, Sr.
Attorney, Agent, or Firm—Darrell G. Brekke; Armand G. Morin, Sr.; John R. Manning

[73] Assignee: **The United States of America as represented by the Administrator of the National Aeronautics and Space Administration**, Washington, D.C.

[22] Filed: **Feb. 27, 1973**

[21] Appl. No.: **336,319**

[52] U.S. Cl. **60/527**

[51] Int. Cl. **F03g 7/06**

[58] Field of Search **60/23, 26**

[57] **ABSTRACT**

A thermal engine apparatus including an elongated cylindrical tube of metal providing a single phase working substance supported to rotate freely about its longitudinal axis while being subjected to continuous bending moment producing stress loads applied intermediate its ends wherein the bending moment causes portions of the tube to alternately pass through states of compression and tension as the tube rotates about its axis. The apparatus further includes structure for positioning the cylindrical tube relative to a source of radiant energy such that the radiant energy strikes that portion of the tube surface which is under compression, transfers thermal energy thereto, and the consequent expansion creates an unbalance of internal forces which causes the body to rotate about its axis.

[56] **References Cited**

UNITED STATES PATENTS

182,172	9/1876	Crookes.....	60/26
3,121,265	2/1964	Hoh.....	60/26
3,665,705	5/1972	Christensen.....	60/23

FOREIGN PATENTS OR APPLICATIONS

307,596	3/1929	Great Britain.....	60/26
---------	--------	--------------------	-------

12 Claims, 8 Drawing Figures

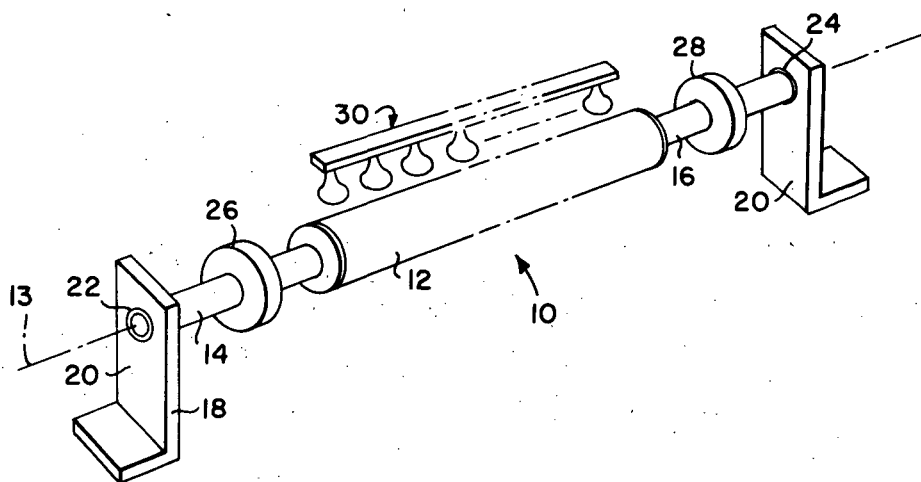

FIG. 1

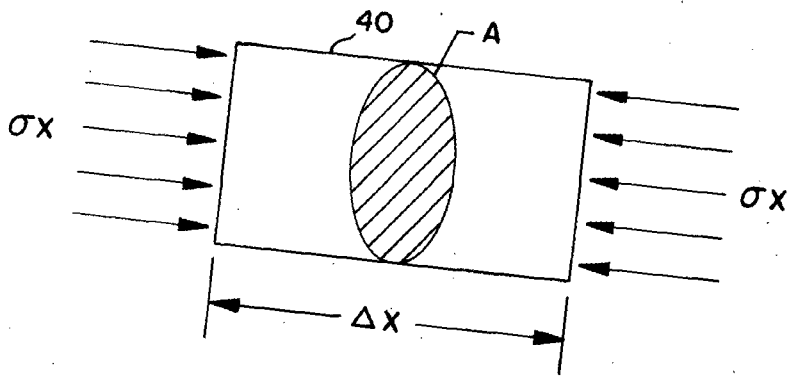
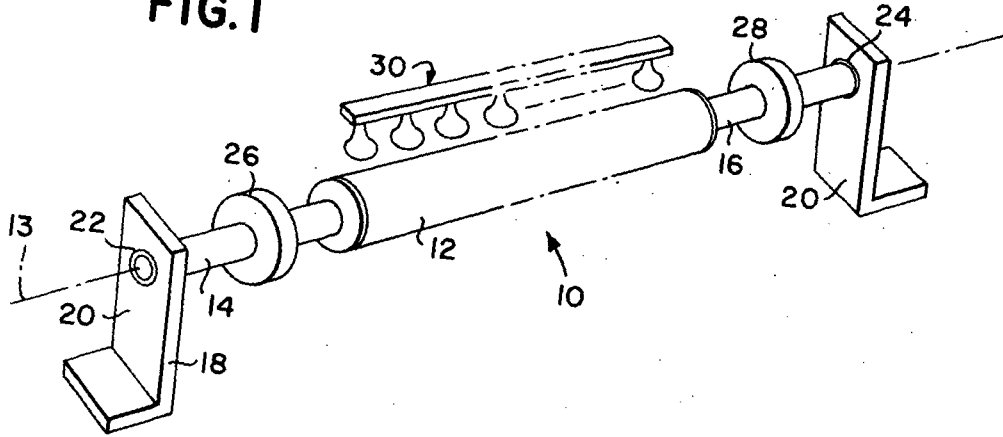

FIG. 2

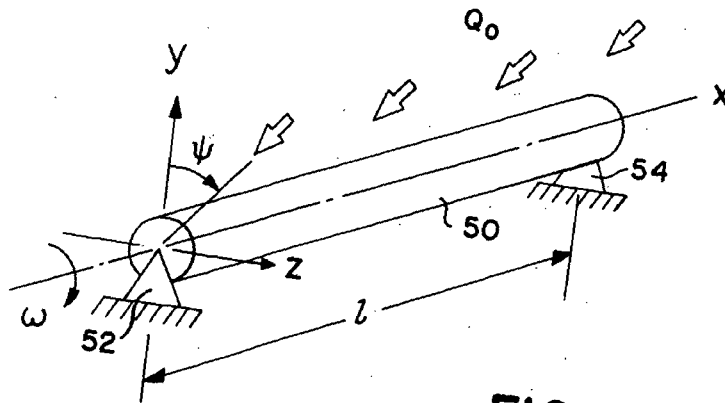

FIG. 3

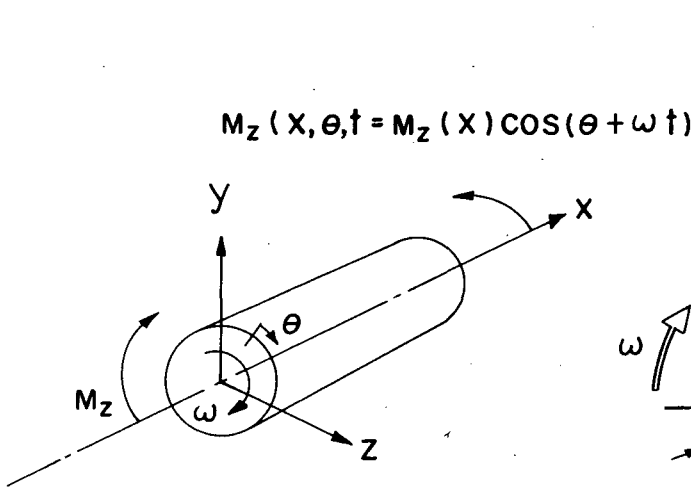

FIG. 5

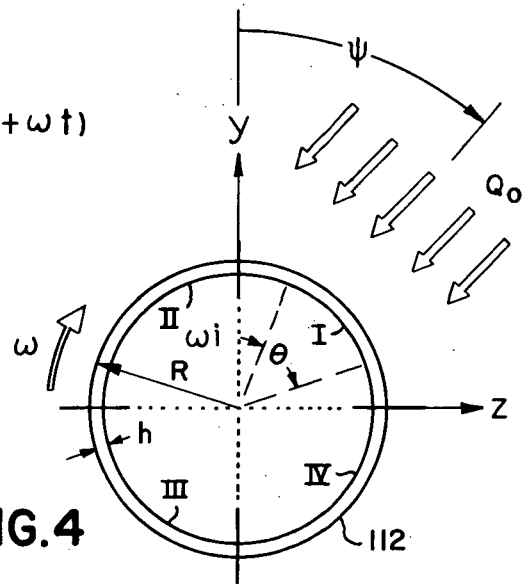

FIG. 4

$Q_0 = 5.6 \text{ kW/m}^2$ (4 SOLAR CONSTANTS)
 $\sigma_{\text{max}} = 83 \text{ MN/m}^2$ (12000 #/in²)

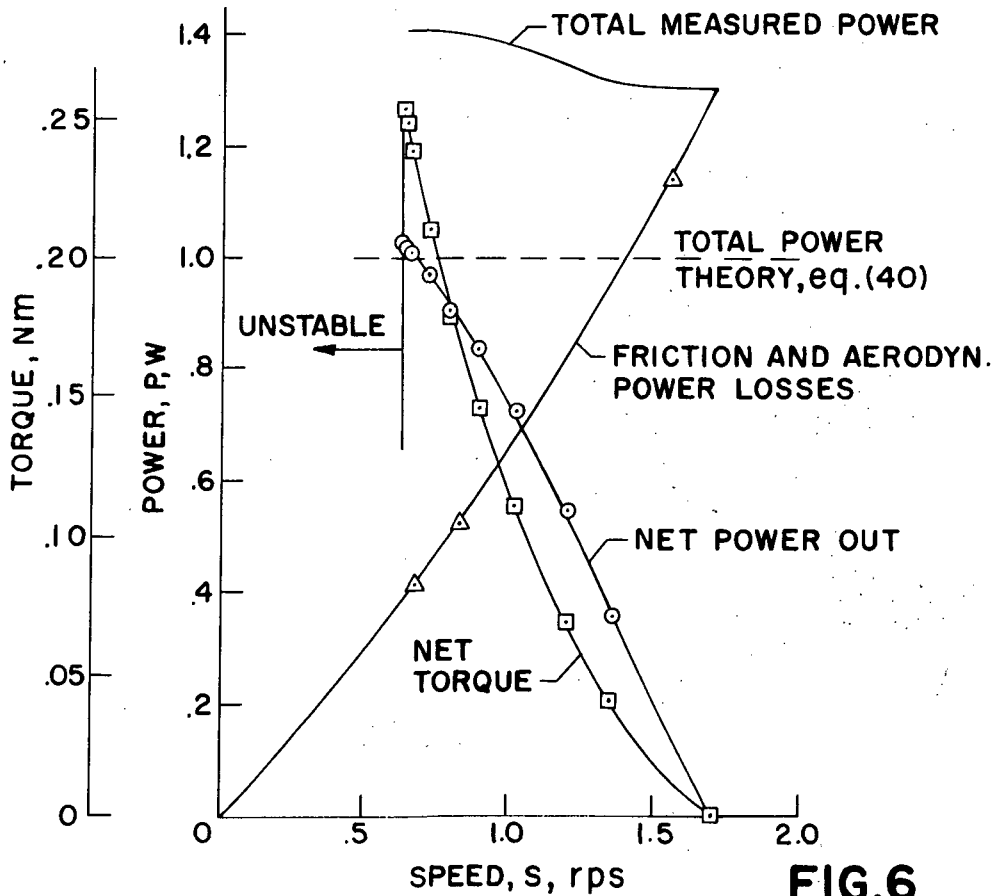
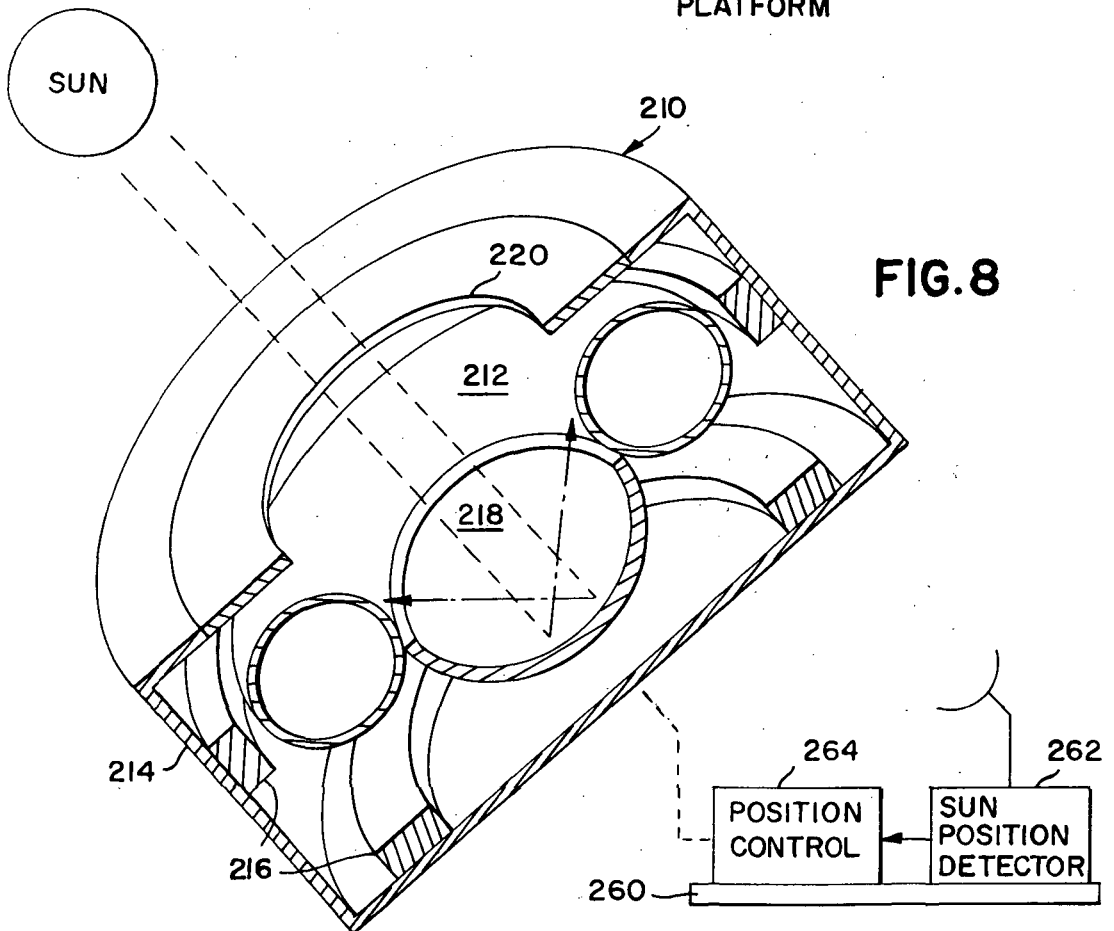
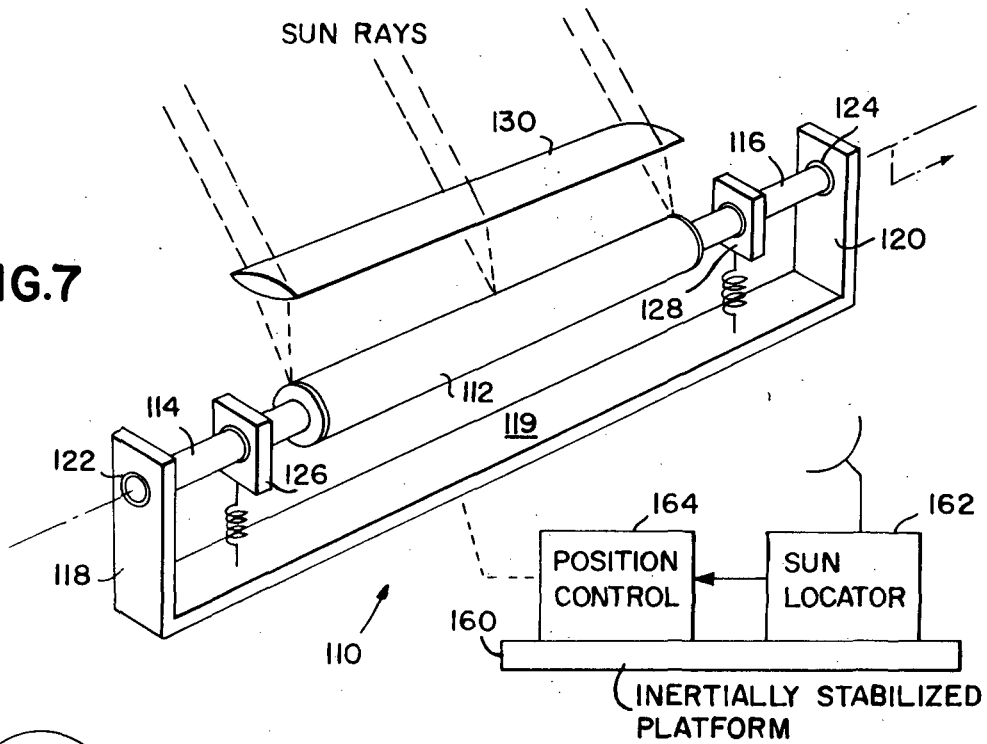

FIG. 6

FIG. 7



SOLID MEDIUM THERMAL ENGINE

The invention described herein was made by employees of the United States Government and may be manufactured and used by or for the government for government purposes without the payment of any royalties thereon or therefor.

BACKGROUND OF THE INVENTION

The invention generally relates to thermal engine apparatus and more particularly to thermal engines using a single phase metallic working substance to convert thermal energy directly into mechanical energy.

DESCRIPTION OF THE PRIOR ART

Thermal engines operating pursuant to the principles of thermal expansion of metals have been proposed in the past. For example, structures such as that shown in the U.S. Pat. to Taylor No. 3,316,415 rely on the use of bi-metallic strips moving on rollers to convert heat induced metallic expansion into a resultant body motion. Other structures such as that disclosed in the U.S. Pat. to Donatelli, et al., No. 3,495,406 rely on laser beam energy or the like to exert direct physical force upon a rotary member to cause the member to rotate. A still further structure described in the U.S. Pat. to Adams, No. 3,430,441, provides an engine for converting heat energy to mechanical energy by thermal expansion and contraction of bi-metallic elements which are passed through heating and cooling zones established within an engine housing.

The direct conversion of heat energy into mechanical energy through the thermal expansion properties of solids has been utilized for control and measurement functions as illustrated by the U.S. Pat. Nos. to Lord, 3,213,284, and McCusker, 3,213,285 relating to heliotropic orientation mechanisms. The U.S. Pat. to Schalkowsky, No. 3,348,374, refers to a sun referenced orientation device in which solar energy is directly converted to mechanical forces for orientating space vehicles relative to the position of the sun. Although these and numerous other approaches have been proposed and utilized to provide thermally driven motive power sources, most prior art devices have been so mechanically complicated or grossly inefficient as to be impracticable.

SUMMARY OF THE PRESENT INVENTION

It is therefore a principal object of the present invention to provide a thermal engine which is mechanically simple and operationally feasible for certain applications.

Briefly, a preferred embodiment of the present invention includes a single phase working substance in the form of a generally cylindrical metallic tube supported such that it is free to rotate about its axis while being subjected to continuous bending moment stressing the body along its longitudinal axis of rotation. The stressing causes certain portions of the tube to be subjected to compression while other portions are under tension as the tube is caused to rotate about its axis. Means are provided for positioning the tube such that radiant energy from a remote source is concentrated on that portion of the cylindrical tube which is under maximum compression with the result being that heat absorbed by this portion causes an imbalance of internal forces

which tend to impart a rotational moment to the tube so that it rotates about its axis.

Among the primary advantages of the present invention are its simplicity of operative mechanical structure and its ability to function in a gravity free environment.

These and other objects and advantages will no doubt become apparent to those of ordinary skill in the art after having read the following detailed description of the preferred embodiments illustrated in the several figures in the drawings.

IN THE DRAWINGS

FIG. 1 is a perspective view schematically illustrating a thermal engine apparatus in accordance with the present invention;

FIGS. 2-5 are schematic diagrams to aid in describing the operation of the present invention;

FIG. 6 is a diagram illustrating measured operational characteristics of one embodiment of the present invention;

FIG. 7 is a perspective diagram schematically illustrating an alternative embodiment of the present invention for use in a gravity-free environment;

FIG. 8 is a diagram schematically illustrating still another alternative embodiment of the present invention.

DETAILED DESCRIPTION OF THE PREFERRED EMBODIMENT

Referring now to the drawings, a simplified embodiment of a thermal engine 10 is shown in FIG. 1 which operates to convert thermal energy directly into rotational kinetic or mechanical energy in accordance with the present invention. Engine 10 includes a thin walled cylindrical tube 12 formed of a suitable metal to provide a single phase solid working body. The exterior surface of tube 12 is coated with a thin layer of flat black paint or the like to increase the absorptivity and emissivity of the body. Cylindrical extension shafts 14 and 16 are fixed to opposite ends of tube 12 and mate with a pair of support columns 18 and 20. Shafts 14 and 16 are disposed coaxial with tube 12 and are journaled to columns 18 and 20 by means of support bearings 22 and 24 respectively.

External loading masses in the form of annular weights 26 and 28 are coaxially mounted upon the shafts 14 and 16 respectively, at selectable distances from the columns 18 and 20. The weights 26 and 28 establish uniform longitudinal bending moments which continuously stress tube 12 so that its uppermost longitudinal portion is subjected to compression and its lower most longitudinal portion is subjected to tension. Bearings 22 and 24 permit the balanced mass comprised of tube 12, shafts 14 and 16 and weights 26 and 28 to rotate freely about the common axis 13. Since the stressing forces applied by weights 26 and 28 are fixed in direction due to gravitational forces, the bending stresses within tube 12 remain positionally fixed independent of the bodies rotation. Thus, with tube 12 stationary or in rotation, the topside longitudinal portion (illustrated as the upper quarter sections I and II in FIG. 4) is always under compression relative to the bottomside longitudinal portion (illustrated as the lower quarter sections III and IV in FIG. 4) and the bottomside portion is always under tension relative to the topside portion.

As suggested by the drawing, tube 12 is positioned in alignment with a source of heat radiation illustrated in the form of a bank of lamps 30 disposed such that the heat rays generated thereby are focused upon at least part of that portion of tube 12 which is under compression. The thermal flux intensity may be controlled by changing the distance between the bank of lamps 30 and tube 12. The lamps are positioned slightly off the vertical plane (by about 5°) so that the engine will be self-starting. No heat is applied to the bottomside of tube 12 and preferably, conditions are such that heat is readily removed therefrom by radiation or convection.

As the temperature of the upper portion of tube 12 is increased due to the incident radiation, the metal in that portion will tend to expand and disrupt the balanced equilibrium conditions with the result being that a torque is developed within tube 12 which causes the tube to revolve about its axis 13.

Referring now to FIGS. 2-6 a more detailed analysis will be given to explain the operating mechanisms of the present invention.

If an element 40 of a solid such as illustrated in FIG. 2 is first loaded externally to produce a stress distribution σ_x on its opposite surfaces and then heated to produce a temperature increase ΔY , the work $\Delta\omega$ done on the external loading due to the temperature increase is

$$\Delta W = \sigma_x A \alpha \Delta T \Delta x \quad (1)$$

where A is the cross-sectional area of the element, Δx the length of the element, and ω the coefficient of thermal expansion of the solid. Equation (1) is based on the uncoupled theory of thermoelasticity which assumes that temperature is independent of strain. The work rate or power (P_o) is then

$$P_o = \Delta W / \Delta t = \sigma_x A x (\Delta T / \Delta t) \Delta x \quad (2)$$

The rate of change of temperature with respect to time t is related to the thermal power P_i into the element so that

$$P_i = \rho c A \Delta x (\Delta T / \Delta t) \quad (3)$$

where ρ and c are the density and specific heat of the solid. If the thermal efficiency of the process is denoted by e_T , then from equations (2) and (3)

$$e_T = P_o / P_i = \sigma_x \alpha / \rho c \text{ (unidirectional stress)} \quad (4)$$

If the applied stresses σ_x are reversed in direction during the cooling portion of a cycle, the thermal efficiency for the complete heating and cooling cycle is

$$e_T = P_o / P_i = 2\sigma_x \alpha / \rho c \text{ (bidirectional stress)} \quad (5)$$

If the element is placed under triaxial stress instead of uniaxial stress, the thermal efficiency is increased threefold to

$$e_T = 6\sigma_x \alpha / \rho c \text{ (triaxial, bidirectional stress)} \quad (6)$$

5 For a system utilizing the solid phase cycle and nonregenerative heating, equations (4), (5), and (6) represent the maximum thermal efficiencies that can be attained.

As described above a simple design of a solid phase engine which utilizes uniaxially stressed material consists of a tube, such as that shown in at 12 in FIG. 1 and schematically illustrated at 50 in FIG. 3, that is free to rotate but has an applied moment fixed in the inertial reference frame. The inertial coordinate system is defined as xyz . The tube 50 is free to rotate about the x -axis and no moment can be carried by the end supports 52 and 54 (pinned ends). The applied moment vector, $M_z(x)$ identified in FIG. 4, is assumed to remain parallel to the z axis. The moment may be due to the weight of the cylinder or applied loading. The thermal loading is provided by a planar flux field of radiant energy with magnitude Q_o which acts normal to the x -axis and at an angle Ψ with the y -axis (FIGS. 3 and 5).

10 If θ is the circumferential coordinate measured from a reference point fixed to the tube 50 (FIG. 5) and R and h are the radius and wall thickness of the tube 50, the differential power produced by an element of the tube is from equation (2),

$$dP_o = \sigma_x(x, \theta, t) h R d\theta \alpha (\delta T(\theta, t) / \delta t) dx \quad (7)$$

and the total power produced by the engine is obtained by integrating expression (7) over the whole tube 50:

$$P_o = \alpha h R \int_0^1 \int_0^{2\pi} \sigma_x(x, \theta, t) (\delta T(\theta, t) / \delta t) d\theta dx \quad (8)$$

40 If the tube is rotating at constant angular velocity ω , the stress is related to the moment from simple beam theory where for $R \gg h$:

$$\sigma_x(x, \theta, t) = [M_z(x) \cos(\theta + \omega t)] / \pi R^2 h \quad (9)$$

To complete the computation of the power output from equation (8), it is necessary to evaluate the temperature distribution in the tube 50. The heat balance equation for a ring element of the tube of unit length in the x direction is

$$kh\delta^2 T(\theta, t) / R^2 \delta \theta^2 - \rho ch \delta T(\theta, t) / \delta t = \xi \epsilon T^4(\theta, t) - \gamma(\theta, t) \quad (10)$$

where k is the material thermal conductivity, ξ the Stefan-Boltzmann constant, and ϵ the thermal emissivity of the tube surface. The following basic assumptions have been made to obtain equation (10):

- The heat loss from the tube is by radiation;
- There is no thermal conduction in the longitudinal (x) direction and $T(\theta, t)$ is the average temperature through the thickness; and
- γ is the total flux distribution into the tube.

For a large class of engines and operating conditions the variation in temperature (denoted $\bar{T}(\theta, t)$ around

the circumference will be small compared to the average temperature (T_A) of the tube, that is,

$$T(\theta, t) = T_A + \bar{T}(\theta, t) \quad |\bar{T}(\theta, t)| \ll T_A$$

(11) 5

If condition (11) is introduced into the heat balance equation (10) and only first-order terms retained, one obtains

$$kh\delta^2\bar{T}(\theta, t)/R^2\delta\theta^2 - \rho ch\delta\bar{T}(\theta, t)/\delta t - 4\xi\epsilon T_A^3\bar{T}(\theta, t) = \xi\epsilon T_A^4 - \gamma(\theta, t)$$

(12) 15

If the thermal absorptivity of the tube's surface is α_T and the tube is rotating with constant angular velocity ω , the function $\gamma(\theta, t)$ becomes

$$\gamma(\theta, t) = \alpha_T Q_o g(\theta + \omega t - \psi)$$

(13) 20

where g is a functional relationship. Expressed as a Fourier series representation,

$$\gamma(\theta, t) = \alpha_T Q_o \sum_{n=0}^{\infty} a_n \cos n(\theta + \omega t - \psi)$$

(14) 25

The "steady state" or particular solution for equation (12) with γ defined by equation (14) can be written

$$\bar{T}(\theta, t) = \sum_{n=1}^{\infty} \bar{T}_n(\theta, t)$$

(15) 30

where $\bar{T}_n(\theta, t)$ is the solution to the equation

$$kh\delta^2\bar{T}_n(\theta, t)/R^2\delta\theta^2 - \rho ch\delta\bar{T}_n(\theta, t)/\delta t - 4\xi\epsilon T_A^3\bar{T}_n(\theta, t) = -\alpha_T Q_o a_n \cos n(\theta + \omega t - \psi)$$

(16) 35

For all $n < 0$;

$$a_o = \xi\epsilon T_A^4 / \alpha_T Q_o$$

since T_A has been assumed time independent. A particular solution to equation (16) can be easily obtained in the form

$$\bar{T}_n(\theta, t) = \bar{T}_n(\theta + \omega t - \psi) = \bar{T}_n(\eta)$$

(17) 40

Equation (16) becomes

$$kh\bar{T}_n''(\eta)/R^2 - \rho ch\omega\bar{T}_n'(\eta) - 4\xi\epsilon T_A^3\bar{T}_n(\eta) = -\alpha_T Q_o a_n \cos n\eta$$

(18) 45

where a prime is used to denote differentiation with respect to η .

A particular solution to equation (18) is

$$\bar{T}_n(\eta) = -\{R^2\alpha_T Q_o a_n \cos[n\eta - \arctan pn/(q - n^2)]\} / khpn[1 + (q - n^2)/(pn)^2]^{1/2}$$

(19)

where p is the negative reciprocal of the Fourier modulus

$$p = -\rho c \omega R^2 / k$$

10

(20)

and

$$q = -4\xi\epsilon T_A^3 R^2 / kh$$

(21)

With the notation

$$A_n = R^2\alpha_T Q_o a_n / khpn[1 + (q - n^2)/(pn)^2]^{1/2}$$

20

(22)

$$\Phi_n = \arctan pn/(q - n^2), \quad -(\pi/2) < \Phi_n \leq (\pi/2)$$

25

(23)

the solution to the heat balance equation (12) with thermal input γ defined by equation (14) can be written

$$T(\theta, t) = T_A - \sum_{n=1}^{\infty} A_n \cos [n(\theta + \omega t - \psi) - \Phi_n]$$

(24)

35

and

$$\partial T(\theta, t) / \partial t = \sum_{n=1}^{\infty} n\omega A_n \sin [n(\theta + \omega t - \psi) - \Phi_n]$$

(25)

The output power of the engine [equation (8)] may now be computed with expressions (9) and (25) as

$$P_o = [\alpha/\pi R] \int_0^1 M_s(x) dx \int_0^{2\pi} \cos(\theta + \omega t) \sum_{n=1}^{\infty} n\omega A_n \sin [n(\theta + \omega t - \psi) - \Phi_n] d\theta$$

(26)

However, this can be reduced to

$$P_o = [\alpha\omega/R] \sin(-\psi - \Phi_1) A_1 \int_0^1 M_s(x) dx$$

(27)

Introduction of A_1 from equation (22) into the power equation produces

$$P_o = \left[R\alpha\omega\alpha_T Q_o a_1 \sin(-\psi - \Phi_1) \int_0^1 M_s(x) dx \right] / khp[1 + (q - 1)^2/p^2]^{1/2}$$

(28)

If the radiant heat absorbed by an element is assumed to be proportional to the cosine of the angle between the normal to the surface and the thermal radiation di-

rection (Lambert's law), then the function g , required in equation (13), becomes

$$g(\theta + \omega t - \psi) = 0$$

$$= \cos(\theta + \omega t - \psi) \quad 1\pi \leq (\theta + \omega t - \psi) \leq -\pi/2$$

$$= 0 \quad G21\pi/2 \leq (\theta - \omega t + \psi) \leq \pi/2$$

$$\quad \pi/2 \leq (\theta - \omega t + \psi) \leq \pi \quad (29)$$

and a_1 , required in equation (28), becomes

$$a_1 = \left[\int_{-\pi/2}^{\pi/2} \cos \eta \cos \eta \, d\eta \right] / \left[\int_{-\pi}^{\pi} \cos^2 \eta \, d\eta \right] = 1/2 \quad (30)$$

The power output equation becomes

$$P_o = \left[R\alpha\omega\alpha_T Q_o \sin(-\psi - \Phi_1) \int_0^1 M_z(x) dx \right] / 2kh p [1 + (q-1)^2/p^2]^{1/2} \quad (31)$$

Given the material thermal and geometric properties, the operating speed, the flux intensity and location, and the applied moment distribution, one can compute the power output for the engine.

Special Case $|q| \ll 1, p \ll 1$. For many engines and operating conditions the approximations

$$|q| = 4\xi\epsilon T_A^3 R^2 / kh \ll 1 \quad (32)$$

and

$$|p| = \rho c \omega^2 R^2 / k \gg 1 \quad (33)$$

are valid. If these conditions are introduced into the power equation (31) and the phase angle equation (23) one obtains

$$P_o = (\alpha_T Q_o / 2h\rho c R) \sin[\psi + (\pi/2)] \int_0^1 M_z(x) dx \quad (34)$$

Thus the power is maximum if the thermal radiation is on "top" ($\Psi = 0$) of the tube and zero if the thermal radiation is to the side ($\Psi = \pm\pi/2$) of the tube. Note also that the power output is negative if $|\Psi| < \pi/2$ (but less than π).

If the applied moment distribution is uniform along the length of the tube ($M_z(x) = M_{z0}$) then

$$P_o = (M_{z0}\alpha_T Q_o / 2h\rho c R) \sin[\psi + (\pi/2)] \quad (35)$$

The thermal power input to the engine is

$$P_i = 2\alpha_T Q_o R l \quad (36)$$

therefore, the thermal efficiency is

$$e_T = (M_{z0}\alpha / 4h\rho c R^2) \sin[\psi + (\pi/2)] \quad (37)$$

The maximum stress in the tube is related to the moment by

$$\sigma_{max} = M_{z0} / \pi R^2 h \quad (38)$$

therefore, the thermal efficiency can be written

$$e_T = (\pi\sigma_{max}\alpha / 4\rho c) \sin[\psi + (\pi/2)] \quad (39)$$

or with thermal radiation on "top" of the tube ($\Psi = 0$):

$$e_T = \pi\sigma_{max}\alpha / 4\rho c \quad (40)$$

In an experimental engine built along the lines illustrated in FIG. 1 the working substance was stainless steel (type 304 annealed) which has been welded into a thin walled cylindrical configuration to form tube 12. The surface of tube 12 was sprayed with a thin coat of

flat black paint to increase absorptivity and emissivity. An almost uniform bending moment was applied to tube 12 by annular weights 26 and 28 mounted on shafts 14 and 16 between the ends of tube 12 and the support bearings 22 and 24. The stress applied to tube 12 was easily varied by translating the weights along the shafts.

Radiant energy was provided in the laboratory by a string of photographers photo-spot lamps, and the thermal flux intensity on the tube 12 was controlled over a range of one to a maximum of about five solar constants by changing the distance between the lamps and the tube. The lamps were positioned slightly off the vertical plane by about 5° so that the engine would be self starting. The performance data for the experimental engine is shown graphically in FIG. 6.

Net torque was measured by a Prony break, and the net power output was computed. Frictional aerodynamic and visco-elastic power losses were established from the lamps-off (at operating temperature) decay rates of the engine speed. The total power output curve is the sum of the power loss in the new power.

The thermal energy passing through the working substance was determined with the aid of a transient calorimeter constructed with the curvature of the tube 12 and sprayed with a thin coat of flat black paint. The theoretical power output shown in FIG. 6 was obtained by multiplying the theoretical thermal efficiency factor (equation 40) by the experimentally determined thermal energy input. The discrepancy between theory and experiment could be attributed to many factors, however, the most probable sources of error were (a) accuracy of material properties used in calculating theoretical efficiency, (b) accuracy of the loss measurements since these data were taken for lamps-off condition (although near operating temperature), and (c) accuracy of the experimental determination of the thermal input to the tube.

In the analysis for thermal efficiency, the dominant mechanism for heat rejection from the tube was assumed to be radiation (equation 10). If convective heat transfers are calculated and compared to the radiative heat transfer at the conditions of the test, the two will be comparable in magnitude. Additional analysis not included here demonstrates that the thermal efficiency

is governed by the circumferential variation in the heat transfer rather than by its magnitude. If all heat were rejected at the tube bottom rather than uniformly around the tube for example, the thermal efficiency would increase by a factor of 2. Forced convection caused by the angular velocity of the tube should give rise to heat rejection uniform with respect to circumference and therefor will predict the same thermal efficiency as for radiation. If natural convection dominates however, heat rejection will be largest at the bottom of the tube and the thermal efficiency would be increased.

Two types of instabilities were encountered in the operation of the experimental engine, one at low speeds and one at high speeds. Both instabilities were apparently due to the coupling of the thermal input and the tube deformations. The low speed instability range is indicated in FIG. 6. At these speeds a thermally induced bow forms in the tube which produces an unbalance of the rotating weights. Because of the unbalance the bowed region moves at lower angular velocities when passing the heat input plane thereby causing an increase in the amount of thermal bow.

The amplitude of the bow increases until the unbalance is so large that the engine rotation ceases. However, rotation can be restored by reducing the torque loading to a value that permits the engine running speed to exceed the minimum instability speed.

The second instability occurred when the engine was operated at speeds near one-half the first critical speed, defined as the speed corresponding to the first mode bending frequency of the tube. When this speed was approached, a thermally coupled operational instability occurred which rapidly built up without apparent limit cycle.

The relatively high losses of the experimental engine reflected in FIG. 6 have been determined to result from joint slippage in the connection between the shafts and the tube and in a later modification in which the joint was welded the losses were significantly reduced.

Referring now to FIG. 7 of the drawing, an embodiment similar to that of the FIG. 1 embodiment, but modified for use in a gravity-free environment such as outer space, is shown at 110. As in the previous embodiment the structure includes a cylindrical tube 112 forming a working body having shafts 114 and 116 affixed to each end. The shafts are journaled to a pair of supports 118 and 120 by bearings 122 and 124. The primary difference between this embodiment and that previously described is that since there are no gravity forces to act upon annular stressing weights, means must be provided for simulating the gravity function. In this case, such stressing forces are applied by means of spring loaded bearing structures 126 and 128 which apply biasing forces downwardly toward the support base 119. A suitable radiation focusing means 130 is positioned to focus rays of sunlight or other radiation onto a particular longitudinal portion of tube 112.

Since the apparatus 110 must always be oriented so that the focusing means 130 can focus sun rays onto a particular portion of tube 112, means such as the inertially stabilized platform schematically illustrated at 160 must be provided along with a suitable sun position locating means 162 and an engine position control mechanism 164. Locator 162 detects the relative position of the sun and develops an output signal for energizing position control means 164 causing it to main-

tain engine 110 oriented in the proper direction relative to the sun.

Still another alternative embodiment of the present invention can be constructed without weights for use in a non-gravitational environment by closing the tube upon itself to form a torus 212 as illustrated in FIG. 8 of the drawing. The tube must undergo only elastic bending when it is formed into a torus. Torus 212 is likewise coated with a layer of black paint or the like to increase its absorptivity and emissivity, and is suspended within a housing 214 by any suitable means. For example, ring magnets 216 may be positioned within housing 214 for creating a magnetic field to magnetically suspend the torus within housing 214. Positioned at the bottom of housing 214 and aligned with the central aperture of torus 212 is a parabolic reflector 218 which is designed to reflect radiation from the sun onto a particular portion of the facing surfaces of the torus.

Housing 214 is provided with a circular opening 220 for allowing the sun rays to reach reflector 218 while at the same time masking rays which would otherwise impinge directly upon the surface of torus 212. Where this embodiment is to be used in an outer space embodiment a suitable guidance reference such as the suggested inertially stabilized platform 260 may be provided for carrying a sun locator 262 and a position control means 264 as in the previous embodiment. Sun detector 262 will detect the relative location of the sun and generate an electrical signal for energizing control means 264 which will in turn orient engine 210 in the proper direction to receive the rays of sunlight.

In operation, as the solar rays are received and reflected by reflector 218 onto a particular quarter section of torus 212, the metallic fibers in the irradiated region will tend to expand due to the increase in temperature and as in the previous embodiment create internal forces within torus 212 which tend to impart rotary motion to the structure causing it to roll about its own axis. In order to provide a power take-off, any suitable means of coupling may be provided which is consistent with the particular suspension mechanism utilized. It will be appreciated that in this embodiment heat applied to the inner annular surfaces of the torus will enable the device to deliver power without the use of either weights or externally loaded bearings to stress the cylindrical body.

Whereas the above description has been limited to three simplified embodiments it is to be understood that these embodiments are greatly simplified and offered for purposes of illustration only. It is contemplated that after having read the above disclosure, one of ordinary skill in the art will envision many other alterations, modifications and further embodiments of the invention. It is therefore to be understood that the above disclosure is not to be taken as limiting and that the appended claims are to be interpreted as covering all such alterations and modifications as fall within the true spirit and scope of the invention.

We claim:

1. Thermal engine apparatus, comprising:
 - a generally tubular body having a circular transverse cross section mounted for rotation about its axis of symmetry, said body having axially directed compressive forces developed therein on one side of said axis and axially directed tensile forces devel-

oped therein on the opposite side of said axis; and

means for heating the compression loaded side of said body whereby the resultant expansion causes internal forces to be developed within said body tending to impart rotational motion of said body about said axis.

2. Thermal engine apparatus as recited in claim 1 wherein said body includes an elongated tubular member journaled at one end to means for applying a clockwise bending moment to said body and journaled at the opposite end to means for applying a counterclockwise bending moment to said body; said bending moments being operative to develop additional compressive and tensile forces in said body.

3. Thermal engine apparatus as recited in claim 1 wherein said body includes an elongated tubular member bowed end-to-end to form a torus having said compressive forces developed within its inner annular portion and said tensile forces developed within its outer annular portion.

4. Thermal engine apparatus for converting radiant energy to rotational kinetic energy comprising:

a hollow, elongated, generally cylindrical body disposed to have its longitudinal axis lying along the intersection of an imaginary horizontal plane and an imaginary vertical plane, said body being divided by said planes into four imaginary longitudinal quadrants;

stressing means for applying forces to said body for causing the quadrants disposed on one side of said planes to be subjected to compression and the quadrants disposed on the opposite side of said one plane to be subjected to tension; and

means for positioning said body relative to a source of radiant energy so that said radiant energy strikes one of said quadrants subjected to compression and transfers thermal energy thereto, said positioning means including means for rotably supporting said body about said axis, said thermal energy causing expansion, increased stress, and rotary motion in said body, said rotary motion being about said longitudinal axis.

5. Thermal engine apparatus as recited in claim 4 wherein said stressing means includes means for applying a clockwise moment lying in said vertical plane to one end of said body and for applying a counterclockwise moment lying in said vertical plane to the

other end of said body.

6. Thermal engine apparatus as recited in claim 4 wherein said body includes a metallic tubular member having an exterior surface coated with a layer of optically black material having better heat absorptivity and emissivity characteristics than said member.

7. Thermal engine apparatus as recited in claim 4 and further comprising means for directing radiant energy onto said body, and wherein said means for positioning said body includes a sun locator and servo means for orienting said body so that the radiant energy from the sun impinges on one of said body quadrants subjected to compression.

8. Thermal engine apparatus as recited in claim 4 wherein said stressing means includes a collar-like weight member disposed about said body.

9. Thermal engine apparatus as recited in claim 4 wherein said means for positioning said body includes a first end support and a second end support respectively engaging opposite ends of said body, and wherein said stressing means includes force applying means located adjacent each of said end supports and operative to apply forces which tend to bend said body in an arc.

10. Thermal engine apparatus as recited in claim 9 wherein said force applying means includes a first collar-like weight member disposed about said body proximate one end of said body, and a second collar-like weight member disposed about said body proximate the opposite end of said body.

11. Thermal engine apparatus as recited in claim 9 wherein said force applying means includes means journaled to said body and affixed to said end support means for applying transverse loading to said body.

12. Thermal engine apparatus, comprising: an elongated tubular member closed upon itself to form an annular body having an inner annular portion subjected to compressive stress and an outer annular portion subjected to tensile stress; and means for applying heat to said inner annular portion whereby resultant expansion of that portion creates forces within said body which tend to cause the portion of said body presently forming said inner annular portion to rotate into the position of the portion of said body forming said outer annular portion and vice versa.

* * * * *

50

55

60

65