

Lang boy



NATIONAL AERONAUTICS AND SPACE ADMINISTRATION

WASHINGTON, D.C. 20546

JUL 2 1974

REPLY TO  
ATTN OF: GP

TO: KSI/Scientific & Technical Information Division  
Attn: Miss Winnie M. Morgan

FROM: GP/Office of Assistant General  
Counsel for Patent Matters

SUBJECT: Announcement of NASA-Owned U.S. Patents in STAR

In accordance with the procedures agreed upon by Code GP and Code KSI, the attached NASA-owned U.S. Patent is being forwarded for abstracting and announcement in NASA STAR.

The following information is provided:

U.S. Patent No. : 3,817,084

Government or Corporate Employee : U.S. Government

Supplementary Corporate Source (if applicable) : \_\_\_\_\_

NASA Patent Case No. : LAR-10,841-1

NOTE - If this patent covers an invention made by a corporate employee of a NASA Contractor, the following is applicable:

YES  NO

Pursuant to Section 305(a) of the National Aeronautics and Space Act, the name of the Administrator of NASA appears on the first page of the patent; however, the name of the actual inventor (author) appears at the heading of column No. 1 of the Specification, following the words "...with respect to an invention of ..."

*Bonnie L. Woerner*

Bonnie L. Woerner  
Enclosure

(NASA-Case-LAR-10841-1) APPARATUS FOR INSERTING AND REMOVING SPECIMENS FROM HIGH TEMPERATURE VACUUM FURNACES Patent (NASA) 5 p CSCL 14B N74-27900 Unclas 00/15 41865

[54] **APPARATUS FOR INSERTING AND REMOVING SPECIMENS FROM HIGH TEMPERATURE VACUUM FURNACES**

[75] Inventor: **Charles W. Whitehead**, Newport News, Va.

[73] Assignee: **The United States of America as represented by the Administrator of the National Aeronautics and Space Administration**, Washington, D.C.

[22] Filed: **Nov. 17, 1972**

[21] Appl. No.: **307,729**

[52] U.S. Cl. .... **73/15 R, 13/31**

[51] Int. Cl. .... **G01n 25/00**

[58] Field of Search..... **73/15 R, 19, 190 R, DIG. 5; 250/288; 214/17 B; 310/104; 13/31**

[56] **References Cited**  
**UNITED STATES PATENTS**

2,536,813	1/1951	Jones .....	310/104
2,795,132	6/1957	Boehme et al. ....	73/19
2,882,410	4/1959	Brobeck .....	250/288
3,176,500	4/1965	Coe .....	73/19
3,340,176	9/1967	Belluso .....	214/17 B

Primary Examiner—S. Clement Swisher  
Attorney, Agent, or Firm—Howard J. Osborn; Wallace J. Nelson; John R. Manning

[57] **ABSTRACT**

A high temperature vacuum furnace having secured to the port thereof apparatus for the insertion of specimens to be tested and removal thereof from the test zone of the furnace. The apparatus comprises a high speed gate valve for isolating the interior of the furnace from an air lock chamber on the opposite side of

the gate valve. The air lock chamber is provided with valve ports connected to a vacuum source, a source of inert quenching gas, and the atmosphere, respectively. Removeably attached to the end of the air lock chamber away from the furnace is a cylindrical tube having disposed within it a rod carrying a specimen pan at its end towards the furnace and having mounted at its top end an annular magnet having a diameter slightly less than the interior diameter of the tube. The top end of the tube is closed by a removeable cap. Encircling the tube in the vicinity of the magnet is a carbon steel ring which when axially moved along the tube causes the magnet to follow it and thereby controls the position of the rod and specimen pan within the tube.

In an alternative embodiment, the magnet is replaced by an iron slug which serves as an armature for the coil of the solenoid which replaces the carbon steel ring.

The specimen is inserted in the furnace without cooling the furnace down or disturbing the vacuum by first removing the tube from the outer end of the air lock chamber, placing the material to be tested in the specimen pan, and replacing the tube on the outer end of the air lock chamber. The valve in the port connected to the source of the vacuum is then opened to bring the pressure in the air lock chamber to that of the furnace. The gate valve is then opened and the ring moved along the tube towards the furnace thereby moving the rod and specimen pan until the specimen pan is within the test zone of the furnace. After the completion of the test, the specimen pan is moved to the air lock chamber, the gate valve closed, the specimen cooled, and the chamber brought to atmospheric pressure. Optionally, the specimen may be quenched with inert gas.

**12 Claims, 2 Drawing Figures**

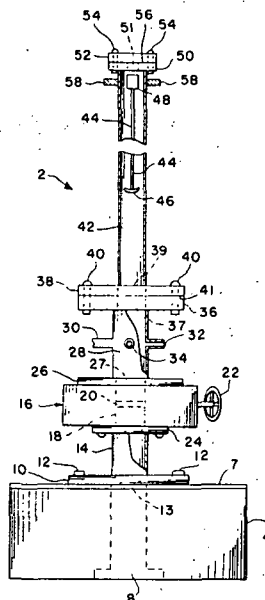

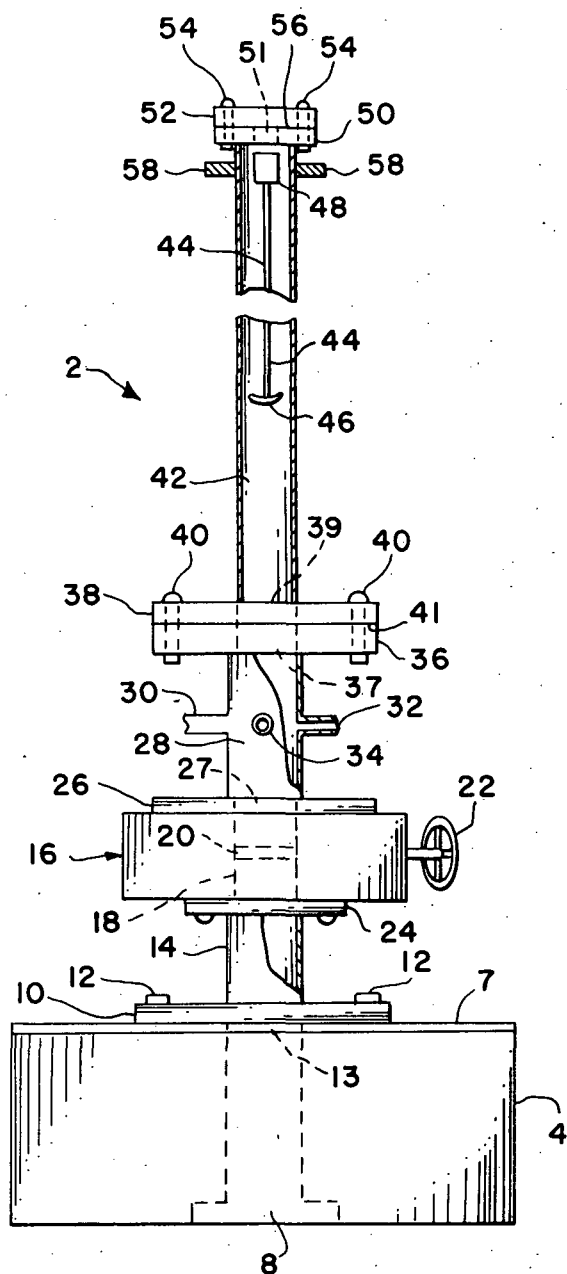

FIG. 1

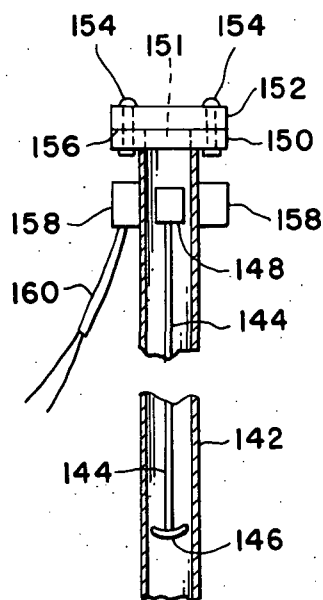

FIG. 2

# APPARATUS FOR INSERTING AND REMOVING SPECIMENS FROM HIGH TEMPERATURE VACUUM FURNACES

## ORIGIN OF THE INVENTION

The invention described herein was made by an employee of the National Aeronautics and Space Administration and may be manufactured and used by or for The Government of the United States for governmental purposes without the payment of any royalties thereon or therefor.

## BACKGROUND OF THE INVENTION

There presently is an expanding need for economical ways of testing materials in a vacuum at very high temperatures. This type of testing has become particularly important with the advent of requirements for high temperatures materials for use in space vehicles and the like. Up to the present time, the insertion and removal of test specimens from high temperature vacuum furnaces, which operate at temperatures on the order of 3,600°F and higher, has required extremely long cycling times. Quite often the time required to cool the furnace down, remove the specimen from the furnace, replace it with another specimen, and then bring the furnace up to test temperature and vacuum, required a period of five hours or more. Removal of the specimen required shutting down the furnace, bringing the furnace to atmospheric pressure, and then removing the specimen. Only then could another specimen be inserted and the furnace reheated, and a vacuum drawn again. As indicated, this was time consuming and consequently expensive.

The present invention is concerned with an easily operated air lock mechanism which permits specimens to be inserted and removed from high temperature vacuum furnaces in a very short time, i.e., twenty minutes or less, without decreasing furnace temperature or degree of vacuum. The present invention thus provides a great economical saving in the operation of high temperature vacuum furnaces.

There is no prior art known to applicant which provides apparatus for rapidly inserting and removing test specimens from high temperature vacuum furnaces. U.S. Pat. No. 2,874,107 discloses a neutronic reactor having an attachment thereto for placing materials to be irradiated in the reactor and for removing them from the reactor. It is extremely complex and unsuitable for utilization in high temperature vacuum furnaces.

## SUMMARY OF THE INVENTION

According to the present invention, there is provided an air lock mechanism which is attached to high temperature vacuum furnaces which allows a test specimen to be removed from the furnace and replaced by a succeeding specimen without lowering the temperature of the furnace or disturbing the vacuum thereof within a cycling time of approximately twenty minutes. The air lock mechanism includes a high speed gate valve which is secured over the port of the furnace by a simple adaptor fitting, an air lock chamber mounted on the gate valve on the side of the valve away from the furnace, and a cylindrical tube removeably mounted on the outer end of the air lock chamber. The air lock chamber is provided with valved ports communicating

with a source of vacuum, a source of inert quenching gases, and the atmosphere, respectively. Disposed within the tube that is mounted on the air lock chamber is a specimen pan secured to the inner end of a rod within the tube. The position of the rod and consequently the specimen pan within the tube is magnetically controlled through means of a ring or coil surrounding the outer diameter of the tube acting in cooperation with either a magnet or iron slug at the outer end of the rod. The other end of the tube is closed by a removeable cap.

The specimen is inserted in the furnace by placing the specimen on the specimen pan following removal of the tube from the outer end of the air lock chamber. The tube replaced on the outer end of the air lock chamber and the air lock chamber is brought to a vacuum equal to that within the furnace. The gate valve is then opened, and through magnetic means, the specimen pan is moved into the test zone of the furnace by moving the rod inwardly in the tube. After completion of the test, the rod is withdrawn outwardly until the specimen is within the air lock chamber, the gate valve closed, and the specimen cooled down with or without quenching in inert gases, and the air lock chamber brought to atmospheric pressure. The specimen is then removed by removing the tube from the outer end of the air lock chamber.

## BRIEF DESCRIPTION OF THE DRAWING

In the accompanying drawing:

FIG. 1 is a side view, partially in section, of the apparatus of the present invention attached to a high temperature vacuum furnace.

FIG. 2 is a side view, partially in section, of an alternative embodiment of a portion of the apparatus shown in FIG. 1.

## DESCRIPTION OF PREFERRED EMBODIMENTS

Referring to FIG. 1 of the accompanying drawing, the apparatus of the present invention indicated generally at 2 is shown attached to a high temperature vacuum furnace 4. The furnace 4 has, as shown by the dotted lines, a test heating zone 8 that is located in the center of the furnace 4 which in the embodiment shown is cylindrical. Attached to the top 7 of the furnace by means of an annular flange 10 secured to the furnace 4 by bolts 12 is a hollow cylindrical adaptor 14, the top of which is connected by way of flange 24 to a high speed gate valve indicated generally at 16. The adaptor 14 fits over port 13 of the furnace 4 and is axially aligned therewith. The gate valve 16 may be one which is manually operated or preferably is a vacuum operated valve to assure high speed operation. Pneumatically or electrically operated gate valves may also be utilized. The valve 16 has a cylindrical passage 18 passing through the body of the valve which, when the valve 16 is in the closed position, is closed by the gate 20 indicated schematically in the drawing. In the drawing, the actuator of the valve 16, in this case the handle, is indicated at 22. Secured to the top of the valve 16 by means of flange 26 having a central opening 27 and bolted to the body of the valve 16, is a hollow cylindrical air lock section or chamber 28. The cylindrical air lock chamber 28 which is preferably made of 347 stainless steel is provided with valved ports 30, 32 and 34, respectively, communicating with the interior of the chamber 28.

The port 30 is in turn connected to a vacuum source, not shown, the port 32 to a source of inert gas, not shown, and the port 34 connects directly with the surrounding atmosphere. The top end of the chamber 28 is provided with an annular flange 36 having a central opening 37 therein. The flange 36 is in turn connected to a similar annular flange 38 with opening 39 at the base of the hollow cylinder tube 42 by bolts 40. The flanges 36 and 38 are sealed along their interface 41.

As described in greater detail below, the bolts 40 may be removed and the flanges 36 and 38 separated to provide for a removal of tested specimens and insertion of new specimens.

Disposed axially within the tube 42 is a rod 44 having a specimen pan 46 connected to the bottom thereof. A magnet 48, just slightly less in diameter than the internal diameter of the tube 42, is secured to the top of rod 44. Rod 44 and specimen pan 46 may be constructed of any suitable high temperature resistant material as will be further explained hereinafter.

A carbon steel ring 58 having an internal diameter only slightly larger than the external diameter of the tube 42 is utilized to control the axial movement of the rod 44. Movement of the ring 58 along the tube is followed by the magnet 48 which in turn moves the rod 44 and pan 46 with the specimen.

Attached to the upper end of the tube 42 is annular flange 50 having a central opening 51 therein. An annular cap 52 is held in place on the annular flange 50 by means of studs 54. The interface of the flange 50 and cap 52 is indicated at 56.

Material to be tested is placed in the specimen pan 46 after the tube 42 with rod 44 and pan 46 have been removed from the top of the air lock chamber 28 by unbolting and separating the flanges 36 and 38.

If desired, rather than separating flanges 36 and 38, the tube 42 with air chamber 28 attached to it can be removed from the top of the valve 16 by unbolting flange 26.

As previously indicated, the position of the rod 44 and consequently the specimen pan 46 within the tube 42 is controlled by moving the ring 58 axially along the outside of the tube 42. This in turn moves the rod 44 as the magnet 48 follows the movement of the ring 58.

After the specimen to be tested is placed in specimen pan 46, the tube 42 is secured to the top of the air lock chamber 28 by bolting flanges 38 and 36 together. The gate valve 16 is in the closed position during the preceding operation. A vacuum is drawn on the air lock section 28 by opening the valve of the port 30 thus placing the air lock chamber in communication with the vacuum source. When the pressure in the air locks equal that in the furnace, the gate valve 16 is opened, the ring 58 is moved axially downwards with the magnet 48 at the top of the rod 44 following until specimen pan 46 arrives within the test zone 8.

Following the test period, the specimen on pan 46 is removed from the heat zone 8 by moving the ring 58 axially along tube 42 away from the furnace, thus moving the magnet 48 and consequently the rod 44 with the specimen pan 46 upward out of the furnace 4. When the pan 46 is within the air lock section 48, the movement of the ring 58 is stopped, the gate valve 16 closed, and the air lock chamber 28 either brought to atmospheric pressure and the specimen allowed to cool, or

if desired, the specimen may be quenched with a flow of inert gas such as helium or argon by opening the valve air port 32 and pumping in the quenching gas. The valve of port 30 is closed at this time.

If desired, the cap 52 can be unbolted so the cap 52 can raise slightly and allow the excess gas pressure to vent at the interface 56 of the cap 52 and flange 50.

As is apparent, the apparatus of this invention permits the removal of the test specimen from the furnace without loss of pressure in the furnace or lowering of the temperature of the furnace. Another test specimen readily can be placed in the furnace by repeating the same procedure after removing the cooled specimen from the air lock chamber. This cycling can be completed in most cases within twenty minutes or less.

In FIG. 2 is shown an alternative embodiment of the mechanism for moving the rod holding the specimen pan.

In this embodiment, the cylindrical tube is indicated at 142 within which is disposed rod 144 and specimen pan 146. The top flange of tube 142 is indicated at 150 being capped by cap 152 secured by studs 154. The interface of the cap 152 and flange 150 is indicated at 156. In this embodiment, the magnet at the top of the rod is replaced by an annular iron slug 148 to which the rod 146 is fixed. The iron slug 148 serves in effect as the armature for the solenoid, the coil windings of which are indicated at 158 and encircle the tube 142. The solenoid 158 is connected to a power source not indicated by conduit 160. The position of the specimen pan 146 is thus controlled by moving the solenoid coil 158 along the tube 142, which in turn causes the armature 148 of the solenoid to move the rod 144 within the tube 142 thereby controlling the position of the specimen pan 146.

The specimen pan and rod should be constructed of high temperature resistant materials such as tantalum, tungsten, molybdenum, graphite, or ceramic. The remaining parts are generally constructed of stainless steel. The tube 42 alternatively may be constructed of clear quartz so that the position of the rod and specimen can be followed visually.

The present invention thus provides apparatus which allows test specimens to be inserted into and removed from a high temperature vacuum furnace easily and rapidly without interrupting the continuous operation of the furnace. Whereas cooling the furnace and the removal of a tested specimen and insertion of a new specimen into the furnace and returning the furnace to test conditions often required five or more hours to accomplish previously, with the apparatus of this invention, the cycling can often be completed in twenty minutes or less.

While the invention has been explained by detailed description of certain specific embodiments, it is understood that various modifications and substitutions can be made in any of them within the scope of the appended claims which are intended also to include equivalents of such embodiments.

What is claimed is:

1. Apparatus for placing a specimen in a high temperature vacuum furnace and removing said specimen therefrom without disturbing the temperature or vacuum of said furnace, said furnace having a port communicating with a test zone in said furnace, said apparatus comprising adaptor means connecting a first side of a gate valve means to said port in said furnace, a sec-

5

6

ond and opposite side of said gate valve means connected to a first side of an air lock chamber, valved means associated with said air lock chamber for selectively placing said chamber in communication with a vacuum source, further valved means associated with said air lock chamber for selectively placing said chamber in communication with the atmosphere, an elongated hollow cylinder tube connected to the second and opposite side of said air lock chamber, specimen holder means movable by means operative from outside of said hollow cylinder tube through said air lock chamber and said gate valve means when opened, and to and from said test zone, said specimen holder means including an elongated rod having a specimen pan secured to one end thereof and a magnet secured to the opposite end thereof and said means operative from outside of said hollow cylinder tube consists of a carbon steel ring slidably disposed thereon.

2. Apparatus as claimed in claim 1 wherein said gate valve means is a vacuum operated gate valve.

3. Apparatus as claimed in claim 1 wherein said air lock chamber includes additional valved means for placing said chamber in selective communication with a source of inert gas.

4. Apparatus for placing a specimen in a high temperature vacuum furnace and removing said specimen therefrom without disturbing the temperature or vacuum of said furnace, said furnace having a port communicating with a test zone in said furnace, said apparatus comprising adaptor means connecting a first side of a gate valve means to said port in said furnace, a second and opposite side of said valve means connected to a first side of an air lock chamber, valved means associated with said air lock chamber for placing said chamber in communication with a vacuum source, further valved means associated with said air lock chamber for placing said chamber in communication with the atmosphere, a hollow tube connected to the second and opposite side of said lock chamber, the interior of said tube being in communication with the interior of said air lock chamber, a rod disposed longitudinally within said tube, a specimen holder removably attached to a first end of said rod, said first end being the end of said rod disposed towards the furnace, a cap closing the second end of said tube, and magnetic means for moving said rod axially within said tube, said magnetic means comprising ring means encircling said tube exteriorly thereof in the vicinity of a cooperative means secured to the second end of said rod, the axial movement of said ring means causing the axial movement of said rod within said tube due to magnetic forces to thereby move said specimen holder through said air lock chamber and through said gate valve

means when opened, and to and from said test zone.

5. Apparatus as claimed in claim 4, wherein ring means comprises a carbon steel ring and said cooperative means comprises a magnet.

6. Apparatus as claimed in claim 4 wherein said ring means comprises a solenoid coil and said cooperative means comprises an iron slug which acts as the armature for said solenoid coil.

7. Apparatus as claimed in claim 4 wherein said gate valve means comprises a vacuum operated gate valve.

8. Apparatus as claimed in claim 4 wherein said gate valve means comprises a manually operated gate valve.

9. Apparatus as claimed in claim 4 wherein said gate valve means comprises a pneumatically operated gate valve.

10. Apparatus as claimed in claim 4 wherein said gate valve means comprises an electrically operated gate valve.

11. Apparatus as claimed in claim 7 wherein said air lock chamber includes valved means for placing said chamber in communication with a source of inert gas.

12. Apparatus comprising adaptor means suitable for connecting a first side of a vacuum operated gate valve to a port of a high temperature vacuum furnace having a test zone therein, a second and opposite side of said gate valve connected to a first side of an air lock chamber, first valved means associated with said air lock chamber for placing said chamber in communication with a vacuum source, second valved means associated with said air lock chamber for placing said chamber in communication with the atmosphere, and third valved means associated with said air lock chamber for placing said chamber in communication with a source of inert gas, a hollow tube connected to the second and opposite side of said air lock chamber, the interior of said tube being in communication with the interior of said air lock chamber, a rod disposed longitudinally within said tube, a specimen holder removably attached to a first end of said rod, said first end being the end of said rod disposed towards said furnace, a cap closing the second end of said tube, magnetic means for moving said rod axially within said tube, said magnetic means comprising a solenoid coil encircling said tube exteriorly thereof in the vicinity of an iron slug secured to the second end of said rod, the axial movement of said solenoid coil causing the axial movement of said rod within said tube to thereby move said specimen holder through said air lock chamber and through said gate valve when opened, and to and from said test zone.

\* \* \* \* \*

55

60

65

