



NATIONAL AERONAUTICS AND SPACE ADMINISTRATION

WASHINGTON, D.C. 20546

REPLY TO
ATTN OF: GP

JUN 21 1974

TO: KSI/Scientific & Technical Information Division
Attn: Miss Winnie M. Morgan

FROM: GP/Office of Assistant General
Counsel for Patent Matters

SUBJECT: Announcement of NASA-Owned U.S. Patents in STAR

In accordance with the procedures agreed upon by Code GP and Code KSI, the attached NASA-owned U.S. Patent is being forwarded for abstracting and announcement in NASA STAR.

The following information is provided:

U.S. Patent No.

: 3,812,358Government or
Corporate Employee: Univ. of Wisconsin
Madison, WisconsinSupplementary Corporate
Source (if applicable): _____

NASA Patent Case No.

: GSC-11,492-1

NOTE - If this patent covers an invention made by a corporate employee of a NASA Contractor, the following is applicable:

YES NO

Pursuant to Section 305(a) of the National Aeronautics and Space Act, the name of the Administrator of NASA appears on the first page of the patent; however, the name of the actual inventor (author) appears at the heading of column No. 1 of the Specification, following the words "...with respect to an invention of ..."

Bonnie L. Woerner

Bonnie L. Woerner
Enclosure

[54] COAXIAL ANODE WIRE FOR GAS RADIATION COUNTERS

[76] Inventors: James C. Fletcher, Administrator of the National Aeronautics and Space Administration with respect to an invention by; William L. Kraushaar, 1003 Oak Way, Madison, Wis. 53705

[22] Filed: June 21, 1973

[21] Appl. No.: 372,148

[52] U.S. Cl. 250/385, 250/374, 313/93

[51] Int. Cl. G01t 1/18, H01j 39/28

[58] Field of Search 250/374, 385, 390; 313/93

[56] References Cited

UNITED STATES PATENTS

2,975,288	3/1961	Minowitz et al.	250/385
3,385,988	5/1968	Hyun	313/93 X
3,649,834	3/1972	Randolph	313/93 X

Primary Examiner—Archie R. Borchelt
Attorney, Agent, or Firm—Robert F. Kempf; John R. Manning; John H. Warden

[57] ABSTRACT

A coaxial anode construction for a gas radiation counter is disclosed by which undesirable background ionization interference may be suppressed. The anode comprises an elongated central wire covered with an electrically insulating sleeve. A plurality of longitudinally discontinuous segments of an electrically conductive coating is disposed about the insulating sleeve in coaxial relationship to and along the length of the central wire. In the preferred inventive embodiment, the plurality of conductive coating segments define a so-called veto or rejection anode at each end portion of the central wire and a main or primary charge detecting anode disposed therebetween. Coupling means are connected to each of the segments such that the primary charge detecting anode is connected to detection circuitry in anti-coincidence with the veto anodes. Background radiation detected by either of the veto anodes and the primary charge detecting anode is therefore rejected and the sensitivity of the radiation counter device is increased.

7 Claims, 2 Drawing Figures

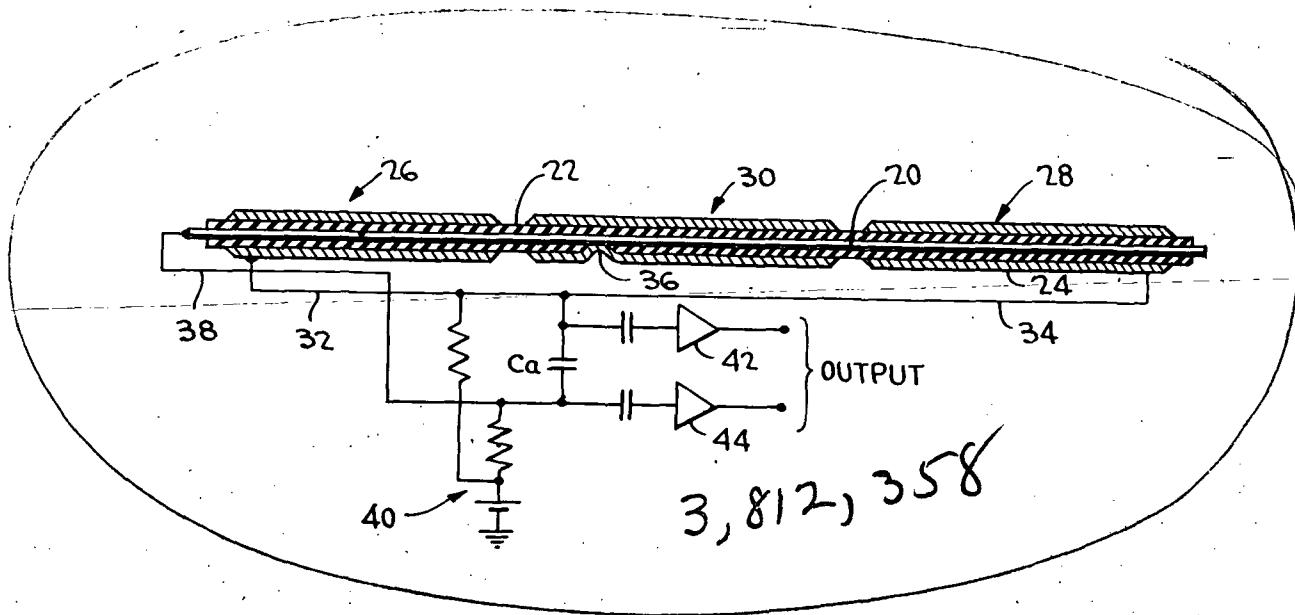

(NASA-Case-GSC-11492-1) COAXIAL ANODE
 WIRE FOR GAS RADIATION COUNTERS Patent
 (NASA) 6 p CSCL 14B
 N74-26949
 00/14 40488
 Unclas

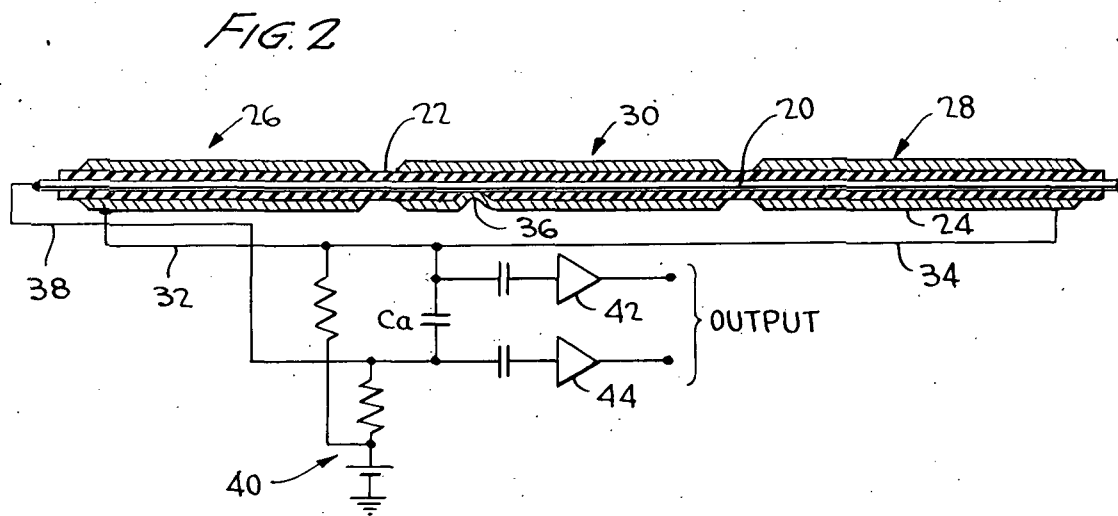
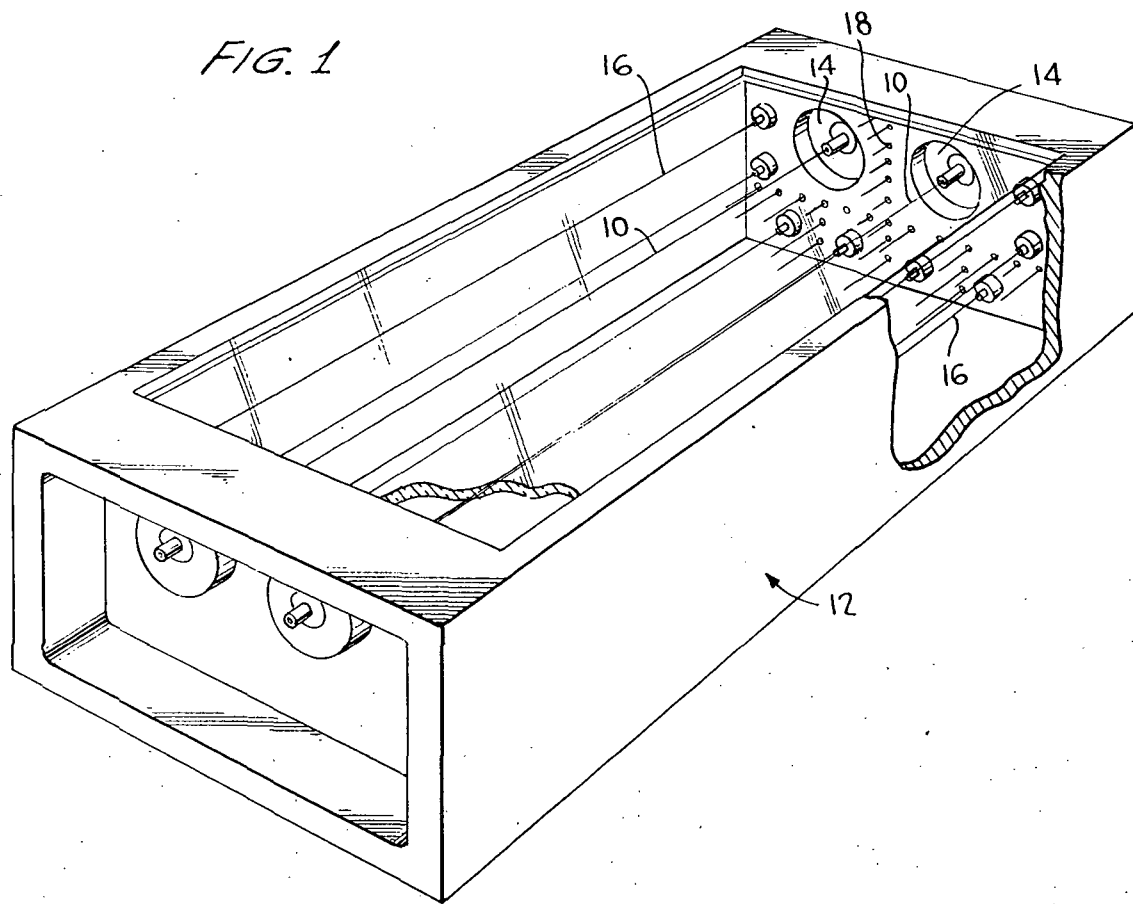

COAXIAL ANODE WIRE FOR GAS RADIATION COUNTERS

ORIGIN OF THE INVENTION

The invention described herein was made in the performance of work under a NASA contract and is subject to the provisions of Section 305 of the National Aeronautics and Space Act of 1958, Public Law 85-568 (72 STAT. 435; 42 USC 2457).

BACKGROUND OF THE INVENTION

This invention generally relates to gas radiation counter technology and particularly concerns the provision of a coaxial anode construction therefor by which undesirable background ionization interference can be suppressed.

The sensitivity of typical gas radiation detectors, i.e., the minimum detectable signal of the perturbation of interest, is frequently limited by the presence of a background of ionizing particles which cannot be distinguished in simple detectors from the radiation for which the detector is designed. For example, with typical X-ray proportional counters, the detected radiation rate is composed of two parts, the "signal" due to cosmic X-rays incident upon the instrument, and the "noise" or non-X-ray background, the non-X-ray background being primarily caused by incident charged particles such as cosmic rays and charged particles created by gamma rays which interact in the body of the radiation counter or other nearby material.

With such detectors, it is desirable to provide a scheme whereby the background "noise" can be rejected, thus enabling a more sensitive detection of the actual signal. One technique by which such background rejection is achieved is through pulse shape discrimination, particularly discrimination of the rise times of the pulses produced by the incident radiation. In this respect, the charged particles responsible for the background noise have trajectories that include a range of distances from the counter anode which results in long anode pulse rise times. These long pulse rise times can be distinguished from the shorter rise time pulses produced by localized ionization due to the incident X-rays of interest. To effect such pulse shape discrimination, complicated and expensive detection circuitry is necessary and, the pulse shape discrimination scheme rapidly loses its effectiveness with decreasing energy of the incident radiation. These undesirable disadvantages of the pulse shape discrimination technique have limited the use of such technique to few environments.

Another technique by which the rejection of unwanted background radiation can be achieved is through the utilization of background detectors which are disposed about the primary detector on as many sides as possible, the background detectors serving to "veto" or reject unwanted events which simultaneously trigger both a primary and a background detector. To provide separate background of "veto" detectors disposed about the primary detector generally requires the utilization of walls between the various detectors which subsequently results in a loss of rejection efficiency. Further, the primary detector while being surrounded on its sides with background detectors, thus providing a modicum of background radiation rejection in these directions, has not heretofore been provided with rejection detectors disposed at the ends of

the primary detector. Thus, while the concept of providing separate "veto" anodes or background detectors in combination with a primary detector in such gas radiation counters show promise, acceptable results still have not been obtained.

SUMMARY OF THE INVENTION

It is the primary objective of the instant invention to provide a coaxial anode construction for such gas radiation counters by which undesirable background ionization interference may be suppressed in a manner overcoming the undesirable characteristics of prior art approaches.

It is a further objective of the instant invention to provide an anode construction which specifically is effective to reject background radiation interference occurring at or near the ends of a primary detector.

These objectives, as well as others which will become apparent as the description proceeds, are implemented by the provision of a coaxial anode which essentially constitutes a single anode wire disposed in a gas radiation counter, which single anode wire is split into electrically separate segments which can serve as separate detectors in a minimum of space and without the loss of efficiency that would accompany disturbing the geometry of the radiation counters with walls, gaps, and/or separate anodes.

In the exemplary environment of use, i.e., in an X-ray proportional counter, the primary radiation to be detected is X-rays which are detected in the gas of a proportional counter in a single photoelectric interaction, while the undesirable background interference is usually caused by ionizing cosmic rays which may penetrate the radiation counter from all directions. Thus, the plurality of electrically separate segments created from the single anode wire is such as to define so-called "veto" segments at each end of the main or primary charge detecting anode. This disposition of "veto" segments provides the needed background protection at the ends of each counter with a high degree of efficiency and in a compact geometry. All segments of the split single anode wire are contemplated to be supplied by the same high voltage so as to provide a uniform electric field along the length of the counter, while events occurring in the different portions of the counter may be counted separately.

From the standpoint of physical construction, the coaxial anode of the instant invention will be seen to comprise an elongated central wire having an electrically insulating sleeve disposed thereabout. A plurality of longitudinally discontinuous segments of an electrically conductive coating is disposed about the insulating sleeve in coaxial relationship to and along the length of the central wire, the plurality of segments respectively defining a "veto" anode at each end portion of the central wire, and a primary charge detecting anode disposed therebetween.

In this particular though still exemplary case of a three-segment wire having a central signal anode interposed between the two end of "veto" anode segments, a connection can be made between the central segment of the outer conductive coating and the central wire by removing a small area of insulation before the outer conductive coating is applied, such application being by a vapor deposition process, for example. In this fashion, the central segment, which constitutes the primary charge detecting anode, is electrically connected to the

central wire. Access to all three segments for electrical connections, i.e., access to both veto anodes and the primary charge detecting anode, is available at the ends of the wire and therefore outside the gas-filled detection space. When the central segment is connected to detecting circuitry in anti-coincidence with the end or veto segments, the single coaxial anode wire serves to detect ionizing radiation in the vicinity of the central segment and reject events which simultaneously yield ionization in the vicinity of either end segment.

BRIEF DESCRIPTION OF THE DRAWINGS

The invention itself will be better understood, and further features and advantages thereof will become apparent, from the following detailed description of a preferred, though exemplary, embodiment, such description making reference to the appended sheet of drawings, wherein:

FIG. 1 is a perspective illustration of portions of a typical gas radiation counter, such as an X-ray proportional counter, which counter utilizes a plurality of rejection or "veto" anodes surrounding a main or primary charge detecting anode on several sides thereof, and

FIG. 2 is a sectional illustration of a coaxial anode wire constructed in accordance with the teachings of the instant invention by which "veto" or rejection anode segments are provided to either end of the central or primary charge detecting anode to thereby effect rejection of background events occurring near the ends of the primary charge detecting segment.

DETAILED DESCRIPTION OF A PREFERRED INVENTIVE EMBODIMENT

With reference now to the drawings, and particularly to FIG. 1 thereof, a typical gas radiation counter construction is disclosed, such as an X-ray proportional counter. With such an exemplary counter, several primary detector wires are provided such as wires 10, each of the wires 10 constituting a coaxial anode construction of the type of the instant invention and as will be described in detail hereinbelow.

The anode wires 10 are disposed in the interior of a generally rectangular gas radiation counter 12, the interior of radiation counter 12 constituting a gas-filled space as is conventional. The anode wires 10 are connected to the opposing end walls of the radiation counter 12 by means of anode seals 14. In usual fashion, though not illustrated in the drawing, the top portion of the radiation detector 12 would be provided with a cover having a radiation-transparent window therein so as to allow entry of radiation into the gas-filled space. A potential difference is maintained between the walls of the radiation counter 12 and the main anode wires 10 such that the entry of primary radiation of interest, such as X-rays, within the gas volume creates ionization therein resulting in a pulse delivered from the charge detecting anode to external detection circuitry.

With such radiation counters, it is desirable as mentioned above to protect the main or primary charge detecting anodes 10 from undesirable background radiation. To this end, a plurality of "veto" or rejection anodes such as indicated by reference numeral 16 are disposed in the gas volume and preferably about three of the six sides of the X-ray counting volume as is indicated. These "veto" anodes are connected to the exter-

nal circuitry of the detector in anti-coincidence with the main or primary charge detecting anodes 10. As such, ionization sensed by both the primary charge detecting anode 10 and a veto anode 16 is rejected as constituting background noise. Only radiation that is detected by a primary anode 10 alone is considered to constitute "signal" in the external detecting circuitry.

Disposed between each of the "veto" anodes 16 and between each of the primary anodes or wires 10 are a plurality of fine wires constituting ground wires such as designated by reference numeral 18, these ground wires running parallel to the veto anodes and the primary charge detecting anodes and serving to electrically separate the veto anodes from the X-ray counter volume. As such, the veto anodes or counters are part of the same gas volume as the primary X-ray counters and this arrangement has been found to be particularly effective with respect to background radiation rejection since there are no walls and little other material in which the undesirable charged particles can come to rest.

With the above construction alone, a marked advance in background radiation rejection has been achieved in that the veto counters or anodes readily protect three or four of the six sides of the X-ray counting volume. With low-energy radiation environments, this limited protection can in itself be sufficient to reject background radiation and provide a desirable degree of sensitivity for the counter. In other types of X-ray investigations, wherein the observation times are long, for example, the measurements effected by the radiation counter ultimately will be background-limited even with the provision of the rejection or veto anodes as is shown in FIG. 1. Specifically, a large portion of residual non-X-ray background noise has its origin in the unprotected ends of the primary or main anodes 10, where the anode wires are terminated in the walls of the counter. Therefore, the instant invention provides an additional technique whereby background rejection of events occurring near the ends of the primary anode wires can readily be achieved.

With reference now to FIG. 2 of the appended drawings, a coaxial anode construction in accordance with the instant invention is illustrated, the coaxial anode being contemplated to comprise anode wires 14 in a radiation counter of the type above-described.

In this respect, an elongated central wire 20 is provided and is contemplated to run the entire length of the gas radiation counter in which it is used. Central wire 20 in the preferred inventive embodiment constitutes a tungsten wire of a thickness of approximately 0.001 inches. Disposed about the central wire 20 is an electrically insulating sleeve 22 of suitable insulating material such as an enamel insulation or the like. In the preferred inventive embodiment, insulating sleeve 22 is contemplated to comprise an Isonel insulator of a thickness in the neighborhood of 0.0005 inches. It is preferable, however, to utilize a somewhat thicker insulation so as to reduce capacitance and uncompensated cross-talk.

A plurality of longitudinally discontinuous segments of an electrically conductive coating is disposed about the insulating sleeve in coaxial relationship to and along the length of the central wire 20, the electrically conductive coating being generally designated by reference numeral 24 and constituting vapor-deposited

gold, for example, which preferably has a resistance of 30 ohms per inch or less after deposition. The discontinuous electrically conductive coating 24 defines a plurality of segments. In the embodiment illustrated, a "veto" or rejection anode segment 26 and 28 is provided near each end portion of the central wire 20. Disposed between each "veto" anode segment is a primary charge detecting anode segment 30.

Electrical connection is contemplated to be made to each of the anode segments so produced on the coaxial anode wire at a location near the end of the coaxial anode outside the gas-volume of the radiation counter. To this end, an electrical wire is connected to "veto" segment 26 as illustrated by reference numeral 32, and a further connection is made to veto segment 28 as illustrated by reference numeral 34.

To make electrical contact with the central section constituting the primary charge detecting anode, a less direct technique is utilized. For example, a small section of the electrical insulation 22 located near the center of the coaxial anode such as at location 36 is removed before the outer electrically conductive coating 24 is applied. The outer electrically conductive coating 24 therefore deposits over this removed section at location 36 and provides the requisite electrical connection between the inner or central wire and the primary charge detecting segment 30. Electrical connection then is made by means of a wire 38 disposed outside the counter volume and connected to the central wire 20 and thus to primary charge detecting anode 30.

In the preferred embodiment, a high voltage is applied to each of the anode segments 26, 28 and 30 by means of a representative voltage source 40. In the preferred embodiment, the same high voltage is applied to each of the plurality of anode segments so that a substantially uniform electric field is produced along the length of the central wire.

In a background noise rejection use, the two end or veto anode sections 26 and 28 are electrically coupled in parallel together, as shown, and then to a charge sensitive amplifier 42, whereas the central or primary charge detecting anode 30 is coupled to a charge sensitive amplifier 44, charge sensitive amplifiers 42 and 44 detecting ionization that occurs in the three well-defined regions of gas which surround anode segments 26, 28, and 30. The output from the charge sensitive amplifiers 42 and 44 is contemplated to be connected to detecting circuitry such that the primary charge detecting anode 30 is coupled to the detection circuitry in anti-coincidence with both veto anode segments 26 and 28.

Thus, with the above-described preferred arrangement, ionization that simultaneously occurs at either end of the primary charge detecting anode as well as at the primary charge detecting anode itself is rejected as undesirable background noise. In other embodiments, as will be appreciated, the various anode segments can be coupled to separate amplifiers and detection circuitry whereby each segment can constitute a primary charge detecting segment for different areas of the detector gas volume.

The scope and application of the present invention are by no means limited to the preferred illustrated embodiment which is only exemplary in nature, such scope and application to be construed by the appended claims. It should further be apparent that the objects

initially set forth at the outset of this specification have been successfully achieved. Accordingly,

What is claimed is:

1. A coaxial anode construction for a gas radiation counter by which undesirable background ionization interference may be suppressed, said coaxial anode comprising:

an elongated central wire;
an electrically insulating sleeve disposed about said central wire;

a plurality of longitudinally discontinuous segments of an electrically conductive coating disposed about said insulating sleeve in coaxial relationship to and along the length of said central wire; said plurality of segments respectively defining at least one veto anode near an end portion of said central wire, and a primary charge detecting anode; and coupling means connected to each of said plurality of segments by which a biasing voltage may be applied to said segments and signals extracted therefrom.

2. An anode as defined in claim 1, wherein a segment is provided at each end portion of said central wire to define two veto anodes, and wherein a segment provided centrally along the length of said central wire defines said primary charge detecting anode.

3. An anode as defined in claim 2, wherein said insulating sleeve is broken at a location along said primary charge detecting anode, said electrically conductive coating making contact with said central wire at said location, and wherein said coupling means comprise conductors respectively connected to each veto anode, and a conductor connected to said central wire at an end thereof by which electrical contact is made to said primary charge detecting anode at said location of the broken insulation.

4. In a gas radiation counter, the improvement comprising a coaxial anode system by which undesirable background ionization interference may be suppressed, said system comprising:

an elongated central wire;
an electrically insulating sleeve disposed about said central wire;

a plurality of longitudinally discontinuous segments of an electrically conductive coating disposed about said insulating sleeve in coaxial relationship to and along the length of said central wire; said plurality of segments defining at least one veto anode near an end portion of said central wire, and a primary charge detecting anode;

means for applying a high voltage to each of said plurality of segments; and coupling means for connecting said primary charge detecting anode to detection circuitry in anti-coincidence with said veto anode.

5. The improvement defined in claim 4, wherein the same voltage is applied to each of said plurality of segments, whereby a substantially uniform electric field is produced along the length of said central wire.

6. The improvement defined in claim 5, wherein a segment is provided at each end portion of said central wire to define two veto anodes, and wherein a segment provided centrally along the length of said central wire defines said primary charge detecting anode.

7. The improvement defined in claim 6, wherein said insulating sleeve is broken at a location along said primary charge detecting anode, said electrically conduc-

7

tive coating making contact with said central wire at said location, and wherein said coupling means comprise conductors respectively connected to each veto anode, and a conductor connected to said central wire

8

at an end thereof by which electrical contact is made to said primary charge detecting anode at said location of the broken insulation.

* * * * *

5

10

15

20

25

30

35

40

45

50

55

60

65

