



NATIONAL AERONAUTICS AND SPACE ADMINISTRATION  
WASHINGTON, D.C. 20546

REPLY TO  
ATTN OF: GP

OCT 18 1973

TO: KSI/Scientific & Technical Information Division  
Attention: Miss Winnie M. Morgan

FROM: GP/Office of Assistant General Counsel for  
Patent Matters

SUBJECT: Announcement of NASA-Owned U.S. Patents in STAR

In accordance with the procedures agreed upon by Code GP and Code KSI, the attached NASA-owned U.S. Patent is being forwarded for abstracting and announcement in NASA STAR.

The following information is provided:

U.S. Patent No. : 3,760,708

Government or Corporate Employee : Government

Supplementary Corporate Source (if applicable) : \_\_\_\_\_

NASA Patent Case No. : MFS-21,136-1

NOTE - If this patent covers an invention made by a corporate employee of a NASA Contractor, the following is applicable:

Yes  No

Pursuant to Section 305(a) of the National Aeronautics and Space Act, the name of the Administrator of NASA appears on the first page of the patent; however, the name of the actual inventor (author) appears at the heading of column No. 1 of the Specification, following the words ". . . with respect to an invention of . . ."

*Elizabeth A. Carter*

Elizabeth A. Carter  
Enclosure  
Copy of Patent cited above



(NASA-Case-MFS-21136-1) CRYOGENIC  
GYROSCOPE HOUSING Patent (NASA) 10 p  
CSCI 201  
00/23 Unclas 28415  
N74-18323

[54] **CRYOGENIC GYROSCOPE HOUSING**  
 [75] Inventor: Wilhelm Angele, Huntsville, Ala.  
 [73] Assignee: The United States of America as represented by the Administrator of the National Aeronautics and Space Administration, Washington, D.C.

3,018,142 1/1962 Warnock, Jr. .... 308/9

Primary Examiner—Manuel A. Antonakas  
 Attorney—L. D. Wofford, Jr. et al.

[22] Filed: June 13, 1972

[21] Appl. No.: 262,430

[52] U.S. Cl. .... 74/5.7, 308/10

[51] Int. Cl. .... G01c 19/12

[58] Field of Search ..... 74/5.7, 5 R, 5.6;  
 308/DIG. 1, 9; 308/10

[57] **ABSTRACT**

A cryogenic gyroscope housing having gas spin-up means provided in annular discs inserted between housing shells. A circumferential recess in the inner edges of the discs at their juncture serves as the gas spin-up channel, and recesses in the discs at their junctures with the shells form suction channels. The discs also have inlet and outlet ports communicating with the spin-up channel and exhaust slots communicating with the suction channels. Mating surfaces of the discs and housing shells are held in position by optical contact at the equatorial plane of the housing. Suspension electrodes and thin-film readout loops are disposed in the shells. A centering band and clamp rings provide for proper alinement and placement of parts in formation of optical contact joints.

[56] **References Cited**  
**UNITED STATES PATENTS**

3,252,340	5/1966	Watt .....	74/5.7 X
3,535,941	10/1970	Fowler et al. ....	74/5.7 X
3,522,737	8/1970	Brenot .....	74/5.7
3,043,635	7/1962	Bard .....	308/DIG. 1
3,194,613	7/1965	Pierry et al. ....	308/9

10 Claims, 10 Drawing Figures

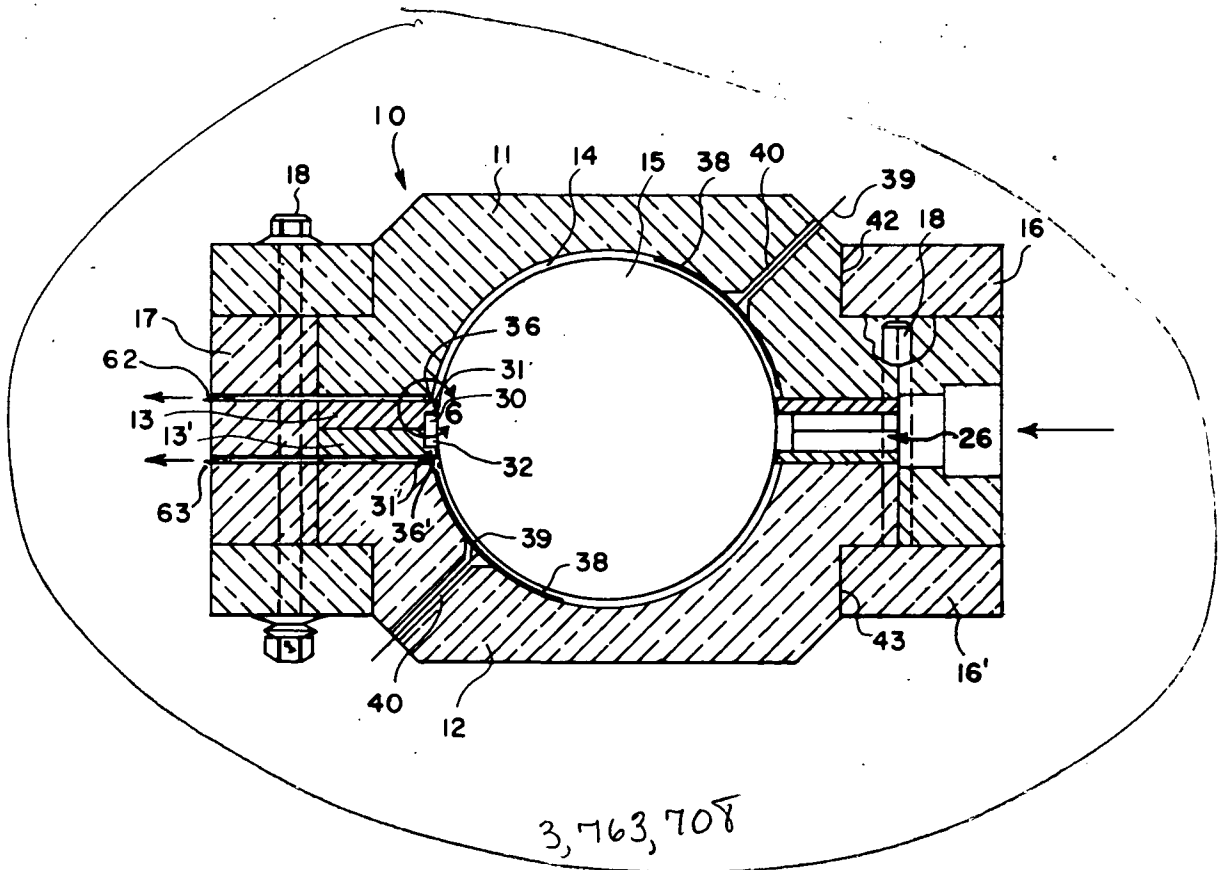

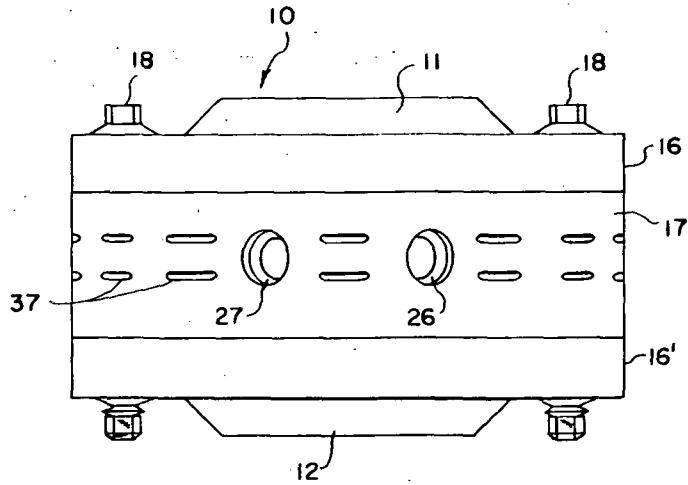

FIG. 1

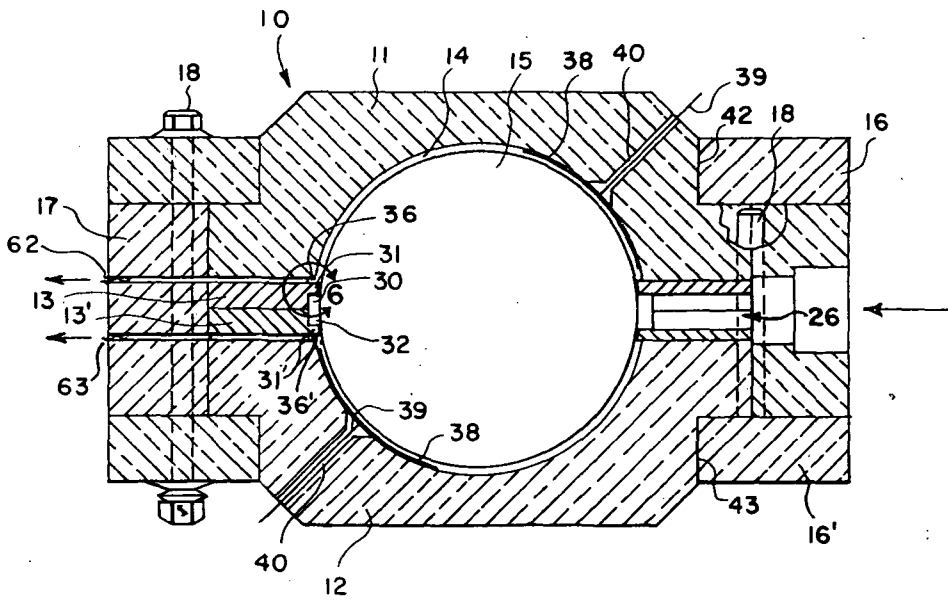

FIG. 2

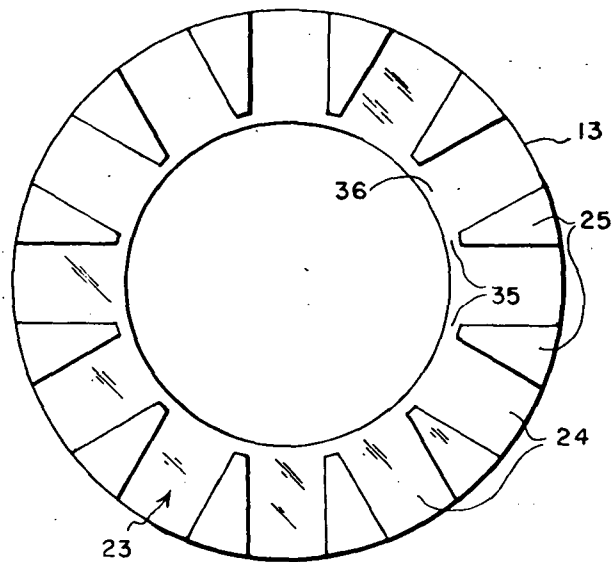

FIG. 4

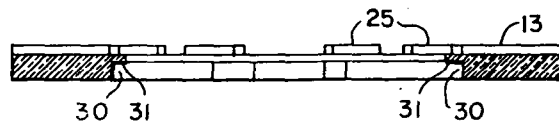

FIG. 5

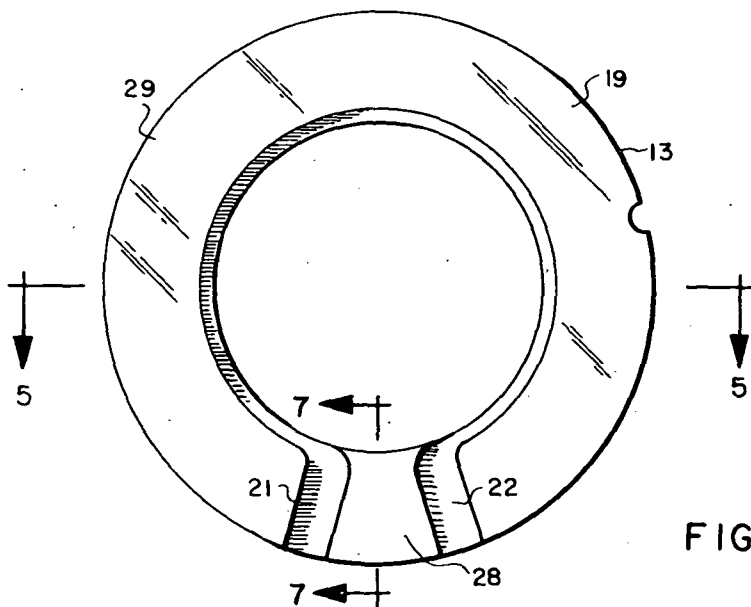

FIG. 3

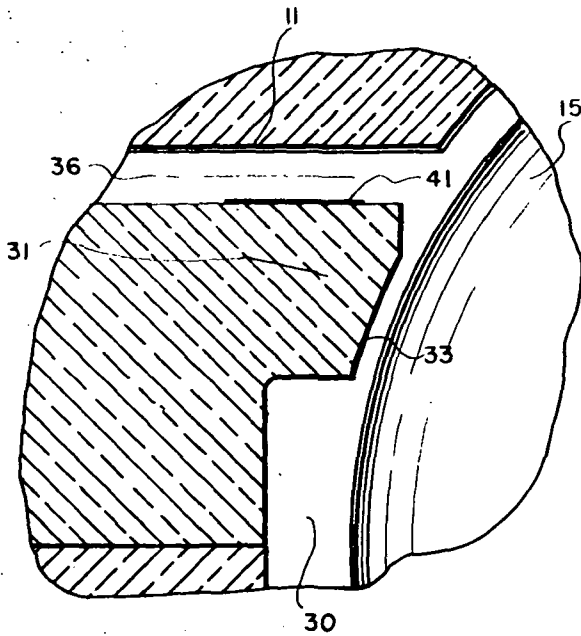

FIG. 6



FIG. 7

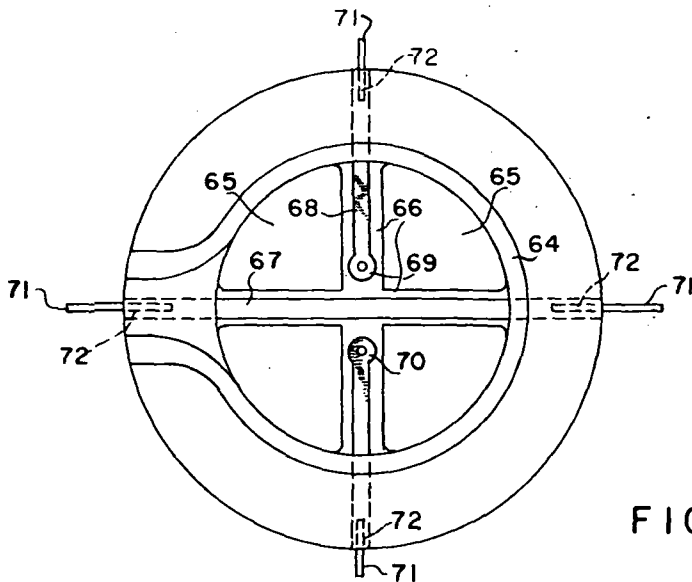

FIG. 10

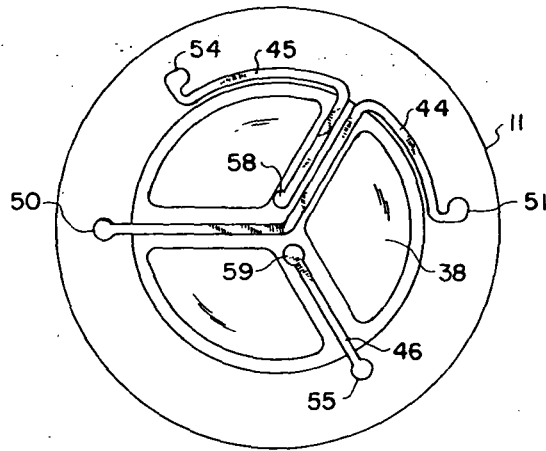

FIG. 8

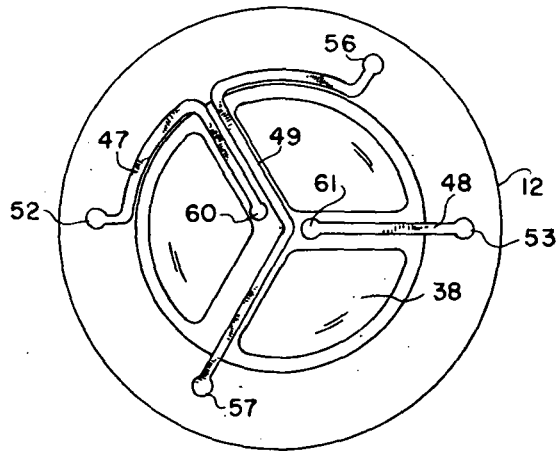

FIG. 9

**CRYOGENIC GYROSCOPE HOUSING****ORIGIN OF THE INVENTION**

The invention described herein was made by an employee of the United States Government and may be manufactured and used by or for the Government of the United States of America for governmental purposes without the payment of any royalties thereon or therefor.

**BACKGROUND OF THE INVENTION**

This invention relates to gyroscopes and more particularly to gyroscope housing assemblies.

Certain space applications require gyroscopes having a capability for making extremely precise measurements, for example, in experiments to determine relativistic precession by means of gyroscopes in an orbiting satellite, measurements on the order of only 0.05 arc-seconds per year are required. Such precision far exceeds the capability of conventional gyroscopes in which errors due to factors including bearing friction, gravitational effects and temperature are orders of magnitude higher than the value sought to be measured.

Cryogenic gyroscopes avoid most sources of error of conventional gyroscopes by use of a superconducting rotor and electrical field suspension, the rotor being spun and maintained at constant temperature by passage of a cryogen vapor. Operation of this type gyroscope is based on the magnetic moment generated by rotation of a superconducting body ("London moment.") By measuring magnetic flux through loops around the rotor, precession of the rotor spin axis can be determined with high precision.

While theoretical advantages of cryogenic gyroscopes are apparent, construction of a practical device has proven difficult, primarily because of the close tolerances required to be met in manufacture of housing parts. In previous approaches to design of housings for cryogenic gyroscopes, gas spin-up channels and suction grooves for rotation of the superconducting ball have been located in hemispherical shell members, along with suspension electrodes and readout loops. Formation of shell halves to exact hemispherical cavity dimensions has been a formidable problem, and attainment of tolerances in gas spin-up channels and suction grooves in arcuate surfaces of the shells has also presented difficulty. A simpler design, more amenable to high-precision manufacturing, is needed to realize the benefits of cryogenic gyroscopes.

**SUMMARY OF THE INVENTION**

In the present invention a cryogenic gyroscope housing is made up of two shells and two annular discs inserted between the shells, the discs being recessed to provide a gas spin-up channel and suction channels for rotation of a superconducting ball. The discs also have inlet and outlet ports communicating with the spin-up channel and auxiliary exhaust slots communicating with the suction channels. Suspension electrodes and readout loops are disposed within the housing shells, but gas spin-up means are located entirely in the discs. The difficulties encountered previously in preparation of exact half-spherical cavities and in formation of precise channels and grooves in arcuate shell surfaces are avoided by this means.

It is therefore an object of the invention to provide an improved housing assembly for cryogenic gyroscopes.

Another object is to provide a gyroscope housing assembly that is amenable to attainment of close tolerances in manufacturing.

Still another object is to provide a cryogenic gyroscope housing wherein gas spin-up means are located elsewhere than in electrode-holding hemispherical housing shells.

Other objects and advantages of the invention will be apparent from the following detailed description and the appended claims.

**BRIEF DESCRIPTION OF THE DRAWINGS**

In the drawings:

FIG. 1 is an elevation view of a gyroscope housing assembly embodying the invention;

FIG. 2 is a vertical sectional view of the housing assembly of FIG. 1;

FIG. 3 is plan view showing a spin-up disc with the inlet and outlet groove side upward;

FIG. 4 is a plan view showing a spin-up disc with the exhaust side upward;

FIG. 5 is a vertical sectional view taken along line 5—5 of FIG. 3;

FIG. 6 is an enlarged sectional view of the encircled area in FIG. 2 showing the inner edge of the major segment of a spin-up disc;

FIG. 7 is an enlarged sectional view of the inner edge area of the minor segment of a spin-up disc, taken along line 7—7 of FIG. 3;

FIG. 8 is an interior view, taken in the upward direction, of the upper housing shell member of FIG. 2;

FIG. 9 is an interior view, taken in the downward direction, of the lower housing shell member of FIG. 2; and

FIG. 10 is a schematic view, taken through the equatorial plane, of a housing embodiment wherein four electrodes are located in each shell.

**DESCRIPTION OF THE PREFERRED EMBODIMENT**

Referring to FIG. 1 and FIG. 2 of the drawings, the gyroscope housing assembly 10 includes upper housing shell 11, lower housing shell 12 and annular discs 13, 13' inserted between the shells, the shells and inner edges of the discs defining a generally spherical cavity 14 for rotation therein of a superconducting ball 15. Upper clamp ring 16 and lower clamp ring 16', disposed in annular recesses 42, 43 in the outer surface of shells 11 and 12, and centering band 17, disposed around the circumference of the housing at its equatorial zone, provide for precise alignment in bringing mating surfaces of the shells and discs into optical contact during assembly. Clamp rings 16 and 16' are secured together against edges of the centering band by means such as bolts 18. Except for bolts and electrical parts to be described below, the entire assembly is preferably made of quartz owing to its low thermal expansion and capability for being formed into parts having close tolerances and surfaces adapted for optical contact. Other materials having a near-zero thermal expansion can also be used.

Annular discs 13, 13' comprise flat washers having portions of their faces and inner edges removed to provide channels or passageways for cryogen vapor em-

ployed to spin the superconducting rotor. Discs 13 and 13' are identical to one another, each disc having one face 19 as shown in FIG. 3 with two radially extending recesses 21 and 22 and an opposite face 23 as shown in FIG. 4 with a plurality of radially extending grooves 24 and elevated portions 25 spaced apart around the entire face. The discs are adapted to be assembled with faces 19 in mating relation so that recesses 21 and 22 of the two discs are in alignment, forming inlet port 26 and outlet port 27. Recesses 21 and 22 are separated by a small segment 28 of face 19, the major flat segment 29 between the recesses extending around most of the circumference of the housing at the equatorial zone of the rotor. The inner edges of discs 13, 13' have, coextensive with major segment 29 a recess 30 extending from face 19 to a projecting shoulder 31 located adjacent face 23. Shoulders 31, 31' define a spin-up channel 32 which extends around most of the circumference of the housing and communicates with inlet port 26 and outlet port 27. As shown in FIG. 6, shoulder 31 extends slightly into the spherical housing cavity, and its inner edge 33 is rounded to provide an arcuate surface equidistant to rotor 15. The gap between the rotor and the housing is thus reduced at edge 33 in order to restrict the flow of cryogen vapor into the space between the rotor and housing shells and thus avoid electrical between the rotor and suspension electrodes. Coextensive with segment 28 between inlet port 26 and outlet port 27, the inner edges of discs 13, 13' have a smooth surface 34, as shown in FIG. 7, recesses 30, 30' at these segments being terminated in order to avoid back flow of cryogen vapor.

As shown in FIG. 4 and FIG. 5, face 23 of disc 13 has coplanar elevated portions 25 extending from the outer edge to a location corresponding to a circle concentric with and slightly larger than the inner edge; the recessed portions 35 inside the tips of elevated portions 25 defining a suction channel 36 extending around the circumference of the housing and communicating with the housing exterior through grooves 24 and apertures 37 in centering band 17. Any cryogen vapor that escapes between inner edge 33 of the spin-up channel and the rotor will be vented to external vacuum by this means, thus preventing buildup of pressure between the rotor and housing shells.

In the embodiment shown the assembled housing is maintained in position by means of optical contact joints between mating surfaces of the discs and housing shells. Optical contact, characterized by very strong surface adhesion based on Van Der Waals molecular forces, requires a high degree of flatness and smoothness in the mating surfaces. For the preferred material, quartz, a surface flatness of  $\lambda/30$  or better and parallel to one light band, which can be obtained by grinding and polishing, provides a surface condition suitable for optical contact. Vertical dimensions of the outside surfaces of the shells and discs should also be highly uniform, within a tolerance of about 10 micro-inches, to enable precise alignment within the centering band during assembly.

Suspension electrodes 38, in the form of generally triangular deposits of a thin film of conductive metal such as titanium or gold, are provided on the inner surface of housing shells 11 and 12. The electrodes are connected to a suitable servo control network (not shown) by means of wire conductors 39 disposed in apertures 40 which penetrate the housing shell. In the embodiment

shown in FIGS. 2 through 9, housing shells 11 and 12 each carry three electrodes arranged so that their three axes intersect one another at an angle of 90°. Additional electrodes or other spacing arrangements can be used.

Readout signals for determination of gyroscope precession in three-dimensions are obtained from three readout loops encircling the rotor in the housing. The loops may take the form of a thin, narrow deposit of a superconducting metal such as niobium. One loop 41 is situated near the equatorial zone of the housing at the base of suction channel 36 on disc 13. The remaining two loops are made up of segments carried by the housing shells as shown in FIGS. 8 and 9 and jumper wires connecting ends of these segments. One of the latter two loops is made up segment 44 in housing shell 11 and segments 47 and 48 in housing 12, with segment terminals 50 and 52 and 51 and 53, respectively, being connected across discs 13, 13' by jumper wires (not shown). The other loop includes segments 45 and 46 in housing shell 11 and segment 49 in housing shell 12, along with jumper wires for connecting of terminal 54 to 56 and 55 to 57. Electrical isolation of the loops from one another is provided by interruption of one loop at its intersection with the other, with the resulting segment ends being connected by jumper or by-pass means. Thus terminals 58 and 59 in housing shell 11 are connected to one another by a jumper wire (not shown) and terminals 60 and 61 in housing shell 12 are similarly connected. Isolation can also be provided by depositing one loop segment to pass over the other, after depositing an intervening thin layer of insulating material such as silicon dioxide by sputtering. External connections to readout loops may take the form of metal spring contacts disposed within vacant spaces in inlet and outlet parts or exhaust grooves in the spin-up discs. Spring contacts 62 and 63 for loop 41 are shown in FIG. 2, extensions of loop 41 being disposed radially at the base of grooves 24 so as to be present surfaces for making electrical connection with the contacts. The remaining two loops are similarly connected to contacts disposed in exhaust grooves.

FIG. 10 shows an alternate embodiment for placement of suspension electrodes and readout loops. In this embodiment each housing shell 64 carries four suspension electrodes 65 deposited in quadrants of the shell surface so that two open band 66 intersect at the polar regions. Readout loops are disposed symmetrically within the open bands, one loop 67 extending across the pole and the other loop 68 being interrupted at terminals 69 and 70, joined by a jumper wire (not shown) so as to be electrically isolated from loop 67. A third loop in this arrangement is located in the suction channel of a spin-up disc as in the embodiment discussed above. Loop terminals are connected electrically to external wires 71 by means of spring contacts 72 located in exhaust spaces of the spinup discs. Loop terminals of the housing shell shown are also connected across the spinup discs to corresponding terminals of the other housing shell of the assembly (not shown) by means of suitable jumper wires (not shown). The four-electrode arrangement provides for symmetrical disposition of loops in each plane.

For operation under zero-gravity conditions in space, a solid rotor of quartz or other near zero expansion, non-magnetic material can be employed in combination with the housing described above. The space envi-



ronment also provides the external vacuum required for gyroscope operation. Within the earth's atmosphere and under the influence of normal gravity certain modifications and additional features may be needed. In order to facilitate electrical field suspension development, a hollow, lightweight rotor is preferred for use where the gyroscope is subject to the earth's gravitational field, and provision of an external vacuum is necessary for atmospheric operation.

It will be apparent to one skilled in the art that various other changes and modifications to the embodiments described above can be made without departing from the invention.

What is claimed is:

1. A gyroscope housing assembly comprising a pair of housing shells and a pair of recessed annular discs adapted to be inserted in face-to-face relation between said shells, the inner surfaces of said shells and the inner edges of said discs forming a generally spherical cavity and having a super-conducting ball rotatably mounted therein, each of said discs having in its inner edge at its juncture with the other of said discs a recess extending round a major segment thereof and coextensive therewith a projecting shoulder extending slightly into said spherical cavity, said recesses and shoulders defining a gas spin-up channel extending around most of the circumference of said ball, gas inlet and outlet ports communicating with said spin-up channel and exhaust means communicating the space in said cavity outside of said spin up channel with an external vacuum.

2. The housing assembly of claim 1 including in the faces of said discs opposite to the faces in contact with

one another a circumferential recess at the juncture thereof with said housing shells and a plurality of radially extending grooves communicating said circumferential recess with the exterior of said assembly.

3. The housing assembly of claim 2 wherein said inlet and outlet ports comprise a pair of mating, radially extending grooves spaced in close proximity in the faces of said discs that are in contact with one another.

4. The housing assembly of claim 3 including in the minor segment of the inner edges of said discs between the inlet and outlet grooves an unrecessed portion spaced close to said ball and adapted to prevent back flow of spin-up gas.

5. The housing assembly of claim 4 including a plurality of thin film suspension electrodes disposed on the inner surfaces of said shells.

6. The housing assembly of claim 5 including at least one thin film conductive metal readout loop carried by said assembly and encircling the circumference of said ball.

7. The housing assembly of claim 6 wherein a metal readout loop is disposed in the circumferential recesses of one of said discs.

8. The housing assembly of claim 1 wherein said housing shells and discs are made of quartz.

9. The housing assembly of claim 8 wherein mating surfaces of said housing shells and discs are maintained in position by means of optical contact joints.

10. The housing assembly of claim 9 wherein mating surfaces of said housing shells and discs have a surface flatness of  $\lambda/30$  or better and parallel to one light band.

\* \* \* \* \*

35

40

45

50

55

60

65