

Mars hall



NATIONAL AERONAUTICS AND SPACE ADMINISTRATION
WASHINGTON, D.C. 20546

REPLY TO
ATTN OF: GP

NOV 5 1973

TO: KSI/Scientific & Technical Information Division
Attention: Miss Winnie M. Morgan

FROM: GP/Office of Assistant General Counsel for
Patent Matters

SUBJECT: Announcement of NASA-Owned U.S. Patents in STAR

In accordance with the procedures agreed upon by Code GP and Code KSI, the attached NASA-owned U.S. Patent is being forwarded for abstracting and announcement in NASA STAR.

The following information is provided:

U.S. Patent No. : 3,765,229

Government or Corporate Employee : Government

Supplementary Corporate Source (if applicable) : _____

NASA Patent Case No. : MFS-29335-1

NOTE - If this patent covers an invention made by a corporate employee of a NASA Contractor, the following is applicable:

Yes No

Pursuant to Section 305(a) of the National Aeronautics and Space Act, the name of the Administrator of NASA appears on the first page of the patent; however, the name of the actual inventor (author) appears at the heading of column No. 1 of the Specification, following the words ". . . with respect to an invention of . . ."

Elizabeth A. Carter

Elizabeth A. Carter
Enclosure
Copy of Patent cited above

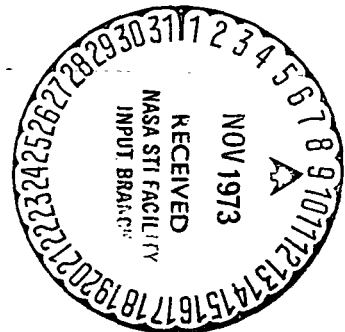

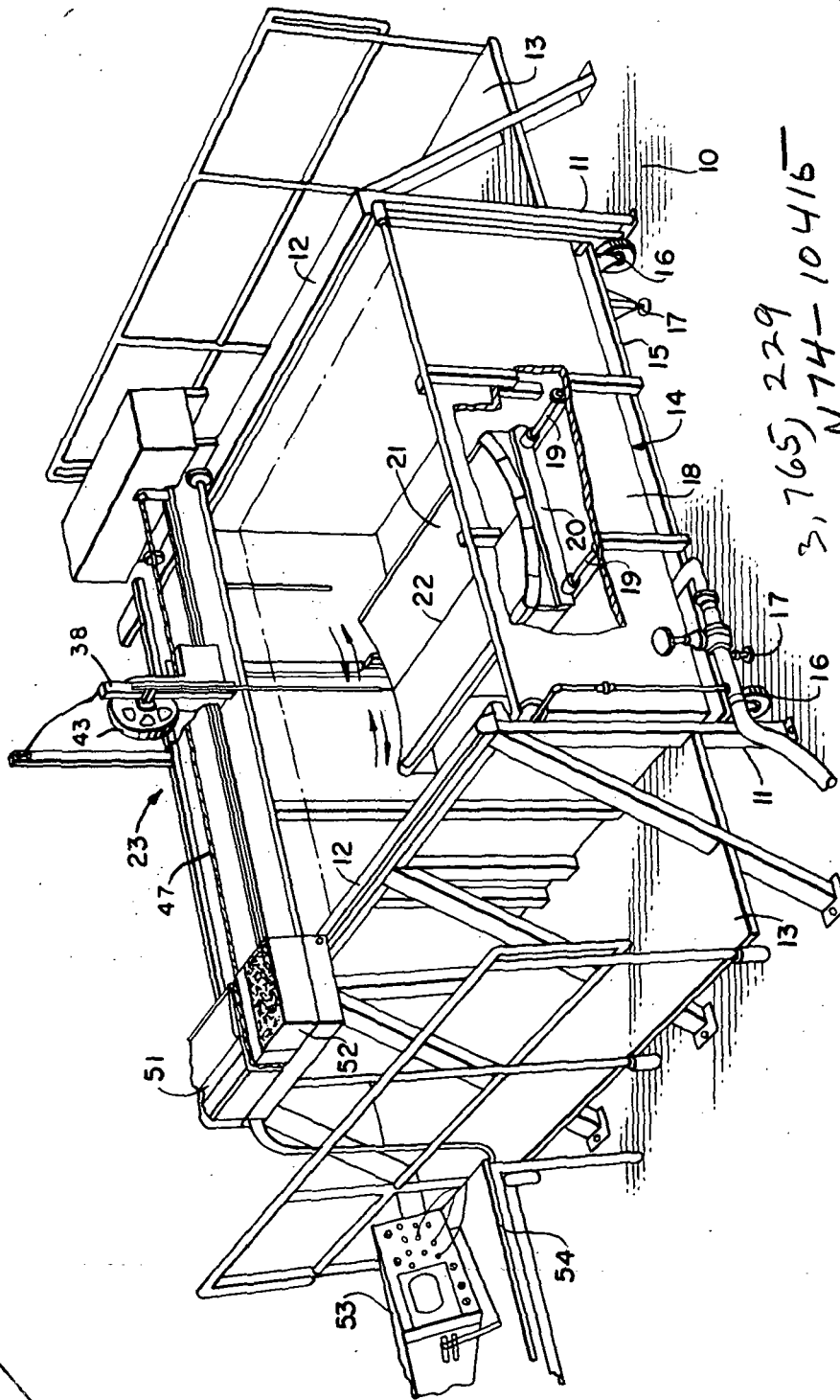

FIG. 1.

3,765,229
N 74-10415

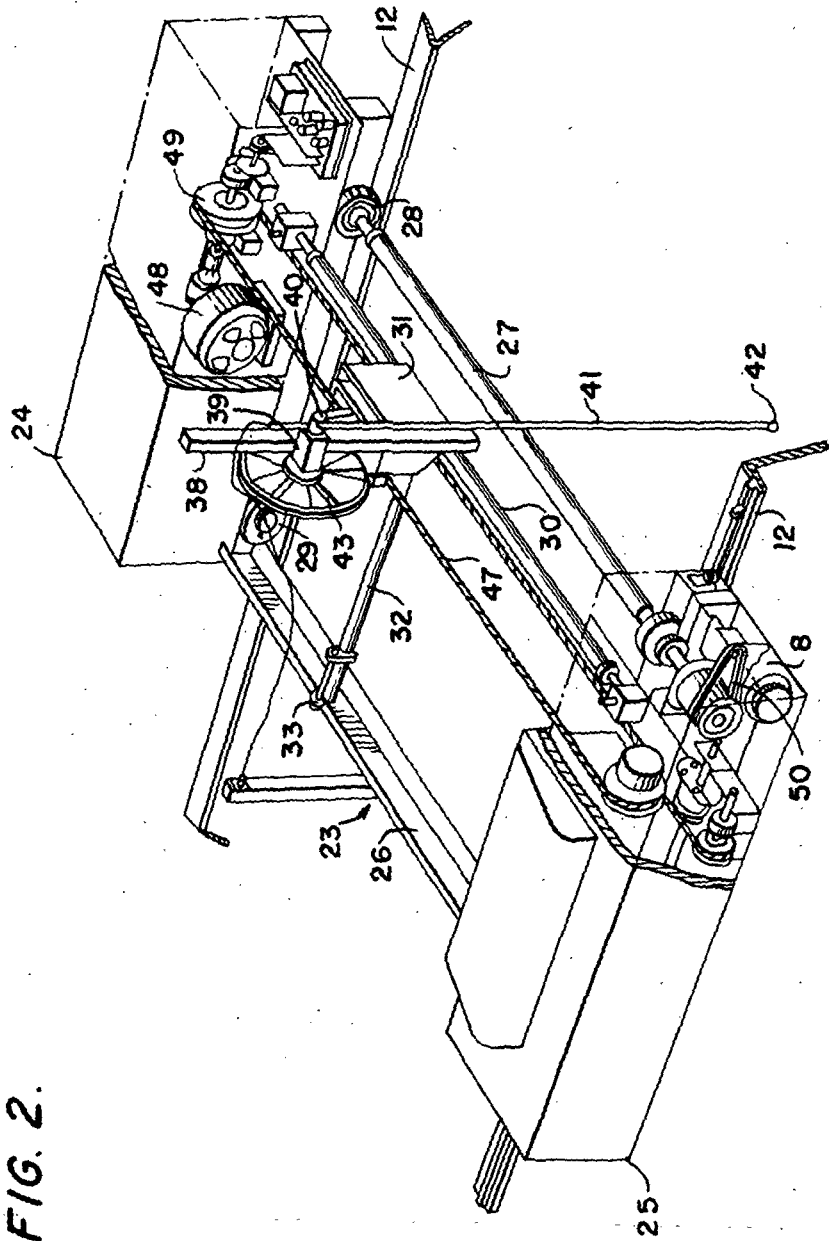

FIG. 2.

FIG. 3.

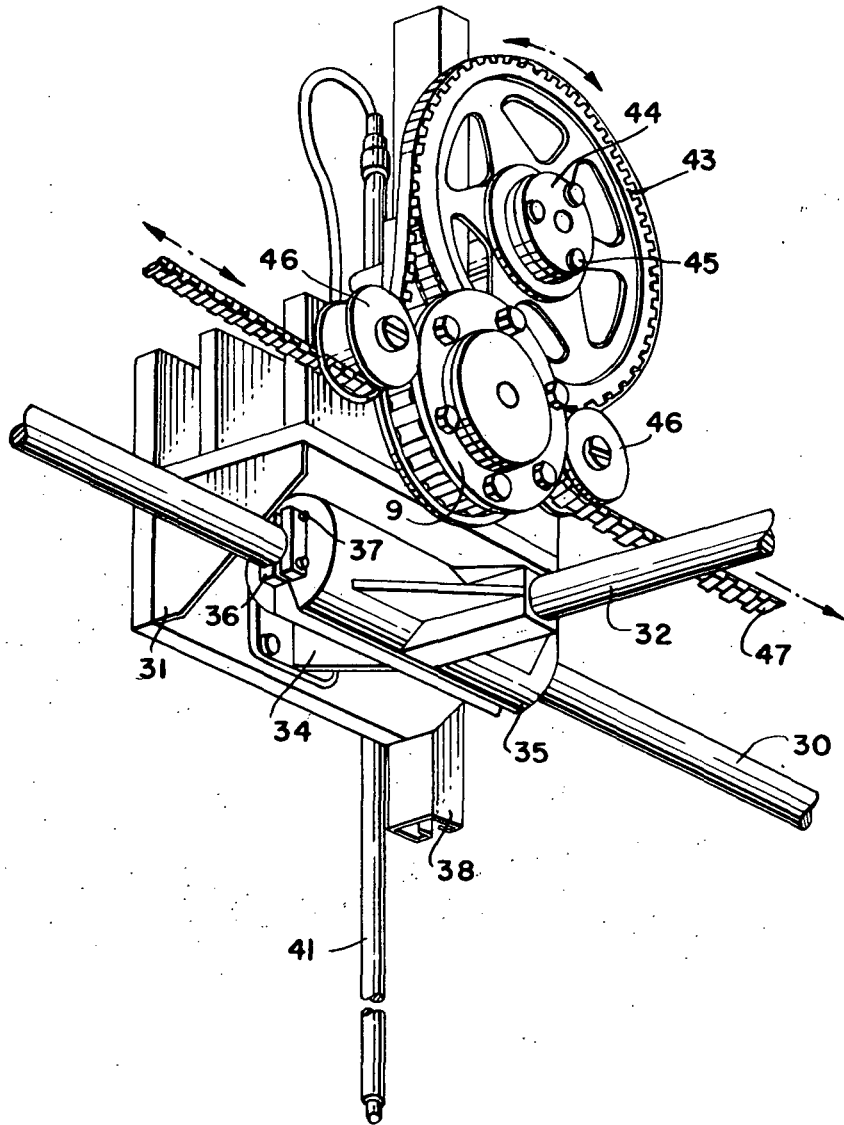

FIG. 4.

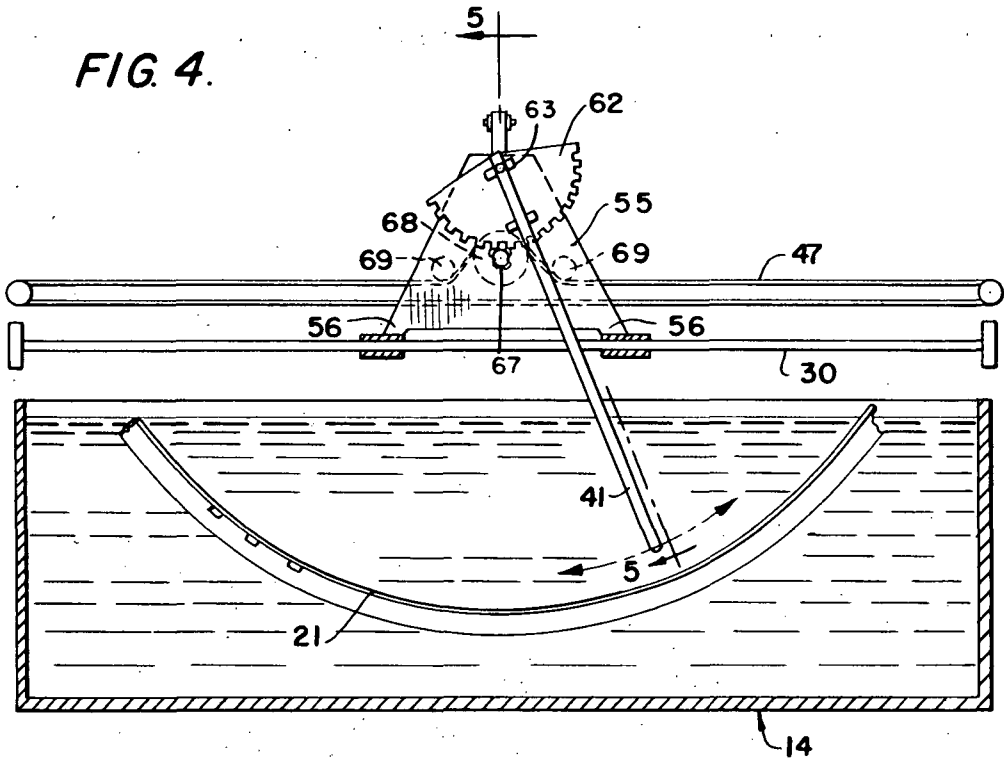

FIG. 6.

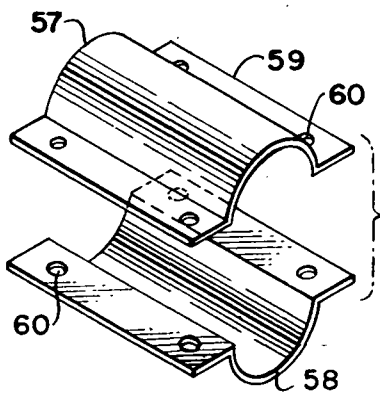

FIG. 5.

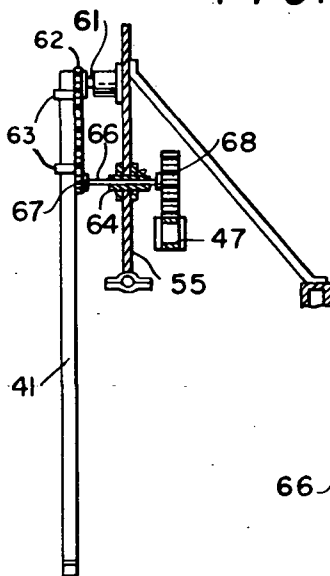
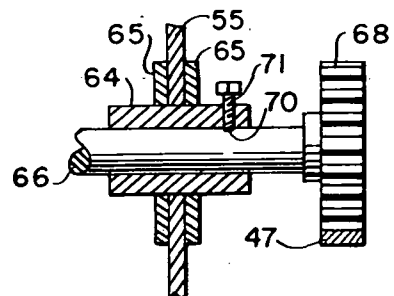

FIG. 7.



[54] **ULTRASONIC SCANNER FOR RADIAL AND FLAT PANELS**

[75] Inventors: **Robert L. Spencer; Ewing K. Hill,** both of Huntsville, Ala.

[73] Assignee: **The United States of America as represented by the Administrator of the National Aeronautics and Space Administration, Washington, D.C.**

[22] Filed: **Mar. 27, 1972**

[21] Appl. No.: **238,263**

[52] U.S. Cl. **73/67.8 S**

[51] Int. Cl. **G01n 29/04**

[58] Field of Search..... **73/67.8 S, 67.9, 73/71.5 U, 67.8 R**

[56] **References Cited**

UNITED STATES PATENTS

3,480,002 11/1969 Flaherty et al. **73/67.9 UX**

OTHER PUBLICATIONS

A. P. Rogel et al, A New Concept in Immersion Ultrasonics, Materials Evaluation, May 1968, p. 83-89.
Curtis-Wright Trade Bulletin, Ultrasonic Testing Sys-

tems, First Six Sheets.

Primary Examiner—Richard C. Queisser
Assistant Examiner—John P. Beauchamp
Attorney—L. D. Wofford, Jr. et al.

[57] **ABSTRACT**

This specification discloses an ultrasonic scanner that is adapted to scan flat or radial panels which are of a honeycomb structure or include welded seams. The apparatus includes a bridge support in the form of a pair of spaced rails, a travelling bridge movable on the rails, a carriage that is either locked in a fixed position on the bridge or is reciprocal therealong, a tubular arm depending from the bridge and having a search unit at its lower end, mechanism on the carriage to oscillate the arm when the carriage is in fixed position, clamping means to lock the carriage in position on the bridge, and a detachable lock for rendering the oscillating mechanism inoperable, said clamping means and lock being selectably usable, one to the exclusion of the other depending on the type of panel to be scanned.

10 Claims, 7 Drawing Figures

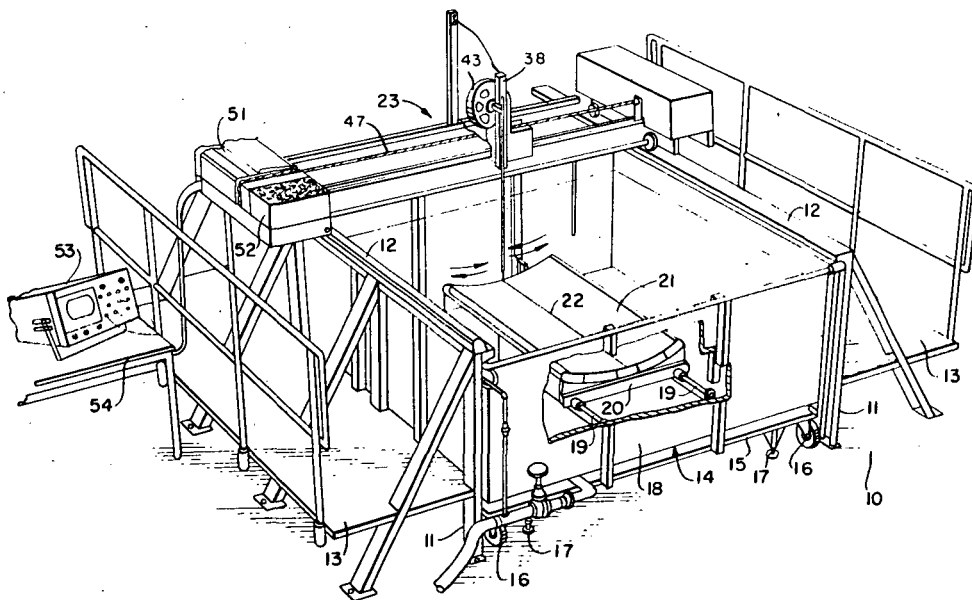

(NASA-Case-MFS-20335-1) **ULTRASONIC SCANNER FOR RADIAL AND FLAT PANELS**
Patent (NASA) 8 p

N74-10415

CSCL 14B

Unclas

00/14 20123

ULTRASONIC SCANNER FOR RADIAL AND FLAT PANELS

ORIGIN OF THE INVENTION

The invention described herein was made by employees of the U.S. Government and may be manufactured and used by or for the Government for governmental purposes without the payment of any royalties thereon or therefor.

BACKGROUND OF THE INVENTION

The present invention relates to ultrasonic scanning mechanism that is used to scan honeycomb panels or panels having welded seams and is concerned primarily with mechanism, which by a simple adjustment is adapted to scan either a radial (curved) panel or a flat panel. At the present time ultrasonic scanning devices which are used for medical diagnostic purposes on the human body and which are capable of linear movement in a plane and oscillating arcuate movement are known. It is also known to scan a workpiece including a weld seam. However, the known devices for this purpose include search units which are capable of movement in a plane and not with an oscillating arcuate movement.

OBJECTS OF THE INVENTION

With the foregoing in mind the present invention has in view the following objectives.

1. To provide ultrasonic scanning apparatus which is susceptible, by simple adjustments, to adapt it to the scanning of either a radial panel or a flat panel.

2. To provide, in apparatus of the type noted, an immersion tank including a workpiece holder that is adapted to receive, and hold in position for scanning, a panel which is either flat or radial.

3. To provide, in apparatus of the character aforesaid a travelling bridge on which is mounted a carriage that is either movable along the bridge or locked in a position thereon.

4. To provide, in apparatus of the kind described, a tubular arm which depends from the carriage into the immersion tank and which carries a search unit at its lower end together with mechanism to oscillate the arm when the carriage is fixed on the bridge.

5. To provide, in apparatus of the types noted, clamping means for holding the carriage in fixed position on the bridge, and,

6. To provide, in apparatus of the character aforesaid a detachable lock which renders the oscillator mechanism inoperative when the carriage is movable on the bridge.

SUMMARY OF THE INVENTION

The foregoing objects are achieved by providing a supporting structure presenting a pair of rails. An immersion tank is positioned between the rails and below their level. A work piece holder is mounted in the tank and is adapted to hold either a radial or flat panel. A travelling bridge is movable along the rails and a carriage is mounted on the bridge. Depending from the carriage and into the tank is a tubular arm having a search unit at its lower end. Mechanism is provided on the carriage to oscillate the arm to impart arcuate movement to the search unit. Clamping means holds the carriage against movement when the oscillating mechanism operates. A lock is associated with the os-

cillating mechanism to render it ineffective when the carriage reciprocates on the bridge.

For a full and more complete understanding of the invention, reference may be had to the following description and accompanying drawings wherein:

FIG. 1 is a perspective of those portions of an ultrasonic scanning apparatus which are essential to a disclosure of the present invention.

FIG. 2 is a perspective of portions of the apparatus of FIG. 1 with parts broken away.

FIG. 3 is a detailed perspective of the oscillating mechanism taken from the rear.

FIG. 4 is a transverse vertical section through the immersion tank with certain elements of a modified oscillating mechanism thereabove shown in elevation and isolated or unsupported.

FIG. 5 is a detailed section through portions of the oscillating mechanism, being taken on a plane normal to the showing of FIG. 4 and about in the planes of the lines 5—5 of FIG. 4.

FIG. 6 is a detailed perspective depicting the elements of a removable abutment in exploded relation.

FIG. 7 is a detailed section on an enlarged scale through a portion of the mechanism of FIG. 5.

Referring now to the drawings, and first more particularly to FIG. 1 a foundation or floor on which the subject apparatus is mounted is shown at 10. Upstanding from floor 10 are a pair of posts 11 at the front and another pair (not illustrated) at the rear. Mounted on the upper ends of these posts are a pair of rails 12. Supported from posts 11 and rails 12 by the structure illustrated but the elements of which are not identified by reference characters are catwalks 13.

An immersion tank, which is necessary for ultrasonic scanning is designated generally at 14. It includes a bottom 15 from which depend casters 16 which impart mobility to the tank. Tank 14 is of rectangular shape and is dimensioned to fit in the space between rails 12 and below their level. After tank 15 has been properly positioned jacks 17 are operated so that their feet engage floor 10 to fix the position of tank 10.

Tank 10 includes front and rear walls, the front wall being shown at 18 and extending between these walls are a pair of spaced guide rods 19. Adjustable on rods 19 is a work holder 20. The latter is provided with a device, the details of which are not illustrated for holding and securing in position a panel to be scanned. In FIG. 1 this panel is shown at 21 as radial and having a weld seam 22. A flat panel (not illustrated) can be secured in work holder 20 when it is to be scanned.

A travelling bridge is identified in its entirety at 23 and is movable along rails 12. Referring now to FIG. 2 bridge 23 comprises a housing 24 at one side and laterally outside of the rail 12 at that side and a second housing 25 similarly positioned on the other side. Extending between housings 24 and 25 at the rear is a channel bar 26. Extending between housings 24 and 25 at the front is a drive shaft 27 which carries drive rollers 28 which ride on rails 12. Additional rollers 29 support the rear ends of housings 24 and 25 on rails 12. Also extending between housings 24 and 25 is a guide rod 30. A carriage 31 is either reciprocal on guide rod 30 or is clamped in a fixed position thereon by mechanism to be later described. Extending rearwardly from carriage 31 is a support bar 32 the rear end of which carries a roller 33 that rides on the upper flange of channel bar 26.

Referring now to FIG. 3 which is a perspective taken from the rear of carriage 31 the latter is shown as having a bracket 34 projecting rearwardly therefrom. Mounted on bracket 34 is a clamping sleeve 35 which is split as illustrated and has a bore that received guide rod 30. On each of the two parts defined by the split a block 36 is secured. Screw bolts 37 pass through openings in one block 36 and are screwed into threaded sockets in the other block. Thus bolts 37 may be tightened to clamp sleeve 35 to rod 30 and hold carriage 31 in fixed position thereon or loosened to permit of reciprocation of carriage 31.

Mounted on the front face of carriage 31 is a vertical bar 38 which appears in FIG. 2. Carried by bar 38 at one side is a bearing block 39. Journalled in bearing 39 is a shaft 40 an end of which projects beyond the front face of bearing 39. A tubular arm 41 which preferably is sectional to permit of adjustment of its effective length is secured to the end portion of shaft 40 by being received in a passage therein. The lower end of arm 41 carries a search unit represented at 42.

As shown in FIG. 2 shaft 40 also extends beyond the rear face of bearing 39. Mounted on the rear end of shaft 40 is a toothed pulley 43. Referring now again to FIG. 3 pulley 43 includes a hub 44. When pulley 43 is to rotate on shaft 40 hub 44 is freely rotatable thereon. However, lock screws 45 are provided on hub 44 to lock pulley 43 against rotation during one mode of operation to be later described. The locking effect is achieved by screwing lock screws 45 inwardly so that they are received in sockets (not illustrated) in the rear face of bearing block 39.

Mounted on the rear face of carriage 31 are a pair of idler pulleys 46 and between idlers 46 is a belt positioning pulley 9 that is rotatably mounted on the rear face of carriage 31. Referring now to FIG. 2 an endless drive belt 47 is shown as extending between housings 24 and 25.

Back again to FIG. 3 the top ply of belt 47 is shown as passing beneath and around idlers 46 and over pulley 43 and held in engagement with these pulleys by pulley 9. Thus as belt 47 is driven with a reciprocating movement, and with pulley 43 free to rotate on shaft 41, the latter is oscillated with search unit 42 moving in an arcuate path.

FIGS. 1 and 2 are somewhat diagrammatical and lack certain details shown in FIG. 3. For example, the idler pulleys 46 and belt positioning pulley 9 are shown only in FIG. 3. FIG. 3 also shows in detail how the belt 47 goes around pulleys 43 and 46. For the sake of simplicity, in FIGS. 1 and 2, vertical bar 38 is shown as a solid bar; it is actually a channel bar as shown in FIG. 3.

As shown in FIG. 2 a motor 48 is included in housing 24 and its drive shaft is operatively connected to drive pulley 49. Belt 47 passes over pulley 49 and is driven thereby. It is important to note that motor 47 operates with a periodic reversal. Thus it is effective to impart a reciprocating movement to the upper ply of belt 47. Housing 25 contains a motor 8 which is directly connected to drive shaft 27 by belt 50. Associated with motor 8 are controls which cause it to operate periodically so as to advance travelling bridge 23 with increments of movement or step by step.

As shown in FIG. 1 a recorder unit 51 is illustrated diagrammatically as mounted on one end of bridge 23 as is a control console 52. A reflectoscope 53 is de-

icted as supported on a table 54 at one side of a catwalk 13.

Details of recorder unit 51, console 52 and reflectoscope 53, as well as the controls for motors 48 and 8 are not disclosed because such devices are well known and available to the public.

OPERATION

When a radial panel, such as that shown at 21 in FIG. 1 is to be scanned, bolts 37 are tightened to clamp sleeve 35 to rod 30. Carriage 31 is now fixed in a position that is central of panel 21. Motor 48 is now operated to impart reciprocal movement to the upper ply of belt 47. This imparts an oscillating movement to pulley 43 which is transmitted to arm 41 by shaft 40. Search unit 42 is now moved over the inner face of panel 21 with an arcuate movement. After a complete pass of search unit 42 motor 8 advances bridge 23 one increment of movement. It is so advanced after each pass of search unit 42 until panel 21 is completely scanned.

When a flat panel is to be scanned bolts 37 are loosened to release sleeve 35 from its clamping position on rod 30 to permit carriage 31 to reciprocate on said rod. Lock screws 45 are tightened to lock pulley 43 against rotation, as belt 47 is reciprocated carriage 31 will move back and forth on rod 30 and as it does so arm 41 and search unit 42 are reciprocated with a rectilinear movement. After each pass of unit 42, bridge 23 is advanced one step as above described until the panel is completely scanned.

The Modification

A modified form of mechanism for oscillating arm 41 and clamping carriage 31 against movement on rod 30 is illustrated in FIGS. 4, 5, 6 and 7.

Mounted on carriage 31 is a plate 55 of the segmental shape illustrated. The lower or wide end of plate 55 is formed with legs 56 to each of which is attached an element 57 (FIG. 6) of a two part clamp. Each clamp includes a second element 58 which is complementary to element 57 and which cooperates therewith to define a bore that receives rod 30. Clamping elements 57 and 58 have flanges 59 formed with apertures 60. When the clamps are in effective positions apertures 60 on the flanges of one element align with the apertures on the flanges of the other element and bolts are passed through the aligned apertures. Nuts on the bolts secure the clamping relation of elements 57 and 58 on rod 30 to hold plate 55, and carriage 31 in a fixed position on rod 30.

Outstanding from the front face of plate 55 is a stub shaft 61 (FIG. 5). Journalled on shaft 61 is a gear segment 62. Arm 41 is secured to the front face of gear 62 by brackets 63 and depends therefrom into tank 14.

Referring now to FIGS. 5 and 7, a bearing 64 is mounted in plate 55 and secured in position by retaining plates 65. A shaft 66 is journalled in bearing 64 and drivably mounted on one end thereof is a pinion 67. The latter meshes with gear segment 62. Drivably carried by the other end of shaft 66 is a gear 68. The upper ply of drive belt 47 passes over gear 68 as shown in FIG. 4 and is guided in this direction by idler pulleys 69.

Referring now to FIG. 7 shaft 66 is shown as formed with a socket 70. Screwed into a threaded passage in bearing 64 is a set screw 71 the inner end of which fits in socket 70 when shaft 66 is located angularly in

proper relation thereto. When so positioned set screw 71 precludes rotation of shaft 66 and hence oscillation of gear segment 62 and arm 41 mounted thereon.

Operation of the Modification

When a radial panel is to be scanned the two clamps 57-58 on each leg 56 are clamped to rod 30. Thus carriage 31 is locked in a fixed position on rod 30 and which position is central of radial panel 21. Set screw 71 is released from shaft 66 so that the latter is driven by belt 47 with a periodic reversal of movement as above described. Thus arm 41 is oscillated to impart movement on an arcuate path to search unit 42 on the end thereof. After each complete pass of unit 42 the travelling bridge is advanced one increment of movement as above described.

When a flat panel is to be scanned clamping elements 57 and 58 are loosened which permits carriage 31 to reciprocate on rod 30. Set screw 71 is now threaded home so that its inner end is received in socket 70. This locks shaft 66, and the mechanism connected thereto against rotation. Socket 70 is so located that when shaft 66 is locked against rotation, arm 41 will be in a vertical position.

As the top ply of belt 47 is operated by motor 48 in the manner above described, carriage 31 and arm 41 mounted thereon will reciprocate on rod 30 to cause search unit 42 to make a complete pass over the panel being scanned. After each such pass bridge 23 is advanced one step and this operation repeated until the panel is scanned.

While preferred specific embodiments of the invention are hereinbefore set forth, it is to be clearly understood that the invention is not to be limited to the exact constructions, mechanisms, and devices illustrated and described because various modifications of these details may be provided in putting the invention into practice.

What is claimed is:

- I. In ultrasonic scanning apparatus for scanning either a radial or a flat panel,
 - a. a foundation
 - b. supporting structure upstanding from said foundation
 - c. a pair of rails on said supporting structure in spaced parallel relation
 - d. an immersion tank on said foundation between and below the level of said rails
 - e. a work holder in said tank and including a device for holding either a radial panel or a flat panel in position for scanning
 - f. a travelling bridge movable on said rails and spanning the distance therebetween, said bridge including a transverse guide rod
 - g. a carriage movable on said bridge along said guide rod
 - h. a tubular arm depending from said carriage into said tank and having a search unit at its lower end
 - i. mechanism on said carriage to oscillate said arm to

move said search unit over an arcuate path
j. a transverse drive belt on said bridge and operably connected to said oscillating mechanism

k. power means on said bridge to impart a reciprocal movement to said drive belt

l. clamping means on said carriage to clamp said carriage in a fixed position on said guide rod, and
m. locking means associated with said oscillating mechanism to render it inoperative

10 said clamping means and said locking means being selectively usable, one to the exclusion of the other whereby said carriage is clamped to said guide rod while the oscillating mechanism is operable or the carriage is reciprocal along said guide rod when the oscillating mechanism is locked against operation.

2. The apparatus of claim 1 in which the tank is mobile together with means for fixing the tank in an adjusted position relative to the rails.

3. The apparatus of claim 1 in which the oscillating mechanism comprises a pulley journaled on the carriage and in driving engagement with said drive belt.

4. The apparatus of claim 3 in which the locking means comprises a lock which holds the pulley against rotation relative to the carriage.

5. The apparatus of claim 3 together with idler pulleys on the carriage for maintaining the drive belt in engagement with the pulley.

6. The apparatus of claim 1 in which the clamping means comprises a split sleeve on the carriage and receiving the guide rod, and means to clamp the sleeve to the guide and to hold the carriage in a fixed position thereon.

7. The apparatus of claim 1 in which the oscillating mechanism comprises a vertical plate on the carriage, a segmental gear pivotally mounted on said plate and carrying said arm, a shaft journaled in said plate, a pinion on one end of said shaft meshing with said segmental gear and a gear on the other end of said shaft and in driving engagement with said drive belt, with the locking means being effective to hold said shaft against rotation, said plate including a pair of clamps to fix the position of the plate on said rod.

8. The apparatus of claim 7 in which the shaft is journaled on a bearing in said plate and the locking means comprises a set screw mounted on the bearing and engageable with the shaft to lock it against rotation.

9. The apparatus of claim 7 in which the plate is of segmental shape with the wider end being formed with a pair of spaced feet, and each clamp is carried by a foot and comprises a pair of complementary clamping elements and nuts and bolts for drawing said elements together.

10. The apparatus of claim 1 in which the bridge includes a transverse bar spaced from and parallel to said guide rod, together with a supporting rod having one end secured to the carriage and a roller on its other end riding on said transverse bar.

* * * * *