

NASA TECH BRIEF

Marshall Space Flight Center



NASA Tech Briefs announce new technology derived from the U.S. space program. They are issued to encourage commercial application. Tech Briefs are available on a subscription basis from the National Technical Information Service, Springfield, Virginia 22151. Requests for individual copies or questions relating to the Tech Brief program may be directed to the Technology Utilization Office, NASA, Code KT, Washington, D.C. 20546.

Acoustic-Optic Deflector Telescope

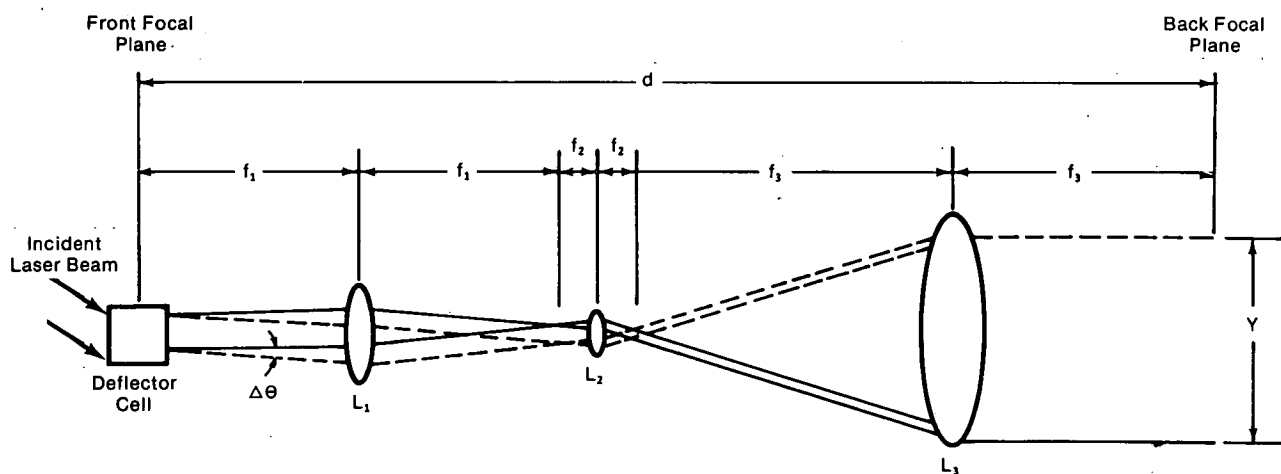

Three-Lens Deflector System

The problem:

In the construction of page-organized holographic memories, it is necessary to provide a collimated laser beam which can be deflected parallel to itself. This is used for selecting stored holograms from a two-dimensional array.

A typical deflector system is a single-lens type which includes an acoustic-optic deflector cell and a collimating lens. The cell bends the incoming laser beam at a predetermined angle to make it incident on the desired hologram. The lens between the cell and the array collimates the beam. One disadvantage of this system is its long optical path. In a typical setup, the path between the cell and the storage array is 27 m long.

The solution:

A three-lens system significantly reduces the optical path length.

How it's done:

The effective focal length (EFL) of the three-lens system, as shown in the illustration, is given by

$$EFL = f_1 f_3 / f_2$$

where f_1 , f_2 , and f_3 are the focal lengths of lenses L_1 , L_2 , and L_3 , respectively. Lens L_1 , with a focal length f_1 that is much smaller than the required EFL of the system, produces in its back focal plane a small pattern of deflected spots. Lenses L_2 and L_3 project an image of the spots onto the back focal plane of L_3 with a linear magnification of f_3/f_2 . The total distance d between the front and back focal planes of the systems is

$$d = 2(f_1 + f_2 + f_3)$$

For a given value of EFL, length d is minimized by making $f_1 = f_3$, with f_2 as small as possible.

(continued overleaf)

Reasonable values for the memory system parameters are $f_1 = f_3 = 410$ mm, with $f_2 = 12.5$ mm. This gives an EFL = 13.4 m, with $d = 1.67$ m. The optical apertures are sufficiently small that diffraction-limited operation can be obtained using simple lenses for L_1 and L_2 and a doublet for L_3 corrected for spherical aberration.

Note:

Requests for further information may be directed to:

Technology Utilization Officer
Marshall Space Flight Center
Code AT01
Marshall Space Flight Center, Alabama 35812
Reference: B74-10293

Patent status:

Inquiries concerning rights for the commercial use of this invention should be addressed to:

Patent Counsel
Marshall Space Flight Center
Code CC01
Marshall Space Flight Center, Alabama 35812

Source: W. C. Stewart of
RCA Corp.
under contract to
Marshall Space Flight Center
(MFS-23107).