

NASA TECH BRIEF

Marshall Space Flight Center



NASA Tech Briefs announce new technology derived from the U.S. space program. They are issued to encourage commercial application. Tech Briefs are available on a subscription basis from the National Technical Information Service, Springfield, Virginia 22151. Requests for individual copies or questions relating to the Tech Brief program may be directed to the Technology Utilization Office, NASA, Code KT, Washington, D.C. 20546.

Mechanical Solar Motor: A Concept

A solar-energy powered motor is proposed to convert radiation from the sun directly into mechanical energy. The motor utilizes the thermal expansion of a liquid, heated by the sun, as the driving force. Unlike most thermally powered systems (e.g., steam turbines), it does not require that the liquid be converted into a vapor.

The construction of the proposed motor is shown in Figure 1. The motor consists of a fixed inner ring

around which a hollow tube is wrapped, like a steel tape measure. The hollow tube is rigidly attached to the inner ring at a single point. It is also attached at a single point to a movable outer ring.

Hot and cold water are alternately passed through the tube. This causes the expansion and contraction of the tube, which moves the outer ring back and forth. To reduce friction, the tube is coated with

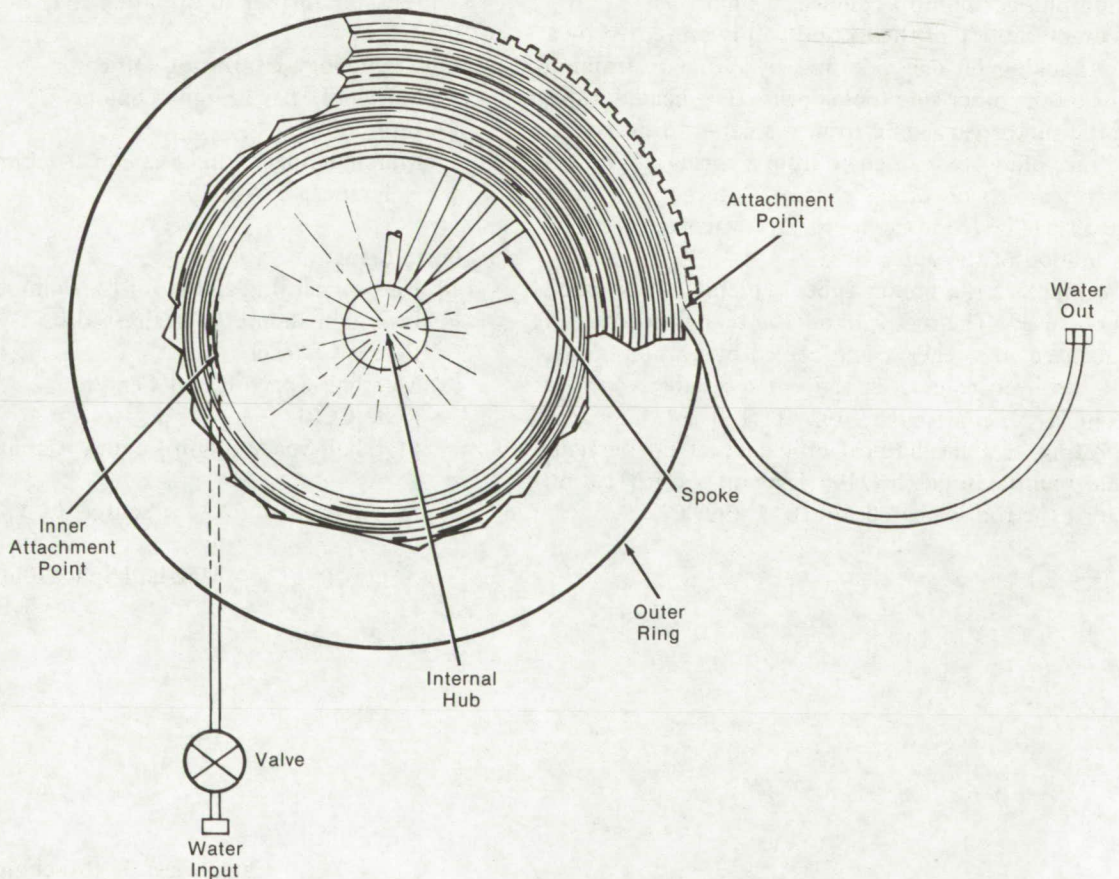

Figure 1. Construction of Solar Motor

(continued overleaf)

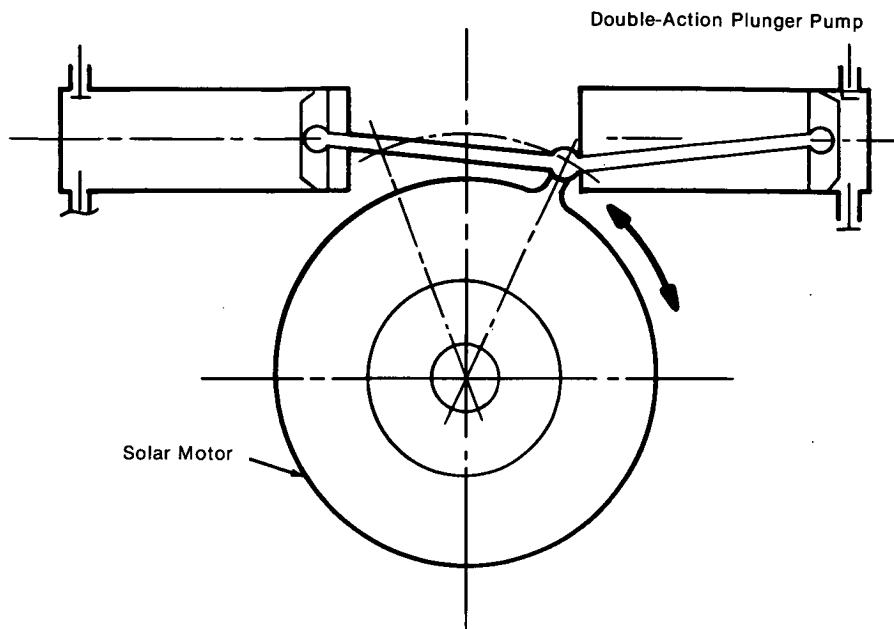

Figure 2. Motor Used to Drive Pump

Teflon. This motion could be used to power a double-action plunger pump as shown in Figure 2.

Lateral motion of the wound coil is prevented by a steel backing on one side and by radial restraining arms on the other side (not shown). The heated water for the motor can come from a solar heating panel, and the cold water can come from a spring, a gravity-fed reservoir, or other source. Alternating water sources can be fed to the motor by a valve operated by the motion of the outer ring.

In place of the hollow tube, a metal rod or band may be used. The rod or band can be heated directly by focused solar energy and cooled by a water spray.

It has been calculated that such a motor, with a 0.5-in. (12.7-mm) tube, 492 ft (150 m) long and operating at a mechanical efficiency of 60 percent, could pump 316 gal/h (1196 l/h) up a 6-ft (1.8-m) head if the rod is heated to 210° F (99° C).

Note:

Requests for further information may be directed to:

Technology Utilization Officer
 Marshall Space Flight Center
 Code AT01
 Marshall Space Flight Center, Alabama 35812
 Reference: B74-10292

Patent status:

Inquiries concerning rights for the commercial use of this invention should be addressed to:

Patent Counsel
 Marshall Space Flight Center
 Code CC01
 Marshall Space Flight Center, Alabama 35812

Source: L. A. Hein and
 W. N. Myers
 Marshall Space Flight Center
 (MFS-23062)