

NASA TECH BRIEF

NASA Pasadena Office



NASA Tech Briefs announce new technology derived from the U.S. space program. They are issued to encourage commercial application. Tech Briefs are available on a subscription basis from the National Technical Information Service, Springfield, Virginia 22151. Requests for individual copies or questions relating to the Tech Brief program may be directed to the Technology Utilization Office, NASA, Code KT, Washington, D.C. 20546.

Straight-Line IC Removal Tool

The problem:

Multipin dual in-line packaged (DIP) integrated circuits (IC's) which are installed in sockets must occasionally be removed for test or replacement. To remove them, a substantial force must be applied to dislodge the pins from the socket receptacles. To avoid bending or breaking any of the pins, the force must be applied in a line which is perpendicular to the socket plane. Makeshift tools which apply force at one end of an IC often cause damage to the IC or the socket as removal is effected.

The solution:

A removal tool which operates by applying force perpendicularly to the socket plane has been devised. The tool can be operated in cramped or confined quarters and can effect IC removal without damage.

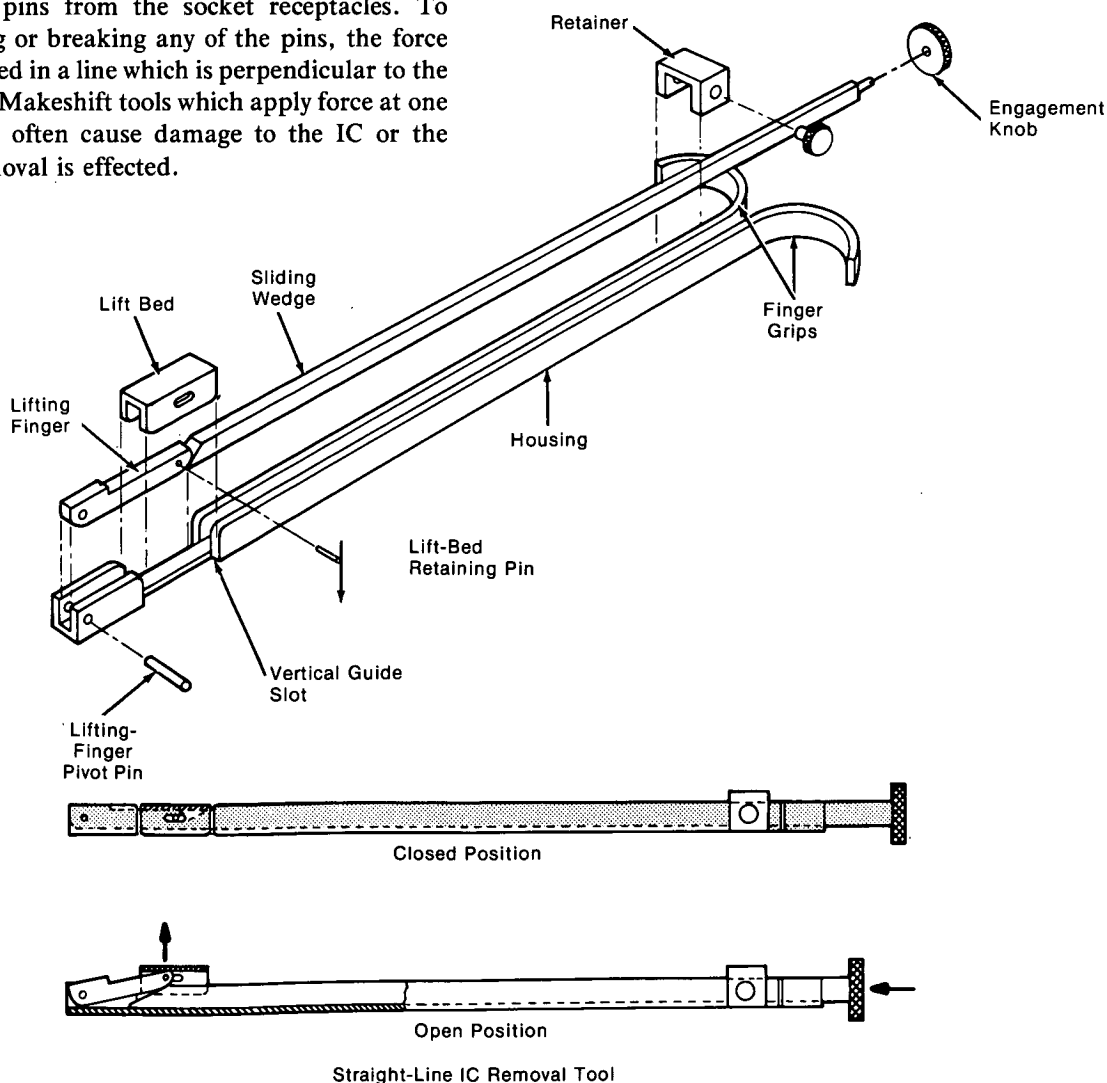

(continued overleaf)

How it's done:

The removal tool (see figure) has a small lift bed which is placed under the IC body and which can be raised straight up by means of a wedge-and-cam mechanism. While designed for the purpose of removing IC's, the tool can also be used to remove other devices where the application of a force perpendicular to the mounting surface is required. It may also be useful to hold a nut or a bolt in a confined space while tightening, when it is not possible to use a conventional tool. The lift bed, which is interchangeable, may have a retaining slot on its upper surface to mate with the fastener or other member which is to be held in position.

Note:

Requests for further information may be directed to:

Technology Utilization Officer
NASA Pasadena Office
4800 Oak Grove Drive
Pasadena, California 91103
Reference: TSP74-10281

Patent status:

This invention has been patented by NASA (U.S. Patent No. 3,832,764). Inquiries concerning non-exclusive or exclusive license for its commercial development should be addressed to:

Patent Counsel
NASA Pasadena Office
4800 Oak Grove Drive
Pasadena, California 91103

Source: Ronald A. Marzek and
William S. Read of
Caltech/JPL
under contract to
NASA Pasadena Office
(NPO-13157)