

NASA TECH BRIEF

Goddard Space Flight Center



NASA Tech Briefs announce new technology derived from the U.S. space program. They are issued to encourage commercial application. Tech Briefs are available on a subscription basis from the National Technical Information Service, Springfield, Virginia 22151. Requests for individual copies or questions relating to the Tech Brief program may be directed to the Technology Utilization Office, NASA, Code KT, Washington, D.C. 20546.

Implementation of a Self-Controlling Heater: A Concept

The problem:

Precision temperature control, a common requirement in modern instrumentation, is accomplished either with "on-off" thermostats or with proportional control devices. Of the two methods, proportional control is usually preferred because it prevents cyclical temperature excursions in the controlled body and possible electrical interferences. Either method, however, normally requires installation of a separate heater and sensor on the part to be controlled. With very small parts or thin filaments, these often cannot be mounted without perturbing the temperature distribution, increasing heat losses, or producing instability due to excessive lag between heater and sensor.

The solution:

A self-controlling heater is proposed which combines the heating and sensing functions.

How it's done:

The proposed heater uses its own temperature coefficient for the sensing function. Heating power is supplied from a current source, the heater voltage containing the temperature information. In the closed loop configuration, a simple analog computation separates the heater voltage drop due to its temperature from the component due to the instantaneous drive level. The resulting measure of actual temperature is used as an input to conventional error control circuitry. A continuous, true proportional control system results.

In the simplified schematic of the self-controlling heater shown in the figure, amplifiers A_1 and A_2 perform the current-drive and offset/gain functions; amplifier A_3 is used for error comparison. Reference voltage V_R sets the temperature control point. The analog divider removes the component of heater voltage due to its heating current by dividing by error signal

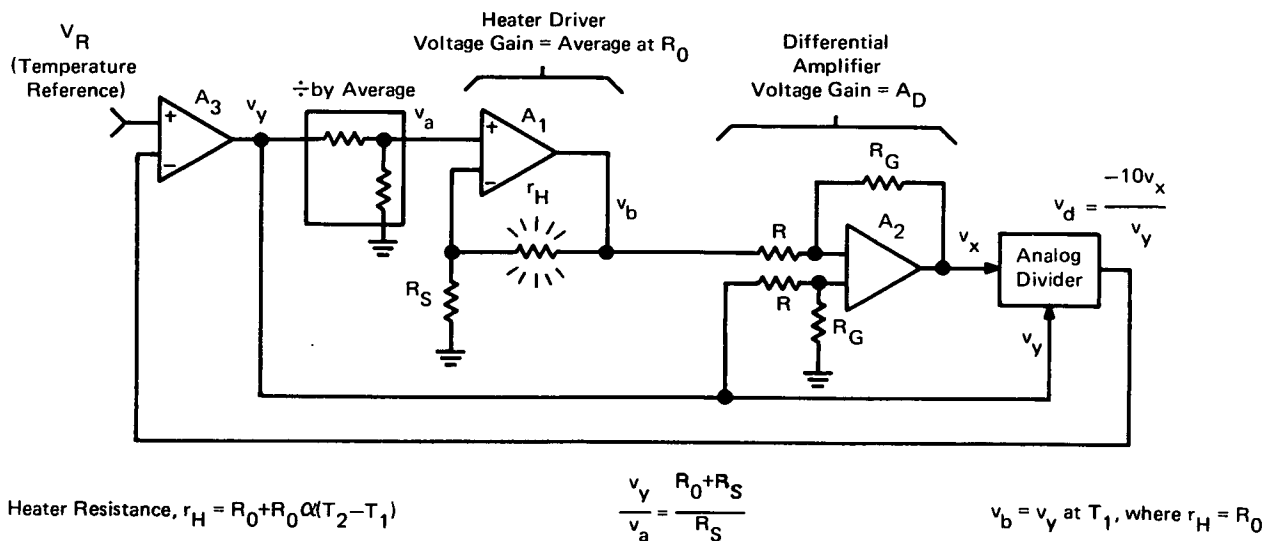

Simplified Schematic of the Self-Controlling Heater

(continued overleaf)

v_y ; the resulting voltage v_d then represents actual heater temperature. The design equation is

$$V_R = \frac{10A_D \alpha R_0 (T_2 - T_1)}{R_0 + R_S}$$

where V_R = temperature-set reference voltage

T_1 = reference temperature,

T_2 = desired temperature,

R_0 = heater resistance at temperature T_1 ,

R_S = current-sampling resistance,

A_D = gain of differential amplifier A_2 , and

α = temperature coefficient of resistivity of the heater.

An experimental circuit constructed using a copper heater ($\alpha = 0.00381$) has controlled temperatures at set points between 30° and 70° C. The accuracy is within $\pm 0.5^\circ$ C over an ambient range of 50° C.

Notes:

1. The proposed design may be used for controlling the temperature of thin wire filaments by employing the filaments themselves as self-controlling heaters. One application might be to control low-temperature incandescent calibration lamps for radiation standards. It may also be applied in many other areas that use conventional temperature controls.
2. Temperature may be easily programed by varying the reference voltage. The closed-loop control provides fast stabilization as well as immunity to outside thermal disturbances.

3. Dynamic stability is very high since there is no thermal lag as would exist with a separate heater and sensor.

4. The following documentation may be obtained from:

National Technical Information Service

Springfield, Virginia 22151

Single document price \$3.00

(or microfiche \$2.25)

Reference: NASA TND-7248 (N73-24479), Implementation of a Self-Controlling Heater

5. Technical questions may be directed to:

Technology Utilization Officer

Goddard Space Flight Center

Code 207.1

Greenbelt, Maryland 20771

Reference: B74-10241

Patent status:

This invention is owned by NASA and a patent application has been filed. Inquiries concerning non-exclusive or exclusive license for its commercial development should be addressed to:

Patent Counsel

Goddard Space Flight Center

Code 204

Greenbelt, Maryland 20771

Source: Maxwell G. Strange
Goddard Space Flight Center
(GSC-11752)