

# NASA TECH BRIEF

## NASA Pasadena Office



NASA Tech Briefs announce new technology derived from the U.S. space program. They are issued to encourage commercial application. Tech Briefs are available on a subscription basis from the National Technical Information Service, Springfield, Virginia 22151. Requests for individual copies or questions relating to the Tech Brief program may be directed to the Technology Utilization Office, NASA, Code KT, Washington, D.C. 20546.

### Interplex Modulation and a Supressed-Carrier Tracking Loop for Coherent Communications Systems

#### The problem:

In previous two-channel telemetry systems, there has been a power loss due to the intermodulation between the high-rate and the low-rate channels. Typically, this intermodulation loss has been much greater than the power allocated to the low-rate channel. Also, to minimize that loss, the amount of power allocated to the phase reference (carrier) has been far in excess of the amount needed for tracking.

#### The solution:

A simple addition to the hardware and a new mode of operation of the transmitter and the receiver in a coherent, PCM/PSK/PM configuration greatly improve channel efficiency. The new system is called Interplex from the fact that the high-rate and the low-rate channels are multiplied together before modulating the carrier. This procedure reduces the amount of power lost to intermodulation products. The Interplex system saves additional power by maintaining the phase-reference power at the design level. The power saved can be transferred to one or both of the data channels to increase the data rate, the reliability, or both. Alternatively, this saved power can be used to decrease the total power requirements for a specified level of performance. The new system adds a multiplier to the transmitter of a standard two-channel telemetry system. At the receiver, low-rate data is taken from the quadrature channel of the phase-lock loop detector. The modulation angles are changed at the transmitter for optimum distribution of power among the carrier and the data channels.

Near 100 percent efficiency can be achieved with Interplex operating in the suppressed-carrier mode, in which all available power is allocated to the data-bearing sidebands. In this mode, a new detector system is used to maintain frequency and phase sync at the receiver. The suppressed-carrier detector loop provides

the phase-tracking control signal by first separating the correlated signal and its quadrature into their subcarriers, using band-pass filters. The corresponding subcarrier signals are then multiplied and combined in a linear manner such that the variance of the phase error is minimized.

#### How it's done:

In the transmitter (see figure), the high-rate data,  $d_1(t)$ , is combined in the mixer, X, with the low-rate data,  $d_2(t)$ , before either data phase modulates its respective channel subcarrier. The rest of the transmitter is conventional. The output of the transmitter may be expressed as

$$X''(t) = \sqrt{2P} \sin [\omega_c t + \theta_1 a_1(t) + \theta_2 d_1(t) a_2(t)]$$

where  $a_1(t) = d_1(t) \text{sq}(\omega_1 t)$ ,  
 $a_2(t) = d_2(t) \text{sq}(\omega_2 t)$ , and  
 $\theta_1$  and  $\theta_2$  = modulation angles of the first and second data channels.

This compares with the output of an unmodified transmitter

$$X(t) = \sqrt{2P} \sin [\omega_c t + \theta_1 a_1(t) + \theta_2 a_2(t)]$$

and reflects the multiplication of the high-rate and low-rate data channels.

As shown in the figure, the only change in the conventional receiver is an added mixer, Y. This mixer combines the quadrature channel output with  $\text{sq}(\omega_1 t)$  before it is applied to the final mixer. The output of mixer Y is:

$$\sqrt{P_c} \text{sq}(\omega_1 t) + \sqrt{P_2} d_2(t) \text{sq}(\omega_2 t),$$

and the output of the final mixer is

$$\sqrt{P_c} \text{sq}(\omega_1 t) \text{sq}(\omega_2 t) + \sqrt{P_2} d_2(t).$$

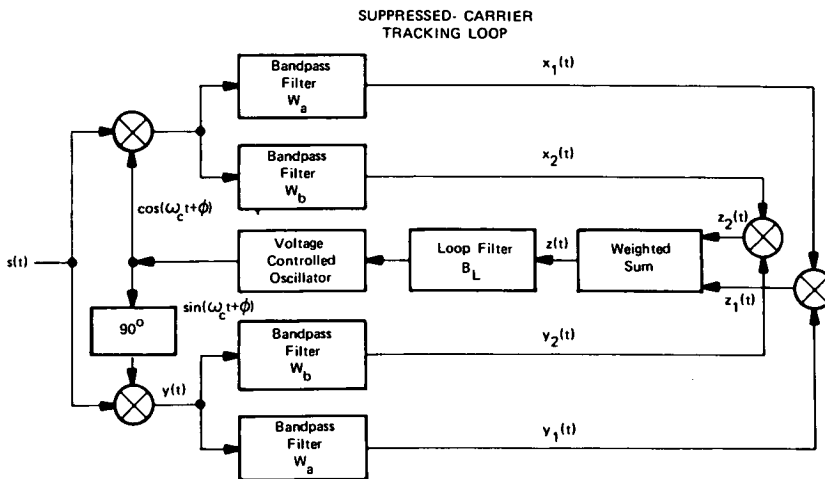
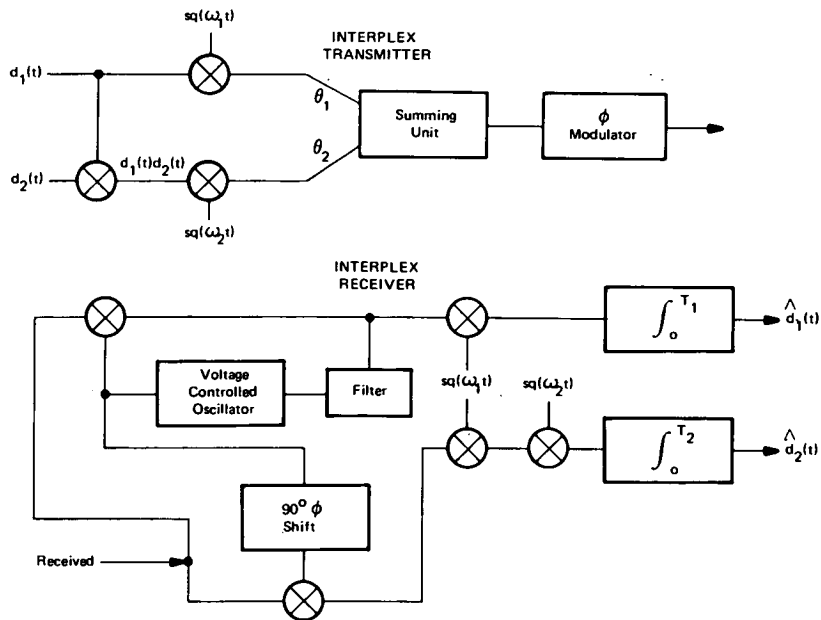

Improved Coherent Communication System

Such a signal is then a function of the subcarrier of the high-rate channel. This signal, when received by either receiver of the two-channel system, can be detected at the quadrature channel output. The Interplex technique is applicable for systems of two or more channels.

**Note:**

Requests for further information may be directed to:  
 Technology Utilization Officer  
 NASA Pasadena Office  
 4800 Oak Grove Drive  
 Pasadena, California 91103  
 Reference: TSP74-10209

**Patent status:**

This invention has been patented by NASA (U.S. Patent No. 3,710,257). Inquiries concerning nonexclusive or exclusive license for its commercial development should be addressed to:

Patent Counsel  
 NASA Pasadena Office  
 4800 Oak Grove Drive  
 Pasadena, California 91103

Source: Stanley Butman and Uzi Timor of Caltech/JPL under contract to NASA Pasadena Office (NPO-11572)