

NASA TECH BRIEF

Langley Research Center



NASA Tech Briefs announce new technology derived from the U.S. space program. They are issued to encourage commercial application. Tech Briefs are available on a subscription basis from the National Technical Information Service, Springfield, Virginia 22151. Requests for individual copies or questions relating to the Tech Brief program may be directed to the Technology Utilization Office, NASA, Code KT, Washington, D.C. 20546.

Apparatus for Monitoring Linear Explosive Performance

Monitoring apparatus and test techniques have been developed at LRC to measure the performance of linear explosive, mild detonating fuse, and flexible linear shaped charge. These techniques provide a performance monitoring standard for acceptance, lot qualification, and comparison testing of these devices. In doing so, they have exhibited a high degree of simplicity, accuracy, and reproducibility, as well as providing engineering guidelines for system design in which linear explosives are applied.

The test apparatus, shown in the illustration, simultaneously measures the explosive pressure stimulus energy, explosive cutting, or rupturing, ability, and detonation propagation rate.

The specimen holder is a steel bar with a groove machined on each side to conform to the linear explosive test specimen and is replaced after five firings on each side. The witness plate is aluminum and can be used only once. The steel hold-down plate, used

for detonating fuse firings, provides a bearing surface on each side of the explosive when bolted rigidly to the frame and produces a rigid backup and confinement for the witness plate. The hold-down plate is not needed for the linear shaped charge firings, due to the directionality of the shaped charge output. The screw and clamp keep the energy sensor in its proper position and the replaceable interface plate provides protection for the energy sensor mechanism. Zinc chromate putty (a Fuller paint product) is used between the interface plate and fuse or explosive to act as a temporary seal and to make the interface more reproducible for all tests. Timing wires with associated capacitive circuits are placed across the explosive specimen at each end of the witness plate to accomplish the timing of the detonation propagation velocity. Upon arrival of the detonation at a timing wire, an electrical short circuit is produced which discharges the respective capacitors. The resultant electrical pulses are monitored by an electronic timer.

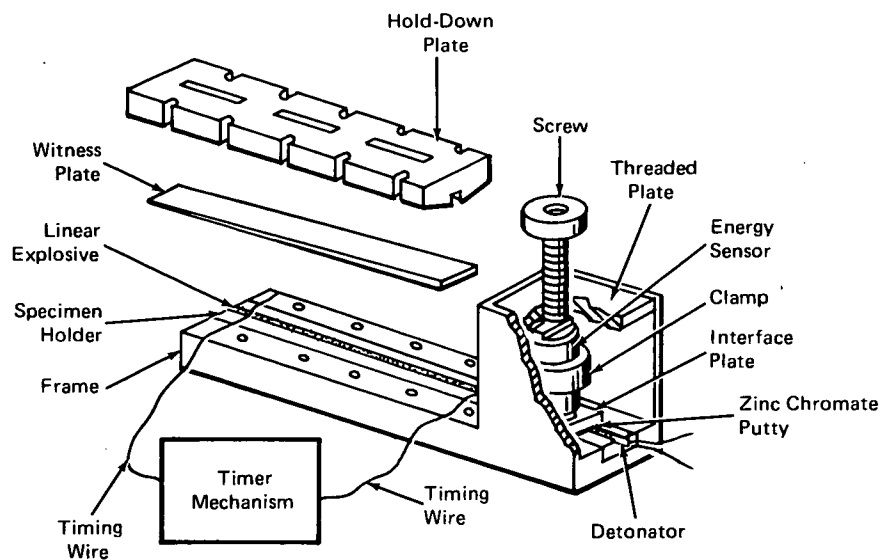

Apparatus for Monitoring Linear Explosive Performance

(continued overleaf)

The initial two-inch (five-cm) length of the explosive column, when ignited by a detonator, assures stable detonation before any measurements are made. The next two-inch length provides an impulse to the energy sensor. The first timing wire, short-circuited to ground by the explosion, starts the timer. The explosive specimen detonation then cuts the witness plate to its maximum capability and then short circuits the second timing wire, which stops the timer.

The energy output is computed by multiplying the displacement of the honeycomb contained in the piston/cylinder energy sensor by its known crush strength. The cutting ability of the test specimen is established by measuring the thickness of the plate at the point where complete rupturing occurs for fuse firings or where cracking ends for shaped charge firings. The time durations measured by the timer provides velocity of propagation data over the 30.9 cm (12.17 inch) length of the test specimen.

Note:

Requests for further information may be directed to:
Technology Utilization Officer
Langley Research Center
Mail Stop 139-A
Hampton, Virginia 23665
Reference: B74-10201

Patent status:

This invention has been patented by NASA (U.S. Patent No. 3,670,559). Inquiries concerning nonexclusive or exclusive license for its commercial development should be addressed to:

Patent Counsel
Langley Research Center
Mail Stop 456
Hampton, Virginia 23665

Source: Laurence J. Bement
Langley Research Center
(LAR-10800)