

# NASA TECH BRIEF

## NASA Headquarters



NASA Tech Briefs announce new technology derived from the U.S. space program. They are issued to encourage commercial application. Tech Briefs are available on a subscription basis from the National Technical Information Service, Springfield, Virginia 22151. Requests for individual copies or questions relating to the Tech Brief program may be directed to the Technology Utilization Office, NASA, Code KT, Washington, D.C. 20546.

### Digital Multichannel Photometer

A new digital multichannel photometer system has been developed for use in astronomy and other research areas concerned with the detection of faint-light images. The photometer system is comparable in performance to a good photomultiplier tube array except that digital electronics are used instead of analog. The digital

circuits allow substantial reductions in cost, weight, and size of the system.

The photometer system incorporates a conventional, single-stage, magnetically-focused diode tube as shown in Figure 1. Light coming from a faint image is converted into electron current at the cesium anti-

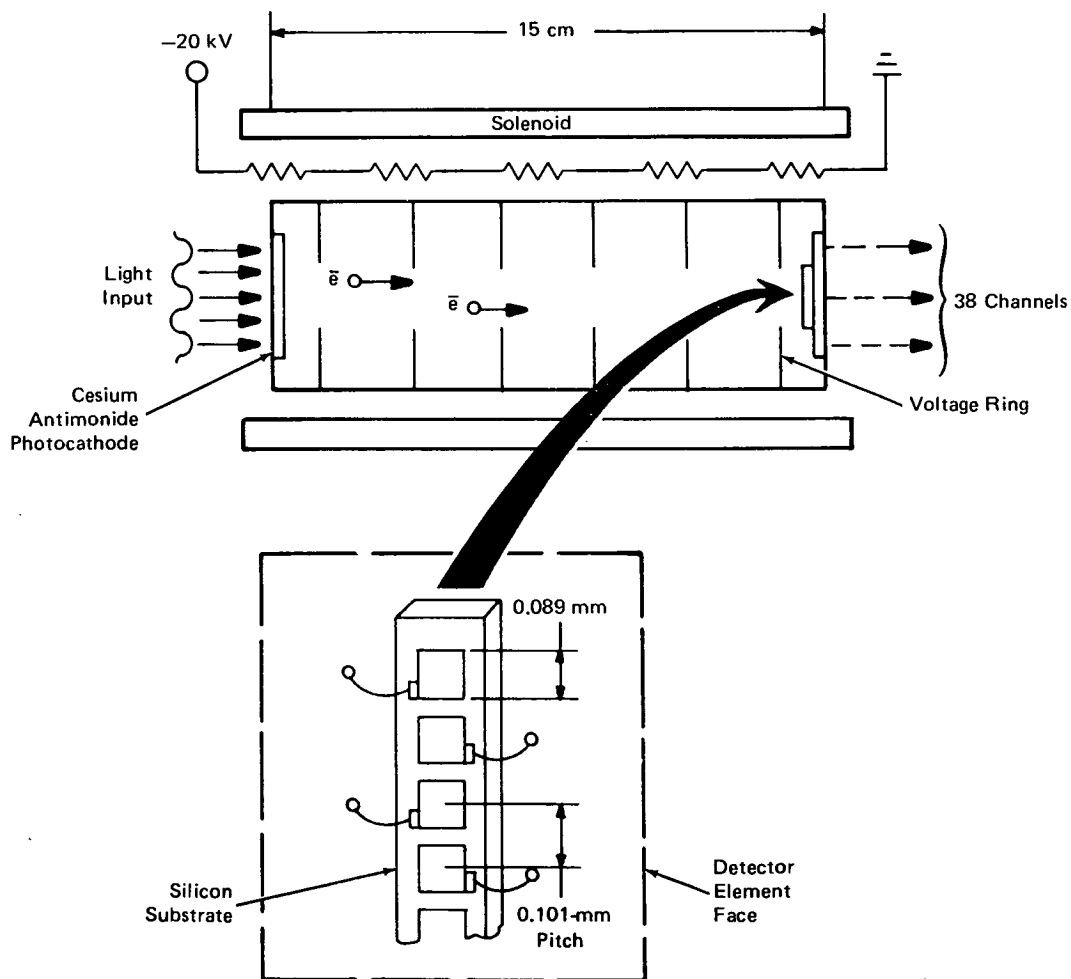

Figure 1. Diode Tube

(continued overleaf)

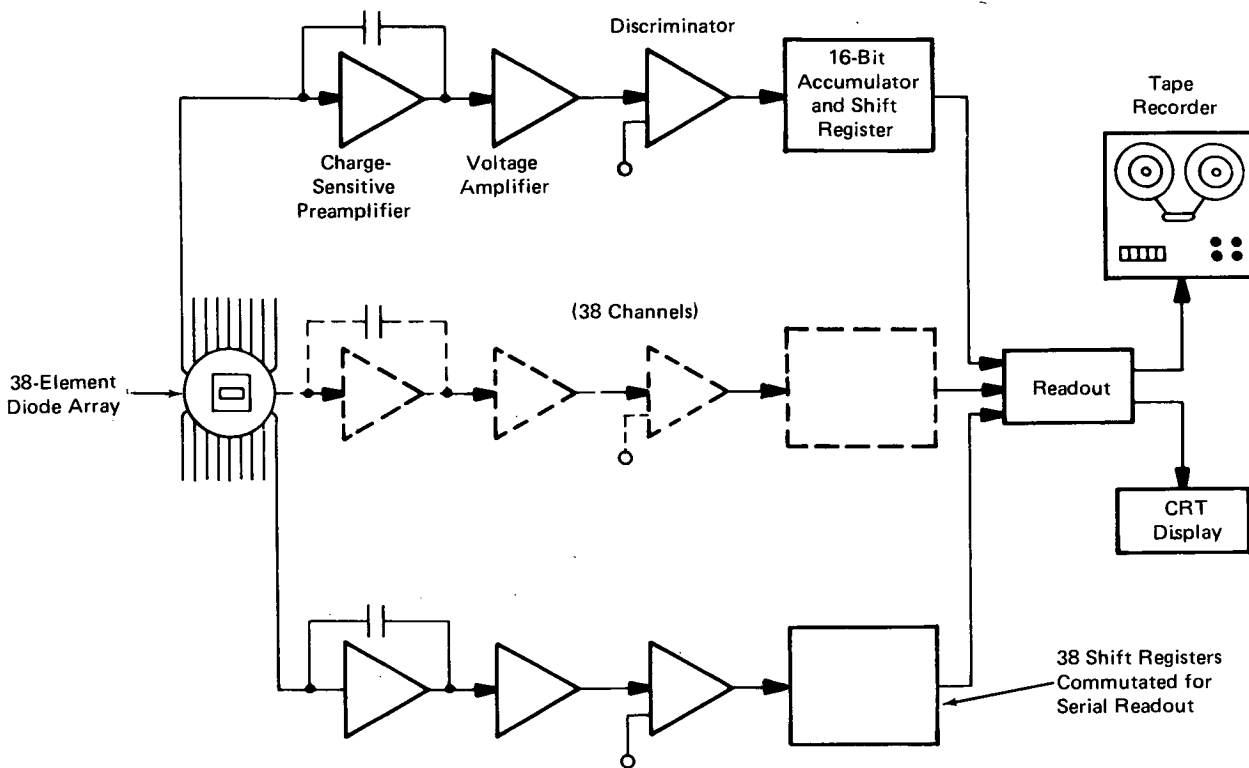

Figure 2. Photometer System

monide photocathode. These electrons are accelerated through a 20-kV potential, reaching energies of 20 keV. They are focused onto a linear diode array comprising 38 diffused p-n diodes on a silicon wafer.

Each diode is 0.089- by 0.089-mm square connected to a separate circuit channel (see Figure 2). Every channel includes a charge-sensitive preamplifier, an amplifier, a discriminator, and a digital accumulator for the detection of photoelectron arrivals. As each electron enters the diode depletion region, an electron-hole pair is produced for every 3.5-eV energy loss. Thus, an electron losing 16 keV of energy in the depletion region produces a charge pulse of approximately  $7.3 \times 10^{-16}$  coulombs. This charge is easily detected by the charge-sensitive preamplifier.

The preamplifiers are constructed using low-noise field-effect transistors. However, there is a low-energy noise component in the preamplifier output which is eliminated in the discriminator. The output is fed to a 16-bit accumulator and shift register which accumulates the image information and feeds it serially to a tape recorder or a cathode-ray tube (CRT) display, while the next accumulation is taking place.

Results show that the tube dark current at 20 kV and a temperature of 35° C is approximately 200 electrons/s/cm<sup>2</sup>, which suggests that most of the dark current is due to thermionic emission of the photo-

cathode. Since each detector is approximately 10<sup>-4</sup> cm<sup>2</sup> in area, the dark-current rate per diode is approximately 0.02 count/s. The present tube design can be expanded to include 1000 diode elements. In addition, different diode arrays can be generated for different applications.

#### Note:

Requests for further information may be directed to:  
 Technology Utilization Officer  
 NASA Headquarters  
 Code KT  
 Washington, D. C. 20546  
 Reference: TSP74-10200

#### Patent status:

Title to this invention has been waived under the provisions of the National Aeronautics and Space Act [42 U.S.C. 2457(f)], to the University of California, Berkeley, California 94720.

Source: Edward A. Beaver and  
 Carl E. McIlwain of  
 University of California  
 under contract to  
 NASA Headquarters  
 (HQN-10791)