

NASA TECH BRIEF

NASA Pasadena Office



NASA Tech Briefs announce new technology derived from the U.S. space program. They are issued to encourage commercial application. Tech Briefs are available on a subscription basis from the National Technical Information Service, Springfield, Virginia 22151. Requests for individual copies or questions relating to the Tech Brief program may be directed to the Technology Utilization Office, NASA, Code KT, Washington, D.C. 20546.

Minicomputer-Controlled Frequency Generator

A minicomputer has been used to build an extremely-accurate and low phase-noise frequency generator that varies an oscillator frequency as a predetermined function of time. The system has several potential commercial applications; and it can be quickly added to existing product lines, since it is constructed almost entirely from readily available equipment. It could be used: (a) to automatically vary transmission frequencies in accordance with seasonal and diurnal changes in ionospheric conditions, (b) as an automatic tuner for heterodyne receivers, or (c) as a control element for phase-locked telemetry receivers.

The programmed oscillator is diagrammed in the illustration: a modified commercial frequency synthesizer and a minicomputer are connected in a central-loop configuration. At the beginning of a day's operation, time and control constants are input to the computer, which is programmed to calculate the desired frequency variations with time. The frequency synthesizer has a specially-selected, low phase-noise search oscillator with a 200-Hz range, symmetrical about the center frequency. The synthesizer is modified to provide an expanded (multiplied and frequency-translated) function of the search oscillator frequency on a separate output. (Thus, in one system, the 200-Hz oscillator range corresponds to a 12.8-kHz range at an S-band frequency of 2388 MHz.)

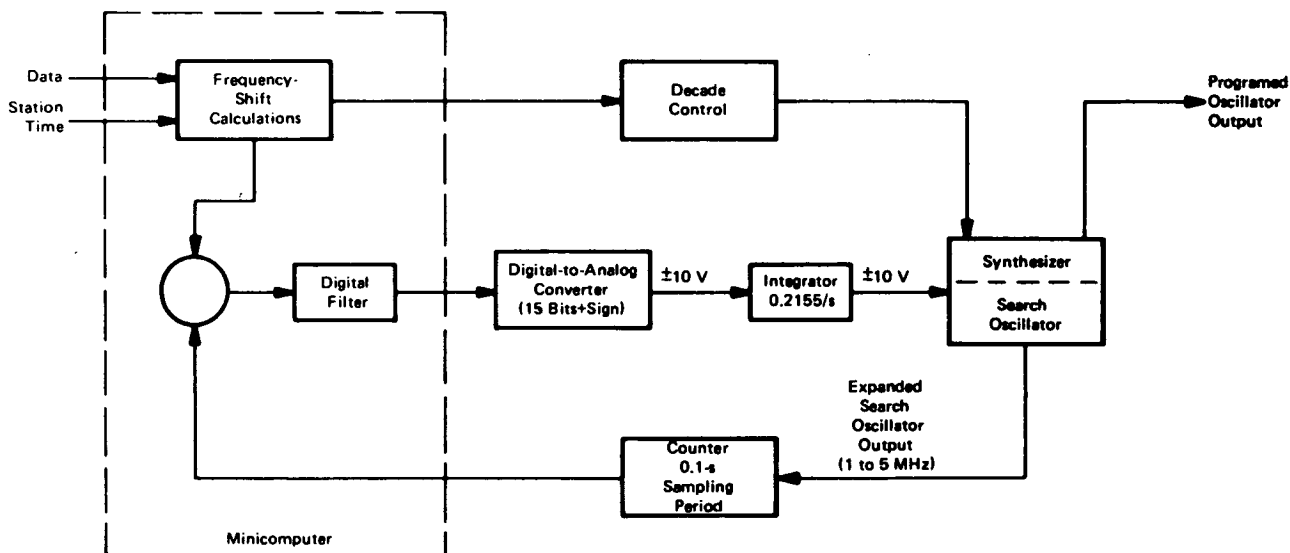

Programed Oscillator Block Diagram

(continued overleaf)

The minicomputer sets the frequency range on the search oscillator through a decade with control logic, and frequencies are varied within the selected 200-Hz range by controlling the search oscillator in a sampled-data feedback loop. A 32-bit counter continuously samples the expanded output of the oscillator, recycling to zero when the full count is reached. Every one-tenth second, the sample is dumped into a buffer register and fed to the computer. The computer forms error numbers by comparison with the calculated desired phase. The error numbers are digitally filtered and passed to a digital-to-analog converter and then to an integrator. The voltage-controlled search oscillator (± 10 -volt control range corresponding to the 200-Hz oscillator range) is then adjusted to the desired frequency.

This system requires only a single rack of equipment and may be operated in a phase-tracking mode as well as frequency tracking. One system now in operation has the following characteristics:

| | <u>Oscillator</u> | <u>S-Band Output</u> |
|------------------------------------|-------------------|--------------------------|
| Output range | 200 Hz | 12.8 kHz |
| Phase control (least increment) | 0.018° | 1.15° |
| Frequency change rate (maximum) | 21.55 Hz/s | 1379 Hz/s |
| Jitter | 0.02° | 1.28° |
| Drift | 0.03°/min | 1.92°/min |

Note:

Requests for further information may be directed to:
 Technology Utilization Officer
 NASA Pasadena Office
 4800 Oak Grove Drive
 Pasadena, California 91103
 Reference: TSP74-10163

Patent status:

This invention has been patented by NASA (U.S. Patent No. 3,764,933). Inquiries concerning nonexclusive or exclusive license for its commercial development should be addressed to:

Patent Counsel
 NASA Pasadena Office
 4800 Oak Grove Drive
 Pasadena, California 91103

Source: Robin A. Winkelstein of
 Caltech/JPL
 under contract to
 NASA Pasadena Office
 (NPO-11962)