

# NASA TECH BRIEF

## Marshall Space Flight Center



NASA Tech Briefs announce new technology derived from the U.S. space program. They are issued to encourage commercial application. Tech Briefs are available on a subscription basis from the National Technical Information Service, Springfield, Virginia 22151. Requests for individual copies or questions relating to the Tech Brief program may be directed to the Technology Utilization Office, NASA, Code KT, Washington, D. C. 20546.

### Self-Leveling Load Table

#### The problem:

Docking maneuvers between space vehicles are simulated on specially designed tables which must remain horizontal at all times. The mechanical tables that are used for this purpose are very heavy and bulky. They rest on many legs which need frequent adjustments because the changing temperatures of the surrounding environment offset leveling. In addition, the tables are sensitive to underground shocks and therefore require expensive substructural supports.

#### The solution:

A new table has been developed which levels itself automatically.

#### How it's done:

The table floats in a tank of water and has air compartments underneath. Table height and level are controlled by the automatic adjustment of air pressure within these compartments.

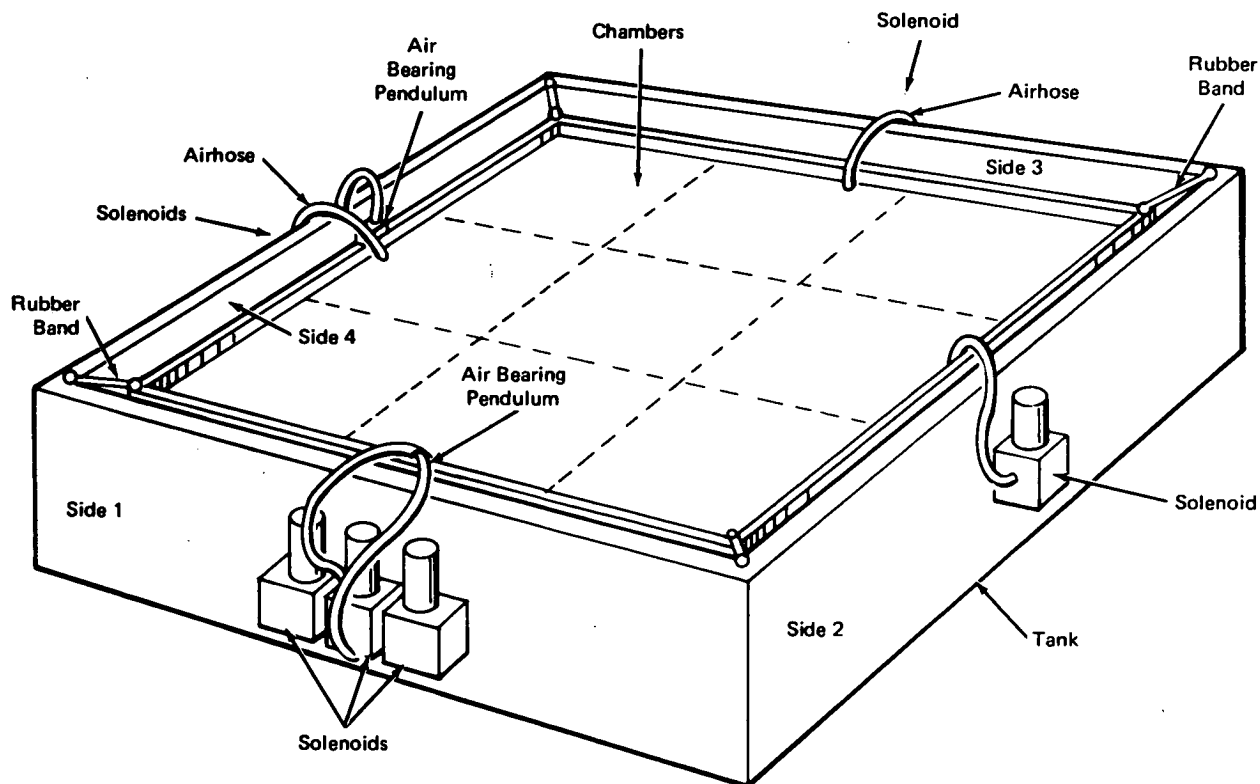

Self-Leveling Table Assembly

(continued overleaf)

As shown in the illustration, the assembly includes a tank which is filled with water to support the table. The bottom part of the table has nine square chambers. The middle chamber on each side admits an air hose for air pressure control. The table is centered in the tank by four rubberbands attached to its corners.

The air pressure in the chambers is controlled for two reasons: first, to maintain the table constantly level and, second, to keep the table from submerging too deeply or rising too high in the tank.

Table level is controlled with two pendulum air bearings which are mounted on the adjacent sides of the table (sides 1 and 4 in the illustration). The air bearing on side 1 is electrically connected to the solenoid valves on sides 2 and 4, while the air bearing on side 4 is connected to solenoid valves on sides 1 and 3. Therefore, when the table is offset from the horizontal, one or both of the bearings will activate the respective solenoid valves to allow air pressure into the proper chambers.

In addition to the horizontal level control, the assembly includes a depth switch (not shown) which is mounted on the bottom of the tank. The switch generates a signal when the table immerses too deeply or when it rises too high in the tank. This signal controls the solenoid valves on all four sides simultaneously, either to allow additional pressure to raise the table or to evacuate the pressure to lower the level.

**Note:**

Requests for further information may be directed to:  
Technology Utilization Officer  
Marshall Space Flight Center  
Code AT01  
Marshall Space Flight Center, Alabama 35812  
Reference: B74-10144

**Patent status:**

This invention is owned by NASA, and a patent application has been filed. Inquiries concerning non-exclusive or exclusive license for its commercial development should be addressed to:

Patent Counsel  
Marshall Space Flight Center  
Code CC01  
Marshall Space Flight Center, Alabama 35812

Source: J. L. Burch  
Marshall Space Flight Center  
(MFS-22039)