

NASA TECH BRIEF

Langley Research Center



NASA Tech Briefs announce new technology derived from the U.S. space program. They are issued to encourage commercial application. Tech Briefs are available on a subscription basis from the National Technical Information Service, Springfield, Virginia 22151. Requests for individual copies or questions relating to the Tech Brief program may be directed to the Technology Utilization Office, NASA, Code KT, Washington, D. C. 20546.

Heat-Transfer Thermal Switch

A thermal switch was devised to maintain the temperature of a planetary lander, within a definite range, by transferring heat. It was necessary that the device produce a relatively large stroke and force, use a minimum of electrical power, and be light in weight. This transfer switch meets these requirements and withstands sterilization temperatures on the order of 419 K (295° F) without damage. The device is vapor pressure actuated and consists of two major sub-assemblies (see illustration). The contactor is the heat-transfer subassembly and contains a heated platen, a soft contact seat, flexible-foil copper conductors, a base block, and linkage. The actuator subassembly is the temperature sensor and produces the force to open and close the contact seats.

The thermal switch is powered by a vapor pressure actuator in which Freon is used as the pressure agent. For a given temperature, the vapor pressure of Freon is constant and thus permits the actuator bellows to stroke without pressure loss due to volume increase. A linkage mechanism transmits actuator motion to a movable thermal contact (shown closed) which is connected by flexible conductors to the base. The base is fastened to the component to be heated. The movable thermal contact closes on a continuously heated platen whenever the actuator temperature drops below an established level. For slow decreases in temperature, the thermal switch responds by closing to near contact (convection heating), through light contact, to full pressure contact.

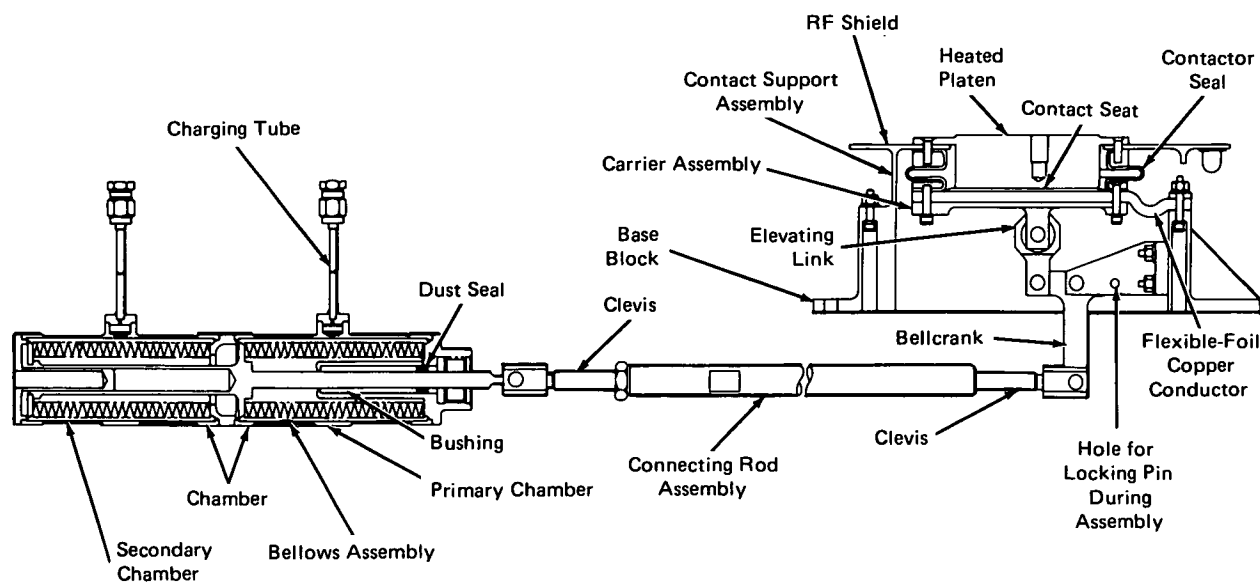

Heat-Transfer Thermal Switch

(continued overleaf)

The component, the temperature of which is to be controlled, is attached to the actuator subassembly by bolts through footpads that are integral with the actuator body. This provides good heat transfer and the highest practical response to temperature changes. The actuator body is a stainless steel pressure chamber which is divided into two sections by metallic bellows. The bellows serve as flexible barriers to retain the Freon and are sized to provide the spring force to close the thermal contacts. One end of each of the bellows is welded to a header on a shaft, which transmits the bellows motion to the thermal contact seat through a connecting rod, a bellcrank, and an elevating link.

Attached to the movable thermal contact seat are flexible copper-foil thermal conductors that convey heat to the base. These flexible conductors are made from 200 leaves of copper 0.003 cm (0.001 in.) thick which are assembled into a cross shape. They are diffusion bonded where they intersect at the middle and at the outer ends of the four arms. This provides each arm with a flexible unbonded center section. The ends of the arms are attached to the base block after being set in conductive silicone grease, to provide minimum contact resistance.

The intersection of the cross shape is part of the movable contact seat. It is made soft to provide good thermal contact even with contaminants such as dust. The soft seat is a composite made by casting a thin layer of tin 5.08 cm (2 in.) square on the copper foil, applying thermally conductive silicone grease, and covering it with gold-nickel foil. The seat will accept a piece of wire 0.1588 cm (0.0625 in.) long by 0.0254 cm (0.0100 in.) in diameter without reducing thermal conductance.

The thermal conductance data from the switch, which is designed to operate on the planet Mars, is as follows:

	<u>Measured Conductance</u> <u>[J/hr °C (Btu/hr °F)]</u>
1. Switch open	
a. Mars surface, 15 torr CO ₂ pressure	133 (0.07)
b. Vacuum, 2x10 ⁻⁶ torr	37.9 (0.02)
2. Switch closed	
a. Mars surface, 2 torr CO ₂ pressure	9485 (5.0)
b. Vacuum, 2x10 ⁻⁶ torr	8537 (4.5)

This thermal switch is designed to be fully closed at 278 K (40° F) and fully open at not more than 289 K (60° F), at atmospheric pressures from 6.67 to 20 torr.

Note:

Requests for further information may be directed to:
 Technology Utilization Officer
 Langley Research Center
 Mail Stop 139-A
 Hampton, Virginia 23665
 Reference: B74-10092

Patent status:

NASA has decided not to apply for a patent.

Source: M. V. Friedell and A. J. Anderson of
 Martin Marietta Corp.
 under contract to
 Langley Research Center
 (LAR-11232)