

# NASA TECH BRIEF

## Lewis Research Center



NASA Tech Briefs announce new technology derived from the U.S. space program. They are issued to encourage commercial application. Tech Briefs are available on a subscription basis from the National Technical Information Service, Springfield, Virginia 22151. Requests for individual copies or questions relating to the Tech Brief program may be directed to the Technology Utilization Office, NASA, Code KT, Washington, D.C. 20546.

### Electrometer System Measures Nanoamps at High Voltage

#### The Problem:

Measuring very low dc current at a voltage much higher than ground potential poses a serious problem due to stray leakage current. Elaborate guarding procedures or special high voltage supplies may be required. A secondary problem is often caused by arcing which could easily destroy the measuring instrument.

#### The Solution:

An electrometer system capable of floating (case connected directly to the high voltage source) at  $\pm 16$  KV and measuring current as low as  $10^{-10}$  amps. Floating the electrometer eliminates the major source of error since any leakage from the electrometer case, which is at high voltage, appears only as a load on the high voltage supply and not as part of the current being measured. Commands to and data from the floating electrometer are transferred across the high voltage interface by means of optical channels.

#### How It's Done:

As shown in the photograph, the electrometer system consists of two modules well insulated from each other by ceramic and epoxy-glass separators. The upper module

containing the electrometers is connected to the high voltage supply, while the lower one, which contains the command system, the digital readout system and some power conditioning components, is grounded.

The circuitry is shown schematically in the figure. Each of the three independent electrometer channels consists of a surge suppression network, bipolar analog electrometer, A/D converter, and a readout circuit. Channel one also incorporates switching to load a solar array and uses the A/D converter to measure its voltage.

Each electrometer input is protected by an RC network and low leakage gas surge suppressor. The electrometers are conventional logarithmic analog type that produce a 0-6 volt dc output. The output is digitized by a tracking A/D converter that feeds a readout register. On external command, this register shifts the data out serially through LED/photofet optical channels to the grounded module. There it is stored in data registers and is available in parallel form for readout.

All signals between the upper and lower modules are optically coupled by seven LED/photofet pairs. Four of these transmit commands and clock pulses to the upper module. The other three are the data channels for the three electrometers. The only other connection between the upper and lower modules is for operating power to the upper module. This is transferred as a 20 KHZ square wave to a high voltage isolation transformer in the upper module power supply.

#### Notes:

1. The complete electrometer system has been operated to  $\pm 16$  KV and subjected to direct shorts from electrometer inputs to ground with no damage or degradation. It can measure  $10^{-3}$  to  $10^{-10}$  amps over the full high voltage range with an accuracy of 5% or better (accuracy can be improved by utilizing all available bits from the A/D converter).

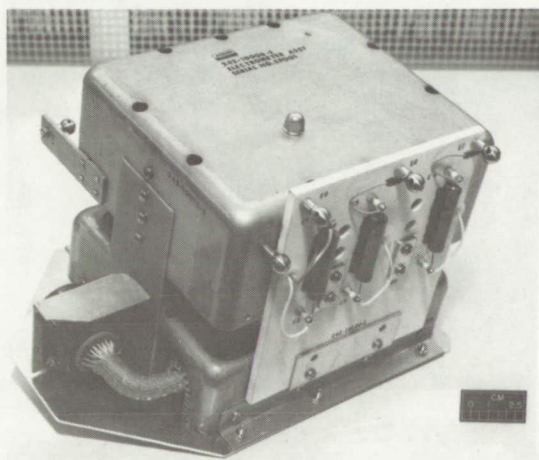

(continued overleaf)

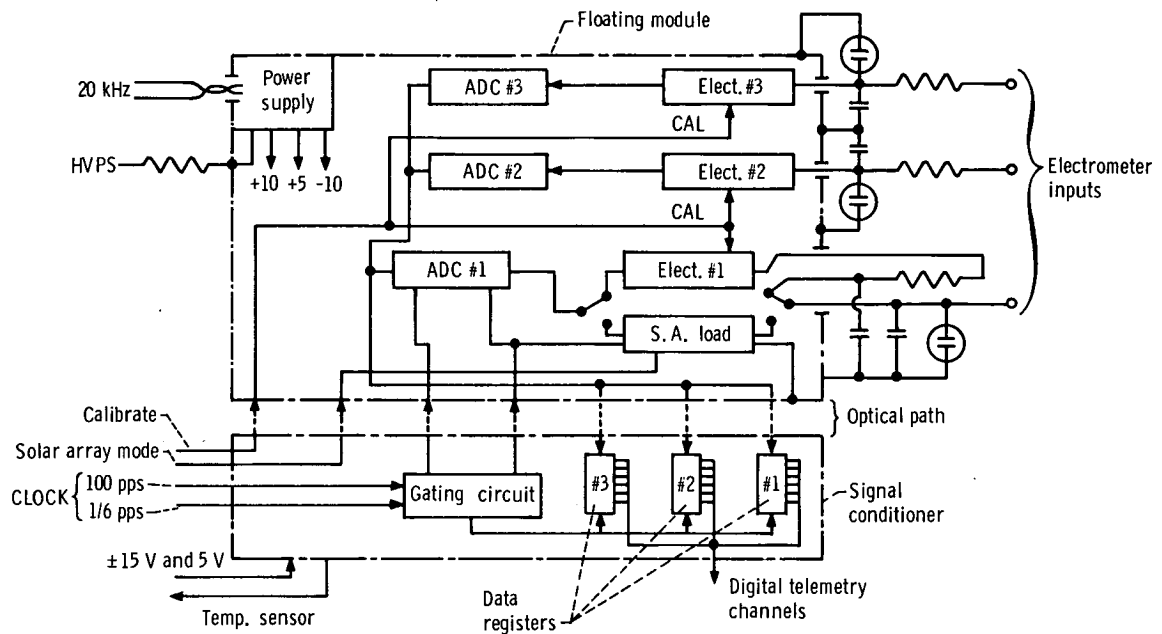

2. No additional documentation is available. Specific questions, however, may be directed to:

Technology Utilization Officer  
 Lewis Research Center  
 21000 Brookpark Road  
 Cleveland, Ohio 44135  
 Reference: B74-10064

**Patent Status:**

NASA has decided not to apply for a patent.

Source: J.C. Sturman, G.R. Sharp, R.R. Robson,  
 N.J. Stevens and D.H.E. Priebe  
 Lewis Research Center, and  
 R.G. Wetli  
 Boeing Aerospace Co.  
 under contract to  
 Lewis Research Center  
 (LEW-12267)