

May 1974

B74-10045

NASA TECH BRIEF

Ames Research Center



NASA Tech Briefs announce new technology derived from the U.S. space program. They are issued to encourage commercial application. Tech Briefs are available on a subscription basis from the National Technical Information Service, Springfield, Virginia 22151. Requests for individual copies or questions relating to the Tech Brief program may be directed to the Technology Utilization Office, NASA, Code KT, Washington, D. C. 20546.

Brake for Rollable Platform

The problem:

To provide a rollable platform with a brake which will lock in place on either level or irregular surfaces.

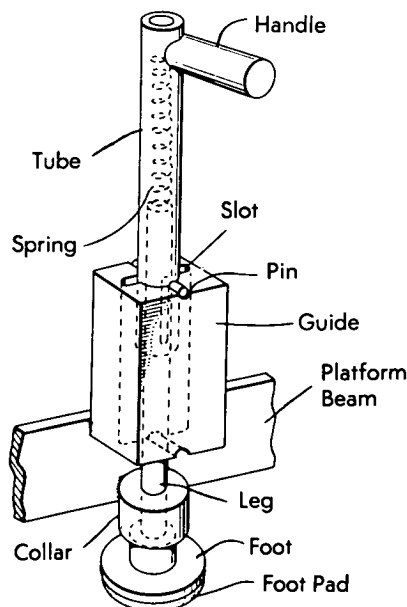

The solution:

A frame-mounted brake which is independent of the wheels and consists of a simple lever-actuated foot.

How it's done:

The diagram illustrates the brake in the raised position and mounted on the frame of a rollable platform between a pair of caster wheels. The collar and guide are welded or otherwise suitably fastened to the frame; the tube slides freely in the guide. The leg is mounted for sliding movement in the collar and terminates in the enlarged swivel-foot which may be

provided with a pad of rubber or other high-friction material.

When the brake is inoperative, the pin indicated in the diagram is held in an upper groove by gravity, so there is no tendency for the device to rattle or the tube to turn; the foot is held well above the surface on which the platform rests. To set the brake, it is only necessary to raise the handle slightly to disengage the pin from the upper groove and then turn it 90° in either direction so that the pin is lined up with the slot. Then, the handle is pushed down until the pin has cleared the bottom of the guide (causing the spring to be compressed somewhat and the foot to contact the ground) and rotated a quarter-turn in either direction so that the pin is now located in the lower groove (detent). The compressed spring holds the foot firmly in contact with ground, preventing the frame from moving. To release the brake, the procedure is reversed.

The brake is proportioned so that the pin is about halfway down the slot when the pad is level with the bottom of the wheels; this ensures that the brake will make a good contact with a surface even though the foot pad is at a higher or lower level than the wheels, a feature which is particularly important when the rollable platform is used on an irregular surface.

Note:

No additional documentation is available. Specific questions, however, may be directed to:

Technology Utilization Officer
Ames Research Center
Moffett Field, California 94035
Reference: B74-10045

Patent status:

This is the invention of a NASA employee, and

(continued overleaf)

U.S. Patent No. 3,715,015 has been issued to him. Inquiries concerning license for its commercial development may be addressed to the inventor: Mr. Arthur L. Morris, Ames Research Center, Moffett Field, California 94035.

Source: Arthur L. Morris
Ames Research Center
(ARC-10512)