



NATIONAL AERONAUTICS AND SPACE ADMINISTRATION

WASHINGTON, D.C. 20546

REPLY TO
ATTN OF: GP

OCT 15 1973

TO: KSI/Scientific & Technical Information Division
Attention: Miss Winnie M. Morgan

FROM: GP/Office of Assistant General Counsel for
Patent Matters

SUBJECT: Announcement of NASA-Owned U.S. Patents in STAR

In accordance with the procedures agreed upon by Code GP and Code KSI, the attached NASA-owned U.S. Patent is being forwarded for abstracting and announcement in NASA STAR.

The following information is provided:

U.S. Patent No. : 3,262,025
Cal/Tech

Government or
Corporate Employee : Pasadena, CA

Supplementary Corporate
Source (if applicable) : JPL

NASA Patent Case No. : XWP-01188

NOTE - If this patent covers an invention made by a corporate employee of a NASA Contractor, the following is applicable:

Yes No

Pursuant to Section 305(a) of the National Aeronautics and Space Act, the name of the Administrator of NASA appears on the first page of the patent; however, the name of the actual inventor (author) appears at the heading of column No. 1 of the Specification, following the words ". . . with respect to an invention of . . ."

Elizabeth A. Carter

Elizabeth A. Carter

Enclosure

Copy of Patent cited above



July 19, 1966

A. F. HILDEBRANDT ET AL

3,262,025

MAGNETIC-FLUX PUMP

Filed Nov. 29, 1961

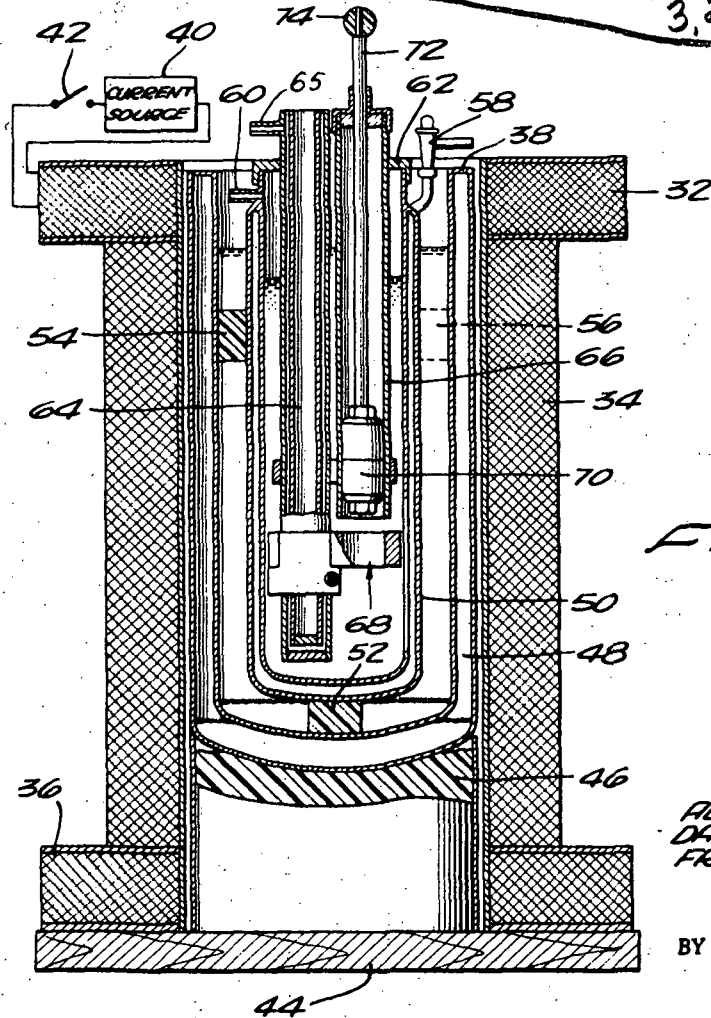
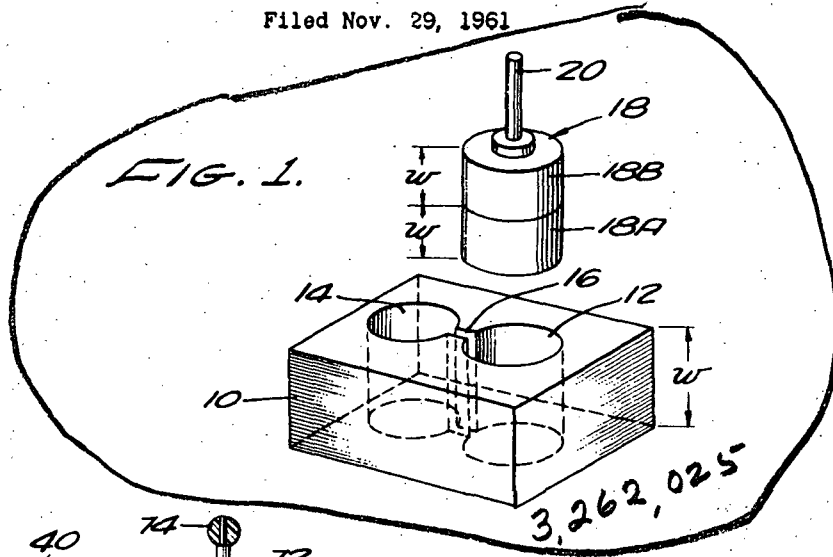

FIG. 2.

ALVIN F. HILDEBRANDT
DANIEL D. ELLEMAN
FRANK C. WHITMORE
INVENTORS

BY

Lyon & Lyon

ATTORNEYS

United States Patent Office

3,262,025

Patented July 19, 1966

1

2

3,262,025

MAGNETIC-FLUX PUMP

Alvin F. Hildebrandt, La Crescenta, Daniel D. Elleman, La Canada, and Frank C. Whitmore, Altadena, Calif., assignors to California Institute Research Foundation, Pasadena, Calif., a corporation of California
Filed Nov. 29, 1961, Ser. No. 155,596
4 Claims. (Cl. 317-158)

This invention relates to magnetic-flux pumps. The invention described herein was made in the performance of work under a NASA contract and is subject to the provisions of the National Aeronautics and Space Act of 1958, Public Law 85-568 (72 Stat. 426; 42 U.S.C. 2451), as amended.

This invention relates to a method and means for increasing the intensity of a magnetic field by transferring flux from one location to a location desired for said magnetic field and, more particularly, to improvements therein.

In an application by Alvin F. Hildebrandt and Daniel D. Elleman, which is assigned to a common assignee, there has been described and claimed a Magnetic-Flux Pump, Serial No. 155,597, filed November 29, 1961. The device described includes a pair of communicating cavities formed in a block of superconducting material. A piston, also made of superconducting material, is dimensioned to be insertable into one of the cavities and to substantially fill said cavity. Magnetic flux is first trapped in the cavities by establishing a magnetic field therein while the superconducting material is above the superconducting transition temperature and thereafter reducing the temperature below the transition value; then the exciting magnetic field may be removed. By inserting the piston into the cavity, the trapped flux is displaced therefrom and moved to the other cavity through the slot, where it is added to the field already present. By varying the ratios of the areas of the two cavities, it is possible to produce a field having much greater flux density in the second or smaller cavity to which the flux is transported.

This invention is directed to an improvement in said apparatus whereby the magnetic-field intensity which is established by the apparatus described may be still further increased without expenditure of additional magnetomotive energy.

Accordingly, an object of this invention is the provision of an improved magnetic-flux-pump apparatus.

Another object of this invention is the provision of a novel arrangement for establishing a magnetic field in a desired region by a mechanical flux transfer.

Still another object of this invention is the provision of a simple and useful arrangement for building up a magnetic field which does not employ an increased external electrical current in the buildup.

These and other objects of this invention are achieved in an arrangement, as briefly described above, wherein two cavities communicating with each other through a slot are formed in a block of material which has the property of superconductivity below a predetermined temperature. A piston is provided for insertion into one of these cavities. The piston is effectively made of two parts: One part is made of a material having the property of superconductivity and is sufficiently large to be insertable into one of the cavities and to substantially fill it; the other part is made of a ferromagnetic material, such as iron, and is also sufficiently large to substantially fill the cavity.

At the outset, with the part of the piston made of the ferromagnetic material in a cavity and with the temperature of all the material above the critical value at which the material can go superconducting, a magnetic

field is established through the cavities which extends parallel to the axis of the cavities. The superconducting material is then reduced in temperature below the critical value, and the magnetic field being applied to the cavities may then be removed. However, magnetic flux is trapped, by reason of the perfect conductivity, in the cavity in which the ferromagnetic piston is inserted and also in the other cavity. Because of the use of the piston made of ferromagnetic material, the flux which is trapped in that cavity is much greater than is trapped in the absence of a piston of ferromagnetic material. The piston is then actuated to displace the piston portion made of ferromagnetic material and to replace it with the piston portion made of superconducting material. This effectively drives the flux out of this cavity and through the slot into the other cavity, where it is added to the flux previously trapped therein. By varying the ratio of the cavity areas, the flux field density in the second or smaller cavity may be made extremely high. Provision may be made to use the increased-intensity flux field by inserting a tube in the cavity, which acts as a thermal shield and yet affords access thereto.

The novel features that are considered characteristic of this invention are set forth with particularity in the appended claims. The invention itself, both as to its organization and method of operation, as well as additional objects and advantages thereof, will best be understood from the following description when read in connection with the accompanying drawings, in which:

FIGURE 1 is a view in perspective of the essential structure of the embodiment of the invention;

FIGURE 2 is a cross-sectional view illustrating the embodiment of the invention inside of a Dewar flask.

It is known that when certain metals are cooled below a very low characteristic temperature they exhibit properties such as an abnormally high electrical conductivity and an almost perfect diamagnetism (the Meissner effect)—that is, the magnetic permeability is reduced practically to zero. In accordance with this invention, advantage is taken of the substantially infinite electrical conductivity effect for the purpose of transferring flux from one region to another to thereby increase the magnetic flux existing in such other region.

FIGURE 1 shows a structural arrangement for effectuating the flux transfer. The equipment essentially includes a block 10 of material which has the property that when it is cooled below the critical temperature it becomes superconducting. There are two cavities, respectively 12, 14, separated by a slot 16, machined through the block. The cavities preferably have a cylindrical shape, and the slot 16 is quite narrow. The area of the cavities 12, 14 may be made equal to each other, or the area of the cavity 14 may be made smaller than the area of the cavity 12, depending upon the field intensity desired in the cavity 14.

A piston 18 is provided which can be removably inserted into the cavity 12. The piston is made of two parts: The first 18A is made of a ferromagnetic material, such as iron, and has the dimensions such that when it is inserted into the cavity 12 it will completely fill that cavity; the other part 18B of the piston 18 consists of superconducting material and also is dimensioned to be insertable into the cavity 12 and to completely fill such cavity when inserted therein. The piston 18 is mounted upon a rod 20 which enables actuation of the piston from outside of apparatus, such as a cryostat or a Dewar flask, which is used to reduce the temperature of the superconducting material to the value at which it becomes superconducting.

The operation of the invention is as follows: First, the portion of the piston 18A is inserted into the cavity 12, completely filling it. Then, a magnetic field is applied

to the block 10, while it is above the critical temperature. The magnetic field is applied by a source (not shown here) such that the lines of flux in that field extend parallel with the axis of the cavities 12, 14. The effect of the ferromagnetic material 18A is to concentrate flux within the cavity 12 and to provide a flux density which is in excess of that achievable when the cavity 12 is only filled with air. Using a ferromagnetic piston increases the flux which is trapped by a factor which depends on geometry and on the magnetic permeability of the material used. In the previously mentioned application for a Magnetic-Flux Pump, by Hildebrandt et al., initially the cavity 12 was only filled with air.

After the magnetic field has been established, the block of superconducting material 10, as well as the portion of the piston 18 which is superconducting, are cooled below their critical temperatures. At this time the external magnetic field may be removed. However, due to the Meissner effect, the superconducting material effectively traps the magnetic flux which extends through the portion of the piston 18A and through the cavity 14, by the mechanism of currents being induced in the walls of the superconducting block 10, to maintain the magnetic field as it was at the time that the external magnetic field was removed. At this time, the piston 18 is actuated to remove the portion 18A and substitute instead the portion 18B. Since the portion of the piston 18B is superconducting, it displaces the trapped magnetic flux which existed in the cavity 12 into the cavity 14. As a result, there is a considerable increase in the magnetic-field intensity which exists in the cavity 14. Any experiments, calibrations, or measurements desired may be made within the intense magnetic field existing in the cavity 14.

FIGURE 2 is a cross-sectional view of a Dewar flask holding an embodiment of the invention, which illustrates how the invention may be operated within the flask and yet permit access to the cavity 14 for the purpose of working within the increased magnetic field existing therein. This apparatus includes three magnetic coils, respectively 32, 34, 36, which are oriented around a Dewar flask 38, in order to provide a magnetic field with lines of flux which pass through the cylindrical cavities along the axis of these cavities. A current source 40 supplies current to the magnetic-field coils when a switch 42 is actuated. The magnetic-field coils and the Dewar flask are supported upon a wooden base 44.

The Dewar flask 38 is actually supported above the base by a thermal insulating material 46, such as tar. The flask has an outer container 48, which surrounds an inner container 50. The space between the inner and outer containers, when it is desired to reduce the temperature of the apparatus contained within the inner container, may be filled with liquid nitrogen.

The inner container is supported within the outer container by means of Teflon spacers, respectively 52, 54, and 56. It will be noted that the walls of the inner and outer containers are actually double walls, and these walls enclose a space from which the air is removed. These two vacuum spaces serve as thermal insulating barriers. Provision is made for affording access to the space provided by the inner container walls for removing any gaseous helium which may seep into the vacuum space. This includes an opening to which connection is made by way of a valve 58 and another opening 60, to which the vacuum pump may be connected. Liquid helium may be poured into the container space within the inner Dewar walls.

A suitable cap 62 is provided for covering the inner and outer Dewar containers. However, an opening is provided in this cap for enabling external control of the flux-pump apparatus and also for enabling access to the region of the increased flux field which is established in the inner Dewar space.

The flux-pump apparatus is enclosed in a single-wall

tube which is long enough to extend outside of the Dewar flask, which permits any required operation of the apparatus, permits the apparatus to be cooled below the critical temperature, and yet does not interfere with the operation thereof. A double-wall cylinder 64 extends through the cover and affords access to magnetic-field region. The magnetic-pump apparatus includes a body 68, which may be of niobium material or of lead, which has two cylindrical chambers with a communicating slot formed therein, as shown in FIGURE 1 of the drawings. Provision is made for supporting this body 68 within the Dewar flask.

A piston 70 which, as was described in connection with FIGURE 1, has one portion made of iron and the other portion made of niobium, with both portions large enough to fill one of the cylindrical cavities, is attached to a shaft 72. The shaft extends outside of the Dewar flask to a handle 74.

In operation, first, the switch 42 is closed, enabling the magnetic coils to establish a magnetic field into the Dewar flask containing the flux-pump apparatus. At this time, the temperature of the niobium block is above the critical temperature. The piston 70 is inserted in the cavity of the niobium block, so that the iron portion of the piston fills this cavity. It is indicated at this time that the Dewar flask need not contain the cooling liquids, or may only have the liquid helium in the outer container portion. The cooling liquids are then added, and the niobium material is permitted to attain a temperature at which it becomes superconducting.

The switch 42 is then opened, collapsing the field established by the coils, but magnetic flux is trapped by the superconductor. Thereafter, the handle 74 is actuated to move the iron portion of the piston out of the cavity and the niobium portion of the piston into the cavity. The flux in the cavity is thereby transferred to the other cavity. Access is afforded to such other cavity by the thermal insulating cylinder 64 which extends into such other cavity from outside the Dewar flask. The double walls of the cylinder 64 have a vacuum therebetween, serving to act as a thermal insulator. It should be noted that access is had to this vacuum by way of a port opening 65, also for the purpose of removing any helium which may find its way into this vacuum.

The use of the ferromagnetic portion of the piston increases the amount of flux which may be trapped in the cavity, and thus, by reducing the area of the second cavity relative to the first cavity, or cavity into which the piston is inserted, one may obtain by the use of this invention an extremely strong magnetic field.

There has accordingly been described and shown herein a novel and useful arrangement for pumping magnetic flux from one cavity to another, whereby a flux field may be established in the second cavity, having an intensity determined by the ratio of the dimensions of the two cavities.

We claim:

1. A magnetic-flux pump comprising walls defining a first and second cavity separated by a slot, said walls being made of a material having superconducting properties when below a critical temperature, a body having a first portion made of a material having superconducting properties when below a certain temperature and a second portion made of a ferromagnetic material, said first and second portions of this body each being sufficiently large to substantially fill said first cavity and to be slidably insertable thereinto, means for supporting said first and second portions of said body adjacent one another for successive insertion of said second portion into said first cavity before cooling below said critical temperature and for insertion of said first portion into said first cavity after cooling below said critical temperature.

2. A magnetic-flux pump as recited in claim 1 wherein said first portion of said body is made of niobium metal and said second portion of said body is made of iron.

5

3. A magnetic-flux pump comprising walls defining a first and second cavity separated by a slot, said walls being made of a material having superconducting properties when below a certain temperature, a piston for insertion into said first cavity, said piston having a first portion made of a ferromagnetic metal and a second portion made of a material having superconducting properties when below a critical temperature, said first and second portions of said piston each being dimensioned to be slidably insertable successively into and to substantially fill said first cavity, means for inserting said first portion of said piston into said first cavity, means for establishing a magnetic field through said first and second cavities substantially parallel to said walls while said walls are at a temperature above said critical temperature, means for cooling said walls and said second portion of said piston until they are below said critical temperature, means for inactivating said means for establishing a magnetic field, and means for replacing said first portion of said piston by said second portion of said piston within said first cavity whereby flux is transferred into said second cavity which previously passed through said first portion of said piston.

4. An improved piston for a magnetic flux pump of the type comprising a body made of material having the property of superconduction below a critical temperature, and having two spaced openings therethrough in a slot therebetween for enabling communication between said openings, one of said openings being cylindrical in shape, means for establishing a magnetic field within said

6

cylindrical opening, means for cooling said body below the critical temperature, and means for inactivating said means for establishing a magnetic field; said improved piston comprising two piston sections, each of which alone substantially fills said cylindrical cavity and is slidably insertable therein, said two piston sections being joined at one end to have a common axis, one of said sections being made of ferromagnetic material, the other of said sections being made of material having the property of superconduction below a critical temperature, means for inserting said ferromagnetic material section within said cylindrical cavity when said magnetic field is established therein, means for cooling said superconductive material section below its critical temperature together with said body of material, and means for moving said superconductive material section into said cylindrical opening in place of said ferromagnetic section.

References Cited by the Examiner

UNITED STATES PATENTS

2,916,615	12/1959	Lundburg	340—173.1
2,946,030	7/1960	Slade	336—155

BERNARD A. GILHEANY, *Primary Examiner.*

E. JAMES SAX, JOHN P. WILDMAN, JOHN F. BURNS, *Examiners.*

G. HARRIS, JR., *Assistant Examiner.*