



NATIONAL AERONAUTICS AND SPACE ADMINISTRATION
WASHINGTON, D C 20546

REPLY TO
ATTN OF **GP**

OCT 15 1973

**TO: KSI/Scientific & Technical Information Division
Attention: Miss Winnie M. Morgan**

**FROM: GP/Office of Assistant General Counsel for
Patent Matters**

SUBJECT: Announcement of NASA-Owned U.S. Patents in STAR

In accordance with the procedures agreed upon by Code GP and Code KSI, the attached NASA-owned U.S. Patent is being forwarded for abstracting and announcement in NASA STAR.

The following information is provided:

U.S. Patent No. : 3,751,727
 International Latex Corporation

Government or
Corporate Employee : Dover, Del. 19901

Supplementary Corporate
Source (if applicable) : _____

NASA Patent Case No. : MSC-12,609-1

NOTE - If this patent covers an invention made by a corporate employee of a NASA Contractor, the following is applicable:

Yes No

Pursuant to Section 305(a) of the National Aeronautics and Space Act, the name of the Administrator of NASA appears on the first page of the patent; however, the name of the actual inventor (author) appears at the heading of column No. 1 of the Specification, following the words ". . . with respect to an invention of . . ."

Elizabeth A. Carter

Elizabeth A. Carter
Enclosure
Copy of Patent cited above

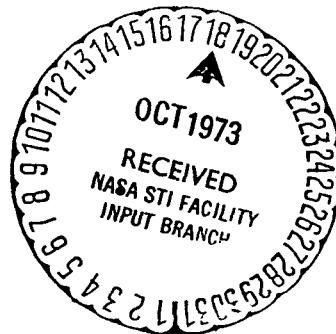

N73-32012

UNCLAS 18059

00/05

(NASA-Case-MSC-12609-1) SPACE SUIT Patent (International Latex Corp.)

21 P
CSCI 06Q

[54] **SPACE SUIT**
 [75] **Inventors: Leonard F. Shepard; George P. Durney; Melvin C. Case; A. J. Kenneway, III; Robert C. Wise; Dixie Rinehart, all of Dover; Ronald J. Besette, Wyoming, Richard C. Pulling, Dover, all of Del**

[73] **Assignee. Granted to The United States National Aeronautics and Space Administration Under The Provisions of 42 U.S.C. 2457, Washington, D C**

[22] **Filed: Aug. 5, 1968**

[21] **Appl. No. 750,031**

[52] **U.S. Cl. 2/2.1 A, 2/81, 128/1 A**

[51] **Int. Cl. A62b 17/00**

[58] **Field of Search 2/2, 2.1, 2.1 A, 2/6, 3, 81, 128/2 06, 2 05, 2 1, 283, 1.01, 142, 2 95, 285, 1 A**

[56] **References Cited**

UNITED STATES PATENTS

1,490,470	4/1924	Laubach	2/227
2,954,562	10/1960	Krupp	2/2 1 R
3,432,860	3/1969	Durney	2/2
2,404,020	7/1946	Akerman	2/2 1 X
2,749,558	6/1956	Lent et al	128/283 X
2,842,771	7/1958	Foti	2/2 1 UX
2,939,148	6/1960	Hart et al	2/2 1
2,966,155	12/1960	Krupp	2/2 1 X
3,000,014	9/1961	White	2/2 1 X
3,067,425	12/1962	Colley	2/2 1 X
3,221,339	12/1965	Correale	2/2 1

3,286,274	11/1966	O'Kane .	2/2 1
3,315,272	4/1967	Olt et al	2/6 X
3,362,403	1/1968	Fleming et al	2/6 X
3,409,007	11/1968	Fuller	128/2 06
3,463,150	8/1969	Penfold	2/2 1 X

FOREIGN PATENTS OR APPLICATIONS

957,085	5/1964	Great Britain	2/2 1 R
957,688	5/1964	Great Britain	2/2 1
666,671	9/1964	Italy	2/2 1

OTHER PUBLICATIONS

International Science and Technology Publication, February 1967 (page 33 relied on), by M I Radnofsky

Primary Examiner—Jordan Franklin
Assistant Examiner—George H. Krizmanich
Attorney—Leonard Rawicz, Neil B Siegel and Marvin F. Matthews

[57] **ABSTRACT**

Disclosed is a pressure suit for high altitude flights and particularly space missions. The suit is designed for astronauts in the Apollo Space Program and may be worn both inside and outside a space vehicle, as well as on the lunar surface. It comprises an integrated assembly of inner comfort liner, intermediate pressure garment, and outer thermal protective garment with removable helmet and gloves. The pressure garment comprises an inner convoluted sealing bladder and outer fabric restraint to which are attached a plurality of cable restraint assemblies. It provides versatility in combination with improved sealing and increased mobility for internal pressures suitable for life support in the near vacuum of outer space.

11 Claims, 25 Drawing Figures

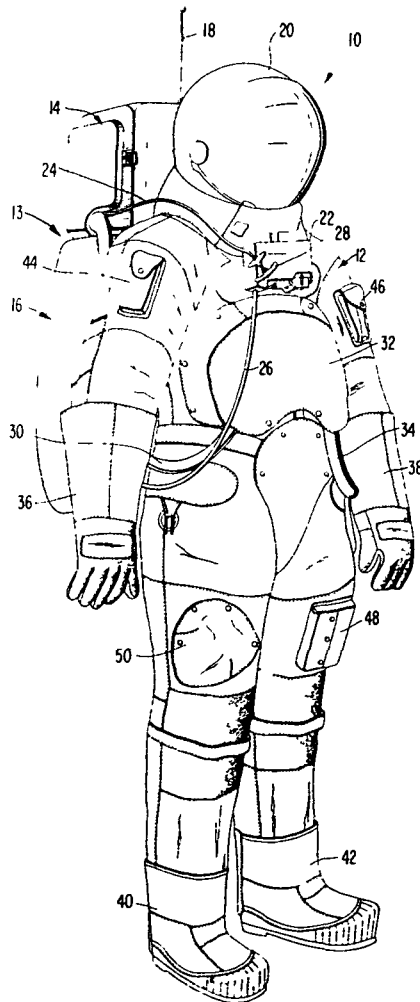

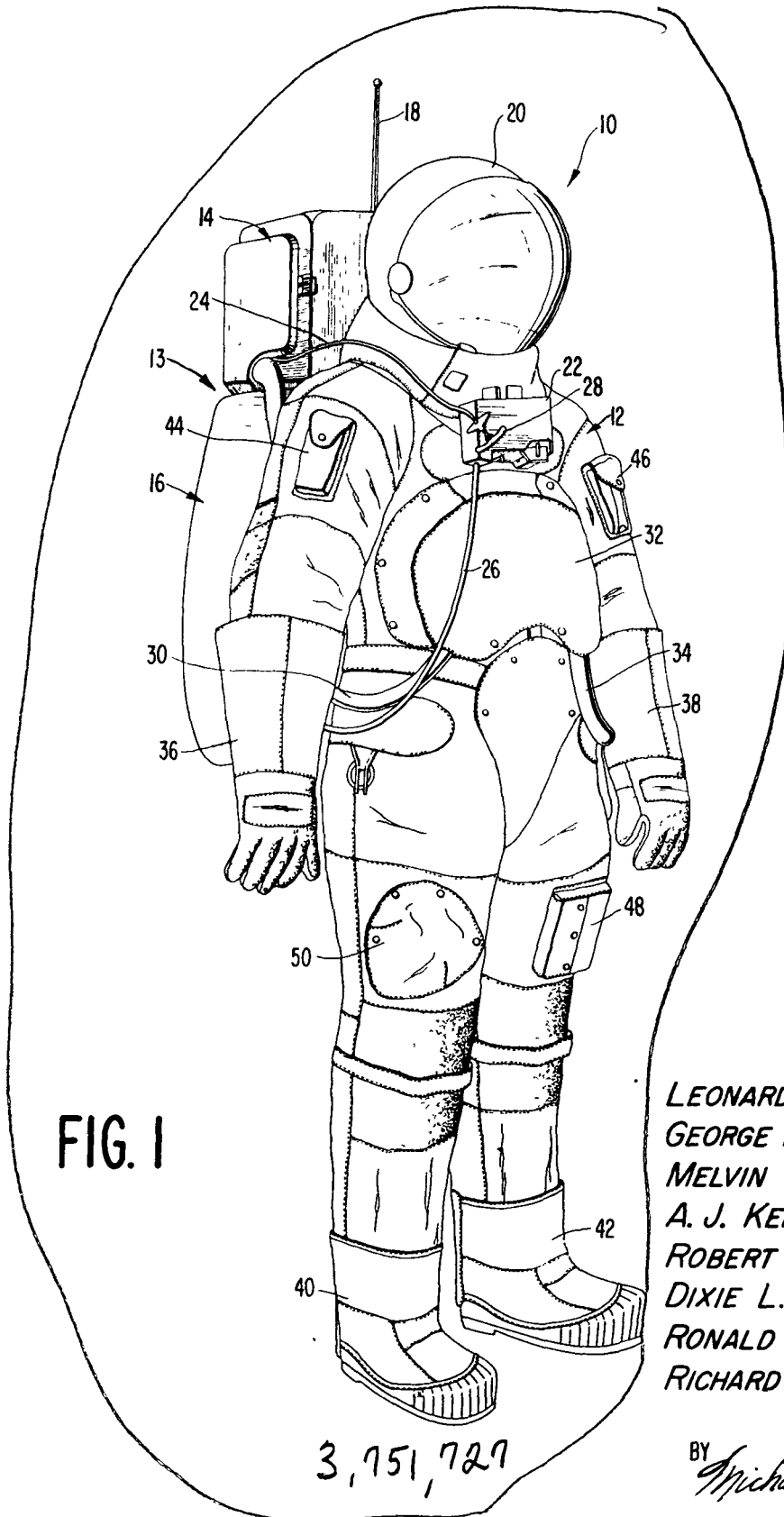

FIG. 1

INVENTORS

LEONARD F. SHEPARD
GEORGE P. DURNEY
MELVIN C. CASE
A. J. KENNEWAY III
ROBERT C. WISE
DIXIE L. RINEHART
RONALD J. BESSETTE
RICHARD C. PULLING

3,751,727

BY *Michael A. Sileo, Jr.*
ATTORNEY

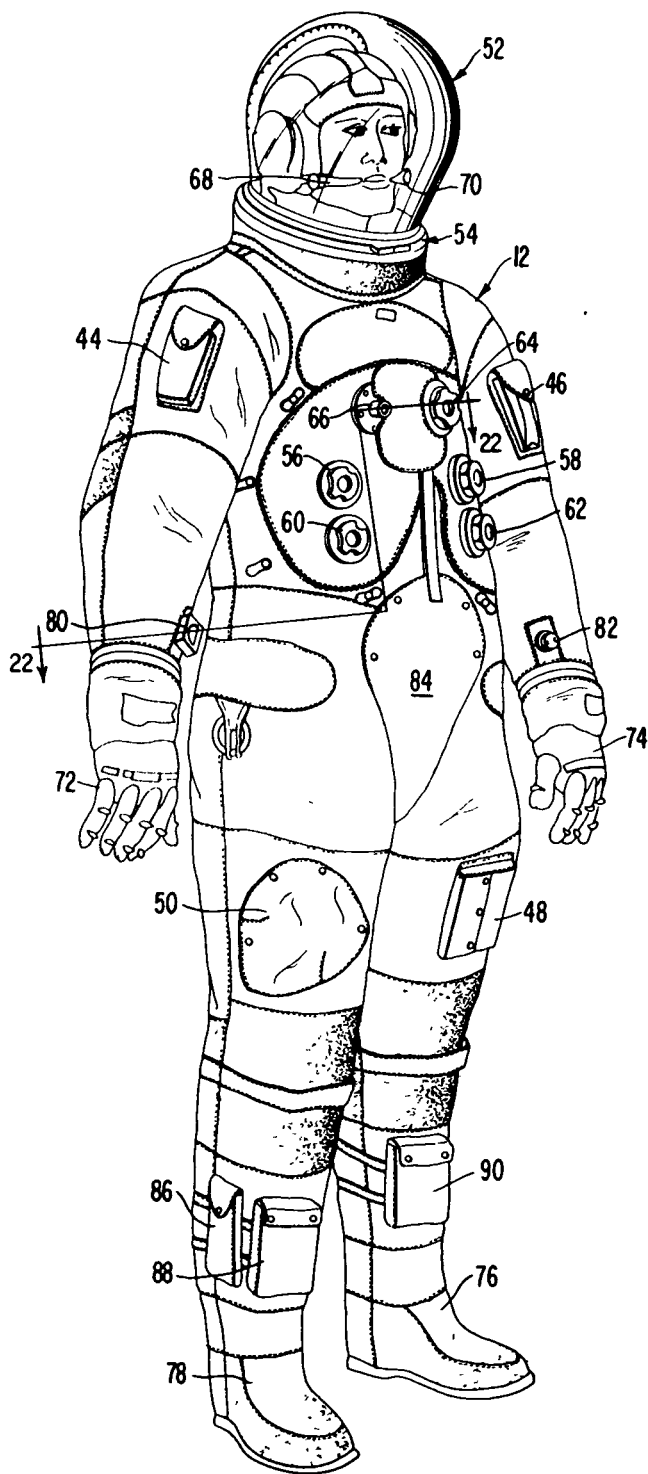

FIG. 2

PATENTED AUG 14 1973

3,751,727

SHEET 03 OF 10

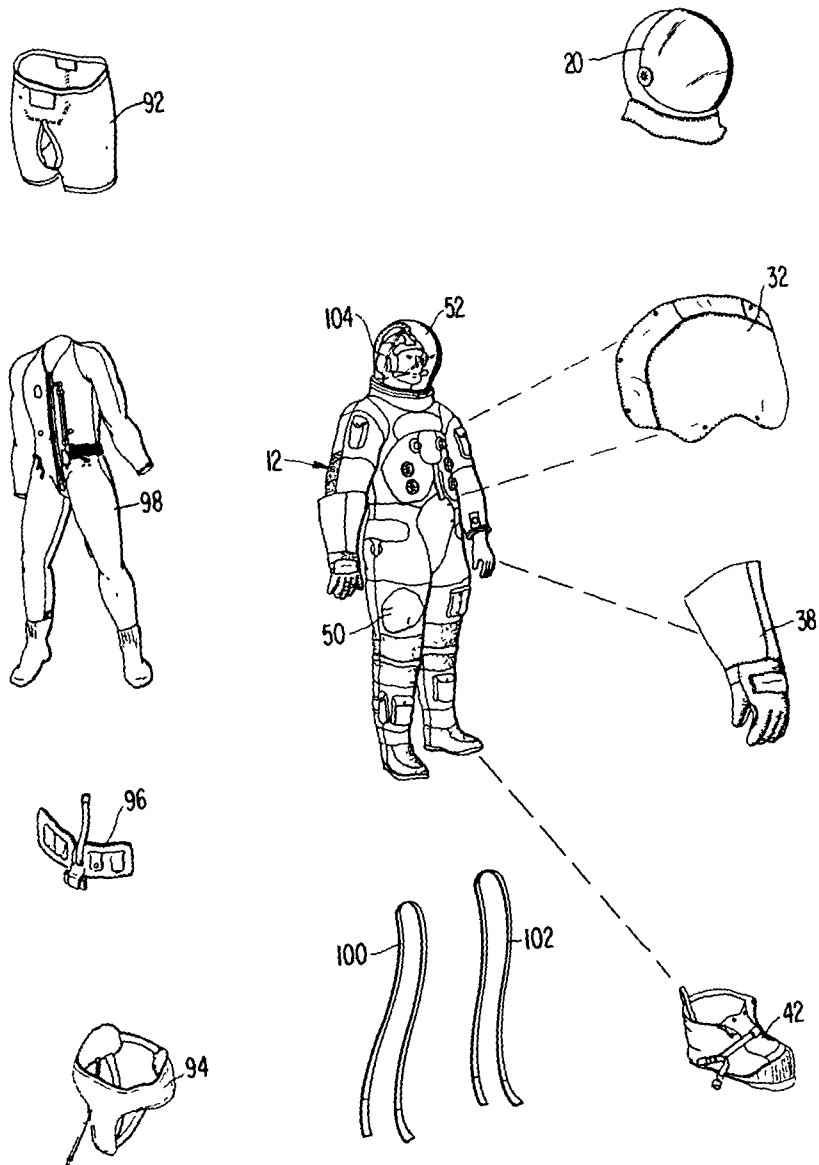

FIG. 3

PATENTED AUG 14 1973

SHEET 04 OF 10

3,751,727

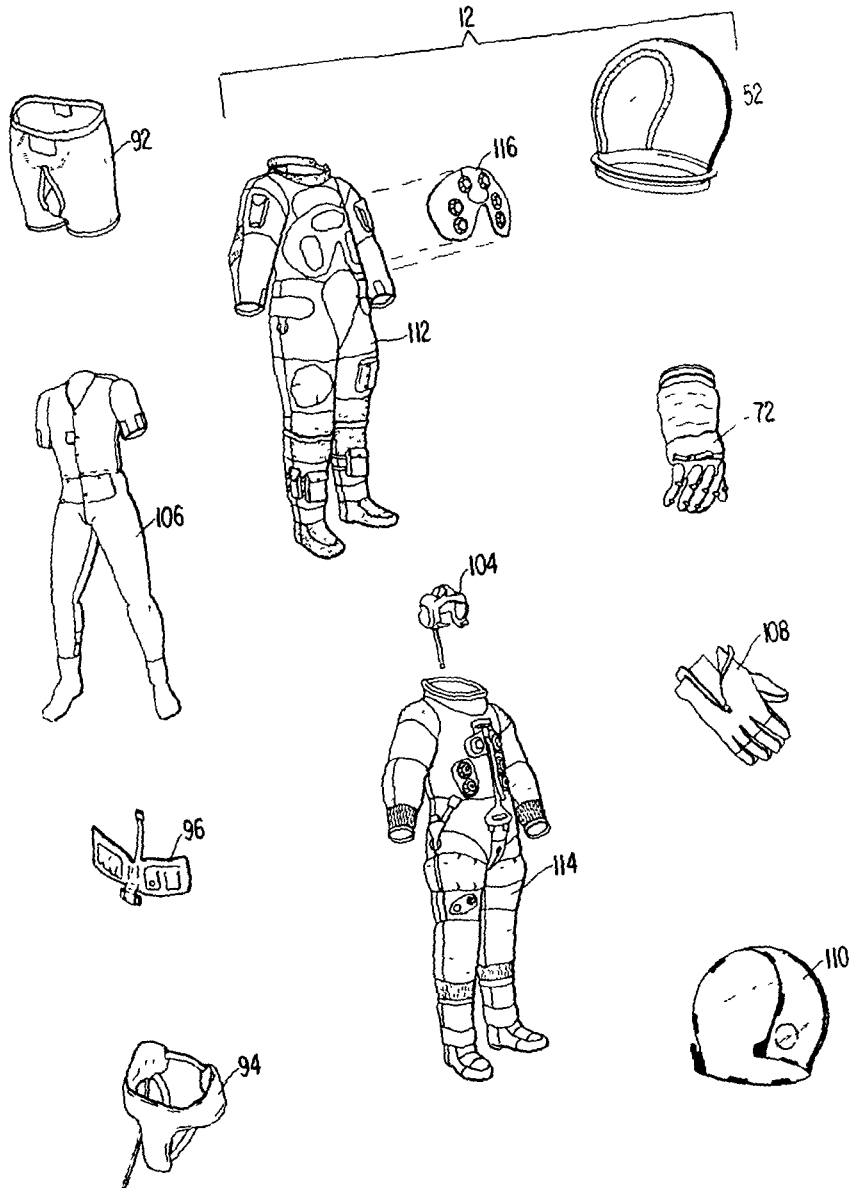

FIG. 4

FIG. 6

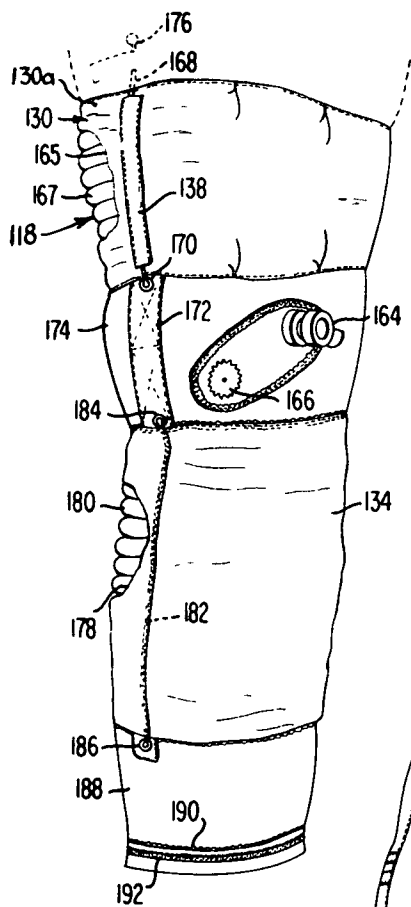

FIG. 5

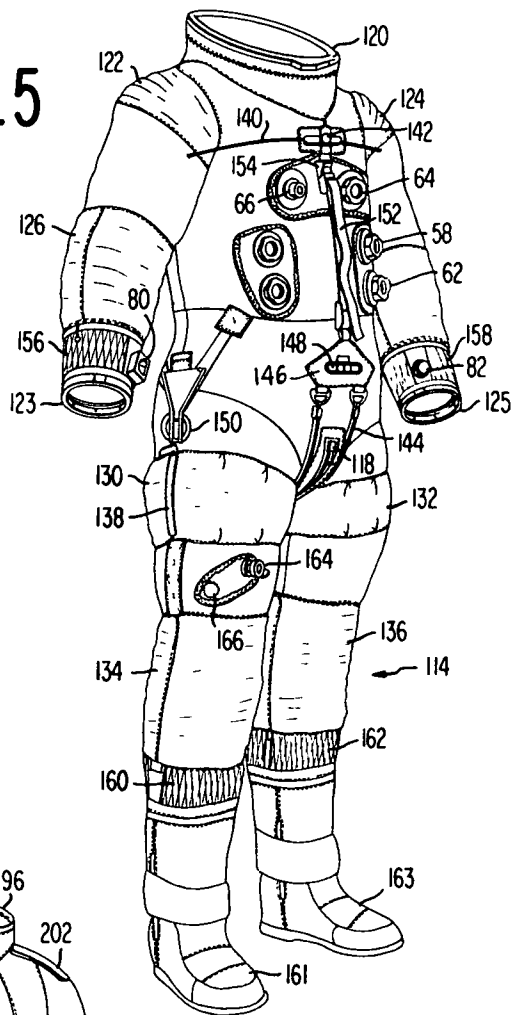
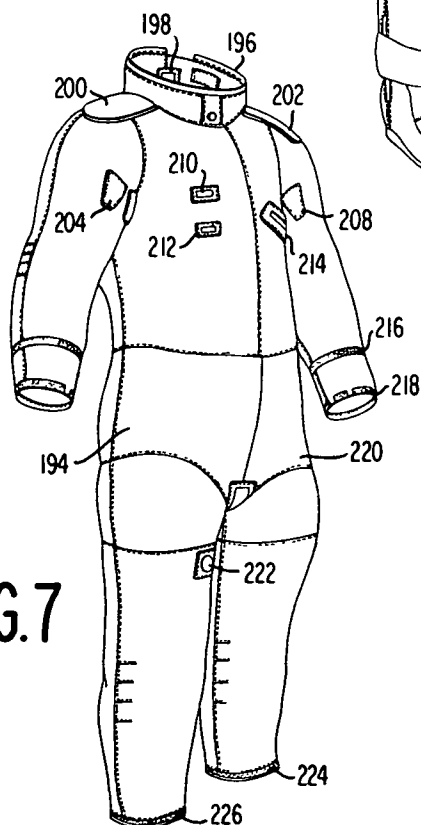

FIG. 7



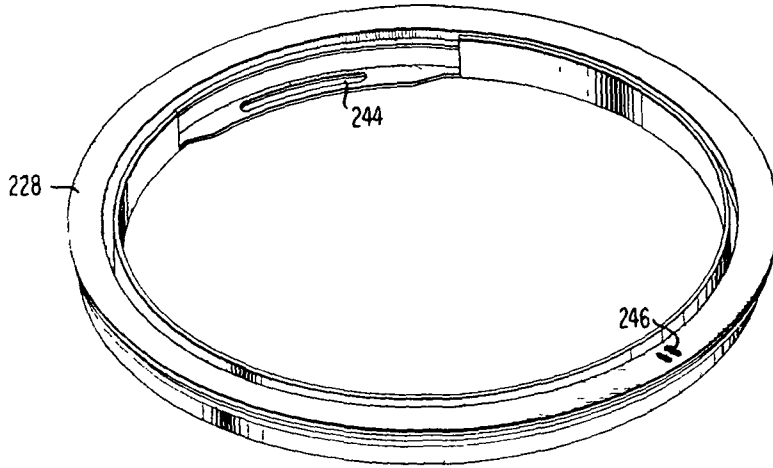

FIG. 8

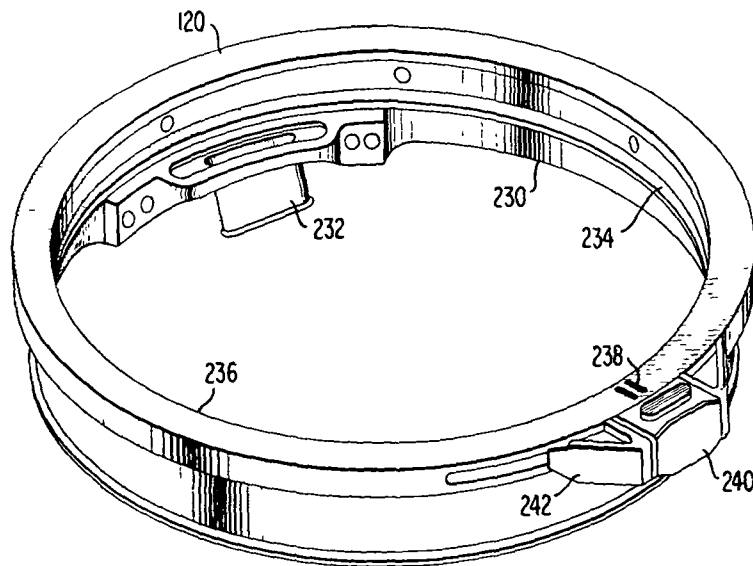

FIG. 9

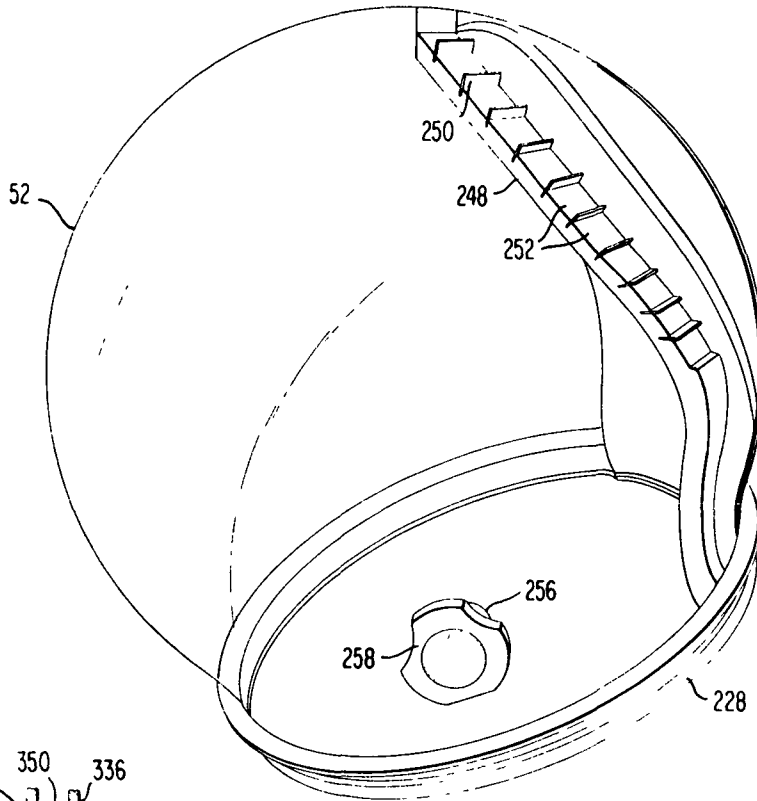

FIG. 10

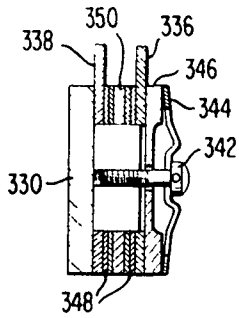

FIG. 17A

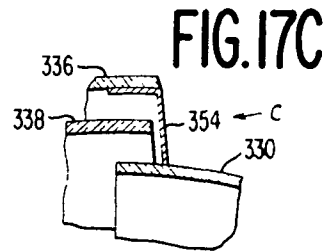

FIG. 17C

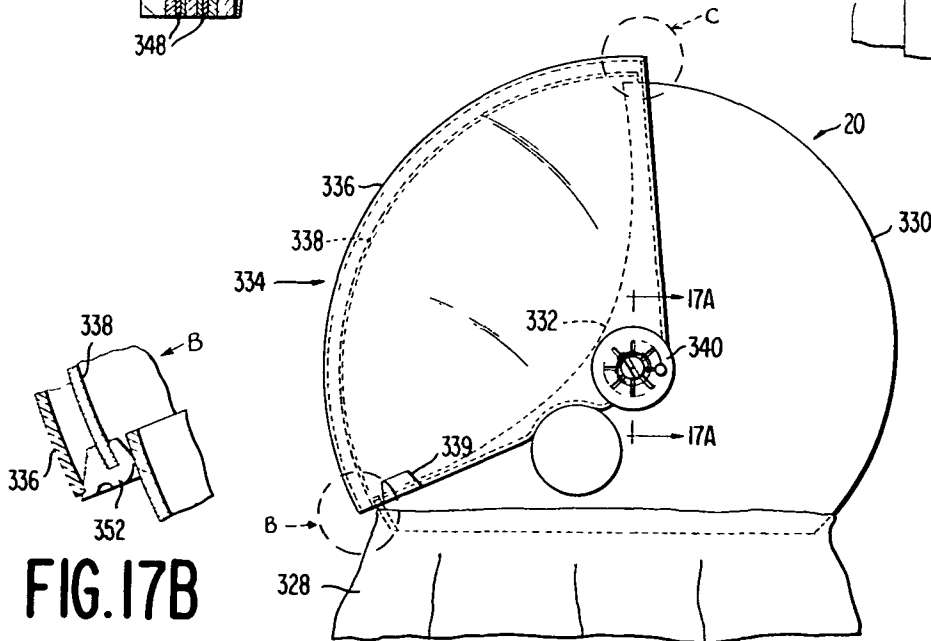

FIG. 17

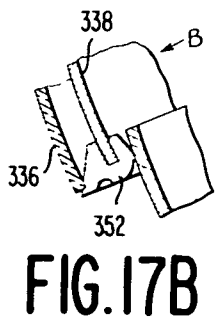

FIG. 17B

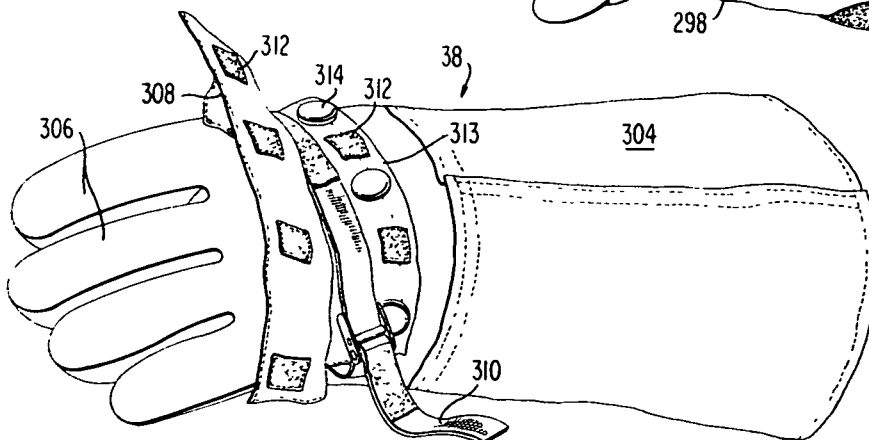
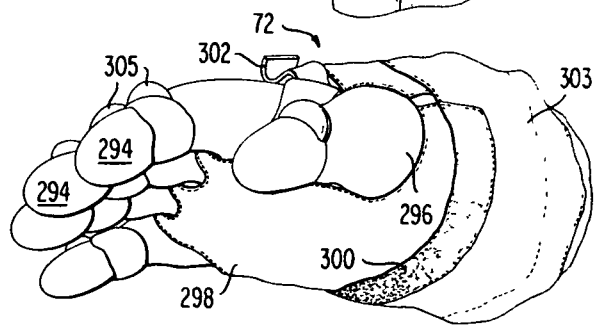
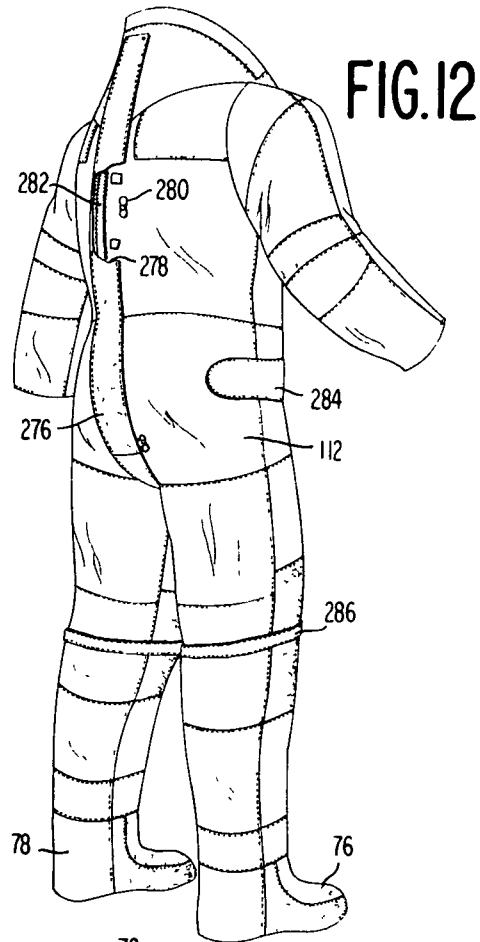
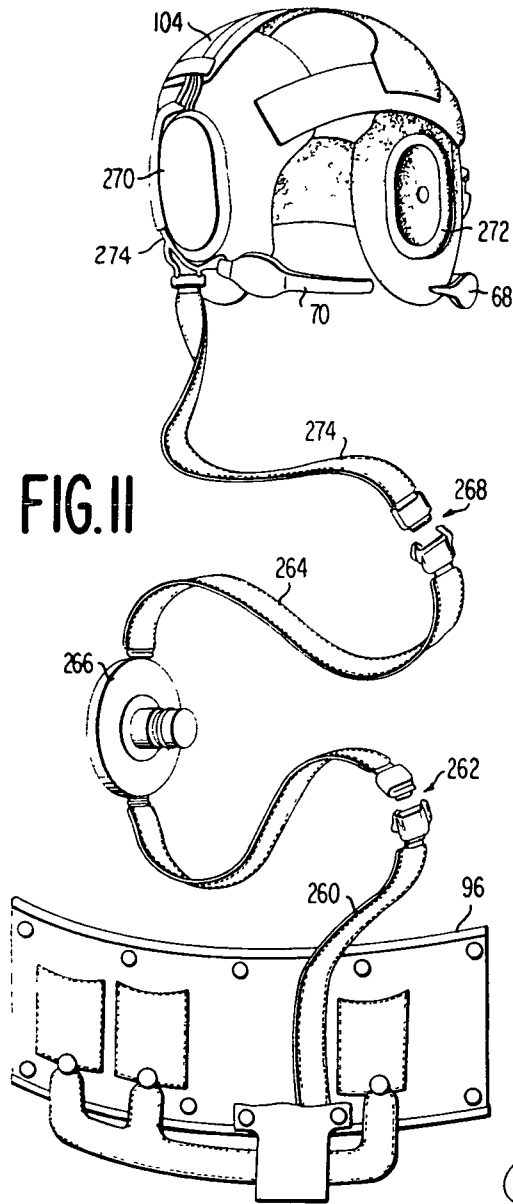

FIG. 15

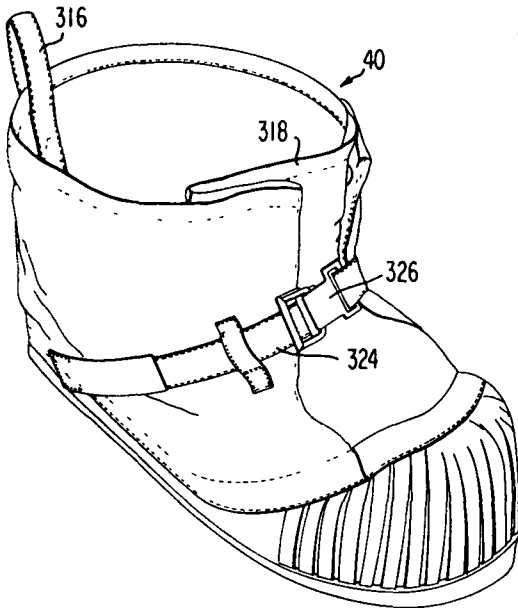
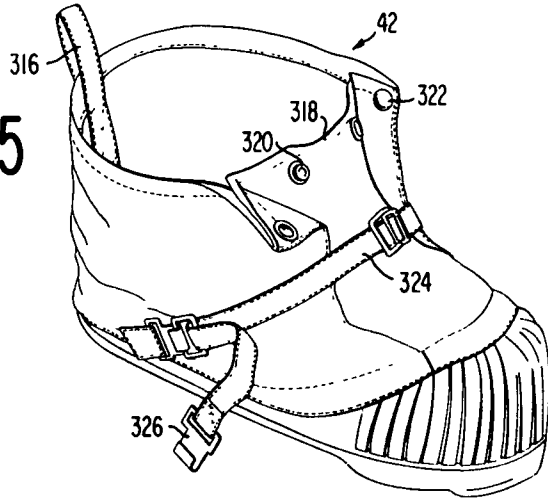

FIG. 16

FIG. 20

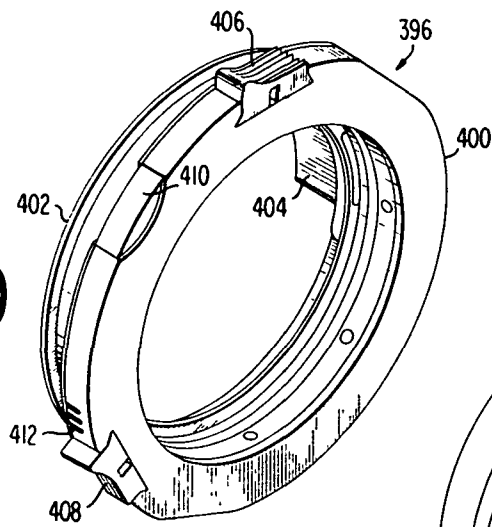
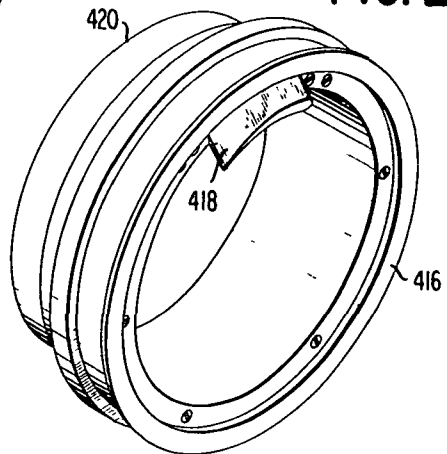

FIG. 21



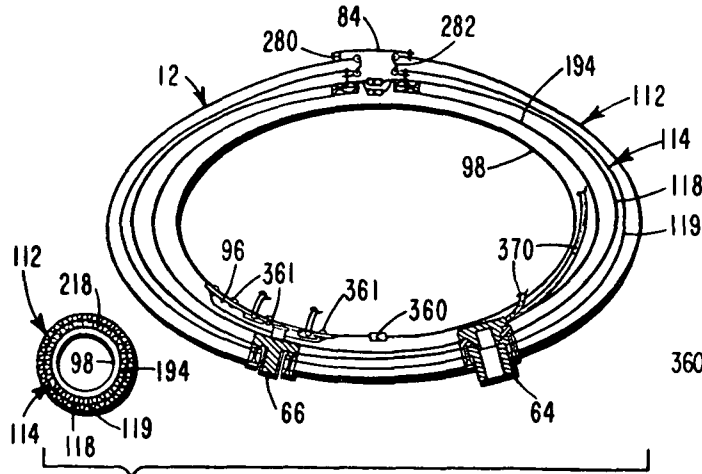

FIG. 22

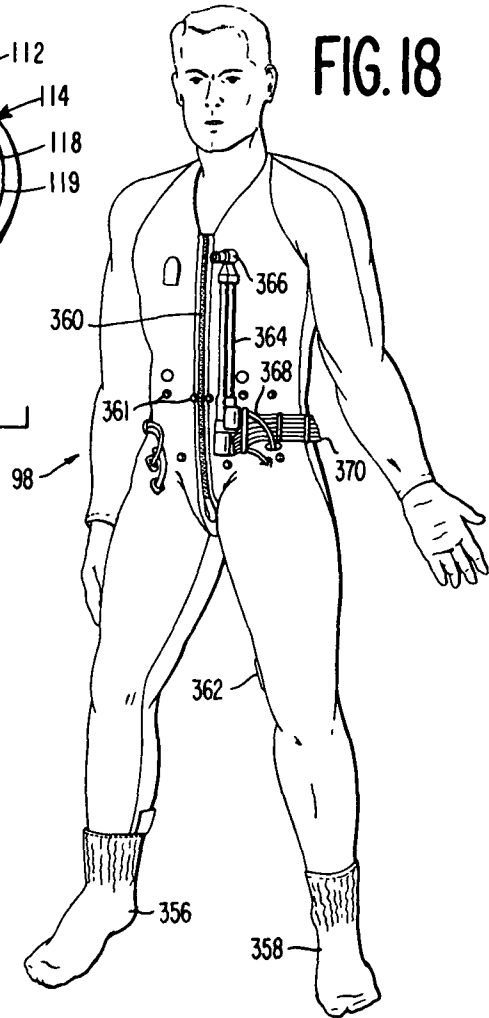

FIG. 18

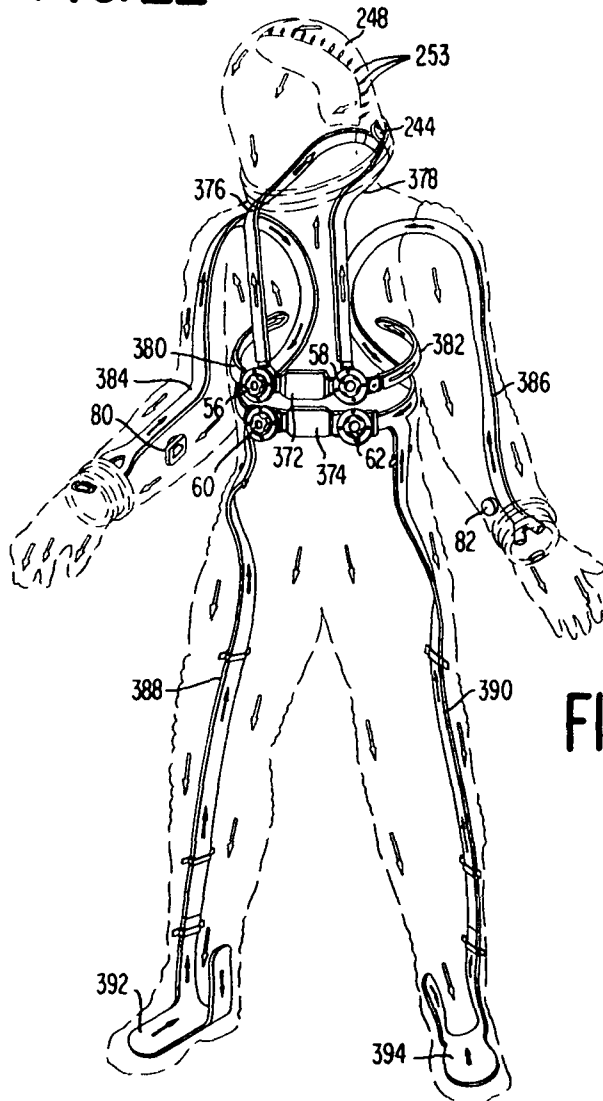

FIG. 19

1
SPACE SUIT

ORIGIN OF INVENTION

The invention described herein was made in the performance of work under a NASA contract and is subject to the provisions of Section 305 of the National Aeronautics and Space Act of 1958, Public Law 85-568 [72 Stat 435, 42 U.S.C. 2457]

This invention is directed to a pressure suit to be worn by human beings in a hostile environment, and more particularly is directed to a life support suit to be worn by U.S. astronauts in the Apollo Space Program. The suit is designed to provide life support not only within a space vehicle, but also during extravehicular activities including exploration of the lunar surface. It may also be used by aircraft pilots during high altitude flights.

The suit of the present invention, in conjunction with a unit strapped to the astronaut's back, is believed for the first time to provide a completely self-sustaining system which for a limited period of time enables the astronaut to freely perform extravehicular activities, such as external spacecraft corrective maintenance and lunar surface exploration. A primary feature of the space suit of this invention involves the retention of a pressurized atmosphere about the astronaut in the vacuum of free space, while at the same time providing significantly increased mobility, both in the torso and the limbs, so that the astronaut may freely move about and perform useful tasks. At the same time, the suit incorporates novel constructions and assemblies for permitting normal body functions, maintains a breathable atmosphere about the astronaut controlled both as to pressure and temperature, and affords significant protection from micro-meteoroids and other physical dangers the astronaut may encounter.

The suit comprises, as the principal component, an integrated three-garment assembly comprising an inner comfort liner, an intermediate pressure garment assembly providing a controlled atmosphere within the garment without excessively inhibiting astronaut mobility, and an outer insulating and protective layer referred to as an integrated thermal micrometeoroid garment. These three garments are integrally joined and are of anthropomorphic construction individually fitted to accommodate the dimensions of each astronaut. They are designed to cover the entire body in conjunction with removable gloves and a removable helmet. The suit of the present invention is worn over specially designed undergarments which cooperate with the suit, including helmet and gloves, to completely support normal life functions.

Versatility is built into the suit such that with a minimum of interchangeable parts the suit can be readily adapted to completely different astronaut missions. This versatility also makes possible increased comfort for an astronaut during a mission since it not only makes it possible for the astronaut to select the most comfortable and suitable combination for his particular task but certain elements of the space suit may be completely removed for increased comfort during times when they are not needed. For example, both the gloves and helmet are completely removable and may be taken off by the astronaut within the pressurized cabin of a space vehicle when it is not necessary to rely on the suit for life support. Finally, the suit is provided with a redundant pressurized life support gas connec-

2

tion for increased safety. All of this is incorporated in a unit which when completely assembled has a total weight, including helmet and protective shield, of only a little over 60 pounds.

It is therefore one object of the present invention to provide an improved space suit particularly designed to be worn by astronauts in the Apollo Space Program.

Another object of the present invention is to provide a pressurized suit and an associated assembly adapted to be worn by astronauts and high altitude aircraft personnel in a hostile and particularly low pressure environment.

Another object of the present invention is to provide a space suit particularly adapted with a minimum of modification for both intravehicular and extravehicular use and particularly designed to support human life during exploration of the lunar surface.

Another object of the present invention is to provide an improved pressurized space suit having improved gas sealing qualities and at the same time providing optimum mobility for the wearer.

Another object of the present invention is to provide a pressurized space suit assembly particularly designed to be completely self-contained for sustaining human life independent of any other life support source for periods of several hours. The suit is adapted to existing interface equipment and during intravehicular activity may be completely interfaced with the cabin life support system of a space vehicle.

These and further objects and advantages of the invention will be more apparent upon reference to the following specification, claims, and appended drawings, wherein:

FIG. 1 is a perspective view of the overall space suit and associated life supporting unit as provided for extravehicular activity and particularly lunar surface exploration;

FIG. 2 is a perspective view similar to FIG. 1 showing the suit alone, with extravehicular overshoes, gloves, and a helmet shield removed,

FIG. 3 is an exploded view showing the major components making up the extravehicular configuration of the space suit and undergarment construction of the present invention,

FIG. 4 is an exploded view similar to that of FIG. 3 showing the major components of the suit usable for intravehicular activities,

FIG. 5 is an enlarged perspective view of the suit with helmet and gloves removed and the integrated thermal micro-meteoroid garment omitted for the sake of clarity,

FIG. 6 is an enlarged view showing the thigh and upper right leg portion of the basic pressure garment assembly of FIG. 5;

FIG. 7 is a perspective view of the inner liner for the pressure garment assembly of FIG. 5,

FIG. 8 is a perspective view of the helmet neck ring for the space suit of this invention,

FIG. 9 is a similar perspective view of the suit neck ring adapted to be attached to the helmet neck ring of FIG. 8,

FIG. 10 is a perspective view of the transparent pressure helmet assembly for the space suit of the present invention;

FIG. 11 shows the space suit electrical harness,

FIG 12 is a perspective view showing the rear portion of the outer garment or integrated thermal micro-meteoroid garment of the space suit,

FIG 13 is a perspective view of one of the pressure gloves of the space suit,

FIG 14 is a perspective view of an extravehicular glove adapted to be worn over the glove of FIG 13 during extravehicular activities,

FIG 15 is a perspective view of the left lunar overshoe for the suit of the present invention,

FIG 16 is a perspective view similar to that of FIG 15 of the right lunar overshoe,

FIG 17 is a perspective view with enlarged pertinent cross sections (17A,17B,17C) showing the extravehicular visor assembly of the space suit,

FIG 18 is a perspective view showing an undergarment usable in the extravehicular configuration, i.e., the liquid cooling garment,

FIG 19 is a perspective view of the pressurization and ventilation life support pressure gas system for the suit of the present invention,

FIG 20 is a perspective view of one of the locking rings at each wrist of the suit;

FIG 21 is a similar view of a locking ring mounted on one of the gloves and adapted to lock to the wrist ring of FIG 20, and

FIG 22 is a schematic cross sectional plan view through the torso and right wrist portion of the suit taken along line 22—22 of FIG 2.

Referring to the drawings, the self-contained life supporting system of the present invention is generally indicated at 10 in FIG 1 and illustrates how the astronaut will appear as he explores the surface of the moon. The system of FIG 1 is designed to permit the astronaut substantial mobility and to make him completely self-sustaining for periods of as much as 6 hours or more outside the space vehicle and particularly on the lunar surface.

The assembly 10 comprises as its major component a space suit, generally indicated at 12, to the back of which is strapped a lunar module 13 including an oxygen purge system, generally indicated at 14, and a portable life support system beneath it containing water, filters, battery, etc., is generally indicated at 16. Communication with other astronauts and with the space ship is maintained by way of an antenna 18.

As illustrated in FIG 1, the suit 12 comprises a removable helmet over which is mounted an extravehicular visor assembly 20 to protect the astronaut both from physical injury or damage and from the intense rays of the sun outside the space vehicle. Mounted on the astronaut's upper chest is a portable life support system control box 22 which is connected by line 24 to the oxygen purge system 14 and by a second line 26 to the portable life support system 16, both mounted by straps on the astronaut's back. During extravehicular activity, the suit is periodically purged by the astronaut's manual operation of an oxygen purge system actuator 28, mounted on the control box 22. Oxygen flow to the interior of the suit is by way of a system umbilical 30 which connects from the oxygen purge system 14 to the chest of the space suit 12 in a manner more fully described below. The oxygen connections on the chest of the suit are closed off by a connector cover 32 in FIG 1. Other connections to the apparatus mounted on the astronaut's back providing for communication, ventilation and liquid cooling are from additional connectors

beneath cover 32 by way of umbilicals 34. For extravehicular activity, the astronaut is provided with a pair of extravehicular gloves 36 and 38 and a pair of lunar overshoes 40 and 42 which cooperate to protect extremities from the hazards of space and particularly provide protection by way of thermal insulation from intense sunlight and provide physical protection from micro-meteoroid bombardment. The outer garment illustrated in FIG 1, referred to as the integrated thermal micro-meteoroid garment, is a metallized white or light colored fabric and is designed to provide thermal insulation and micro-meteoroid protection.

The suit is provided with a plurality of pockets so that the astronaut will have ready access to everything that he may need outside the vehicle. Just below one shoulder of the space suit 12 is a sunglasses pocket 44. A similar pocket 46 adjacent the other shoulder is a pen-light pocket. A utility pocket 48 is provided in the upper left leg. Finally, the upper right leg of the integrated thermal micro-meteoroid garment or outer suit garment is provided with a flap 50 which not only houses the suit donning lanyard, but also is an access flap for a urine collection and transfer assembly, for a dosimeter connection, and includes a self-sealing patch for bio-medical injections.

FIG 2 shows the astronaut as he might appear inside the space vehicle either before or after extravehicular activity. In FIG 2, the lunar module 13 has been removed from the astronaut's back, and helmet shield 20 has been removed as have the extravehicular gloves and lunar overshoes. Also, the front chest cover has been removed to expose the various connectors for establishing fluid and electrical communication to the interior of the suit.

Covering the astronaut's head is a pressure helmet assembly 52 including a shell formed of a transparent polycarbonate material. The helmet is attached to the neck of the suit by an interlocking metal ring assembly, generally indicated at 54, one ring of which is attached to the helmet and the other to the suit neck. A neck dam (not shown) may be inserted into the neck of the suit to act as a water shield for re-entry or other purposes when it is believed that the astronaut may land in the ocean or otherwise be exposed to a water environment.

In FIG 2, the connector cover is removed exposing four gas connections comprising two upper inlet connections 56 and 58 and two lower outlet connections 60 and 62. These connections permit life support gas, such as oxygen, to be passed into and out of the space suit which (1) provides oxygen for the astronaut to breathe, (2) maintains the interior of the suit pressurized, and (3) provides ventilation over the astronaut's entire body. Connector 64 on the astronaut's chest is for circulating cooling liquid, such as water, through the interior of the space suit which is only required during extravehicular activity, while connector 66 provides for electrical connection to the interior of the space suit. Two of the lines passing through electrical connector 66 lead to a pair of microphones 68 and 70 located adjacent the astronaut's mouth by means of which he can communicate with other astronauts and with communication equipment on board the space vehicle.

Removal of the extravehicular gloves 36 and 38 of FIG 1 exposes in FIG 2 the pressure gloves 72 and 74. These gloves are formed in part from a rubberized fab-

ric and have sufficient flexibility so that the astronaut can perform a variety of intricate manipulations with the fingers and hands. Removal of the lunar overshoes 40 and 42 of FIG 1 exposes in FIG 2 the boots 76 and 78 which are formed integral with the remainder of the space suit. On the right-hand arm above glove 72 is a pressure gage 80 by means of which the astronaut is able to monitor the pressure within the suit and at approximately the same location on the left arm is a pressure relief valve 82 adapted to open at a predetermined pressure to automatically relieve the pressure within the suit when it becomes too high. The suit is entered through a slide fastener or zipper passing over the back from just beneath the neck downwardly between the shoulders and through the crotch to the front of the suit, which fastener is covered by an entrance slide fastener flap 84. Finally, strapped to the astronaut's legs are a scissors pocket 86, a checklist pocket 88, and a data list pocket 90.

FIG 3 is an exploded view showing the elements of the space suit and undergarments of the present invention used for extravehicular activity. In addition to the suit proper, hereafter referred to as the pressure garment assembly generally indicated at 12 in FIG 3, the astronaut wears beneath the pressure garment assembly a fecal containment subsystem 92 worn much in the manner of undershorts, a urine collection and transfer assembly 94, a bio-medical belt 96, and a liquid cooling garment 98 worn much in the manner of long underwear. The undergarments 92, 94, 96, and 98 are normally donned by the astronaut in the order in which they are numbered. Over the basic pressure garment assembly, the astronaut wears elements previously described, namely, the extravehicular visor assembly 20, connector cover 32, extravehicular gloves, such as glove 38, and lunar overshoes, such as overshoe 42. The suit is put on by the astronaut with the aid of a pair of removable donning straps 100 and 102, which after the suit has been donned are stored beneath the access flap 50. Within the helmet 52, the astronaut's head is surrounded by a communications carrier 104 on which are mounted the microphones previously described.

FIG 4 is an exploded view showing all the elements of the space suit forming the intravehicular configuration. That is, it is contemplated that at least one astronaut in the Apollo Program flights will remain in the space vehicle at all times. This astronaut does not need the extravehicular protection of the others and for this reason may wear a modified suit of the same basic construction, but with important modifications. In FIG 4, like parts bear like reference numerals, and it will be noted that the intravehicular configuration of FIG 4 is quite similar to the extravehicular configuration of FIG 3. The principal difference is that in place of the liquid cooling garment 98 illustrated in FIG 3, the astronaut wears a constant wear garment 106 beneath the pressure garment 12 very closely resembling a pair of long underwear. The constant wear garment 106 is optional and the astronaut may, if desired, wear the liquid cooling garment 98 of FIG 3 so that, in case of an emergency, he too will be prepared to go outside the vehicle where he will be exposed to intensive sunlight and the liquid cooling provided by the garment 98 is required. FIG 4 also shows various components of the basic pressure garment assembly, including the pressure helmet assembly 52 and pressure glove 72, previously described. Inside the vehicle, the astronaut may

slip a cover glove assembly 108 over the pressure glove 72 to protect it and may slip a helmet shield 110 over the pressure helmet assembly 52 to protect it from contact with the inside of the space vehicle. As previously mentioned, the basic pressure garment assembly 12 comprises an outer garment 112, previously referred to as the integrated thermal micro-meteoroid garment, which is attached to the pressure sealing and mobility providing garment, hereafter referred to as the torso limb suit assembly 114. Communications carrier 104 forms part of the torso limb suit assembly, whereas the micro-meteoroid garment 112 is provided with a removable chest cover 116.

FIG 5 is an enlarged perspective view of the torso limb suit 114 which, while shown separately, is worn integrally with an inner comfort liner described below and the outer micro-meteoroid garment 112, previously described.

The torso limb suit 114 of FIG 5 forms a basic component of the space suit of the present invention since, in conjunction with the helmet and gloves, it provides a life supporting environment for the astronaut and, more specifically, acts both as the pressure retaining sealing component for the suit and at the same time incorporates constructions and assemblies which provide for increased mobility. That is, when the space suit is inflated to an internal operating pressure in the neighborhood of 3 to 4 pounds per square inch, the space suit tends to expand and become rigid so that it is difficult for the astronaut to move about. In order to increase the astronaut's mobility, substantially constant volume bellows-like convolutes are provided at most of the suit joints and various cable and restraint assemblies are mounted to the exterior of the suit to permit the astronaut to bend and flex the suit joints and move about. Pressure sealing is effected by providing the suit with an inner rubberized fabric layer referred to as a bladder 118. Over the bladder are several layers of fabric forming a restraint layer 119 which protect the bladder and also aid in restraining it.

Referring to FIG 5, the helmet attaching ring is illustrated at 120 as secured to the neck of the space suit. A pair of covers 122 and 124 overlie a pair of constant volume shoulder convolutes which permit the astronaut to flex and bend the shoulder joints without undue effort when the suit is inflated. Similar covers 126 and 128 overlie constant volume convolutes provided in the suit adjacent the elbow. Covered convolutes are also provided at the hips or upper thigh as illustrated at 130 and 132 and at the knee joints as illustrated at 134 and 136.

Unless these constant volume convolutes are in some way restrained, they tend to elongate and expand under the internal pressure within the suit. Thus, the thigh convolute 167 is restrained against expansion by its cover 130 and is longitudinally restrained by a metal cable 168 attached at its upper end to a reinforced portion of the suit at the hip and at its lower end to a reinforcing patch adjacent the knee which cable is covered by a fabric wear sleeve or cable guide 138. It is understood that a similar cable provides restraint at hip joint 130 on the inside of the leg, as well as the outside, i.e., spaced about the astronaut's leg approximately 180° from the cable 138.

The shoulder restraint takes the form of a shoulder cable 140 which extends continuously from over the astronaut's breast bone through the shoulder assembly

adjacent convolute 122 across the astronaut's back and back through the other shoulder assembly adjacent convolute 124 to a shoulder cable disconnect 142. This cable restrains the shoulders and is continuous except for the two ends attached to the disconnect 142 which the astronaut, at his option, may open to disconnect cable 140 and remove the shoulder restraint should he so desire

Additional restraint is provided by a crotch wire assembly, partly illustrated at 144, which assists the astronaut in bending and other torso movements. One end of the crotch cable assembly 144 is attached to a reinforcing patch 146 having a loop 148 adapted to receive straps for supporting the lunar module 13 of FIG. 1. Lunar module support eyelets are also provided at each hip as illustrated by the eyelet 150. To assist the astronaut in bending forward and in sitting down, the front of the torso is provided with a block and tackle assembly including a torso adjusting strip 152 which the astronaut may grasp and pull to foreshorten the torso of the suit and relieve forward bending stresses on his body. The upper end of this assembly is provided with an upper lunar module supporting bracket including an eyelet, generally indicated at 154.

The space suit of the present invention is custom designed and fitted to each astronaut. In order to provide fine adjustment for the astronaut's limbs, portions of the arms and legs are joined by interlacing which may be adjusted to slightly shorten or lengthen the limb portions of the suit in accordance with the astronaut's preferences. The lacing in the arms is just above the wrist connector rings 123 and 125, as 156 at 156, and 158, respectively. Similar lacings are illustrated at 160 and 162 in the legs just above the boots 78 and 76. Formed in the right legs of the torso suit 114 of FIG. 5 and adapted to underlie the flap 50 of FIG. 1 is a urine transfer fitting 164 and a bio-medical injection patch 166. This patch comprises self-sealing rubber type material which may be punctured by a hypodermic needle but immediately reseals itself when the needle has been removed. The purpose of the patch is to permit the astronaut to inject himself with drugs or other medicines in the event he becomes sick or is in pain during an Apollo flight.

FIG. 6 is an enlarged view of the right leg of the torso limb suit illustrated in FIG. 5 with parts broken away to show portions of the thigh and knee convolutes. Specifically, the thigh convolute cover 130a which is sewn to the suit along its upper and lower edges, is broken away at 165 to show the thigh convolute 167. The convolute is molded and formed of a rubberized fabric to assume the natural shape of a convolute or substantially constant volume bellows. Passing beneath cable guide 138 and overlying the convolute is a metal wire or cable 168 secured at its lower end by eyelet 170 to a fabric reinforcement 172 sewn to the thigh cone 174. The other end of cable 168 is similarly attached above the bellows to the upper part of the leg by an eyelet indicated in dashed lines at 176. A similar cable (not shown) overlies the bellows on the inside leg surface, i.e., spaced approximately 180° around the leg from cable 168. These two thigh cables form an elongation restraint for the convolutes 166 so as to resist elongation of the convolutes when the suit is inflated. The substantially constant volume nature of the convolute permits the suit to be readily flexed in the area of the

thigh joint even when under substantial internal pressure.

Knee convolute cover 134 is similarly broken away at 178 to show a portion of the knee convolute 180. The convolute is similar to the thigh convolute and is molded from a rubberized fabric and similarly is restrained longitudinally by a pair of cables on opposite sides of the knee, one of which is illustrated in dashed lines at 182. The cable is joined at its upper end by an eyelet 184 to reinforcement 172 and at its lower end by an eyelet 187 to the lower leg cone 188. Near the bottom of the lower leg cone is provided a loop tape 190 and slide fastener 192 for joining the boot 161 of FIG. 5 to the leg of the torso limb suit. The urine transfer fitting 164 is shown as formed in the thigh cone 174 as is the bio-medical injection patch 166.

FIG. 7 is a perspective view of the comfort liner assembly forming the inner layer of the torso limb suit of FIG. 5. The comfort liner, generally indicated at 194 in FIG. 7, covers the entire body with the exception of the head, hands and feet. It includes a neck portion 196 with a snap flap 198 for the attachment of a communication lead for the microphones 68 and 70 of FIG. 2. Mounted on the shoulders of the liner are a pair of cushion pads 200 and 202 and similar pads 204 and 208 are provided on the upper arms. Sewn into the breast portion of the liner is a communications lead passthrough 210 and a bio-medical lead passthrough 212. A somewhat similar water connector passthrough 214 is sewn to the left breast of the liner. Fastener tapes are provided on the liner at 216, 218, and 220, and a waste valve lead passthrough 222 is sewn into the upper portion of the right leg. The fastener tapes, in conjunction with zippers 224 and 226 at the lower ends of the legs, are used to connect the liner to the interior of the pressure garment assembly and specifically to the interior of the torso limb suit of FIG. 5.

FIG. 8 shows the helmet half 228 of the helmet attaching ring assembly 54 of FIG. 2. FIG. 9 shows the suit half 120 of the helmet attaching ring assembly. The suit half 120 is formed of a metal housing 230 on which is mounted a vent channel 232, a resilient seal 234, and a locking ring 236. On the upper surface of the locking ring are a pair of index marks 238 and on the outside of the locking ring is a lock subassembly 240 and a lock stop 242. The helmet half 228 is similarly made of metal and is provided with a vent channel 244 adapted to cooperate with the channel 232 of the suit half 120 of the helmet attaching assembly. Similar index marks 246 are provided on the upper surface of the helmet half of the assembly. During assembly, the helmet half or ring 228 is telescopically received within the upper portion of the suit half or ring 120 and the vent channels are aligned by the index marks 238 and 246. The two rings are then locked together by the lock subassembly 240 in tight sealing engagement.

FIG. 10 is an enlarged perspective view of the pressure helmet assembly 52 of FIG. 2. The major portion of this assembly comprises a transparent shell of polycarbonate material attached at its lower end to the neck ring 228 of FIG. 8. Mounted in the rear of the helmet is a vent pad 248 having along its upper surfaces spacers 250 which space the upper end of the vent pad from the top of the helmet to provide gas channels 252 communicating with gas passageways 253 through the vent pad. Pressurized life supporting gas (oxygen) is transmitted upwardly through the passageways in the

vent pad and exhausts through the channels 252 over the head of the astronaut to impinge upon the front area of the helmet so as to prevent the helmet from fogging in front of the astronaut's face. Mounted near the front of the helmet is a feed port 256 normally closed off by feed port cover 258.

FIG 11 shows the space suit electrical harness by means of which the astronaut's physical condition is monitored and through which he communicates with other astronauts and with the space craft. The biomedical belt 96, which he wears around his waist and which is provided with bio-medical sensors, is provided with an upwardly extending noncrushable lead 260 which is electrically connected through connector 262 to an electrical harness 264. Approximately midway of the harness is an electrical jack 266 by means of which the astronaut is plugged into a suitable power supply, either in the space craft or in the lunar module previously described, by means of a multiwire cable passing through the electrical connector 66 of FIGS. 2 and 5. The upper end of the harness is electrically connected through connector 268 to the communications carrier 104 which fits over the astronaut's head. This harness includes a pair of earphones 270 and 272, as well as the microphones 68 and 70 previously described, which elements are embedded in or attached to the relatively soft fabric padding material of the communications carrier. Electrical connection to the harness from the microphones and earphones is by way of a noncrushable flexible lead 274.

FIG 12 is a perspective view of the rear of the outer covering or integrated thermal micro-meteoroid garment 112 of FIG 4 forming the outer component of the pressure garment assembly of the space suit. This garment is designed primarily for heat insulation to protect the astronaut from the extremes of heat and cold in space and on the lunar surface and also to protect the astronaut from micro-meteoroid bombardment. It consists of the integral boots 76 and 78 and covers the entire body with the exception of the hands and head. Extending from just below the neck is an entrance slide fastener flap 276 which covers the double slide fastener through which the space suit is entered. This flap is partly broken away at 278 to show the snap assembly 280 and loop tape 282 for closing it and lacing garment 112 to the torso limb suit assembly 114. A lunar module restraint strap 284 is attached over each hip and just above each knee is an assist strap 286. The outer cover garment 112 is of multilayer construction comprising a light colored reflective metallized outer shell and an inner liner separated by several spaced layers of heat insulating material.

FIG 13 is a perspective view of the pressure glove 72 of FIG 4. This glove is provided with individual fingers 294 and a separate thumb 296, all formed integral with a hand covering sheath molded from a rubberized fabric for good flexibility, i.e., Nylon dipped in a Neoprene compound. Preferably molded at the ends of the fingers and thumb are metal pieces (not shown) simulating finger nails to assist the astronaut in performing intricate tasks with the hands. Overlying the rubberized sheath and cemented to it is a fabric half glove 298 somewhat resembling in appearance a golf glove and formed of fabric to provide restraint for the rubberized fabric or bladder when the glove is inflated. Adjacent the wrist, the half glove 298 is provided with a fastener tape 300 and over the top portion with an adjusting belt 302.

Glove 72 is provided with a convolute enclosed by cover 303 and is joined to the space suit sleeve by a rotatable metal connector assembly as described below. Restraint cables in the glove cooperate with cover 303 to restrain the wrist convolute. The glove is molded to size from a cast of the astronaut's hand. Bladder projections 305 at the finger joints provide increased flexibility.

Adapted to be received over the pressure glove 72 of FIG. 13 is an extravehicular glove 38 shown in FIG 14. This glove is preferably made of good heat insulating material much in the manner of the integrated thermal micro-meteoroid garment of FIG. 12, and comprises an elongated cuff 304 extending upwardly over the forearm so as to cover the pressure relief valve 82 of FIG 2. This glove too is provided with separate fingers 306 and a separate thumb (not shown). Sewn to the top of the glove is a flap 308. The extravehicular glove 38 is provided with an adjustable strap 310 for tightening it over the upper portion of the astronaut's hand to provide restraint for the palm. Flap 308 is then turned down over the adjustable strap 310 and secured above the wrist by cooperating hook and pile fasteners 312 on the auxiliary flap 313 attached to the glove 38 by snap fasteners 314.

FIGS 15 and 16 are perspective views of the left and right lunar overshoes 42 and 40, respectively. The lunar overshoes are of similar construction and each includes a donning strap 316 forming a loop at the heel which may be grasped by the astronaut to draw the heel of the overshoe over the space suit boot. Each overshoe tongue 318 is provided with a snap fastener 320 cooperating with corresponding snaps 322 for connecting the front of the overshoe to the tongue. Finally, the overshoe is secured over the instep by a strap assembly 324 fastened by a latch 326. The lunar overshoe provides both thermal (insulation) and abrasion protection for the astronaut's foot on the lunar surface.

FIG. 17 is an enlarged view of the extravehicular visor assembly 20 of FIG 1. This visor comprises a collar 328 attachable to the neck of the space suit and a semispherical base 330 adapted to protect the astronaut's head both against physical damage and against intense heat and light from the sun. Base 330 is preferably a multilayer construction comprising an outer tough protective polycarbonate shell and an inner membrane separated by several layers of heat insulating material. The base is cut away in the front as indicated by the dashed line at 332 so that it may be slipped over the pressure helmet assembly 52 of FIG. 2. It is then attached to the neck of the space suit by means of a latching mechanism (not shown) and the flexible fabric collar 328.

Along the cut away front portion of the base is a visor, generally indicated at 334, comprising an outer rigid polycarbonate layer 336 forming a sun visor and a spaced inner rigid layer 338 of transparent polycarbonate forming a protective visor. The outer layer or sun visor is coated to provide light attenuation and to reduce heat gain within the helmet. It is provided with a tab 339 on each side so that it may be moved between full up and full down positions. The visor is pivoted on each side adjacent the astronaut's ears to the base 330. One of the support pivot assemblies 340 is illustrated in cross section in FIG 17A and comprises a pivot pin 342 secured to the base and biased by a hinge adjustment spring 344. This spring bears against a friction

plate 346 and the two visors are spaced by washers 348 and a central spacer 350. The upper and lower edges of the visor are closed off by light seals along its upper and lower edges as illustrated at 352 in FIG 17B and 354 in FIG 17C these figures respectively showing cross-sections of the circled areas A and B in FIG 17. Thus, when the astronaut closes the visor assembly 334, he is completely protected both against physical damage and against the intense and ultraviolet radiation from the sun existing in space and on the lunar surface. At the same time, each layer or shield 336 or 338 of the visor may be independently moved upwardly to any desired position and may be completely slid over the back of the visor assembly about pivot pins 342 when the protection is not needed and the astronaut wishes to see through the helmet more clearly.

FIG 18 is an enlarged view of the liquid cooling garment 98 of FIG 3. This garment is worn by the astronaut underneath the pressure garment assembly much in the manner of long underwear and is worn in conjunction with a pair of heavy socks 356 and 358 attached to it. The liquid cooling garment 98 may be worn by all the astronauts but is only required for extravehicular activity to provide liquid cooling when the astronaut is outside the space vehicle and exposed to the intense rays of the sun. The garment is provided at its front with a zipper 360 through which it is donned and with snap fasteners 361 for securing to it the biomedical belt 96 of FIG 3. A dosimeter pocket 362 is provided in the left leg of the garment and mounted on the waist is a water line 364 comprising inlet and outlet pipes terminating at their upper ends in a double or two-way connector 366. This connector is adapted to pass cooling water both into and out of the cooling garment by way of the connector 64 of FIG 2. The lower ends of the tubes 364 are connected to inlet and outlet manifolds respectively, generally indicated at 368, which in turn are coupled to Tygon tubing 370 which passes through the cooling garment and over substantially the astronaut's entire body.

FIG 19 is a diagrammatic view of the pressurization and ventilation system through the space suit of the present invention. Flow of pressurized life supporting gas, such as oxygen, is indicated by the arrows in FIG 19, the light arrows indicating inward flow and the darker arrows showing the return gas flow paths. While a preferred direction is illustrated, it is understood that the air flow, if desired, may be in the reverse direction. Oxygen may enter through either one of the gas inlet connectors 56 or 58 since these connectors are in fluid communication with each other by way of an intermediate plenum 372. A similar plenum 374 joins the gas outlet connectors 60 and 62 so that the outlet may be taken from either of these connectors. A redundant connector assembly is provided so that the astronaut may attach one set of connectors to the lunar module before exiting from the space vehicle without first having to disconnect the other set from the cabin supply. The double set of connectors is also provided so that the astronauts may be connected to each other in the event the supply to one of them for some reason fails.

Gas passes upwardly from one of the inlet connectors 56 or 58 by way of one of the noncrushable ducts 376 or 378 where it exists through vent channel 244 in the helmet ring into the vent pad 248 of the helmet shown in FIG 10 and downwardly over the astronaut's head onto the front surface of the helmet where it helps to

defog the helmet in front of the astronaut's face. The life supporting gas is, of course, also breathed by the astronaut.

Incoming gas is also supplied from one of the inlet connectors to the torso channels 380 and 382. These channels preferably are pervious to gas along their length so that the gas is distributed to the astronaut's torso over substantially the entire length of both the torso channels to which the gas is supplied. Gas from the helmet and from the torso under pressure passes over the astronaut's body and downwardly and outwardly of the limbs as indicated by the light arrows in the drawings. The gas is returned from the hands by way of arm channels 384 and 386 and to the respective outlet connectors 60 and 62. Similarly, gas is returned from the feet by way of leg channels 388 and 390 to the outlet connectors 60 and 62. The return channels 384, 386, 388 and 390 are vented adjacent the extremities so that the return gas may enter them and be conducted to the outlets. Foot pads 392 and 394 are also provided to help collect the returning gas and to ventilate the feet.

Thus, the life supporting gas (1) pressurizes the interior of the suit to a pressure of from 3 to 4 pounds per square inch, (2) provides a breathable gas to the astronaut, and (3) ventilates and helps cool the suit and removes moisture resulting from perspiration over the astronaut's entire body. Pressure gage 80 provides the astronaut with a visual indication of the pressure within the suit and a pressure relief valve 82 automatically opens when the pressure becomes too high to relieve the pressure within the suit.

FIGS 20 and 21 show the interconnecting locking rings for attaching a pressure glove, such as the glove 72 of FIG 4, to the suit. FIG 20 shows the suit half of the assembly, i.e., the suit ring at the wrist of the suit sleeve, and FIG 21 shows the glove half or the metal ring attached to the glove. The suit ring is the female half and is generally indicated at 396 in FIG 20. It comprises a locking ring 400 on a housing 402 to which is mounted a vent fitting 404. Locking ring 400 is provided with a pair of lock tabs 406 and 408, a lock button 410, and index marks 412 for aligning it with the glove ring of FIG 21.

The glove ring is the male half and is generally indicated at 414 in FIG 21. It consists of an outer race 416 on which is mounted a vent fitting 418 and an inner race 420. The rings of FIGS 20 and 21 are aligned by index marks and locked together in sealtight relationship to join the gloves to the sleeves of the space suit. The glove ring includes a sealed bearing with inner and outer races to permit 360° of glove rotation.

The torso limb suit 114 of FIG 5 forms the basic garment since it provides sealing over the greater part of the body to contain the life supporting gas and also incorporates restraint mechanisms so that the astronaut may move about and perform tasks. This torso limb suit assembly is a custom-sized unit which encompasses the body exclusive of the head and hands. The integrated thermal micro-meteoroid garment 112 is laced to the torso limb suit 114 and acts as a shield for the torso and limbs against the hazards of free space and lunar regions. The pressure helmet assembly is constructed of clear polycarbonate plastic and, when secured to the torso limb suit 114, remains in fixed position. The pressure glove is basically a conformal molded bladder having a quick disconnect coupling, restraining features

and is retained for intravehicle use only. The extravehicular glove provides thermal micro-meteoroid protection layers that are slipped over the basic pressure glove assembly. The lunar overshoe is similar in cross section to the extravehicular glove and is donned prior to egress. The slip-on helmet shield is a lightweight polycarbonate shell which fits over the pressure helmet assembly and provides scuff protection during tunnel transfer. The purge valve inserted into the helmet feed port is used to purge carbon dioxide from the helmet area during extravehicular operations. Gas connector caps are installed in the nonutilized gas connectors to prevent inadvertent depressurization as may be caused by the accidental opening of the water block within the connector. A suit donning cloth strap assembly is inserted into the slide tab of each rear entry slide fastener assembly, i.e., an inner pressure sealing fastener and an outer restraint slide fastener, at the back of the suit and these straps are used to facilitate actuation of the slide fasteners. The neck dam constructed of Neoprene fits around the neck and over the helmet attaching ring to prevent the entrance of water into the suit during water egress.

The torso limb suit 114 is an anthropomorphic pressure envelope which encloses the torso and limbs of the astronaut, exclusive of the head and hands. The torso section is custom sized to fit the individual while the limb sections are graduated in sizes and feature lace adjustment provisions to accommodate individual limb lengths. Convoluted joints near constant volume are located at the shoulders, elbows, hips, knees, and ankles (as well as at the glove wrists) to permit joint movements with a minimum of energy expenditure.

The suit is a gas retaining restraint assembly. It incorporates reinforced attachment supports for restraint cables which sustain axial limb loads during pressurized modes of operation. The front of the suit employs a block and tackle system having adequate mechanical advantage to permit the foreshortening of the torso during extended periods of sitting or bending. An arm assembly is secured to each torso scye opening. Axial loads across the shoulders are sustained by the shoulder restraint cable assembly.

A wrist disconnect assembly is secured to the lower arm extremity and consists of a mechanical self-sealing coupling designed to receive the pressure glove. A leg assembly is secured to the torso thigh opening. Axial loads at this joint are sustained by inner thigh crotch cables and outer thigh restraint cables. The thigh restraint cables are custom length and are designed to establish a proper crotch/limb angle which accommodates the wearer's need for comfort and mobility. The leg assembly ends at midcalf where it interfaces with the boot assembly. The boot assembly encloses the foot and is flexible enough to allow some ankle and foot movements.

The innermost layer of the torso limb suit is a removable liner assembly which is designed to promote comfort and to facilitate donning the suit. A mechanical self-sealing coupling is installed in the torso neck opening and is held in place by means of a compression band. The inlet and outlet gas connectors are attached to each side of the front torso. The dual or redundant connector installation permits an umbilical transfer between the ventilation systems of the space craft environmental control system, portable life supporting system, or test stand, without interrupting the flow of pres-

surization and ventilation gas through the suit. A ball-lock type quick disconnect multiple water connector assembly provides a dual passage through the suit for connecting the liquid cooling supply to the liquid cooling garment. When the liquid cooling garment is not connected, a plug is locked in place to prevent leakage of gas out of the suit during pressurized modes of operation. The suit electrical harness provides an electrical interface between the communications/bio-instrumentation components of the suit and the communications/bio-instrumentation umbilical of the space craft, portable life support system, or test stand. A transfer hose connected to the internal housing of the urine transfer connector interfaces with it for the transfer of urine to the waste management system of the space craft. The pressure gage provides for visual monitoring of the differential pressure. Mounted to the left wrist cone is a pressure relief valve which relieves suit pressures in excess of 5.5 psia.

The suit of the present invention is designed to afford pressurized protection for the astronaut during periods of extravehicular activity and in the space craft during pressurized modes of operation. The combination sealing and restraint structure of the suit accepts a standard operating pressure of 3.75 psig. The assembly is structurally tested at 6.0 psig and is periodically proof-tested at 8.0 psig. The suit is designed to withstand a burst pressure of not less than 10.0 psig. Also, the pressurized envelope will not permit leakage in excess of 180 scc per minute when pressurized to 3.75 psig under normal conditions. The gas flow into the helmet passes over the inside surface of the front of the helmet to facilitate helmet defogging and is then supplied to the oral-nasal area of the helmet for efficient respiration and dissipation of carbon dioxide from that area. As the flow of gas passes down through the neck opening area and over the body, the gas flow removes heat and transports evolved body gases, toxicants, and moisture out of the suit. The normal inlet gas flow temperature is expected to be 35°-85° F. During extravehicular modes of operation with the inlet gas connector diverter valves in the closed position, the specified pressure drop across the ventilation system is a nominal 2.273 inches of water at 6.0 cubic feet per minute flow rate of oxygen at 3.9 psia having an inlet gas temperature of 77° F. During intravehicular modes of operation with the inlet gas connector diverter valves in the open position, a nominal pressure drop of 4.7 inches of water will exist at 12.0 cubic feet per minute flow rate of oxygen at 3.5 psia with an inlet gas temperature of 50° F. The liquid cooling system is designed as the primary mode for removing body heat from within the suit during the performance of extravehicular mission tasks. During the circulation process, the heat within the suit is transferred to the liquid which returns through the outlet passage of the multiple water connector to the lunar module for cooling or chilling.

The space suit of the present invention is designed so that trained personnel may don all the equipment without assistance. The aid of a technician or fellow crewman, however, does facilitate donning and insures that the tasks are properly accomplished. After the undergarments are first placed on, a donning lanyard is attached to each of the slide fasteners, namely, the pressure sealing slide fastener and the restraint slide fastener which overlies it. The astronaut then assumes a sitting position and places the suit on his lap with the

rear entry area open With one hand the astronaut grasps the helmet attaching ring and with the other hand grasps the suit donning lanyard One foot is placed into the suit and manipulated until the foot is inserted in the boot This may be facilitated by grasping the loop at the rear of the boot. This procedure is then repeated for the other foot The suit is then pulled upward into proper position over the legs and well up into the crotch The hands are then inserted into the shoulder convolutes and the head is lowered and positioned into the neck ring while simultaneously slipping the hands fully into the arms and through the wrist connectors The astronaut then stands and permits the suit to settle over the torso and limbs One lanyard is then used to help close first the sealing slide fastener and then the restraint slide fastener which overlies it The various connections to the tubing, gloves and helmet then follow in the proper order In removing the suit, the procedure is reversed

It is apparent from the above that the present invention provides a novel space suit particularly designed to interface not only with cabin equipment but also portable equipment mounted on the astronaut's back so as to render the astronaut completely self-supporting and mobile in hostile space and lunar surface environments Important features of the suit include an inner comfort liner to be worn over the undergarments, an intermediate principal garment incorporating both pressure sealing and mobility restraints, and finally, an outer protective garment having heat insulating and a metallized fabric outer layer The suit covers substantially the entire body with the exception that it is provided with readily removable gloves and helmet so that the astronaut may be completely comfortable in the pressurized atmosphere of a space vehicle cabin

The invention may be embodied in other specific forms without departing from the spirit or essential characteristics thereof The present embodiment is therefore to be considered in all respects as illustrative and not restrictive, the scope of the invention being indicated by the appended claims rather than by the foregoing description, and all changes which come within the meaning and range of equivalency of the claims are therefore intended to be embraced therein

What is claimed and desired to be secured by United States Letters Patent is

1. A space suit for high altitude and space environments comprising a pressure garment having an inner sealing bladder and an outer restraint convering, a pair of like gas inlet connectors on said pressure garment connected together in substantially direct fluid communication with each other for selective use of either or simultaneous use of both inlet connectors for passing life supporting gas into said suit, a pair of like gas outlet connectors on said pressure garment connected together in substantially direct fluid communication with each other for selective use of either or simultaneous use of both outlet connectors for passing gas as exhaust out of said suit, an electrical connector on said pressure garment for connection of communications and bio-instrumentation to the interior of the pressure garment, and a self-sealing biomedical injection patch on said pressure garment

2. A space suit for astronauts comprising in combination a conformal pressure garment having an inner sealing bladder and an outer restraint layer, and outer thermal insulating garment over said pressure garment,

said pressure and thermal garments of said suit having torso and limb covering portions adapted to cover an astronaut's entire body except for hands and head, a transparent plastic helmet coupled to the neck of said garments, and a pair of pressure gloves rotatably coupled to the sleeves of said garments, said pressure garment including convoluted joints positioned in said torso and limb covering portions to provide ease of mobility when said pressure garment is worn, restraint cables secured to said pressure garment adjacent at least some of said convolutes to prevent elongation of said convolutes under internal gas pressure, a pair of like connected together gas inlet connectors on the chest of said pressure garment for passage into said suit of a life support gas, a pair of like connected together gas outlet connectors on the chest of said pressure garment for passage out of said suit of gas as exhaust, electrical and cooling liquid connectors on said pressure garment and a self-sealing biomedical injection patch in said pressure garment

3. A space suit according to claim 2 including a fecal containment system, a bio-medical belt, and a urine collection transfer assembly within said pressure garment

4. A space suit according to claim 2 including a liquid cooling garment having cooling liquid inlet and outlet manifolds, flexible cooling liquid tubing passing through said liquid cooling garment and connecting said inlet and outlet manifolds, and a connector on said pressure garment for passing liquid to said liquid cooling garment

5. A suit according to claim 2 wherein said gloves comprise a bladder and an outer restraint fingerless glove, said bladder having individual fingers and thumb

6. A suit according to claim 2 including boot portions and having removable thermal insulating gloves and overshoes received over the said pressure gloves and boot portions of said suit

7. A space suit according to claim 2 wherein each of said helmet, pressure gloves, neck and sleeves contain a metal ring, such rings respectively adapted for matingly coupling together said helmet with said neck and said pressure gloves with said sleeves

8. A space suit for astronauts comprising an undergarment adapted to cover the astronaut's entire body except for this head, an inner comfort liner, and outer thermal garment, and an intermediate pressure garment comprising an inner rubberized bladder and an outer fabric restraint layer, said comfort liner, pressure garment and thermal garment being integrally joined and adapted to conform to the astronaut's body, flexible joint portions in said suit adapted to fit over at least some of the locations of the astronaut's joints when the suit is worn, sleeve portions in said suit, a pair of removable pressure gloves secured to the said sleeve portions, a removable plastic helmet secured to the neck portion of said suit, a pair of inlet gas connectors operatively positioned in said suit for supplying gas under pressure into the interior of said suit, a pair of outlet connectors operatively positioned in said suit for removing said gas therefrom as exhaust, a flexible hose system secured to the interior of said pressure garment and operatively connected to said inlet gas connectors and to said outlet connectors for directing pressurized gas over the interior of said suit, a conduit system in said suit communicating with said hose system for pass-

17

ing some of said gas directly to the front of said helmet, a communications carrier within said helmet, an electrical connector on said suit, an electrical harness in said suit coupling said electrical connector to said communications carrier, convolutes at the joint portions, restraint cables secured to said pressure garment adjacent at least some of said convolutes to prevent elongation of said convolutes under internal pressure, and means on said suit for attaching to it a portable life support module

9. A space suit according to claim 8 including a block and tackle assembly secured to the front of said suit for

18

assisting the astronaut in bending.

10. A space suit according to claim 8 including a cable restraint assembly secured to said pressure garment and passing through the crotch of said suit so as to resist the expansion thereof

11. A space suit according to claim 8 wherein said thermal garment comprises several layers of insulation and a metallized fabric outer layer, said thermal garment including a removable chest cover for covering said inlet and outlet connectors provided in said pressure garment

* * * * *

15

20

25

30

35

40

45

50

55

60

65