



NATIONAL AERONAUTICS AND SPACE ADMINISTRATION

WASHINGTON, D.C. 20546

(NASA-Case-GSC-11046-1) COMPOSITE ANTENNA
FEED Patent (Philco-Ford Corp.) 7 p

N73-28013

CSSL 17B

REPLY TO
ATTN OF: GP

Unclas

00/07 10183

TO: KSI/Scientific & Technical Information Division
Attention: Miss Winnie M. MorganFROM: GP/Office of Assistant General Counsel for
Patent Matters

SUBJECT: Announcement of NASA-Owned U.S. Patents in STAR

In accordance with the procedures agreed upon by Code GP and Code KSI, the attached NASA-owned U.S. Patent is being forwarded for abstracting and announcement in NASA STAR.

The following information is provided:

U.S. Patent No. : 3,747,111
 Government or : Philco-Ford Corporation
 Corporate Employee : Palo Alto, CA
 Supplementary Corporate : _____
 Source (if applicable) : _____
 NASA Patent Case No. : GSC-11,046-1

NOTE - If this patent covers an invention made by a corporate employee of a NASA Contractor, the following is applicable:

Yes No

Pursuant to Section 305(a) of the National Aeronautics and Space Act, the name of the Administrator of NASA appears on the first page of the patent; however, the name of the actual inventor (author) appears at the heading of column No. 1 of the Specification, following the words ". . . with respect to an invention of . . ."

Elizabeth A. Carter

Elizabeth A. Carter

Enclosure

Copy of Patent cited above

[54] COMPOSITE ANTENNA FEED

3,474,452 10/1969 Bogner..... 343/726

[76] Inventors: James C. Fletcher, Administrator of the National Aeronautics and Space Administration with respect to an invention of; Vito Joseph Jakstys, Cupertino, Calif.

Primary Examiner—Rudolph V. Rolinec
Assistant Examiner—Saxfield Chatmon, Jr.
Attorney—R. F. Kempf, John R. Manning et al.

[22] Filed: Sept. 21, 1971

[57] ABSTRACT

[21] Appl. No.: 182,399

A composite antenna feed subsystem concentrated in a small area at the prime focus of the parabola of a satellite parabolic reflector accomodates a plurality of frequency bands. The arrays comprising the subsystem are mounted on the top cover of a communication module. A multimode horn is arranged at the center of the subsystem axis which functions at X- and C-band frequencies, and a cross-array consisting of individual elements form the S-band feed, with one arm of the S-band array containing an element mutually shared with the L-band array. Provision is also made for UHF frequencies, and a dipole arrangement for VHF frequencies is arranged around the S-band arms.

[52] U.S. Cl..... 343/725, 343/729, 343/797, 343/803, 343/893

[51] Int. Cl. H01q 21/00

[58] Field of Search..... 343/725, 726, 727, 343/728, 729, 730, 797, 893, 717, 798, 803

[56] References Cited
UNITED STATES PATENTS

3,482,248	12/1969	Jones, Jr.....	343/727
2,953,782	9/1960	Byatt.....	343/726 X
3,623,111	11/1971	Provencher.....	343/797
3,611,389	10/1971	Coors.....	343/730

13 Claims, 3 Drawing Figures

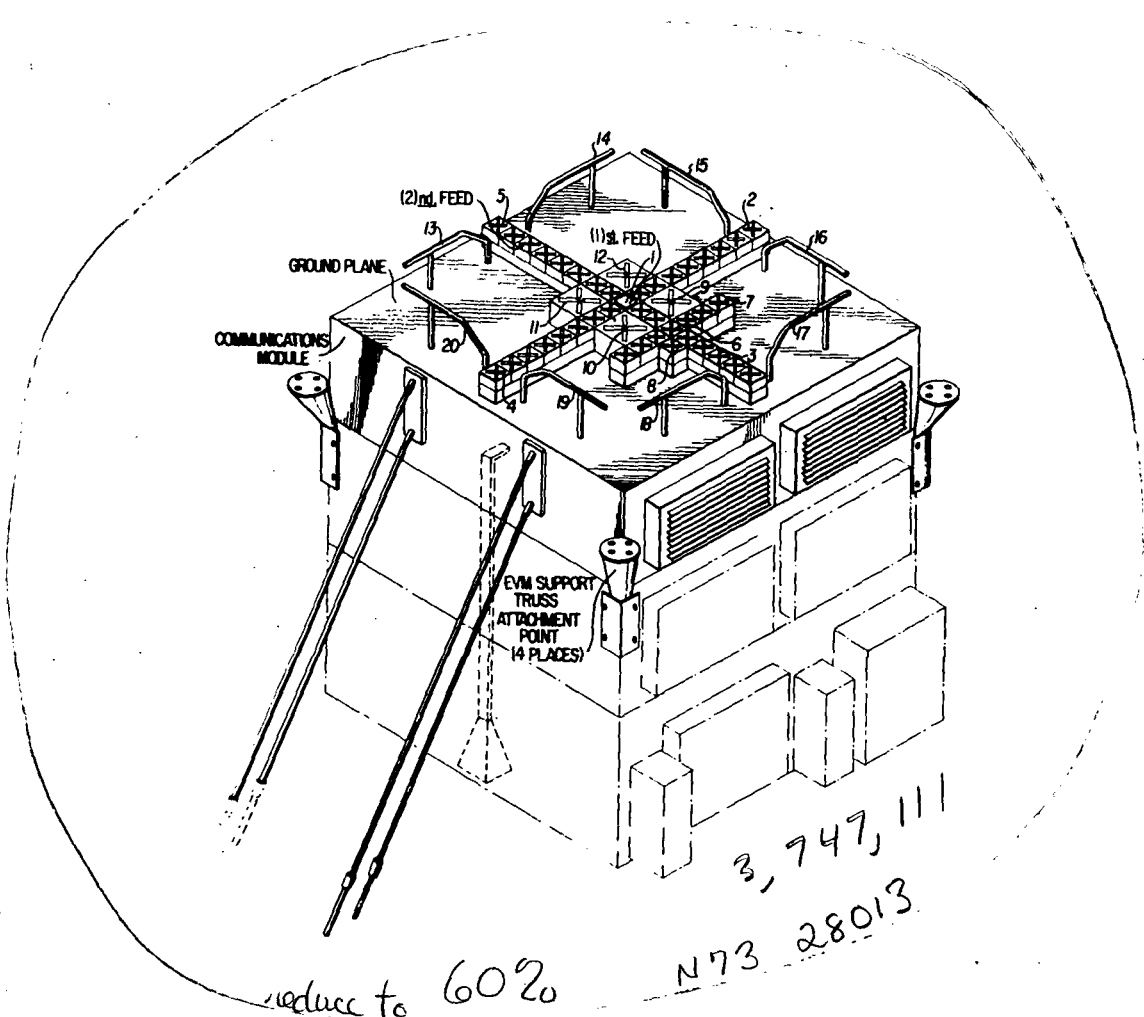

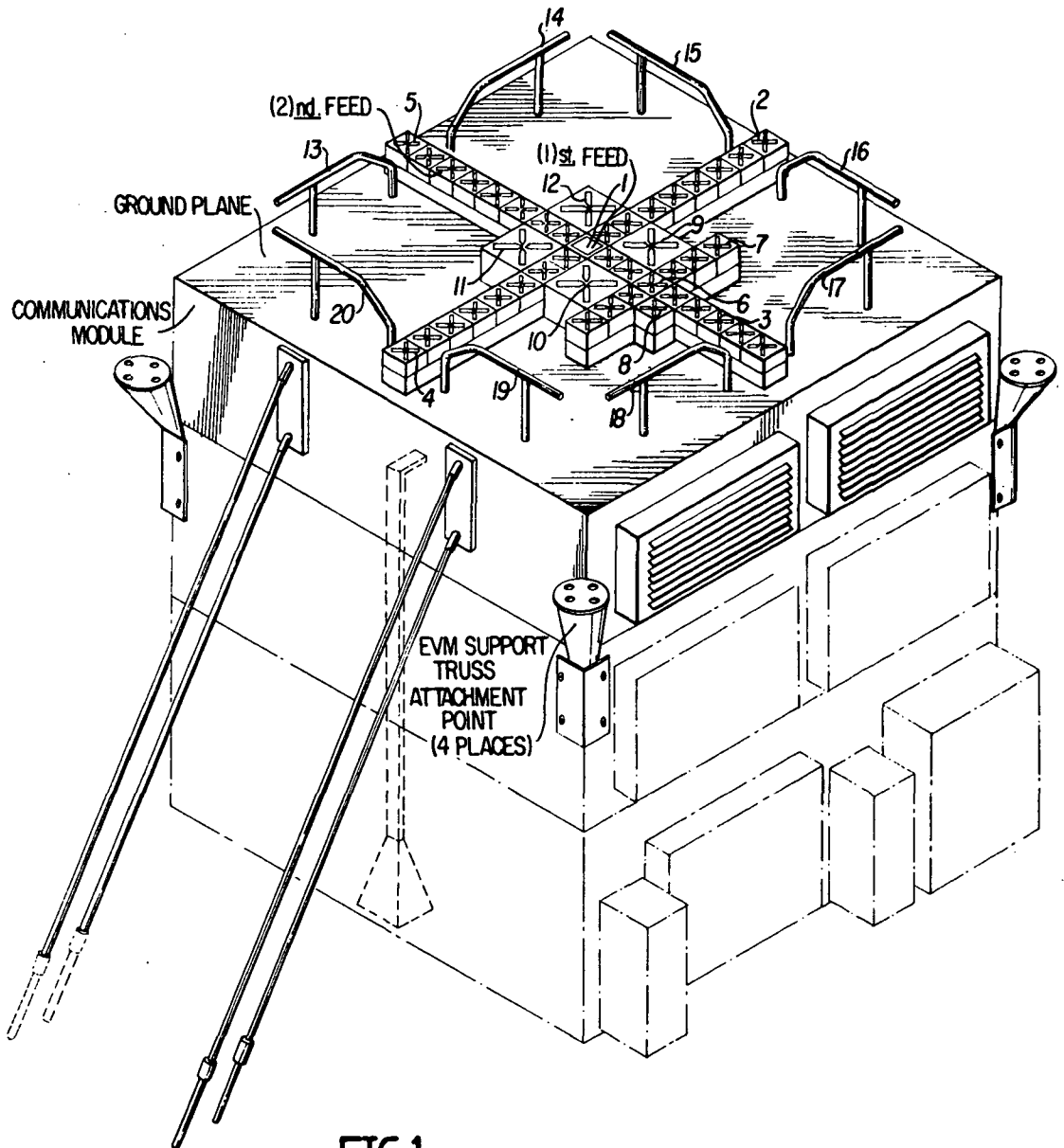

FIG.1

INVENTOR
VITO J. JAKSEYS

BY

Robert F. Kumpf
ATTORNEY

FIG. 3

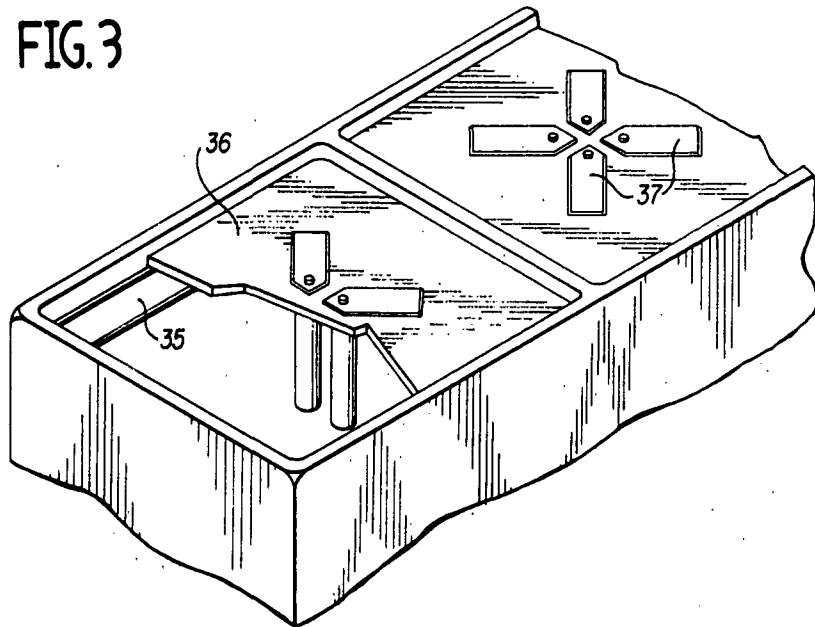
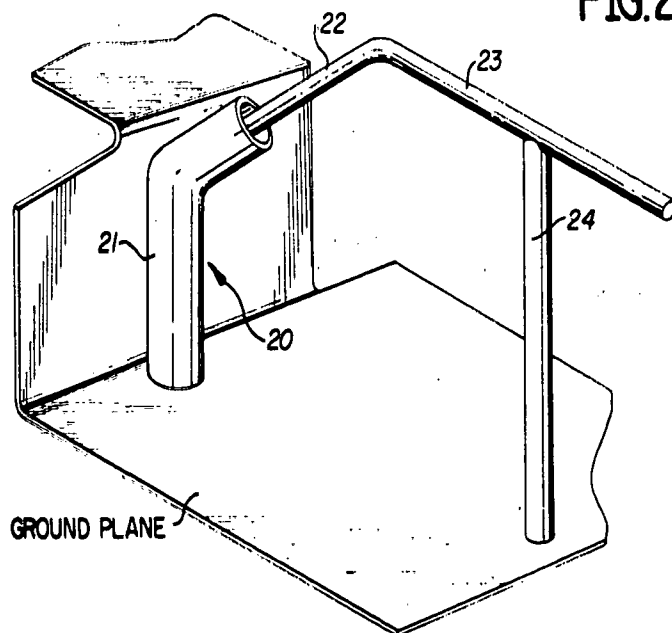

FIG. 2



COMPOSITE ANTENNA FEED**ORIGIN OF THE INVENTION**

The invention described herein was made in the performance of work under a NASA contract and is subject to the provisions of Section 305 of the National Aeronautics and Space Act of 1958, Public Law 85-568 (72 Stat. 435; 42 U.S.C. 2457).

BACKGROUND OF INVENTION**1. Field of Invention**

The invention relates to a prime focus antenna feed subsystem which serves as the interface between the multimode, multi-frequency subsystem of a transponder and a parabolic reflector of the antenna. It has particular utility in the field of antenna feeds at microwave communication wavelengths and for broadband RF field measurement systems, especially in conjunction with the NASA Applications Technology Satellite (ATS).

2. Prior Art

Multi-frequency feed subsystems having simultaneous transmit and receive functions are known in the prior art but those involved relate to multiple antennas of the same type such as multiple horns. Prior art feed subsystems also require rotating joints and mechanical devices for beam pointing.

SUMMARY OF THE INVENTION

The apparatus according to this invention provides several feeds designed to perform a diversity of functions. Thus, applicant provides an antenna feed subsystem capable of handling X-band, C-band, S-band, L-band, UHF and VHF frequencies.

For example, the S-band feed provides incremental beam scanning in two orthogonal planes and also simultaneous lobing (monopulse) operation. The L-band feed generates a fan-shaped beam by illuminating the entire reflector with uniform phase in one plane and only a portion of the reflector in the orthogonal plane. The feed elements are arranged in such a manner that minimum interaction results between the various feeds.

The feed is concentrated in a small area at the prime focus of the parabola of the parabolic reflector, and exhibits a high degree of radiation efficiency and minimal interaction between elements. The disclosed embodiment shows the composite feed system comprising an integral part of the top cover of the communications subsystem of the ATS F&G satellite, providing simplicity of assembly and test and the shortest possible RF cable lengths.

The composite feed subsystem comprises a multimode horn at the center of the subsystem axis which functions at X- and C-band frequencies. A plurality of arms consisting of individual elements form the S-band array and are centered about the multimode horn, with one arm of the S-band array containing an element mutually shared with the L-band array. Provision is also made for UHF and VHF frequencies, the VHF portion comprising a particular array also considered to be part of the invention.

The disclosed composite feed subsystem provides certain improvements over prior art multi-frequency arrays, such as:

1. Repeatability of electrical performance of like elements
2. Low cost fabrication

3. Minimum weight

4. High reliability necessary of spacecraft hardware

5. Broad frequency coverage

6. Medium density packaging

7. Use of simple radiating elements

The invention provides a broad frequency spectrum (UHF to X-band) of transmit/receive capability, while eliminating the rotating joints and mechanical devices commonly associated with prior art feed systems for beam pointing.

A BRIEF DESCRIPTION OF THE DRAWINGS

FIG. 1 is an isometric view of the communications module showing the composite feed system according to the invention, mounted on the cover thereof;

FIG. 2 is an isometric view showing the VHF feed element in greater detail;

FIG. 3 is an isometric view showing a typical arrangement of the crossed-dipole elements comprising the S- and L-band and UHF arrays of the composite feed system.

DETAILED DESCRIPTION OF THE DISCLOSURE

FIG. 1 is an isometric view of an Earth Viewing Module (EVM) showing the communications subsystem location. The composite feed system according to the invention is mounted on the ground plane of the communications module and comprises a prime focus antenna feed subsystem which serves as the interface between the multimode, multi-frequency transponder subsystem and the parabolic reflector in the ATS F&G satellite. The subsystem is capable of handling X-band, C-band, S-band, L-band, UHF and VHF frequencies concentrated in a small area at the prime focus of the parabola, with a high degree of radiation efficiency and minimal interaction between elements. The frequency ranges associated with the bands are:

Bands	Frequency Range
X	7.25 - 8.4 GHz
C	5.9 - 6.4 GHz
S	1.8 - 2.3 GHz
L	1.5 - 1.65 GHz
UHF	840 - 860 MHz
VHF	136 - 150 MHz

The X-band feed should generate an extremely narrow high-gain beam on the order of 0.3° to provide accurate antenna pointing and evaluation of reflector performance. The antenna pointing may be achieved in a linearly polarized monopulse system incorporated in the X-band feed.

The X-band feed comprises a center-mounted multimode horn 1 having thin metal walls arranged in a square horn configuration. The radiating aperture is of reduced cross-section to allow for closer spacing of the elements comprising the S-band array described hereafter. The reduced section is dielectric-loaded to support the necessary modes and to shape the primary radiation pattern.

The manner of feed excitation is not shown herein because it does not relate to the composite feed subsystem comprising the invention. This statement also applies to the excitation of other band and frequency feeds described hereafter. For illustrative purposes, however, the horn may be excited from a conventional four-port comparator consisting of waveguide hybrids through a four-port rectangular-to-square transition to generate the modes needed for monopulse operation

within the horn structure, the combination of the modes producing the sum and difference primary patterns.

The C-band feed makes use of a unique design wherein the X-band, multi-mode horn is shared at C-band frequencies. This provides coincidence between the C-band beam and the X-band sum channel beam. The C-band feed uses the high-gain of the reflector to receive low-level signals radiating from the earth in the 5,900–6,400 MHz frequency band. Two orthogonal, linear and circular polarizations are incorporated to allow analysis of potential Radio Frequency Interference (RFI) problems. At C-band frequencies, the feed may be excited through two shunt ports (not shown) located on opposite walls of the horn, and the horn is thus excited with two orthogonal modes.

Multimode horn 1, shared between the X- and C-bands, is shown in FIG. 1 as being centered at the center of the composite feed system. The S-band feed portion of the composite feed system comprises an array consisting of 32 cavity-backed crossed-dipole turnstile elements mounted in a cross-array coincident with the composite feed axis. With respect to FIG. 1, the S-band array comprises arms 2, 3, 4 and 5 arranged in orthogonal relationship in the same plane about the composite feed axis. The innermost elements of each arm may form a monopulse feed which can be used for single satellite tracking, although this is not a specific requirement of the composite feed system. The illustrated cross-array arrangement of the 32 turnstile elements comprising the S-band array provides the advantages of simplicity and cost reduction.

The S-band feed enables generation of beams to provide communications between low-altitude satellites including Apollo and Nimbus. Because of variations in the orbits of these satellites, the feed must be designed to generate incrementally scanned beams to permit simultaneous communications to the two satellites. In the S-band array, each of the 32 turnstile elements is connected to a diplexer and separate transmit and receive switching networks which enable a remote selection of feed elements to provide an independent feed-phase center for generating 32 secondary beams for the communications coverage in two orthogonal planes from the composite feed system axis, in an approximate range of $\pm 7.5^\circ$.

In order to locate all feed elements in the focal plane, the S-band array is elevated above the ground plane as shown in FIG. 1. The S-band diplexers and switching matrices (not shown) are located inside the communications module to provide a location having good thermal control for solid state components.

The third element 6 of arm 3 of the S-band array is shared with elements comprising the L-band array. FIG. 1 shows the L-band array as comprising a total of seven cavity-backed, crossed-dipole elements mounted in a line-array 7 to form the fan beam, and a separate cavity-backed, crossed-dipole element 8 to form the pencil beam. Line array 7 is parallel to arms 2 and 4 of the S-band array, and perpendicular to arms 3 and 5 thereof. The individual L-band elements are similar to individual S-band elements except that they are larger in size as shown in FIG. 1. In order to provide identity of elements comprising the L-band array, the third innermost element 6 of the S-band array is of the same size as the remaining elements comprising line array 7 and element 8 producing the pencil beam.

The L-band feed array illuminates the reflector with an elliptical primary pattern to produce a normal amplitude and constant phase characteristics in one plane, while in the orthogonal plane, only a portion of the reflector is illuminated with a constant phase energy. Asymmetric reflector illumination generates a fan-shaped secondary beam having an approximate half-power beamwidth defined by the wedge of 7.5° by 1.1° . Because of the displacement of the feed from the composite feed axis, the secondary beam is squinted approximately 3° off the antenna axis, and beam steering is accomplished by tilting the spacecraft. The pencil beam, produced by element 8, is symmetrical and as discussed above, is generated by using a separate single-cavity backed, crossed-dipole element to minimize switching losses.

The L-band feed illuminates the reflector in a manner which produces an elliptical beam designed to cover (one-half) of the hemisphere from synchronous altitude, i.e., the North Atlantic. This beam is required for the PLACE Experiment which will provide communications to aircraft traversing this high-density route. Because of the uncertainty in performance of the aircraft equipment, the high-gain pencil beam is provided as a backup.

The UHF feed comprises four cavity-backed crossed-dipole radiators 9, 10, 11 and 12 which form an array clustered around the center of the composite feed axis. The crossed-dipole radiators 9 through 12 are interposed between arms 2 through 5 of the S-band array. The elements are reduced in size to approximately 0.4 wavelength in order to allow for closer spacing between the phase centers, thus obtaining more favorable reflector illumination.

UHF feed generates a circularly polarized on-axis beam, which is coincident with the X-band monopulse axis. The on-axis beam eliminates asymmetry, which is always a problem in feed design. The UHF feed illuminates the reflector to provide a symmetrical beam on the order of approximately 3° . This finds particular utility in the experiment designed to transmit educational television signals to remote areas of Asia, including the country of India.

A VHF feed also comprises part of the composite feed system to provide capability of monopulse acquisition of the ground station and a high-gain link for certain telemetry and command data. As shown in FIG. 1, it comprises eight quarter-wavelength ($\lambda/4$) loops or stubs 13 through 20 arranged to comprise four dipoles mounted near the outermost ends of adjacent arms of the S-band array. Thus, loops 19 and 20 comprise a dipole element arranged near the outermost end of arm 4, for example.

FIG. 2 shows in greater detail, the elements comprising the VHF feed. Each radiating element (20, for example) extends perpendicularly upward from the ground plane in a plane parallel to the wall of the adjacent S-band array for length 21, which is substantially equal to the height of the top edge of the wall above the ground plane, as shown in FIGS. 1 and 2. The radiating element 20 then angles out and up from the wall for length 22, and then extends out from the wall in a perpendicular direction thereto, and in a plane parallel to the ground plane for length 23. Length 21 and a portion of length 22 of the radiating element, are surrounded by a coaxial cable to prevent interference with the adjacent S-band array arm. Dielectric support

24 functions to support the outer portion of length 23 from the ground plane. Radiating element 20, in association with radiating element 19, thus forms a dipole element. The remaining pairs of radiating elements are structurally and functionally similar to radiating elements 19 and 20 and, for this reason, are not described herein in detail.

A typical arrangement of the crossed-dipole elements comprising the S- and L-band and UHF arrays is shown in FIG. 3 of the drawings. The S- and L-band arrays may comprise an integral unit having walls and separating partitions defining plurality of cavities housing the crossed-dipole elements. Lip 35 extends within and around the cavity to support fiberglass board 36 which is securely attached to the lips. The radiating arms 37 are mounted in orthogonal relationship to each other to form the crossed-dipole elements. It is intended that FIG. 3 serve only as one illustrative embodiment of a conventional crossed-dipole design and it is to be understood that other equivalent structures may be substituted therefor.

The composite feed has a fixed relationship with the prime (longitudinal) axis (axis perpendicular to the EVM cover and also coincident with the antenna system axis). Adjustment capability is provided at the junction of the EVM support truss and parabolic reflector hub to properly relate the feeds and the reflector. Further, to properly locate the feed phase center at the focal plane of the reflector, axial adjustment is provided at the junction of each truss leg and the reflector hub. Adjustment is also provided to accurately align the focal plane and focal axis of the reflector with respect to the feeds. The adjustment elements are not shown because they are conventional in the art and are discussed herein merely to indicate that such adjustments may be provided.

The composite feed system provides for the elimination of all rotating joints and mechanical devices in the feed system for beam pointing. Specific applications of a composite antenna may not require one or more of the bands or frequencies disclosed herein, and the corresponding elements may therefore be eliminated, thus allowing further optimization of the remaining feeds without departing from the scope of the invention.

I claim:

1. A composite antenna feed subsystem operative at a plurality of frequency bands comprising:
 - a first feed shared by first and second frequency bands,
 - a second feed for a third frequency band having an array of four arms arranged in orthogonal turnstile relationship centered around the center of the first feed,
 - a third feed for a fourth frequency band having a plurality of radiator elements arranged in a square form array centered around the center of the first feed, individual elements of the third feed being interposed between adjacent arms of the second feed,
 - a fourth feed for a fifth frequency band having a plurality of elements arranged in a line array and including an element mutually shared with an arm of the second feed, and
 - a fifth feed for a sixth frequency band having an array of elements arranged near the ends of the arms of the second feed located outermost from the center of the first feed, the first, second, third, fourth and

fifth feeds being mounted to a common ground plane structure.

2. The composite antenna feed subsystem recited in claim 1 wherein the first feed comprises a multimode horn centered at the prime axis of the subsystem.

3. The composite antenna feed subsystem recited in claim 2 wherein the second feed comprises a plurality of crossed-dipole elements in each arm of the array.

4. The composite antenna feed subsystem recited in claim 3 wherein the fourth feed comprises a plurality of crossed-dipole elements arranged in a line array parallel to two opposite arms of the second feed.

5. The composite antenna feed subsystem recited in claim 4 wherein the fourth feed further comprises a single crossed-dipole element mounted adjoining the line array.

6. The composite antenna feed subsystem recited in claim 5 wherein the fifth feed array of elements comprises dipoles arranged near the outermost end of each of the arms of the second feed.

7. The composite antenna feed subsystem recited in claim 1 for use in an EVM satellite as an interface between the transponder and parabolic reflector, wherein the common ground plane structure is the top cover of the EVM satellite.

8. A composite feed subsystem mounted on the top cover of an EVM of a satellite for use as an interface between a transponder and parabolic reflector comprising:

a plurality of feed arrays for different frequency bands mounted about the prime axis of the EVM top cover,

a VHF feed array having a dipole element mounted at substantially the center and near the edge of each side of the EVM top cover;

wherein one of the plurality of feed arrays comprises four arms arranged in orthogonal turnstile relationship about the prime axis, each arm having an outermost end located substantially at the center and near the edge of a different side of a substantially rectangular EVM top cover, the VHF feed having first and second coacting radiating elements mounted near said outermost ends of each of the four arms to form four dipoles.

9. The composite antenna feed subsystem recited in claim 9 wherein each of the arms of said one of the plurality of feed arrays comprises a plurality of crossed-dipole elements.

10. The composite antenna feed subsystem recited in claim 9 wherein at least a portion of the first and second radiating elements located nearest the arms of said one of the plurality of feed arrays is surrounded by a coaxial cable.

11. In an antenna system, a first VHF integral radiating element comprising:

a first length extending in a perpendicular direction relative to a ground plane of reference,

a second length extending from the end of the first length in a direction which forms an obtuse angle with the first length,

a third length extending from the end of the second length in a direction substantially perpendicular to the first length,

a dielectric support mounted between a portion of the third length nearest its free end and the ground plane,

7

the first, second and third lengths and the dielectric support defining a plane substantially perpendicular to the ground plane.

12. The antenna system as recited in claim 11 wherein the ground plane of reference comprises the top cover of an EVM satellite, and further comprising: a second VHF integral radiating element spaced from and arranged in mirror image relationship to the first radiating element, operative to function there-

8

with as a dipole.

13. The antenna system as recited in claim 12 further comprising a feed array corresponding to another frequency band interposed between the spaced first and second radiating elements, and coaxial cables surrounding portions of the first and second radiating elements to shield the latter from the interposed feed array.

* * * * *

10

15

20

25

30

35

40

45

50

55

60

65

