



NATIONAL AERONAUTICS AND SPACE ADMINISTRATION
WASHINGTON, D.C. 20546

AUG 7 1973

REPLY TO
ATTN OF: GP

TO: KSI/Scientific & Technical Information Division
Attention: Miss Winnie M. Morgan

FROM: GP/Office of Assistant General Counsel for
Patent Matters

SUBJECT: Announcement of NASA-Owned U.S. Patents in STAR

In accordance with the procedures agreed upon by Code GP and Code KSI, the attached NASA-owned U.S. Patent is being forwarded for abstracting and announcement in NASA STAR.

The following information is provided:

U.S. Patent No. : 3,744,247

Government or Corporate Employee : U.S. Government

Supplementary Corporate Source (if applicable) : _____

NASA Patent Case No. : XLE-10453-2

NOTE - If this patent covers an invention made by a corporate employee of a NASA Contractor, the following is applicable:

Yes No

Pursuant to Section 305(a) of the National Aeronautics and Space Act, the name of the Administrator of NASA appears on the first page of the patent; however, the name of the actual inventor (author) appears at the heading of column No. 1 of the Specification, following the words ". . . with respect to an invention of . . ."

Elizabeth A. Carter

Elizabeth A. Carter
Enclosure
Copy of Patent cited above

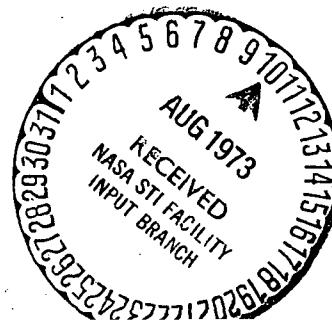

N73-27699
Unclas 10026
00/28
(NASA-Case-XLE-10453-2) SINGLE GRID Patent CSCL 21C
ACCELERATOR FOR AN ION THRUSTOR
(NASA) 4 P

[54] **SINGLE GRID ACCELERATOR FOR AN ION THRUSTOR**

[75] Inventors: **Paul M. Margosian**, Roslindale, Mass.; **Shigeo Nakanishi**, Berea, Ohio

[73] Assignee: **The United States of America as represented by the Administrator of the National Aeronautics and Space Administration**, Washington, D.C.

[22] Filed: **Sept. 14, 1971**

[21] Appl. No.: **180,473**

Related U.S. Application Data

[63] Continuation of Ser. No. 758,540, Sept. 9, 1968, abandoned.

[52] U.S. Cl. **60/202, 313/63, 313/217, 313/218, 313/230, 313/355**

[51] Int. Cl. **F03h 5/00**

[58] Field of Search **313/63, 207, 107, 313/230, 355, 218, 217; 60/202**

[56]

References Cited

UNITED STATES PATENTS

3,371,489	3/1968	Eckhardt	313/63 X
2,913,617	11/1959	Tucker.....	313/355 X
3,021,446	2/1962	Ekkers et al.....	313/218 X
3,345,820	10/1967	Dryden	313/63 X
3,500,122	3/1970	Sohl	313/63 X
2,068,287	1/1937	Gabor	313/207 X
2,094,450	9/1937	Geffcken et al.....	313/207 X
3,250,942	5/1966	Yoshida et al.....	313/107 X
3,297,902	1/1967	Beggs.....	313/355 X

Primary Examiner—Palmer C. Demeo
Attorney—N. T. Musial, Gene E. Shook et al.

[57]

ABSTRACT

A single grid accelerator system for an ion thruster. A layer of dielectric material is interposed between this metal grid and the chamber containing an ionized propellant for protecting the grid against sputtering erosion.

3 Claims, 3 Drawing Figures

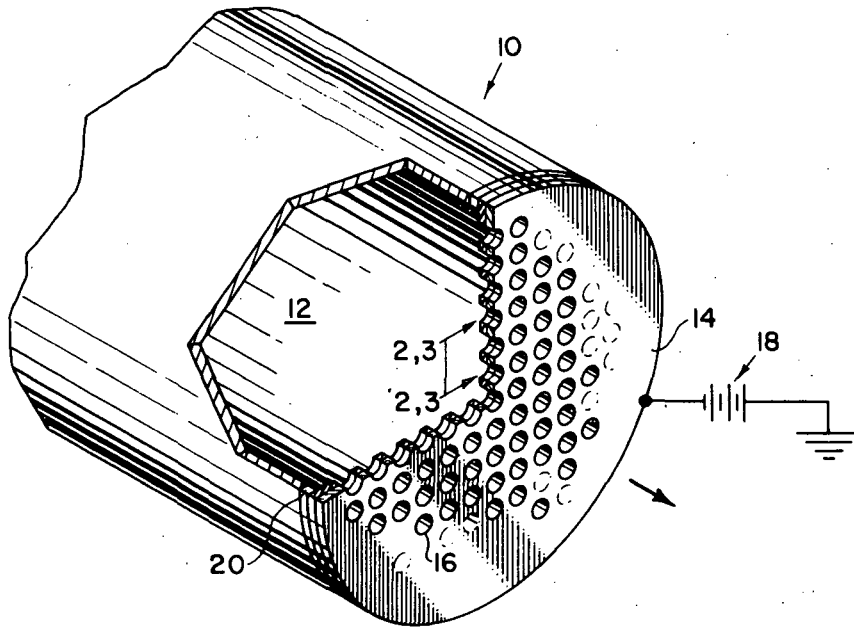

602

Patent 3,744,247
 NASA CASE-XLE-10453-2
 N73-27699 - STAR 18

PATENTED JUL 10 1973

3,744,247

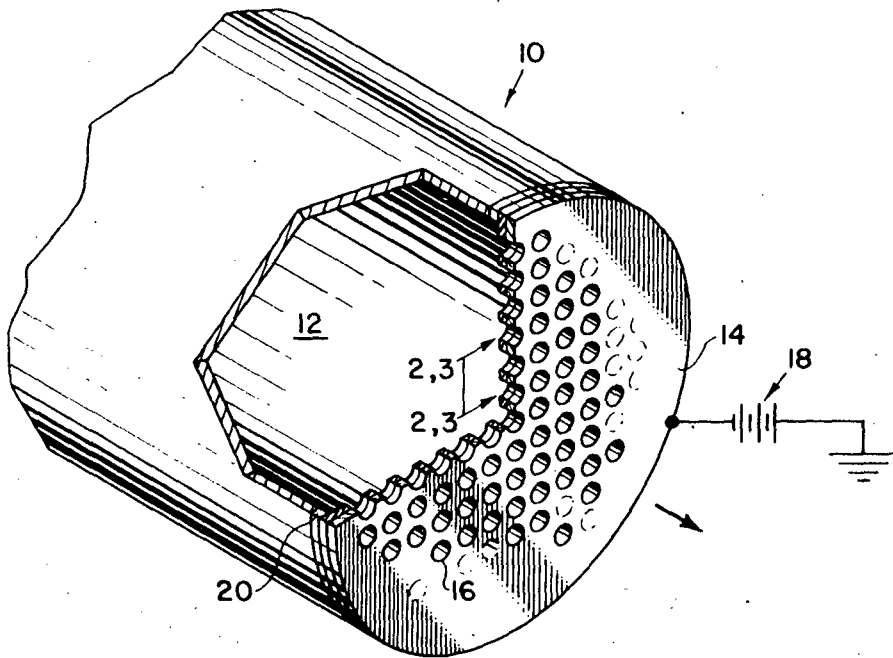

FIG. 1

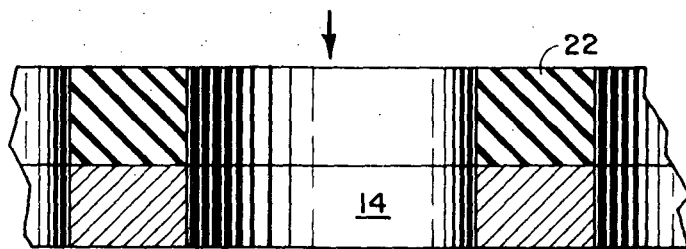

FIG. 2
16

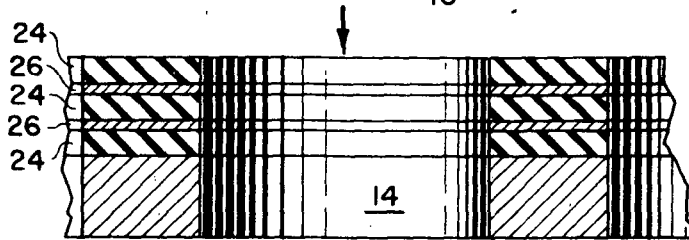

FIG. 3
16

INVENTORS
PAUL M. MARGOSIAN
SHIGEO NAKANISHI

BY

Gene E. Shook
Gene E. Shook

ATTORNEYS

SINGLE GRID ACCELERATOR FOR AN ION THRUSTOR

This is a continuation of application Ser. No. 758,540 filed Sept. 9, 1968, and now abandoned.

STATEMENT OF GOVERNMENT OWNERSHIP

The invention described herein was made by employees of the United States Government and may be manufactured and used by or for the Government for governmental purposes without the payment of any royalties thereon or therefor.

BACKGROUND OF THE INVENTION

This invention is concerned with an improved ion extractor component for an ion thruster. The invention is particularly directed to a single grid accelerator system for an electron bombardment type ion thruster.

Accelerator grid systems used in electron-bombardment thrusters have depended on a screen grid and an accelerator grid as two main components. Both are made of stainless steel or molybdenum and are mounted at close spacing relative to each other. The grids are maintained at a potential difference of several thousand volts with respect to each other. This voltage applied over the close spacing provides an electric field required for the extraction of ions from the ionization chamber thereby providing thrust. The screen grid is operated at a positive potential and the accelerator at a negative potential. This "accel-decel" mode of operation insures maximum ion extraction while preventing back streaming of neutralizing electrons into the thruster.

One type of grid system employs a parallel wire arrangement. Such a system is shown in U.S. Pat. No. 3,156,090. A pair of perforated plates having aligned holes has also been utilized. The overall weight of these double grid systems as well as the hardware required for proper mounting is objectionable. The required uniform gap of close spacing between the grids further creates fabrication problems.

SUMMARY OF THE INVENTION

These problems have been solved by the single grid accelerator system constructed in accordance with the present invention. A dielectric material is interposed between the grid and the thruster ionization chamber. A metal grid has its upstream surface covered with dielectric material, or a dielectric grid may have its downstream surface covered with a metal.

It is, therefore, an object of the present invention to provide a single grid accelerator system for an electron bombardment ion thruster.

Another object of the invention is to provide an improved accelerator grid for an ion thruster which is readily fabricated.

A still further object of the invention is to provide an electron bombardment ion thruster which accomplishes the ion extraction function in an improved manner.

These and other objects of the invention will be apparent from the specification which follows and from the drawing wherein like numerals are used throughout to identify like parts.

DESCRIPTION OF THE DRAWING

FIG. 1 is an isometric view having parts broken away along an axial quarter section of an electron bombard-

ment ion thruster showing an accelerator system constructed in accordance with the present invention,

FIG. 2 is an enlarged sectional view taken along the line 2—2 in FIG. 1, and

FIG. 3 is an enlarged sectional view similar to FIG. 2 but showing an alternate embodiment of the invention.

DESCRIPTION OF THE PREFERRED EMBODIMENT

An electron bombardment ion thruster of the type described in U.S. Pat. No. 3,156,090 utilizes mercury as a propellant. Mercury vapor is supplied to an ionization chamber through a distributor plate, and atoms of mercury are bombarded by electrons emitted from a cathode. An axial magnetic field is supplied to increase the path length traveled by electrons going from the cathode toward an anode thereby increasing the ionization by electron bombardment.

Such an electron bombardment ion thruster utilizes both a screen grid and an accelerator grid in its ion extraction portion. The screen grid serves to contain the discharge plasma forming the necessary ion optics to prevent direct impingement of accelerated ions onto the accelerator grid. Ions in the near vicinity of the screen grid have a high probability of being accelerated to openings in the grids because of the high electric fields present. Thrust is produced as these ions accelerate through the grid system.

Referring now to FIG. 1 there is shown an electron bombardment ion thruster 10 of the aforementioned type. The ion thruster 10 has an ionization chamber 12 for containing mercury propellant that has been ionized by electron bombardment in the manner previously described.

The ion thruster further includes an accelerator system for accelerating propellant ions in the direction of the arrows in FIGS. 1 and 2. This accelerator system utilizes a single grid 14 in the form of a perforated plate of an electrically conducting material. The accelerated propellant ions pass through holes 16 in this plate.

The grid 14 is connected to a source of electrical power, such as a battery 18, as shown in FIG. 1. The electrical power source 18 impresses a potential on the grid 14 and is highly negative relative to the ionization chamber 12.

An insulator 20 having an annular configuration extends about the periphery of the ionization chamber 12. The insulator 20 serves to electrically isolate the single grid from the metal housing forming the ionization chamber 12.

An important feature of the invention is that the electrically conducting grid 14 has the surface that faces the ionization chamber 12 protected from sputtering erosion. This is accomplished by positioning a layer of insulating material 22 between the chamber 12 and the grid 14 as shown in FIGS. 1 and 2.

The grid 14 is electrically conductive to establish the proper electrostatic field for accelerating the ions in the chamber 12 in the direction of the arrow. The grid 14 may be of a perforated metal plate having the upstream surface covered with dielectric material 22 as shown in FIG. 2. A molybdenum grid 14 having a coating of aluminum oxide flame sprayed thereon to form the dielectric coating 22 may be utilized.

In general, deposited dielectric materials exhibit some degree of porosity which could be significant in

long duration applications. The alternate embodiment shown in FIG. 3 is preferred where long operating life is of primary importance.

This embodiment utilizes a grid 14 in the form of a perforated metal plate which is identical with the grid shown in FIGS. 1 and 2. Instead of utilizing a single covering of dielectric material as shown in FIG. 2, the alternate embodiment utilizes layers of dielectric material 24 that are separated by layers of metal 26. The metal layers 26 are nonporous.

Vapor deposition of the metal 26 is preferred because the thickness of this layer can be controlled. Such a deposition process enables larger overall potential differences between the positive plasma and the negative base metal grid to be maintained.

It is further contemplated that a perforated plate of dielectric material 22 could be used at the start of fabrication. The downstream surface of this dielectric plate would be covered with a metal to form the grid 14.

The single grid 14 mounts in the same location as the previous grid systems and serves the same purpose. However, this accelerator system accomplishes the ion extraction in an improved manner. The single grid 14 is maintained at a negative potential by the electrical power source 18. The dielectric layer 22 which is exposed to the plasma in the ion chamber 12 assumes a positive potential nearly equal in value to that of the plasma potential. The electric field necessary for ion extraction is established with a single component accel-decel grid system rather than the conventional two component system. Potential differences up to the break down limits of the dielectric material in the layer 22 are possible.

While several preferred embodiments of the invention have been described, it will be appreciated that various modifications may be made to the disclosed structure without departing from the spirit of the invention or the scope of the subjoined claims. For example, the size of the grid as well as the geometry of the perforations may be varied. It is further contemplated that the geometry of the dielectric layer may be changed to meet the special requirements.

We claim:

1. An electron bombardment ion thruster comprising a source of ions comprising
 - a cylindrical housing forming a chamber, ionized mercury forming a plasma having a positive potential in said chamber,
 - an aluminum oxide plate having a plurality of apertures therein mounted on said housing thereby covering one end of said chamber, said aluminum oxide plate having a first surface facing towards said chamber and a second surface facing away from said chamber, said apertures extending between said first and second surfaces, said aluminum oxide plate having a positive potential substantially equal to that of said plasma whereby said plasma covers said first surface and said apertures,
 - an annular insulator extending about the periphery of said chamber in contact with said housing and said first surface of said plate, and
 - an accelerator system comprising
 - a layer of molybdenum covering said second surface of said aluminum oxide plate, and
 - means for applying a potential to said molybdenum that is highly negative to said plasma whereby ions from said plasma covering said apertures in said aluminum oxide plate are accelerated through said apertures to produce thrust.
2. An electron bombardment ion thruster having an accelerator system as claimed in claim 1 including a second aluminum oxide plate in contact with a surface of said molybdenum layer opposite said first named aluminum oxide plate, and
 - a second molybdenum layer covering said second aluminum oxide plate.
3. An electron bombardment ion thruster as claimed in claim 2 having a third aluminum oxide plate in contact with the surface of said second molybdenum layer opposite said second aluminum oxide plate, and
 - a third molybdenum layer in contact with said third aluminum oxide plate.

* * * * *

45

50

55

60

65