



NATIONAL AERONAUTICS AND SPACE ADMINISTRATION
WASHINGTON, D.C. 20546

Lewis

N73-27062

REPLY TO
ATTN OF:

(NASA-Case-LEW-11669-1) OPTHALMIC METHOD
AND APPARATUS Patent (NASA) 4 P CSCL 06L

00/05 Unclas
06483

KSI/Scientific & Technical Information Division
Attention: Miss Winnie M. Morgan

FROM: GP/Office of Assistant General Counsel for
Patent Matters

SUBJECT: Announcement of NASA-Owned U.S. Patents in STAR

In accordance with the procedures agreed upon by Code GP
and Code KSI, the attached NASA-owned U.S. Patent is being
forwarded for abstracting and announcement in NASA STAR.

The following information is provided:

U.S. Patent No. : 3,736,938
Government or
Corporate Employee : U.S. Government
Supplementary Corporate
Source (if applicable) : _____
NASA Patent Case No. : LEW-11669-1

NOTE - If this patent covers an invention made by a corporate
employee of a NASA Contractor, the following is applicable:

Yes No

Pursuant to Section 305(a) of the National Aeronautics and
Space Act, the name of the Administrator of NASA appears on
the first page of the patent; however, the name of the actual
inventor (author) appears at the heading of column No. 1 of
the Specification, following the words "... with respect to
an invention of . . ."

Elizabeth A. Carter

Elizabeth A. Carter
Enclosure
Copy of Patent cited above

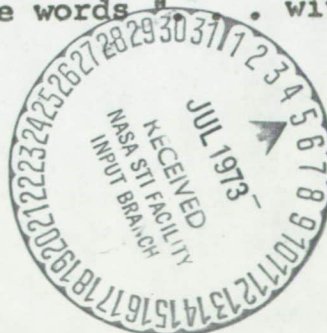

N 73 27 002
3020

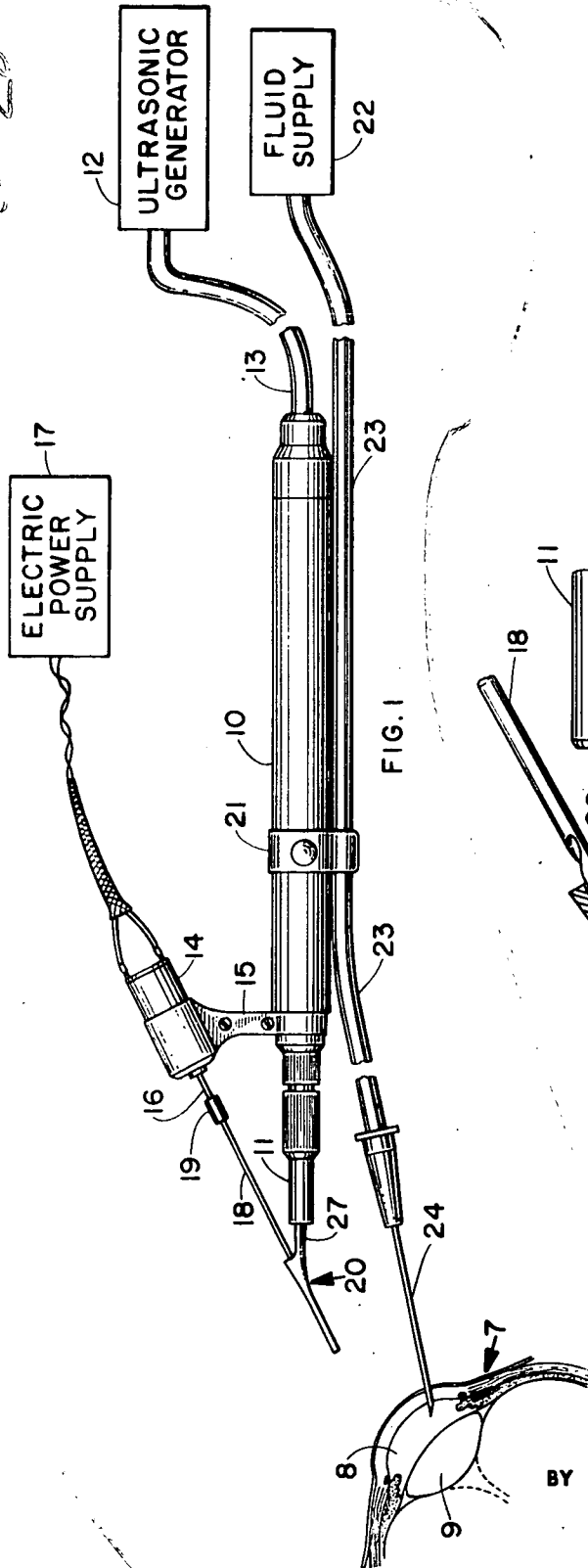

FIG. 1

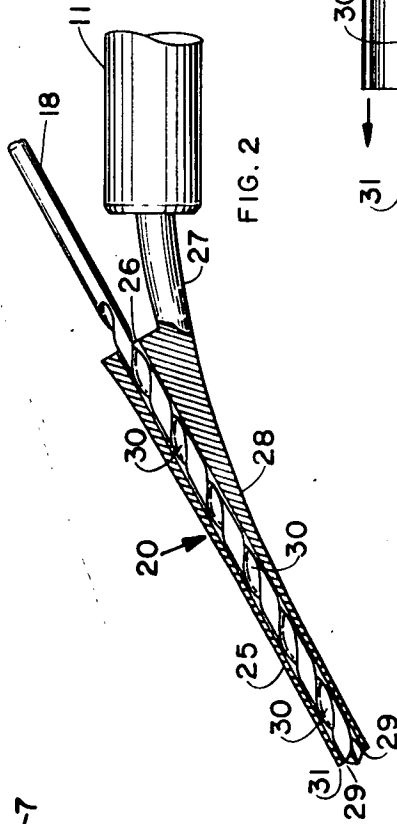

FIG. 2

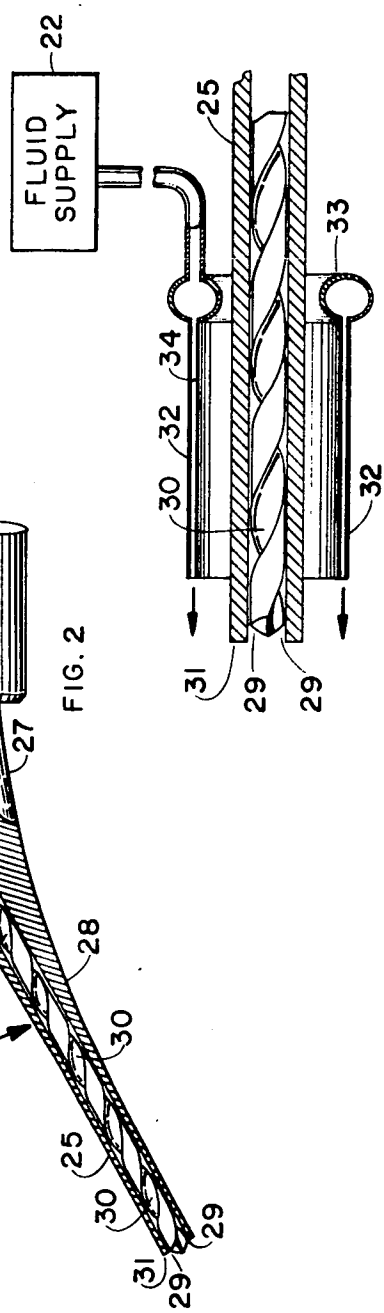

FIG. 3

INVENTORS
 JOHN C. EVVARD
 WILLIAM J. MCGANNON
 DONALD J. VARGO

Norman T. Maxial
James R. Masten

ATTORNEYS

- [54] **OPHTHALMIC METHOD AND APPARATUS**
- [75] Inventors: John C. Evvard, Strongsville; William J. McGannon, Lakewood; Donald J. Vargo, Seven Hills, all of Ohio
- [73] Assignee: The United States of America as represented by the Administrator of the National Aeronautics and Space Administration, Washington, D.C.
- [22] Filed: Nov. 15, 1971
- [21] Appl. No.: 198,885
- [52] U.S. Cl. 128/305, 128/2, 128/24 A, 32/28, 32/58
- [51] Int. Cl. A61b 17/32, A61b 17/00
- [58] Field of Search 128/24, 305; 32/28, 32/58

3,528,410	9/1970	Banko	128/24 A
3,589,363	6/1971	Banko	128/24 A
3,614,953	10/1971	Moss	128/305
3,693,613	9/1972	Kelman	128/24 A

Primary Examiner—Aldrich F. Medbery
 Attorney—N. T. Musial, J. A. Mackin and John R. Manning

[57] **ABSTRACT**

A method and apparatus for removing material and components such as the lens from an eye is described. High speed rotary cutting members at one end of a rod macerate the lens while an annular tubing disposed around the cutting members vibrates ultrasonically to coact with the cutting members in macerating the lens. At the same time, a liquid is supplied to the chamber behind the cornea of the eye. Spiral grooves extending along the rotating rod from the cutting members evacuate the liquid and the macerated material from the eye. An alternate embodiment of the apparatus includes a tube through which liquid is supplied to the operative site of the ultrasonically vibrating tube and the cutting members in the area of the lens.

- [56] **References Cited**
- UNITED STATES PATENTS**
- 3,526,219 9/1970 Balamuth 128/2

13 Claims, 3 Drawing Figures

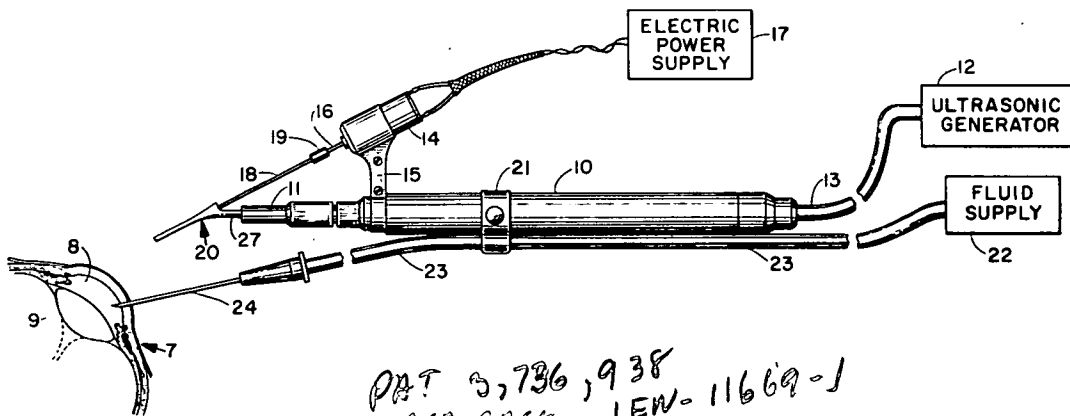

PAT 3,736,938
 NASA-CASE - LEW-11669-1
 N73-27062

OPHTHALMIC METHOD AND APPARATUS

ORIGIN OF THE INVENTION

The invention described herein was made jointly by a non-Governmental inventor and by employees of the United States Government. The invention may be manufactured and used by or for the Government for governmental purposes without the payment of any royalties thereon or therefor.

BACKGROUND OF THE INVENTION

Removing cataracts from eyes is an extremely delicate task. Up to the present time the most generally used operative method involves making an incision of about 180° around the cornea and teasing the lens out of its position with a suitable instrument. Such an operation takes on the order of 45 minutes.

In the last few years devices have been developed which utilize ultrasonic vibrations to drive cutting heads of various configurations, as for example, chisel shaped or pointed members. Liquid supplied to the eye for cleansing and for maintaining a specified pressure in the eye is withdrawn by suction devices.

In the past, the liquid and macerated lens material have been withdrawn through a conduit connected to a suction means such as a vacuum pump. Because of the small size of the conduit and the tendency of the ultrasonic vibration to harden macerated lens material, clogging of the conduit can occur causing erratic variations in suction which could cause the eye to collapse. Furthermore, such clogging can cause dangerous pressure to be impressed on the eye by fluid being supplied thereto. To avoid both excessive suction and pressure in the eye, past systems have utilized complicated and expensive devices to control and adjust the pressure and the suction of the liquid being supplied to and withdrawn from the eye, respectively.

Other arrangements have included an internally threaded tool having cutting members at one end and which is vibrated both longitudinally and about its axis with a rotary motion. The ultrasonic motion in combination with an internally threaded passage effects a pumping action. However, the pumping action is difficult to maintain with regard to viscous materials of the eye which once liquified, tend to harden if not quickly removed from the area of ultrasonic vibrations.

OBJECTS AND SUMMARY OF THE INVENTION

It is an object of the invention to provide an improved method for removing material and components from an eye.

It is an additional object of the invention to provide a method and apparatus for removing materials or components such as the lens from an eye wherein excessive pressure is not built up in the eye by fluid being supplied thereto.

It is another object of the invention to provide an apparatus for macerating the lens of an eye and for positively evacuating the macerated material without endangering the eye with excessive suction or negative pressure and without requiring complex and expensive suction and pressure control devices.

Still another object of the invention is to provide a rotating macerating action in coaction with an ultrasonic vibratory macerating action for removal of the lens of an eye.

Yet another object of the invention is to provide an ophthalmic probe of the foregoing type wherein liquid is supplied to the operative site to increase the ultrasonic coupling and which liquid is evacuated from the eye with the macerated material.

A further object of the invention is to provide an apparatus which can be used to remove vitreous and vitreous opacities from the posterior chamber of an eye; hemorrhage from both anterior and posterior chambers; iris and pupillary adhesions; and matter causing blockage in angle block glaucoma.

BRIEF DESCRIPTION OF THE DRAWINGS

FIG. 1 is a pictorial drawing of a medical instrument embodying the invention.

FIG. 2 is a longitudinal cross-sectional view of the operative head of the medical instrument.

FIG. 3 is a longitudinal cross-sectional view of an embodiment of the invention wherein liquid is supplied to the operative sight through the operative head.

DESCRIPTION OF A PREFERRED EMBODIMENT

While the apparatus embodying the invention will be described with respect to removing the lens from an eye, it can be used to remove other matter and components from an eye. For example, the ophthalmic instrument is useful for performing a vitrectomy in which vitreous or vitreous opacities are removed from the posterior chamber. It may also be used for removal of hemorrhage from both anterior and posterior chambers. Removal of iris and pupillary adhesions can also be accomplished by use of the ophthalmic probe embodying the invention.

Referring now to FIG. 1, there is shown a handpiece 10 from which extends an axially vibrating member 27. The handpiece 10 is connected to an ultrasonic generator 12 by means of a cord 13. The handpiece 10, the cord 13 and the ultrasonic generator 12 are commercially available items. A drive means such as miniature electric motor 14 is attached to the handpiece 10 by means of a support bracket 15 which positions the motor 14 such that its shaft 16 is at an angle to the longitudinal axis of the handpiece 10. It will be understood that motor 14 may be any suitable rotary means such as a pneumatic or electric motor. An electrical power supply 17 energizes the motor 14 such that it operates at speed sufficient to provide pumping action of the apparatus which will be described hereinafter. The motor shaft 16 should rotate at a speed of at least 1,600 revolutions per minute (RPM) with the preferable speed being between about 2,600 to 30,000 RPM. The motor shaft 16 drives a rod 18 through a coupling 19. The rod 18 extends into an operative head 20, which as will be explained presently, is utilized to remove the lens from an eye.

It has been found in cataract operations, that the danger of collapse of the eye may be avoided by supplying fluid under pressure to the eye. According to the present invention a control valve 21 is mounted on the handpiece 10 to control fluid being supplied from a fluid supply 22 via a conduit 23 to a hypodermic needle 24 which has been inserted into an eye 7, the tip of the needle being positioned in the anterior chamber 8. The fluid supply may be a bottle containing a buffered saline solution. The pressure of the fluid is adjusted to be between about 15 and 26 mm of mercury by raising or lowering the height of the bottle. A suitable valve (not

shown) connected in the conduit 23 between the bottle and the needle controls the flow rate.

Referring now to FIG. 2 there is shown a longitudinal cross-sectional view of the operative head 20 wherein parts corresponding to those in FIG. 1 are identified by like numerals. The operative head 20 comprises a housing 25 having a longitudinal passageway 26 extending therethrough and a stem 27 which extends from the housing 25 at an angle to the longitudinal passageway 26. Stem 27 is retained in a guide member 11 of hand-piece 10. Housing 25 serves as a sheath for rod 18. To prevent the ultrasonic vibrations of member 27 from producing stresses which might cause it to separate from the housing 25, the stem 27 merges into the housing 25 along the curve 28.

One end of the rotating rod 18 may extend slightly out of the housing 25 and is provided with cutting edges 29 which may be raked or sloped in the direction of spiral grooves 30 which extend longitudinally along the rod 18 from the cutting members 29 to a point outside of the housing 25. One end of the housing 25 forms an annular cutting edge 31 which is concentric with the rod 18 and adjacent to the cutting edges 29 of the rod.

The one end of the rod 18 may be flat rather than having raked cutting edges. The annular edge 31 may be positioned axially above, below, or flush with the end of rod 18. For maximum macerating action, the annular edge is positioned slightly above the end of rod 18. However, for maximum safety, the annular edge 31 is preferably flush or below the end of the rod 18.

In an actual eye operation, the annular edge 31 of the housing 25 is inserted through a puncture which has been made in the cornea of the eye 7 until it engages the lens 9 of the eye 7 shown in FIG. 1. The rotation of the cutting edges 29 and the ultrasonic vibration of the annular edge 31 coact to macerate the lens material. Prior to inserting the housing 25 through the cornea, a hypodermic needle 24, as shown in FIG. 1, is inserted into the chamber 8 through a puncture. The puncture which is to receive the housing 25 allows fluid to escape thereby avoiding excessive pressure until the instrument begins to evacuate material.

The macerated material together with the liquid being supplied to the anterior chamber 8 are pumped up through the housing 25 by the spiral grooves 30. Advantageously, the removal of the liquid and lens material is accomplished without undue suction or vacuum being applied to the eye, thereby avoiding risk of damage to the eye by such vacuum or suction.

FIG. 3 is a longitudinal cross-sectional view of an alternate embodiment of the invention and parts corresponding to FIGS. 1 and 2 are identified by like numerals. In FIG. 3 a double wall coaxial tube 32 is disposed around the housing 25 and extends toward the operative end of the housing 25 but terminates short of the annular cutting edge 31. The tube 32 is provided with sealing means and an annular plenum-chamber 33 through which a desired liquid may be directed into an annular space 34 between the walls of the tube 32. The liquid serves to maintain a slight pressure in the eye; to lubricate and cool the rod 18 and the housing 25 to increase the ultrasonic coupling; and to function as a carrier for the macerated material. The tube 32 does not vibrate with the housing 25 and thereby avoids atomizing the liquid being supplied to the operative tip through the annular space 34. The liquid is removed

from the operative site by the spiral grooves of rod 18 as in the structure shown in FIG. 2.

It will be understood that the invention described above may be changed or modified by those skilled in the art without departing from the spirit and scope of the invention as set forth in the claims appended hereto.

What is claimed is:

1. A method of removing material from an eye comprising the steps of:

- 10 rotating a tool member comprising a rod having at least one cutting member at one end and a spiral groove extending longitudinally from said cutting edge along said rod;
- 15 disposing a tubular sheath over said rod; ultrasonically vibrating said sheath along its longitudinal axis;
- 20 inserting said rod and sheath through the cornea; supplying an incoming buffered vehicle solution to the anterior chamber of the eye; and
- 25 engaging matter to be removed with both said sheath and said cutting member to macerate said matter, the macerated material being evacuated from the eye by said spiral groove.

2. The method of claim 1 wherein the step of supplying said solution consists of inserting a hollow needle through the cornea of the eye prior to inserting said tool member and supplying said needle with said buffered vehicle solution at a pressure of from about 15.6 mm to about 25.8 mm of mercury.

3. The method of claim 2 wherein said rod is rotated at a speed sufficient to produce pumping evacuation of macerated material and liquid.

4. Apparatus for removing matter from the interior of an eye comprising:

- 35 a rod having at least one cutting edge at one end and at least one spiral groove extending from said cutting edge along said rod;
- 40 drive means for rotating said rod;
- 45 a housing disposed over said rod, said housing including a passageway in which said rod rotates freely, said housing being thin-walled adjacent to said one end of said rod to form an annular cutting edge;
- 50 means for imparting ultrasonic movement to said housing; and means for supplying an incoming buffered vehicle solution to the anterior chamber of the eye.

5. The apparatus of claim 4 wherein said cutting edge extends radially and slopes in the same direction as the spiral groove.

6. The apparatus of claim 4 wherein a stem extends from said housing at an oblique angle to said passageway for connection to said means for imparting ultrasonic movement to said housing, said stem merging into said housing along a curve.

7. The apparatus of claim 4 and including a hollow needle for supplying fluid to the eye and a source of liquid connected to said needle.

8. The apparatus of claim 7 and including flow control means interposed between said hollow needle and said source of liquid.

9. The apparatus of claim 8 and including a handle, said flow control means being disposed on said handle.

10. The apparatus of claim 4 wherein said drive means rotates at a speed greater than 1,600 RPM.

11. The apparatus of claim 4 wherein said one end of said rod is flat.

12. The apparatus of claim 4 wherein said one end of said rod is flush with said annular cutting edge.

13. The apparatus of claim 4 wherein said drive means rotates said rod at a speed between about 2,600 and 30,000 RPM.

* * * * *