

101970510

RADIATIVE COOLER FOR SPACECRAFT

By John E. McCullough*

ABSTRACT

The design, construction, and testing of a passive radiative cooler that provides solutions to the design problems of withstanding mechanical stress, achieving the required thermal isolation, and maintaining optical alinement, cleanliness, and integration with the spacecraft are described in this report.

INTRODUCTION

The passive radiative cooler provides a simple, reliable means of maintaining a detector in a satellite-borne optical system at its required cryogenic operating temperature. This device is able to cool a low-power-dissipation optical detector to temperatures of approximately 100° K by virtue of its ability to radiate more thermal energy to deep space than it receives from other parts of the spacecraft, the sun, and the earth.

For maximum thermal isolation, mechanical connections between the radiator and the spacecraft must be minimized. This is normally achieved by the use of guy-wire supports or nonmetallic structural elements with a large length-to-cross section ratio. However, these traditional types of supports for cryogenic components are not appropriate for supporting radiative coolers because they cannot withstand the dynamic environment of launch and they cannot provide the precise alinement of the detector relative to associated optical components. Additionally, nonmetallic materials are sources of optical-system contaminants like water vapor or volatiles that evolve under space-vacuum conditions.

DESIGN CRITERIA

The complete design specification for a passive radiative cooler suitable for spacecraft use must include the following requirements as a minimum.

1. Mechanical requirements
 - a. Survive launch and orbit-insertion mechanical environment
 - b. Maintain optical alinement of cooled elements and orientation with respect to the remainder of the optical system
 - c. Use dimensionally stable materials

*Arthur D. Little, Inc., Cambridge, Mass.

- d. Operate reliably
- e. Have minimum weight
- 2. Thermal requirements
 - a. Be able to reach required temperature levels while viewing deep space
 - b. Reject heat inputs from the spacecraft (both radiative and conductive) as well as radiant thermal inputs from planetary and solar sources
- 3. Optical requirements
 - a. Maintain optical element spacing and alignment at operating temperatures
 - b. Position optical elements to allow focus adjustment and secure locking in final position
 - c. Maintain cleanliness of optical elements before and after orbit insertion
 - d. Duplicate the properties of an optical-quality mirror with the radiative-energy reflecting surfaces
- 4. Vacuum and cryogenic requirements
 - a. Use construction materials suitable for space environments
 - b. Consider the material properties at cryogenic temperatures
 - c. Use thermal-insulation techniques that are equivalent to multiple-reflective-layer insulation systems

DESIGN

The design philosophy of the cooler described in this report is that a surface thermally isolated from its mounting will radiate thermal energy to deep space, eventually reaching cryogenic temperature levels. However, to reach these temperatures, the surface must be shaded from sunlight and be oriented such that it cannot "see" portions of the spacecraft or earth that act as sources of energy radiated back to the cooling element.

The basic right conical configuration and size of the cooler discussed in this report were derived using thermal-analysis techniques from basic requirements of operating temperature, bias-power heat load, location on the spacecraft, spacecraft configuration, and orbit parameters. The mechanical design of the cooler started with the subsequent shape and size requirements so generated as well as limits on the allowable heat leak or flow of thermal energy between the mounting surface and the cooling element. The design presented in this report results from consideration of all of the design criteria.

Support Element

From previous experience in the design of cryogenic equipment, it was known that the design of the support elements was the most critical aspect of the whole cooler design problem. The support elements must be rugged enough to survive extreme mechanical environments yet have very low thermal conductance. Additionally, they must maintain precise alignment of the cooler stages, such that a detector mounted on the innermost element of the cooler would maintain accurate alignment with respect to the associated optical system attached to the cooler's outermost element. Three supports are used to locate each stage. The supports are located in the plane of the supported component center of gravity to eliminate eccentric dynamic loading. All major components of the cooler were designed as bodies of revolution because this shape was most convenient for the reflective interior of the outer stage and also because this configuration is easily manufactured by standard fabrication equipment, has high stiffness per unit weight, and can be readily analyzed to determine deflection under load and natural frequency modes.

Radiative Cooler

The radiative cooler (fig. 1) consists of three major components: an outer stage, an inner stage, and a mounting ring. The outer stage is a truncated cone, the large end of which is open and flanged around the rim. The inner stage, which is mounted inside the small end of the outer stage, consists of a structural disk and a cover plate that is bolted to it. The mounting ring surrounds the outer stage and provides a means for mounting the radiator to the associated optical system. The inner stage is supported within the outer stage at three equally spaced points around the perimeter, with its center of gravity in the plane of the support elements. The latter unique design provides strong mechanical support at room temperature, so that the cooler will withstand the shock and vibration of launch, and high thermal resistance in the space environment. The outer stage is positioned within the mounting ring by three similar support elements in the plane of its center of gravity.

Optical Design

The optical detector is attached to the structural disk of the inner stage, facing toward the small end of the conical outer stage. The detector can be inserted into or removed from the cooler assembly simply by removing the inner-stage cover plate. The lens system used in conjunction with the detector is attached to the outer stage with the aid of a lens holder. Threads on the exterior surface of the lens holder mate with a tapped section in the outer-stage structure; for focusing adjustment, the lens holder can be moved axially with respect to the detector by rotating it in the appropriate direction.

Thermal Design

The interior surface of the outer stage is highly polished to minimize radiative thermal-energy transfer to the inner stage and to reject solar energy that strikes the cooler at angles nearly perpendicular to the axis of the cooler. The outer flange area

of the outer stage serves as a heat radiator by virtue of its special α/ϵ thermal control coating. Except for this flange, the outer stage is covered by a multiple-reflective-layer blanket, which passes between the outer stage and mounting ring to reduce radiative heat transfer to the outer stage from the cooler surroundings.

When the radiative cooler is exposed to a low-temperature heat sink in vacuum, it radiates thermal energy to this sink from the inner- and outer-stage surfaces. Temperature reductions in the two stages cause the support elements to decouple, resulting in an additional temperature drop. The outer-stage element reaches an equilibrium temperature when its total conductive and radiative heat inputs balance its total radiative output to the heat sink. Similarly, the inner-stage equilibrium temperature will reflect a balance between its total radiative and conductive heat inputs and its radiative output.

To achieve an inner-stage temperature of approximately 100°K , heat inputs to both stages must be minimized in every way possible. For this reason, multiple-reflective-layer radiative insulation is used around both the inner and outer stages, and very fine 0.10 to 0.13 millimeter (0.004 to 0.005 inch) electric wiring is used to convey signals from the detector to the terminal strip on the mounting ring. These wires are typically stainless steel and are encased in Teflon tubing in such a way that they can withstand severe mechanical stress without breaking.

All construction materials used in the cooler are space qualified, and the quantity of nonmetallic materials is minimized. In addition, all parts are scrupulously cleaned before final assembly to maintain the cleanliness of the optical system contained within and to minimize the evolution of adsorbed contaminants from component surfaces. Volatiles emitted by cooler components could easily render the optical system inoperative by coating the elements with condensed vapor or ice.

FABRICATION TECHNIQUE

The major components of the radiative cooler (fig. 2) were machined from solid billets of 6061-T6 aluminum. This material was chosen because it has good mechanical properties, can be readily machined to precise tolerances with standard equipment, is readily available in large billets of uniform temper and homogeneity, can be made dimensionally stable through heat treatment, and is a suitable substrate for nickel plating and polishing. Machining these components from solid billets has proved to be the best way to avoid encountering material nonhomogeneities during fabrication, especially in the conical reflector surface.

After rough machining to within 2.54 millimeters (0.10 inch) of final size, the inner- and outer-stage components were subjected to a thermal stabilization to guarantee dimensional stability during repeated thermal cycling from room temperature to cryogenic temperatures (less than 100°K (-280°F)). After thermal stabilization and final machining of the major parts, the parts were positioned relative to one another in their final configuration and holes for the three support elements were line bored in the inner and outer stages. In this way, precise alignment of the two stages and the mounting ring was achieved and proper functioning of the support element was ensured.

The conical interior surface of the outer stage was prepared for optical polishing in the following way. First, it was polished to remove the majority of machining marks. Next, it was electroless nickel plated. Finally, it was polished with standard optical lapping materials; the technique used was an automated process that was developed especially for polishing conical surfaces to a quality approaching that of an optical mirror.

The evolution of this polishing technique was guided by visual comparison of the polished surface with reference surfaces having the desired reflective qualities. This comparison was made by replicating the polished surface and comparing this to replicates of high-quality optical surfaces (mirror or flats) as well as replicates from surfaces with known thermal control or reflective characteristics. This comparison was made by visual examination of photomicrographs of the replicates made at magnifications as much as 25 000 times, using electron-beam microscopy techniques.

ASSEMBLY

Cooler assembly started by building up the inner stage. Following this, the inner stage was positioned within the outer stage by three support elements so that its concentricity relative to the outer stage was held within 0.038 millimeters (0.0015 inch) T.I.R.

After a multiple-reflective-layer blanket was placed over the outer stage, the mounting ring was positioned by its support elements so that the concentricity of the mounting ring relative to the outer stage was maintained within 0.025 millimeters (0.001 inch) T.I.R.

The internal electrical wiring of the cooler was connected to a terminal block bolted to the mounting ring; pins on the terminal block are readily accessible for connection to the associated optical-system wiring.

After the detector was inserted in the central counterbore of the inner stage and bolted in place, the detector leads were soldered to adjacent terminals on the inner-stage structure. Finally, the inner-stage cover was bolted in place, completing the cooler assembly.

TEST PROCEDURE AND RESULTS

The fully assembled radiative cooler (fig. 3) was thermally tested in a vacuum chamber equipped with a liquid-nitrogen-cooled shroud. The cooler was oriented so that only its forward portions viewed this heat sink, while the rear portions were surrounded by a shroud maintained at room temperature. With this apparatus, successful operation of the cooler can be verified and temperature achievement measured. These data can be extrapolated by thermal-modeling techniques to predict orbital thermal performance.

Data on temperature as a function of time were taken for the inner and outer stages during the cooldown process. Thermal equilibrium was reached approximately 24 hours after the chamber was evacuated, and the shroud temperature was reduced to liquid nitrogen levels. At equilibrium, the temperatures of the inner and outer stages were 102° and 178° K, respectively.

Following thermal testing, the cooler was mounted to a test fixture and subjected to mechanical environment testing, which consisted of flight-acceptance-level sine and random vibration. The random vibration portion of this specification produces 11.3g root mean square acceleration for 2 minutes in each axis. During this testing, the cooler was covered with a large, clean plastic bag to protect it from ambient contamination. The cooler was free to move in all directions without contacting the bag or causing undue motion of the bag.

After this acceptance-level vibration test, the cooler was again mounted in the thermal-vacuum chamber for final optical focusing adjustment and system characterization. The lens mounted on the outer stage was focused by rotating the lens-holder component with a special drive tool mounted on a shaft passing through a rotary feed-through in the vacuum-chamber wall while the cooler was at operating temperature. After focusing, the most sensitive axis of the detector optical system was established using a special translatable infrared source and commensurate optical-measuring equipment.

During these measurements, it was established that the maximum radial movement of the detector axis relative to the lens axis was less than 0.025 millimeter (0.001 inch) as the cooler went from room temperature to operating temperatures. Axial motion of the detector relative to the lens vertex was found to be approximately 0.025 millimeter (0.001 inch) over the same temperature range. No contamination was detected on the optical system after extensive thermal and mechanical testing of this unit.

CONCLUDING REMARKS

The radiative cooler described is a simple, rugged device with proven capability for maintaining satellite-borne optical detectors at temperature levels of 100° K. It is a passive device with intrinsic high reliability that can be readily integrated and aligned with precise optical systems. The design and the materials used in the construction of this cooler promote long trouble-free operating life in the space environment with maximum protection of the low-temperature optical elements from contamination.

DISCUSSION

A. L. Wade:

What information do you have about the criticalness of the contamination of the cold surfaces in orbit? Also, what material was used for support between the inner and outer stages?

McCullough:

The orbital performance information that we are able to talk about is not complete enough to draw conclusions about possible contamination phenomena. We have been cleared to talk about only those aspects of the cooler design that I have presented.

R. L. Samuels:

Was surface-finish deterioration during orbital lifetime investigated?

McCullough:

Yes, the finishes that we selected are considered to be as good as any available for the maintenance of the required thermal properties during extended exposure to the space environment.

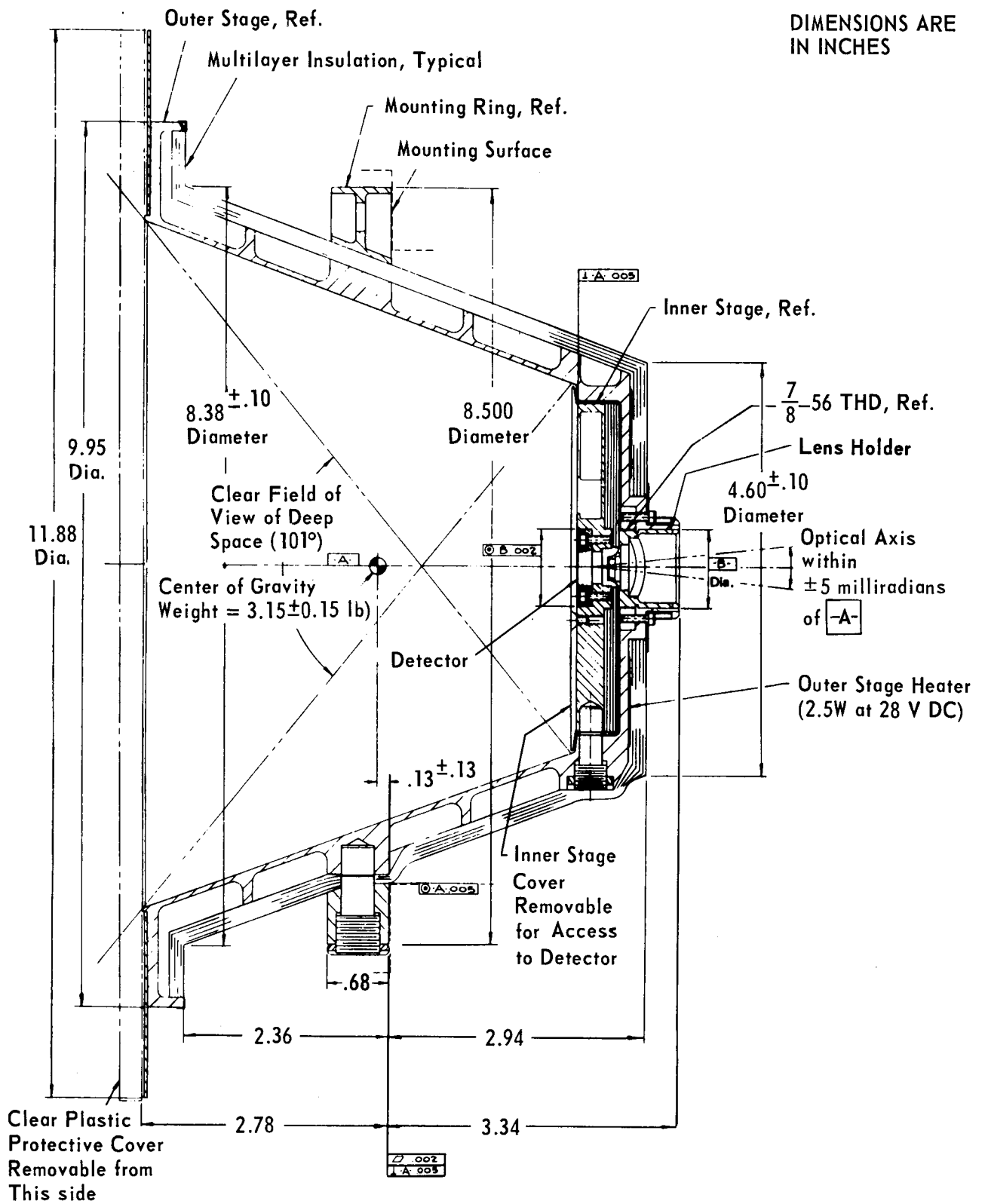
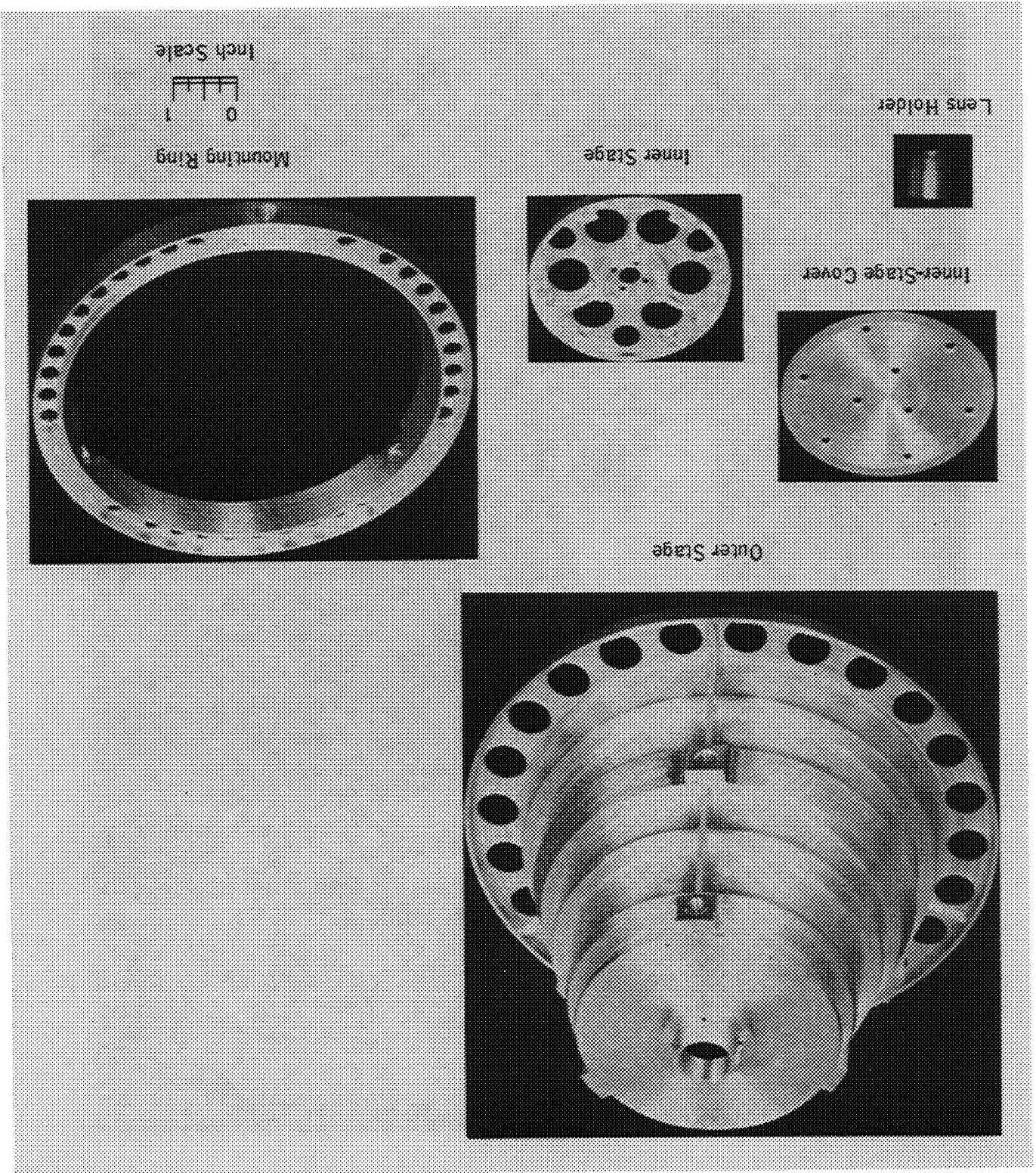

Figure 1. - Radiative cooler assembly.

Figure 2. - Radiative cooler major components.



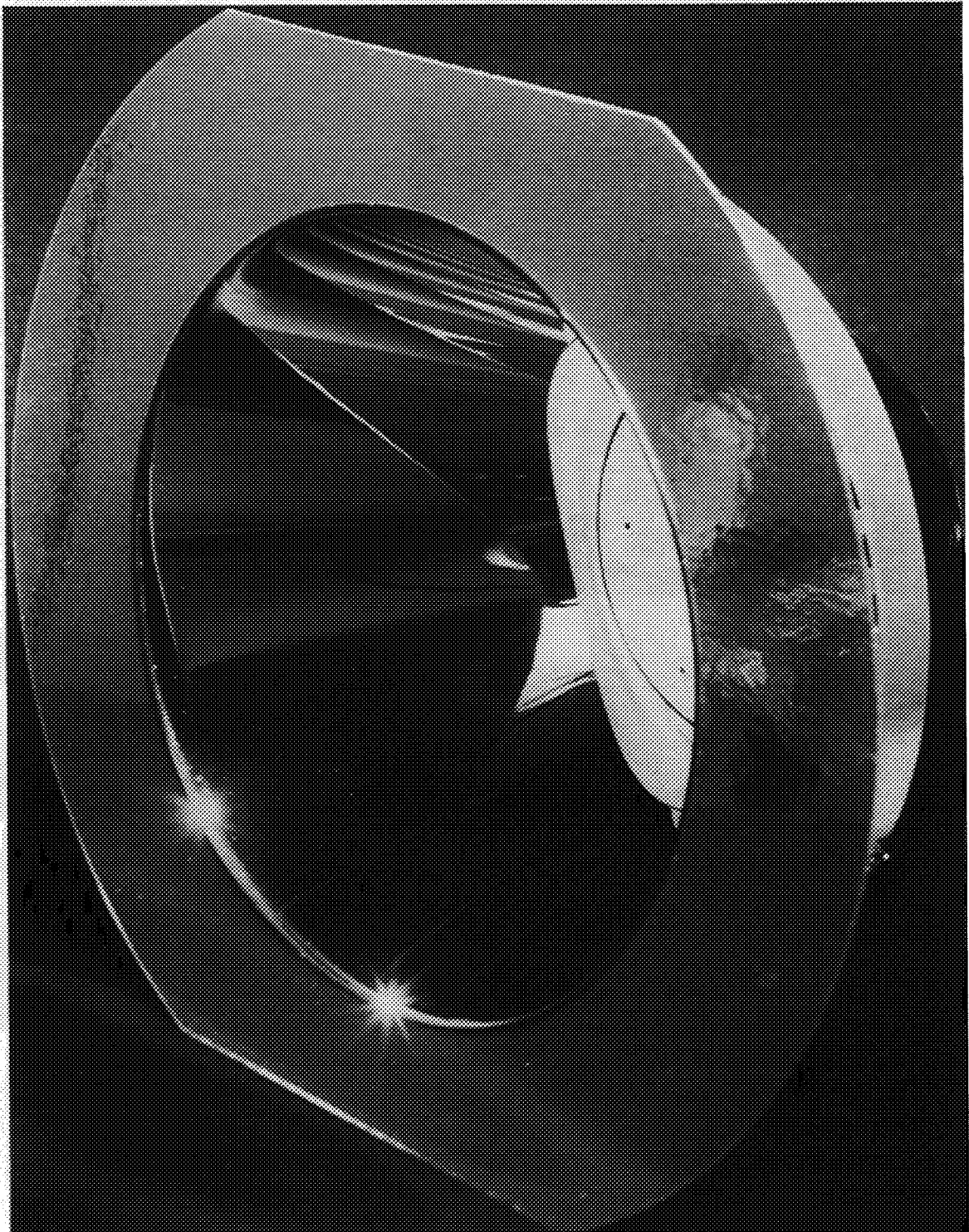

Figure 3. - Passive radiator for detector cooling.