

April 1974

B73-10510

NASA TECH BRIEF

John F. Kennedy Space Center



NASA Tech Briefs announce new technology derived from the U.S. space program. They are issued to encourage commercial application. Tech Briefs are available on a subscription basis from the National Technical Information Service, Springfield, Virginia 22151. Requests for individual copies or questions relating to the Tech Brief program may be directed to the Technology Utilization Office, NASA, Code KT, Washington, D.C. 20546.

Automatic PCM Guard-Band Selector and Calibrator

The problem:

Before data are recorded on analog recorders, the recorders must be calibrated. The standard calibration method requires manual adjustment, of some channel recorders, to one set of guard-band calibrations. The remaining channels are then adjusted for the other set of guard-band calibrations. Eight switches, representing each bit of the calibration word, are then switched through the required calibration percentages. Here, the technician must determine which guard band to set up and which switches to use for each calibration level. Clearly, this method takes time and is subject to human error.

The solution:

An automatic method for the selection of the proper guard band eliminates the human error and speeds up the calibration process.

How it's done:

The figure is a simplified block diagram, which illustrates the calibrating technique for a PCM (pulse-code-modulation) dual-guard-band system. The system is equipped with two storage devices containing NAND gates. Each of these, the low and the high guard-band devices, stores six calibration levels, representing 10, 20, 40, 60, 80, and 100 percent, respectively. The calibration levels are initiated in the calibration control with an up/down counter, through a switch on the front panel. Each bit of the calibration word is wired from the patch panel to a two-input NAND gate which is used as a calibrate-level storage device. Six two-input NAND gates are OR connected at the output for each bit of the calibration level required. One input of these gates stores the calibrate level, while the other input is enabled automatically by the up/down counter.

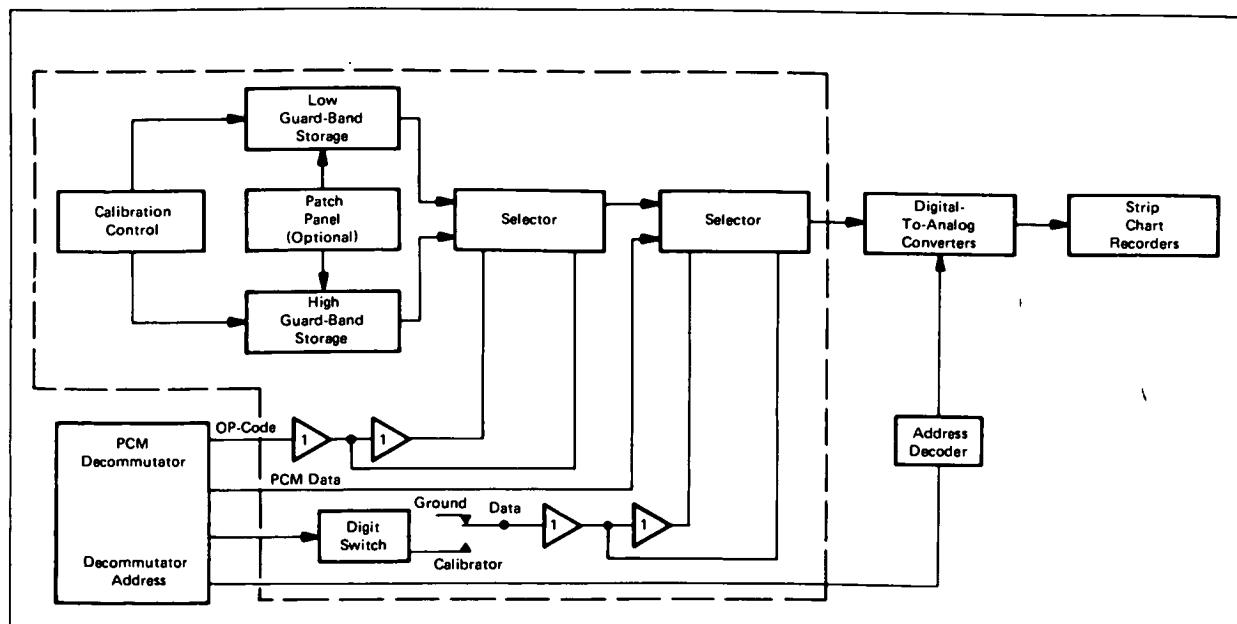

Automatic PCM Guard-Band Selector and Calibrator

(continued overleaf)

Outputs of the low and high guard bands are fed to the calibrate selector. The selector is enabled by the PCM decommutator, which is programmed to generate a pulse to permit selection of the proper guard band for a particular channel. This pulse is referred to as OP Code. The output of the first selector is fed to the second selector, which selects either of the data or calibrate functions. All channels can be calibrated by engaging the Data/Cal switch (not shown).

There is an option which allows a single channel to be calibrated, independently of other channels. The address tag from the decommutator for each data channel is fed to the single-channel calibrate decoder. The address of the single channel to be calibrated is programmed on the digit switch. When the address from the decommutator and the address programmed on the digit switch are identical, a pulse is generated which gates the calibrate signal through instead of the data for that particular channel.

Notes:

1. The entire system is designed on 3- by 4-inch (8- by 10-cm) printed-circuit cards and may be used with any PCM system.
2. Requests for further information may be directed to:
Technology Utilization Officer
Kennedy Space Center
Code AD-PAT
Kennedy Space Center, Florida 32899
Reference: TSP73-10510

Patent status:

Inquiries concerning rights for the commercial use of this invention should be addressed to:

Patent Counsel
Kennedy Space Center
Code AD-PAT
Kennedy Space Center, Florida 32899

Source: T. T. Noda of
New Mexico State University
under contract to
Kennedy Space Center
(KSC-10812)