

NASA TECH BRIEF

Ames Research Center



NASA Tech Briefs announce new technology derived from the U.S. space program. They are issued to encourage commercial application. Tech Briefs are available on a subscription basis from the National Technical Information Service, Springfield, Virginia 22151. Requests for individual copies or questions relating to the Tech Brief program may be directed to the Technology Utilization Office, NASA, Code KT, Washington, D.C. 20546.

Miniaturized Haploscope for Testing Binocular Vision

A miniaturized, motorized haploscopic device has been developed which can reproduce virtually all of the binocular stimulus conditions (target configuration, vergence angle, and accommodative distance) used to test binocular performance; the diagram below indicates the primary structural features.

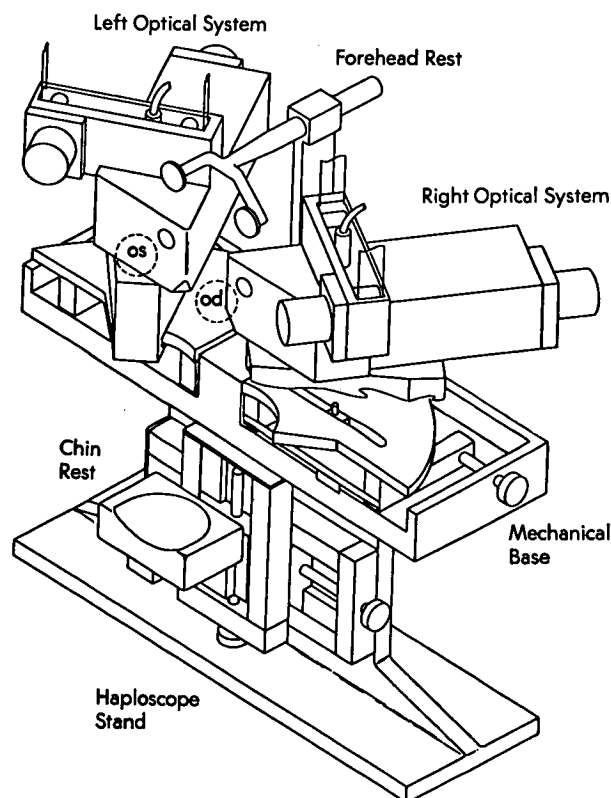

The optical system for the right eye (second diagram) is a mirror image of that for the left eye; as shown, the subject views targets through the two

front surface mirrors and the +10 diopter lens which is mounted so that its rear focal point is coincident with the entrance pupil of the subject's eye. The Porro prism changes the distance between the lens and the film plane aperture which is located just above a small right-angle prism. The optical system functions as a Badal optometer, that is, the vergence angle (at the eye) of light from the film-plane aperture changes linearly with the distance between the lens and the aperture; because the visual angle of the target at the eye remains constant as the vergence of light at the eye changes, the same imagery can be used for near or far testing. The image is a photograph presented on high-contrast high-resolution, 16-mm black-and-white film; electronic controls permit

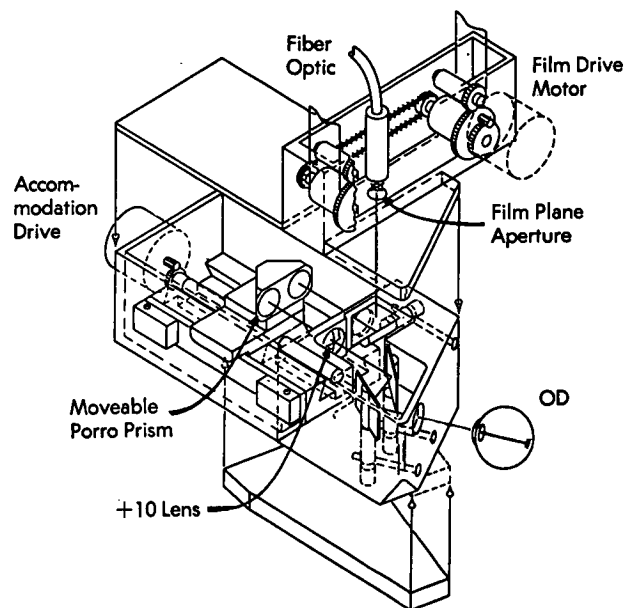

(continued overleaf)

the operator to present any one of 99 separate frames of each right and left test film. A fiber-optic bundle distributes the light from a central source to a diffusing screen mounted just above the film-plane aperture.

The mechanical base permits rotating the optical system precisely about the center of rotation of each eye; the base is structurally rigid so that the vergence angles of the optics are accurately determined. A vergence-angle drive motor counterrotates two threaded shafts through a miter gear arrangement; as the shafts turn, blocks on the right and left sides of the base are moved symmetrically inward or outward. The blocks are rigidly supported by a set of fixed parallel rods running from one side of the mechanical base to the other. A platform with a V-groove cut into its curved inner and outer edges is mounted over each driving block, and a vertical drive pin attached to the top of each block extends up through a slot in the platform and moves back and forth as the driving block is moved. A trolley mounted over each platform has three V-shaped wheels which run in the V-grooves; the drive pins also extend into the trolleys, so that the linear motion of the driving blocks is converted into the curvilinear motion of the trolley mechanisms. Each trolley is specially constructed to minimize friction and backlash.

The mechanical base permits vergence angle changes from 22 degrees eso to 14 degrees exo for each eye; interpupillary distance adjustments are made by moving each driving block inward or out-

ward until the distance between the centers of the radii of the curved tracks are equal to the interpupillary distance of the subject. The X-Y adjuster for the chin rest is also on the mechanical base. Alignment of the apex of the subject's corneas is accomplished with the aid of two small fixtures mounted on the outer portions of the right and left optical systems; the examiner sights across the fixtures and moves the subject's head forward or backward by means of a forehead adjuster.

All the subsystems of the electronic controls are open-loop and solid-state-controlled and, with the exception of the vergence angle drive, utilize dc stepping motors as prime movers. Arrangement is also made for readouts of each variable.

Note:

Requests for further information may be directed to:

Technology Utilization Officer
Ames Research Center
Moffett Field, California 94035
Reference: TSP 73-10492

Patent status:

NASA has decided not to apply for a patent.

Source: Thomas A. Decker of
Baylor College of Medicine
under contract to
Ames Research Center
(ARC-10759)