

NASA TECH BRIEF

NASA Pasadena Office



NASA Tech Briefs announce new technology derived from the U.S. space program. They are issued to encourage commercial application. Tech Briefs are available on a subscription basis from the National Technical Information Service, Springfield, Virginia 22151. Requests for individual copies or questions relating to the Tech Brief program may be directed to the Technology Utilization Office, NASA, Code KT, Washington, D.C. 20546.

Heated Bimetal Strip Prevents Damage of Bearings by Vibration

The balls in a ball bearing can vibrate in their raceways during periods of extremely high vibrations (e.g., during a space vehicle launching or when a bearing assembly is subjected to severe shock loading); the vibration may be sufficiently intense to cause the balls to "Brinell" or score the raceways. To prevent damage of bearings, a thrust load often is applied along the axis of the shaft; clearances between the balls and raceways are then minimized, and vibration does not readily occur, but more torque is required during operation because of the added load. Mechanisms which can be used to remove the preloading after launching are seldom used in an aerospace mission because they are inherently bulky, complex, and unreliable. However, bearings can be immobilized during launch with a thrust supplied by a heated bimetallic strip; when the strip cools, normal bearing clearances are reestablished.

The ball bearing shown in the diagram has stationary outer races and rotatable inner races. Contact between the balls and races occurs along lines A and B. Under normal operating conditions, the bimetallic strip, supported between two rigid insulators and acting in the manner of an expansion spring, causes the balls to press against their races; as a result, the two outer races are forced apart and constrained by the preloading mechanism (bolts).

The strip of bimetals is shaped as a split ring; when properly fabricated from a thin sheet, the width of the strip increases when it is heated (by electrical power leads attached to the two ends of the split ring). When the width of the strip increases, the outer races are forced apart, thus pressing the balls tightly

against the inner races. In this manner, the strip applies an axial load to the bearing, the amount of the load being a function of the temperature to which the strip is heated and the physical structure of the strip.

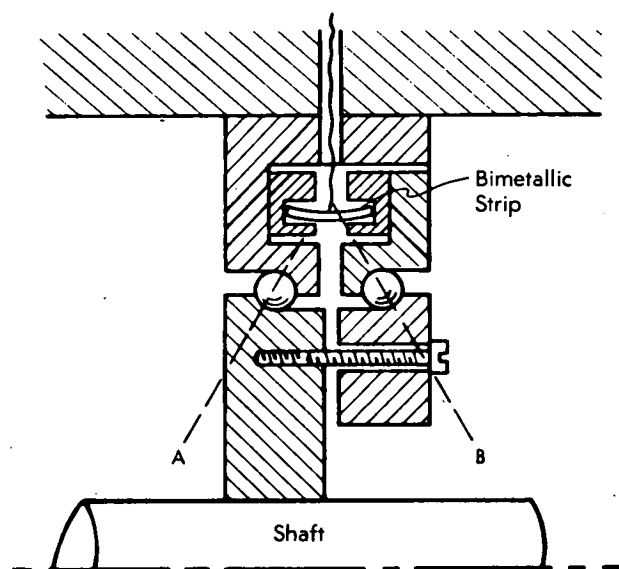

In a typical application in a space vehicle, the bearing is assembled in such a way that the strip, at ambient temperature and by its natural spring action, applies a desired static axial load (typically 2.2 kg) to the bearing. A few moments prior to launching, heat is applied to the strip, causing it to apply a higher axial load (typically 67 kg) to the bearing. Thus, the bearing is held tightly during the extreme vibration that occurs during launch; after launching has been

(continued overleaf)

completed, the heat is turned off and the strip soon returns to ambient temperature, so that it now maintains the axial load required for normal operation.

Note:

Requests for further information may be directed to:

Technology Utilization Officer
NASA Pasadena Office
4800 Oak Grove Drive
Pasadena, California 91103
Reference: TSP 73-10348

Patent status:

Inquiries concerning rights for the commercial use of this invention should be addressed to:

NASA Patent Counsel
Mail Code 1
NASA Pasadena Office
4800 Oak Grove Drive
Pasadena, California 91103

Source: Lloyd J. Derr of
Caltech/JPL
under contract to
NASA Pasadena Office
(NPO-11870)