

NASA TECH BRIEF

Lyndon B. Johnson Space Center



NASA Tech Briefs announce new technology derived from the U.S. space program. They are issued to encourage commercial application. Tech Briefs are available on a subscription basis from the National Technical Information Service, Springfield, Virginia 22151. Requests for individual copies or questions relating to the Tech Brief program may be directed to the Technology Utilization Office, NASA, Code KT, Washington, D.C. 20546.

Electroshock Protection Circuit

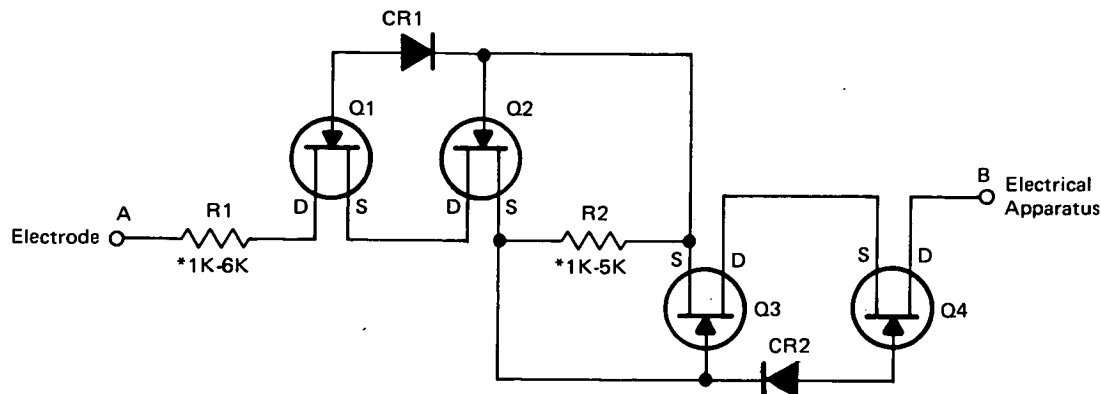

*R₁ and R₂ Electrical Values and Characteristics are Determined by the Particular Application

One of the primary dangers of accidental shock exists during the use of electrocardiographs and electroencephalographs and other electrical apparatus that are attached directly to the patient. The degree of hazard present with bioelectronic instruments can be reduced by proper, careful use, but the possibility of human error still exists.

As part of the Skylab program, an electroshock protection circuit was developed to prevent accidental shock through the electrodes to the test subjects. This circuit is placed between the electrical apparatus and the electrode that is attached to the patient's body.

The circuit, which is shown in the diagram, allows undistorted signal voltage transfer, as long as the current remains low. If a high current tries to flow from terminal A toward terminal B, it will produce a potential difference across resistor R₂ to the extent that the left side of R₂ is at a higher potential than the right side. This potential biases the gate electrodes of the field-effect transistors, Q₃ and Q₄, to produce an extremely high impedance. Similarly, a current flow in the opposite direction is cut off by a bias on the gates of Q₁ and Q₂.

This circuit effectively protects the patient from dangerous electrical shock that might be caused by a

failure in the electrical apparatus. When a 1,000-Hz signal at 141 Vac (rms) is applied to the terminals of the network, the current is limited to approximately 87 μ A.

Notes:

1. This electroshock protection circuit may also be used to protect sensitive electrical measuring circuits.
2. Requests for further information may be directed to:
Technology Utilization Officer
Lyndon B. Johnson Space Center
Code JM7
Houston, Texas 77058
Reference: TSP73-10261

Patent status:

NASA has decided not to apply for a patent.

Source: H. Heskett, J. Meincer,
and A. L. Inglis of
Martin Marietta Corp.
under contract to
Johnson Space Center
(MSC-14222)

Category 02_05