

NASA TECH BRIEF

Lyndon B. Johnson Space Center



NASA Tech Briefs announce new technology derived from the U.S. space program. They are issued to encourage commercial application. Tech Briefs are available on a subscription basis from the National Technical Information Service, Springfield, Virginia 22151. Requests for individual copies or questions relating to the Tech Brief program may be directed to the Technology Utilization Office, NASA, Code KT, Washington, D.C. 20546.

A Closed, Digital Telephone System

A relatively inexpensive, closed-loop telephone system has many features that make it ideal for private telephone networks. This digital system can accommodate sixteen or more telephone or data units and eight, simultaneous two-way conversations through only four interconnecting wires. It uses considerably fewer circuit components than existing systems. It is not particularly bulky or complex, and it requires no central exchange control. Furthermore, it may be dialed or programmed by discrete switches, pushbuttons, or standard dial techniques. All of these advantages add up to a new, highly versatile communications system that is adaptable to a multitude of uses.

The accompanying figure is a block diagram of the system. The simplicity, reliability, and reduced component count are due primarily to the operation and synchronization technique requiring only four interconnecting wires:

1. an address line,
2. a signal or data line,
3. a clock line, and
4. a "common" reference voltage line.

A digital synchronization circuit (not shown) remote from the telephone circuit supplies each unit with an address and clock signal and may be built into one of the telephones.

Several conversations are transmitted over the same line by preceding each data group with an address code that directs the data (in a synchronized time frame following the address) to the particular party called. The address signals are a series of sixteen eight-bit words. The first bit of each word, the sync bit, is

always a "one"; the next four are a binary sequence indicating one of sixteen addresses; and the last three are used for command or control functions. Each address signal is followed by a sync bit and up to fifteen data bits on the data line.

Each telephone has a binary number for a "name". It is stored by hardware for comparison with address numbers and for generation of this number on the signal bus. When a telephone receiver is on the hook, the internal system operates in a not-enabled mode, watching for an address number that is equal to its preprogrammed, fixed, station number. To initiate a call, the caller enters the recipient's "name" into the serial-to-parallel shift register. When the "call" switch is activated, the calling phone stores the recipient's number in a buffer memory and places its own "name" on the data bus in the time slot following the recipient's address. The recipient phone memorizes the calling party's number. When the recipient phone is not enabled, the caller's name is presented to his name comparator. The name is displayed by light-emitting diodes and a bell is rung so that the caller may be identified. When the call is answered, data are channeled to a D/A converter and to the earpiece.

The circuit also includes the timing and control functions necessary for optimal operation. The number of components is reduced by double and triple utilization of the circuit components, yet the flexibility of the system parameters is not reduced. Any number of phones may be accommodated. Analog and digital party lines can be easily included as can other features of standard telephone systems.

(continued overleaf)

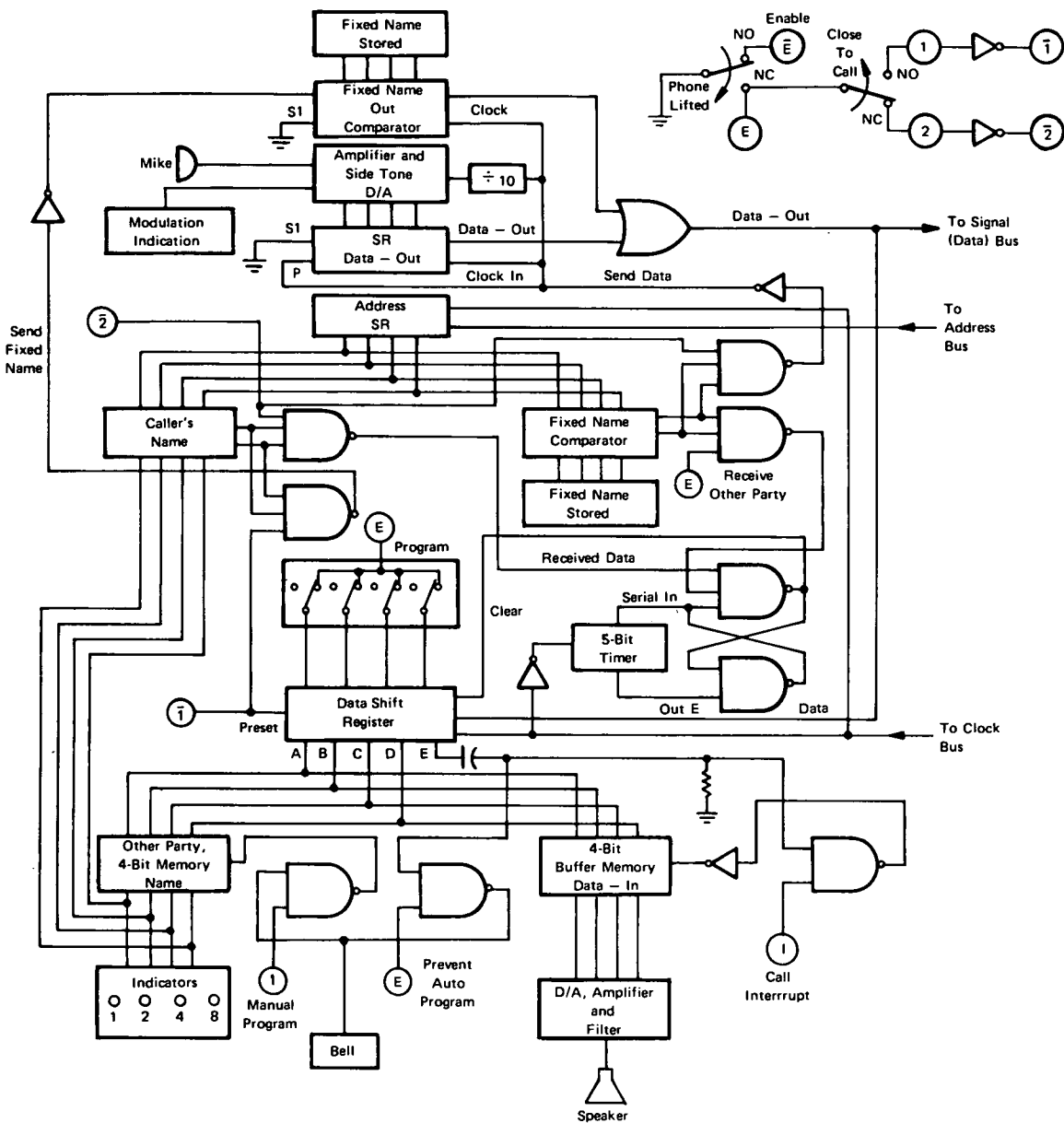

Note:

Requests for further information may be directed to:

Technology Utilization Officer
 Lyndon B. Johnson Space Center
 Code JM7
 Houston, Texas 77058
 Reference: TSP73-10226

Patent Status:

This invention is owned by NASA, and a patent application has been filed. Inquiries concerning non-exclusive or exclusive license for its commercial development should be addressed to:

Patent Counsel
 Lyndon B. Johnson Space Center
 Code AM
 Houston, Texas 77058

Source: L. G. Monford
 Johnson Space Center
 (MSC-13912)