

## PILOT FACTORS INFLUENCING DYNA-SOAR GLIDER DESIGN

By Robert L. Campbell and Herbert G. Shepler  
Boeing Airplane Company

### INTRODUCTION

L  
1  
1  
1  
2  
5

One of the objectives of the Dyna-Soar program is piloted exploration of the hypersonic reentry regime. From an engineering standpoint, the end results of piloted Dyna-Soar flight are a weight and volume increase over that which would be required for nonpiloted flight. The weight and volume requirements for piloted flight are compensated for primarily in two ways:

- (1) The increase in mission reliability due to paralleling pilot and equipment functions and
- (2) The very important, but nonquantitative, aspects dealing with assessment of situations, alternative reaction capability, and reasoning capability beyond that of any known machine.

### DISCUSSION

Some of the factors which influence the design of the Dyna-Soar reentry glider due to piloted flight are breathable atmosphere, protective devices and survival equipment, vision requirements, heat-sink temperature, temperature tolerance, g tolerance, and design margins. All of these factors exist for present piloted vehicles; however, each represents special design considerations due to the environments of the Dyna-Soar vehicle. The atmosphere for breathing must be carried within the glider since the flight altitudes are above those where outside air can be used. High accelerations create the need for protective devices. Survival equipment is needed for emergency conditions, particularly water landings. Direct-vision capability creates a problem in the use of high-temperature transparent materials. Heat-sink temperature and temperature tolerances are important from a weight-saving standpoint. In general, design margins are increased over those which would be used for unmanned flight. Some of these are the 1.4 factor (1.25 for unmanned vehicles) applied to the booster structure and the 10 percent reserve capacity for all expendables.



There has been much discussion of the Dyna-Soar pilot's functions and utilization. This paper presents some of the measures taken to provide the capability to perform those functions and a review of some of the tests conducted to verify the adequacy of the provisions for the pilot.

Figure 1 is a sketch of that portion of the Dyna-Soar vehicle which is specifically concerned with the pilot. The glider height and width in this area are determined by the requirements for the pilot. The cockpit volume is based on a 75 percentile man (this would be a man 70.7 inches tall). The weight associated with the pilot and his ventilated pressure suit is 194 pounds (162 for the man and 32 for the suit). No assessment has been made in this paper for structural weight due to piloted flight because it has been assumed that this compartment would be used for additional payload equipment for unmanned flights. Cooling provisions for equipment in unmanned flight would be provided from the environmental control system provided for the aft equipment bay. The automatic landing system is shown as a reference weight for unmanned flight.

L  
1  
1  
2  
5

The requirement for a breathable atmosphere is not unique to the Dyna-Soar vehicle. Submarines and high-altitude balloons have had to carry the atmosphere for breathing. Weight trade studies have resulted in providing the breathable atmosphere for the Dyna-Soar glider through the storage of a cryogenic (liquid) mixture of oxygen and nitrogen which is the first application of this technique. Results of tests (unpublished) have shown that removal of the mixture from the storage container as a liquid and then vaporized maintains a constant partial pressure of oxygen in the discharge. Where the mixture is taken off the top as a vapor, the discharge is first nitrogen rich and then becomes oxygen rich as the quantity in the tank decreases with time.

An emergency atmosphere is provided for the pilot in the event of malfunction of the normal supply. The supply is sufficient to cover the longest time period for escape which occurs at the end of the second-stage boost. After landing, there is sufficient emergency atmosphere for a 72-hour breathing demand.

The survival kit includes those items necessary for a 72-hour period after landing in the emergency mode. Other items shown in figure 1 are the sonic insulation, instrument panel, windows, and communications and electronic equipment. Some of this equipment is discussed subsequently.

Piloted flight has always created the need for escape; the Dyna-Soar reentry glider is no exception. Figure 2 shows a few of the considerations leading up to the selection of the Dyna-Soar escape system. This figure indicates how the weight varies with pilot safety when



several types of escape systems are considered. It can be seen that the weight increases sharply with increased pilot safety systems. The selection of the forward section of the vehicle as the escape system was based upon maximum pilot safety throughout the complete flight regime. The parts of the flight regime of interest for escape system design and selection are off the launch pad, the high q region of boost, the end of boost, during weightless flight, during reentry, and the landing phase. Escape from anywhere in the flight profile dictated the selection of the system. However sensitive the subject of pilot losses may be, there always remains the engineering trade between vehicle performance as affected by weight and the degree of pilot safety afforded. As long as requirements exist for escape throughout the complete profile, or even throughout the complete boost profile or the reentry mode, the escape system appears to be somewhat complex and heavy. It is difficult to generate specific numbers of losses per thousand missions without the benefit of many actual flights. Data such as these are used to establish trends upon which design decisions can be based.

L  
1  
1  
2  
5

The weight of the equipment provided to accomplish escape is presented in the following table:

Capsule trim surface, lb . . . . .	86
Capsule parachute, lb . . . . .	196
Escape rocket and separation provisions, lb . . . . .	222
Capsule reaction control system, lb . . . . .	138
Battery, inverter, etc., lb . . . . .	60
Electronic apparatus, lb . . . . .	27
 Total weight, lb . . . . .	 729

The capsule trim surfaces assist in producing the proper angle of attack after capsule separation. Both a deceleration parachute and a cluster of three recovery parachutes are used. The escape rocket applies a 25,000-pound thrust for 1 second to the capsule after separation. The reaction control system can be used for capsule orientation for reentry, for stability augmentation, and for maintaining proper attitude in conjunction with the trim surfaces. The battery and other electronic and electrical equipment supply power and control during emergency conditions. These items total 729 pounds.

Figure 3 shows a partial inboard profile wherein the escape provisions have been combined with the equipment provided for normal flight to give a total weight of about 1,400 pounds due to piloted flight. This total weight is about eight times greater than the weight of the pilot alone. The normal-cooling-system weight is less than the emergency-cooling-system weight because the emergency cooling system must cool those electronic devices necessary for pilot escape, whereas the normal cooling system is only chargeable to pilot cooling.

Protective devices which are peculiar to the pilot include the seat and restraint devices, the ventilated pressure suit, and the sonic insulation covering the inside surface of the capsule walls. It has been estimated that the noise level inside the pilot's compartment may be as high as 140 decibels during boost. The helmet will reduce this level by a minimum of 20 decibels. The allowable level is about 135 decibels for 10 seconds. One of the early tasks will be to obtain more definitive data on noise levels through tests. The pilot's seat is positioned forward 15° during the boost phase and 10° back during free flight. The peak acceleration during the Titan-Centaur boost is about 7g and is reached about 3 minutes after take-off. The pilot can easily withstand the boost-acceleration profile.

The design of the Dyna-Soar glider is not affected by solar radiation. Ultraviolet rays are absorbed strongly by the glass in the side windows. Visible light will be handled by suitable diffusers. The planned apogee (300 nautical miles) is well below the strong Van Allen radiation belt. The glider will experience a maximum of about 100 milliroentgens per week. The allowable value established by the Atomic Energy Commission is about 300 milliroentgens per week. The principal hazard of the nuclei particles is when they stabilize by suddenly giving off their energy in a small amount of tissue, which creates an intense ionization for 1 or 2 centimeters of tissue depth. The probability of hits by such particles is extremely low for the Dyna-Soar mission.

The extreme temperature environment encountered during the reentry phase dictates the requirements for cooling systems for both the pilot and equipment. One of the most important parameters in environmental control systems is the temperature to which heat is transferred which is called the heat-sink temperature. It is axiomatic to environmental-control engineers that the weight cost for cooling systems decreases as the heat-sink temperature is raised. Thus, it is possible to get a 150° F heat-sink-temperature cooling system for less weight than a 0° F heat-sink-temperature cooling system for the same heat rejection. The curve on the left-hand side of figure 4 shows this trend of decreasing cooling-system weight as heat-sink temperature for equipment is increased. The curve presented is not for one particular cooling system but may represent several systems at different parts of the curve. On the right-hand side of figure 4 are shown the temperature limitations for man as a function of time. It can be seen that, as the effective temperature surrounding the pilot is increased, the time duration of his tolerance to this temperature decreases. The effective temperature includes the effects of wall radiant temperature and ambient gas temperature. The curves for man are plotted for specific values of humidity and pressure and would shift as these parameters change. The significant feature of these curves is that the weight penalty for cooling the man may be higher on a long time basis than that for equipment but man can stand higher temperatures for short time periods than most electronic equipment.

L  
1  
1  
2  
5

For the Dyna-Soar glider, this feature is very important since water is used as a heat sink. During the later stages of the reentry at low altitude, the heat-sink temperature rises and the equipment temperature rises accordingly. It is necessary to shut off the equipment at touchdown in order to prevent overheating of the equipment. The pilot experiences the same heat-sink-temperature rise but his capability for withstanding high temperatures for short time periods allows for a system design which does not require extra provisions or special operational techniques.

Some of the test work which assisted in the design of the Dyna-Soar vehicle for piloted flight included vision capability, reaction-control simulation, cockpit-characteristics simulation, and centrifuge tests simulating the boost phase of flight.

Vision is one of the ground rules for piloted flight. The degree and type of vision provided will vary with the mission requirements, but all will agree that direct vision is the best way to do the job. Since the weight per square foot of window is about five times the weight per square foot of capsule wall, it is necessary in the design stages to make careful trades between window area and pilot vision requirements. The forward window on the vehicle is covered during most of the reentry because the materials cannot withstand the temperatures. The side windows are not subjected to as high temperatures and are not covered. Figure 5 shows a North American F-86 airplane used in checking out the capability of the pilot to use the side and forward windows of the Dyna-Soar vehicle. The canopy was covered over except for the portions simulating the windows on the Dyna-Soar vehicle. The pilot was positioned in the cockpit with respect to these windows as he would be in the Dyna-Soar cockpit. This was one of the ways in which direct pilot contact with proposed designs was used to select a configuration. Figure 6 shows the altitude and ground track of the vehicle during a 360° landing approach. This is just one of several landing techniques being evaluated. This particular pattern is more critical for sizing the side window than others and was used to size the present side windows. Present efforts have been directed toward increasing side-vision capability along with a reduction in the weight of the window.

The centrifuge at Johnsville, Pa., was used extensively to check the pilot's capability to withstand the accelerations experienced during the boost phase of the Dyna-Soar flight. There are two major differences between piloted flight in the Dyna-Soar glider and in other aircraft. These differences are the operation in a high-acceleration field and the high degree of accuracy required in controlling pitch of the vehicle during boost in order to establish a successful orbit.

Figure 7 shows a comparison between the theoretical boost acceleration of a four-stage solid-propellant ICBM booster, which consisted of

clusters of the Minuteman booster, and the capability of the centrifuge. It can be seen that the maximum acceleration attained was about 8g at the end of the second-stage boost. The total boost period was about 300 seconds, 60 seconds of which were a coast period between the third- and fourth-stage boost. Later developments in the Dyna-Soar program resulted in the consideration of either the Atlas-Centaur or the Titan-Centaur booster in place of the clustered Minuteman booster. The boost-profile accelerations for the Titan-Centaur are shown for comparative purposes. It can be seen that selection of this booster would result in lower magnitudes of accelerations but a longer duration of boost. The maximum value of acceleration would be about 7g and the total boost period would be about 500 seconds. Either of the boost profiles shown would be well within the tolerance limits for a pilot. Onset accelerations are also within human tolerances.

L  
1  
1  
2  
5

Four pilots were used in a total of 100 runs in the centrifuge. The cockpit was fitted with a proper seat and a three-axis side-stick controller developed for the glider. Variables were wind shear, acceleration, and uneven stage termination. The tracking task was a closed-loop simulation of the vehicle dynamics. Figure 8 shows the result of a tracking exercise on the centrifuge. The four-stage boost profile was used. The ID-249 A/ARW cross point indicator was used by the pilot to attempt to follow the theoretical boost profile shown. Tolerances on his track were the lower limits of glider capability and the upper limit which was the recovery ceiling. Approximately 12 to 14 runs had to be made by each pilot before his proficiency was up to that indicated by this curve which was representative of the runs being made after 20 trials. The run was considered a success if at the end of boost the pilot's track equaled the theoretical track which establishes successful orbit at the altitude and speed shown.

Another simulator was used to obtain pilot reactions to other portions of the mission profile. This was a six-degree-of-freedom cockpit characteristics simulator which was used for simulating orbit, reentry, and glide to Mach 1.5 flight. Some of the cockpit instruments used were the side-stick controller and indicators for horizontal and vertical situation, range-to-go, inertial altitude and velocity, and vehicle temperature.

A reaction control simulator was constructed to check out various methods of controlling the vehicle during orbital flight. Figure 9 is a photograph of this simulator which utilized a large air bearing for almost frictionless support. Small nozzles located on the extremities of the simulator discharged nitrogen gas to provide the thrust necessary to move the simulator.

Most of the foregoing discussion has been directed toward those factors which directly influence the design of the Dyna-Soar vehicle

due to piloted flight. The pilots of existing flight vehicles have added to the overall reliability of mission success and the Dyna-Soar is no exception. Figure 10 shows in a qualitative manner that the pilot contributes significantly to the attainment of a successful mission. The figure presents the weight increase as a function of failures (aborts) per 1,000 missions. The plot does not take into account the boost phase of flight. The solid-line curve includes various combinations of the following systems: flight control, guidance, secondary power, and environmental control. At 28 failures per 1,000 missions, it has been assumed that there is no redundancy in these systems. As systems are dualized, the weight increases with an attendant decrease in mission failures. The solid-line curve assumes no effect on mission success due to the pilot. The dashed-line curves show the effect on mission success when the pilot can act to various degrees in parallel with these subsystems. The percentage figures indicate the degree to which the pilot is in parallel with these subsystems. The pilot cannot act completely in parallel with any of these systems but he does have a partial paralleling capability. Although a pilot task and subsystem capability analysis has not been made at this time, it is felt that the Dyna-Soar pilot will be able to contribute to increased mission success through proper integration of man and machine.

L  
1  
1  
2  
5

#### CONCLUDING REMARKS

Some of the factors which have influenced piloted flight of the Dyna-Soar glider have been discussed. Because of the design, the pilot can contribute to mission success and will not be adversely affected by the mission profile environments. The attainment of the Dyna-Soar goals cannot be met without man and the price in weight is small compared with the achievement of the Dyna-Soar system objectives.

PROVISIONS FOR PILOT

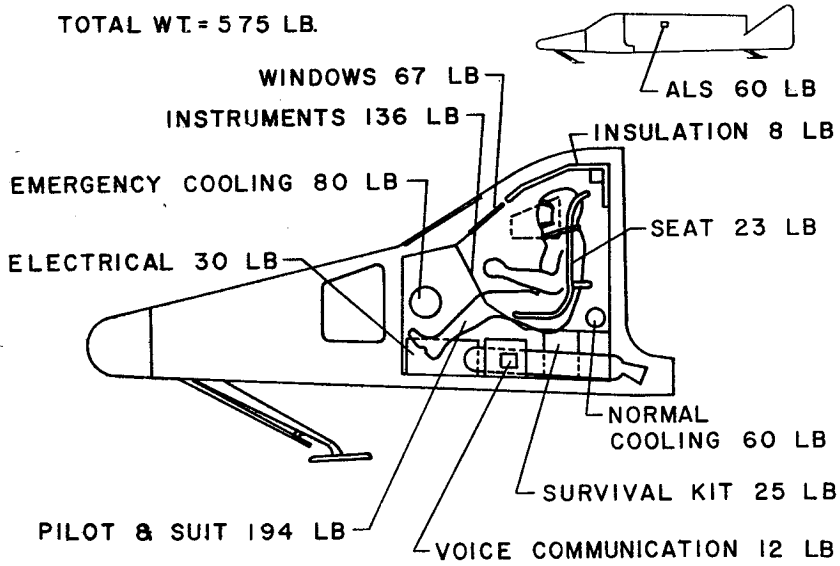

Figure 1

WEIGHT VS SURVIVAL

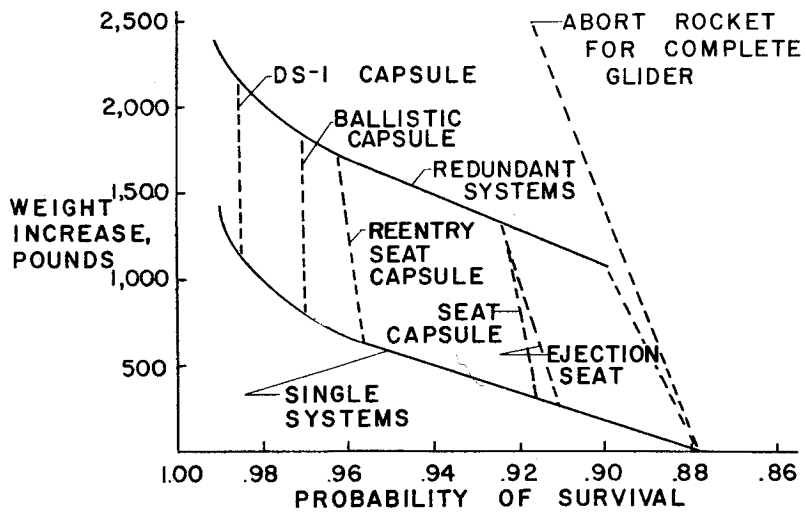

Figure 2



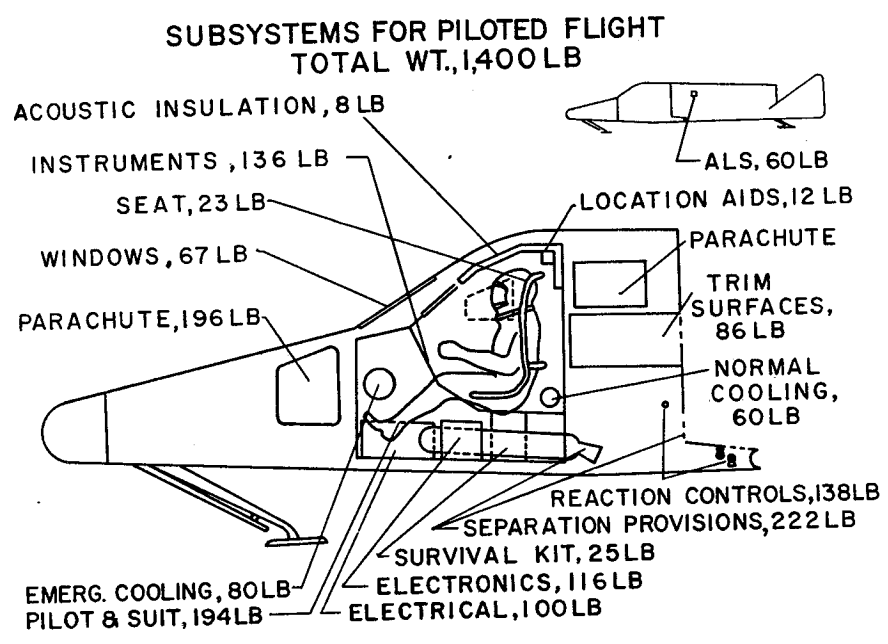

Figure 3

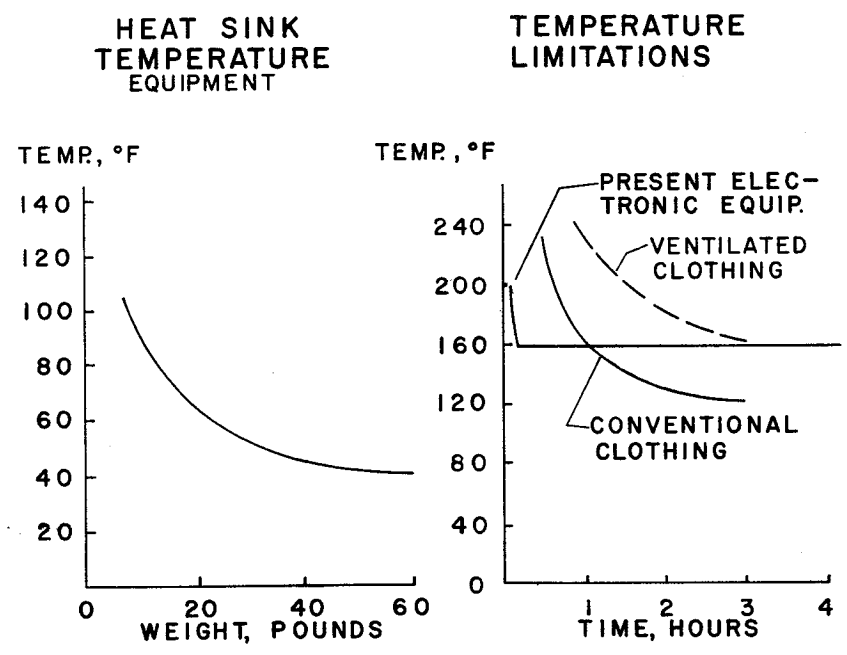

Figure 4

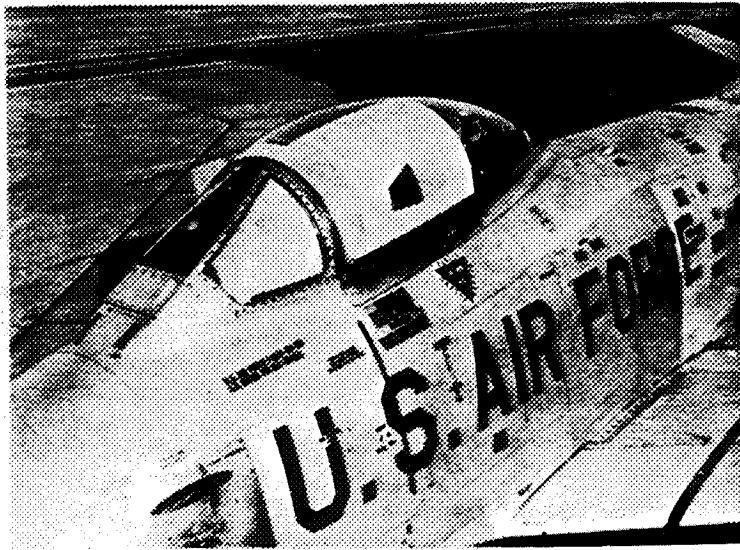

Figure 5

SIDE VISION ON APPROACH

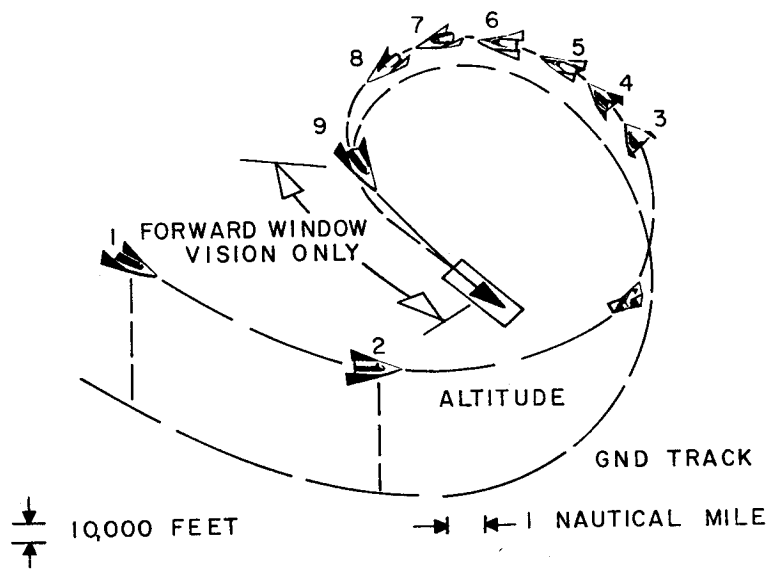

Figure 6

BOOST ACCELERATION

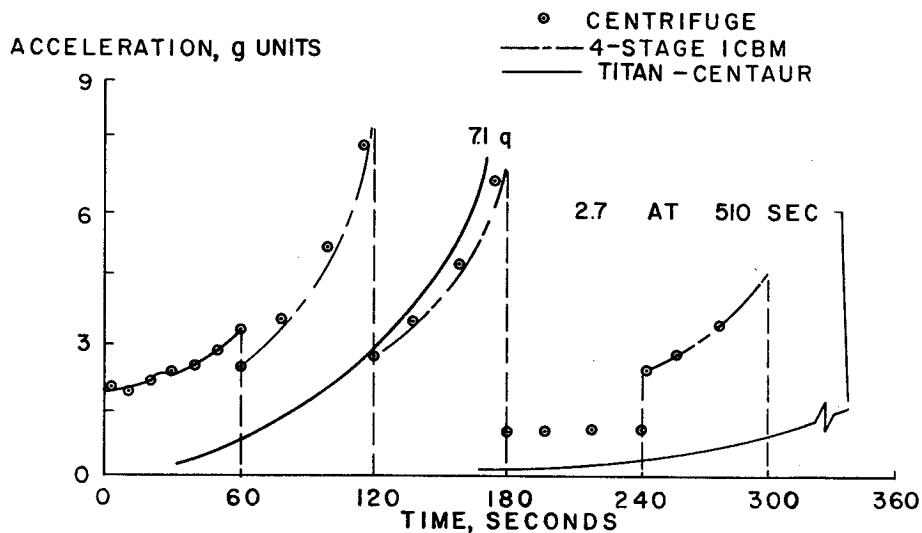

Figure 7

TRACKING EXERCISE

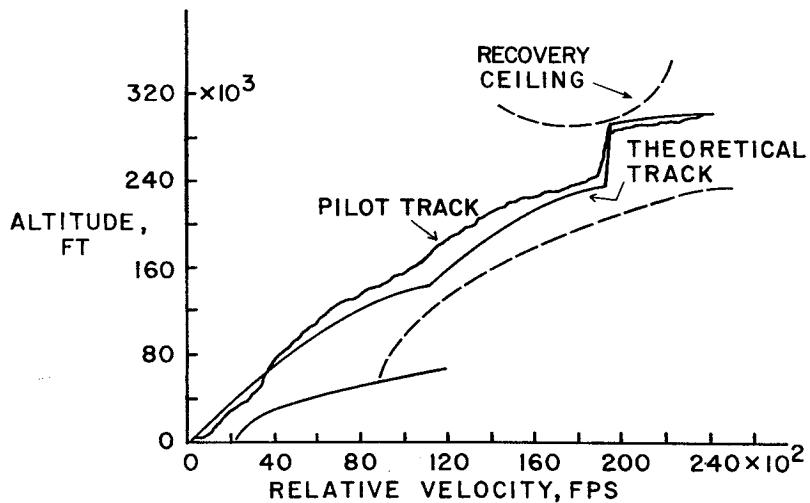

Figure 8

# REACTION CONTROL SIMULATOR

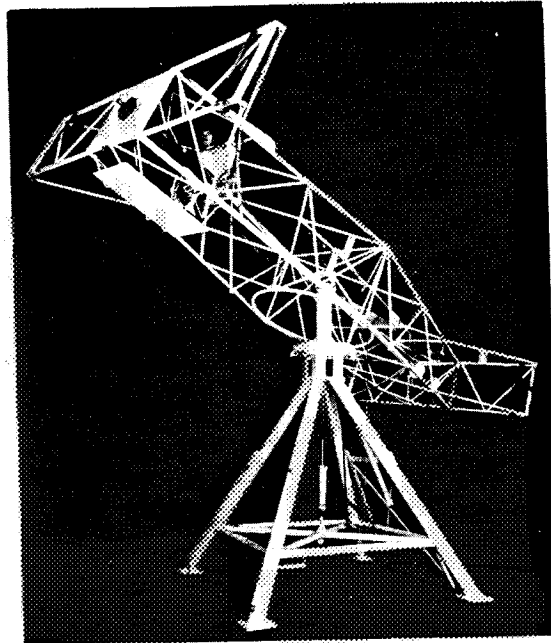

Figure 9

## PILOT'S EFFECT ON MISSION SUCCESS

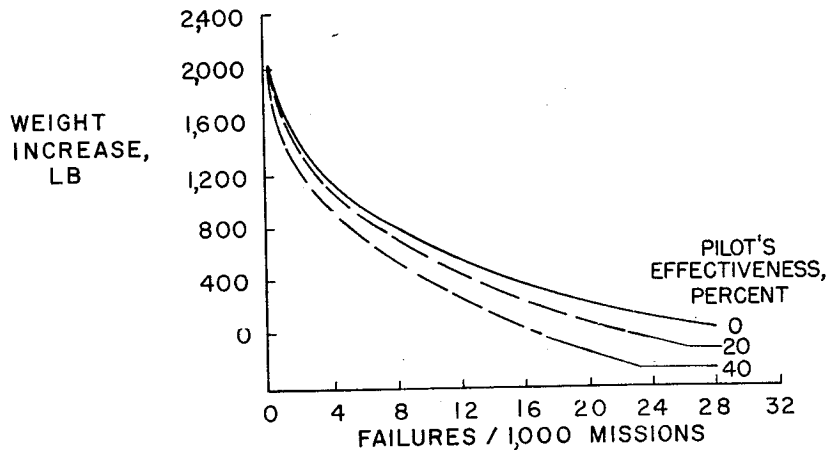

Figure 10