

FATIGUE TESTS ON BIG STRUCTURE ASSEMBLIES OF CONCORDE AIRCRAFT

By V. P. N'Guyen

Société Nationale Industrielle Aérospatiale
Toulouse, France

and

J. P. Perrais

Centre d'Essais Aéronautiques
Toulouse, France

INTRODUCTION

The Concorde, a delta-shaped-wing aircraft, has been submitted to numerous material, attachment and protection tests since, with its structural design, it is capable of reaching supersonic speeds (Mach number, 2.05). In addition, this aircraft has been tested in the scope of structural engineering tests performed on substructures. In this paper, only development tests on large structure assemblies and airworthiness substantiation full-scale tests are considered.

This paper is limited to the tests performed at the Centre d'Essais Aéronautiques of Toulouse (C.E.A.T.), France. The tests carried out in the United Kingdom are to be presented by the Royal Aircraft Establishment (R.A.E.). As a rule, the development tests achieved both in France and in the United Kingdom are usually performed on structures for which Aérospatiale and British Aircraft Corporation are responsible. All certification static tests are to be carried out in France and all certification fatigue tests are to be performed in the United Kingdom.

EXPERIENCE FROM STATIC TESTS

Two main sections have been submitted to pressure, mechanical load, and thermal static tests and are shown in figure 1.

Fuselage Section 1 bis.

The structure, named fuselage section 1 bis. or 1(a), consisted of a 4.68-meter-long twin-looped cylindrical fuselage section including six standard frames and two main frames. On both sides of the lower part of the fuselage, rectangular structural boxes represented the wing assembly and its fuselage junction section. The purpose of this operation was to create the same thermal stresses over this area as those encountered

in flight. The skin panels (A-U2GN sheet) were attached in a classical way to the stringers and frames.

The aim of the tests was to observe the structural behaviour under the most severe flight conditions such as combined pressurization, fuselage torsion and loads on floor, and thermal stresses. Test measurements of temperatures and mechanical strains were also compared with calculated values of thermal stresses in order to (1) justify design methods, (2) make an analysis of the role played by thermal stresses among total stresses (to manage a test program of structures which will be tested in the future), and (3) perfect new test methods, especially in the scope of infrared heating and air-cooling units injecting liquid nitrogen. The tests started at the end of 1964 and ended in the spring of 1966.

This testing enabled the manufacturer to check for the thermal stress level in the fuselage areas hidden by the wing assembly and in the longitudinal stringers located at the bottom of the fuselage. (Fig. 2 shows the results of comparative tests on the heated lower part and the unheated lower part to simulate the presence of a fuel tank.) It was necessary to carry out tests, especially fatigue tests, by representing in a most accurate way thermal stresses where they are significant.

Section 2.8.b

The test structure, section 2.8.b, was composed of a fuselage section (first definition of the aircraft, 10 m \approx 35 ft long) and of main adjacent wing elements having an overall span of 44 ft. (Refer to fig. 1.) This structure is a genuine aircraft element. The purpose of the test was

(1) To check in a more exact way the aircraft design methods. Therefore, the test structure itself with its proposed end effects has been calculated by means of the same network as an aircraft (analog electrical network for internal load computation).

(2) To compare thermal stress distributions obtained from different aircraft missions. These distributions are not easily obtained by computation.

(3) To evaluate fuel influence in the tanks on these thermal stresses.

(4) To study the superimposition of cabin and tank pressure, of air and inertia loads, and thermal effects.

(5) To prove the "fail-safe" characteristics of this structure by making some cuts to simulate cracks in the main spars, ribs, and frames, and then performing residual-strength tests.

(6) To familiarize test laboratories with exceedingly complex installations in order to proceed with the certification static tests on a full-scale aircraft structure (fig. 3) under satisfactory conditions.

These tests commenced in the autumn of 1966 and ended in the summer of 1969. Results are too extensive to be presented in this paper. Therefore, only tests which made it possible to perfect the fatigue test programs are presented.

It was shown by the design calculations that the maximum thermal stress values highly depended upon the aircraft acceleration laws. This dependence was verified when a few wing panels buckled locally during tests simulating missions with high acceleration and low take-off weight. (See fig. 4.) (It was a case of a flight corresponding to a previous definition of the aircraft.) The purely thermal stresses remain moderate in absolute value but are reversed, and their peak-to-peak values are significant. The presence of fuel causes the stresses in heavy parts of spars and ribs to be reduced. On the other hand, the internal skin surface is subjected to tensile thermal stresses when the fuel tank is empty. These tensile stresses add to the internal tensile stresses due to flight loads. The following conclusion may be drawn from this program. For tests on partial structures, great care should be exercised in simulating the temperature distributions over the fuselage internal areas (especially those areas hidden by wing assemblies). (The parasite end effects are very strong.)

Because of the high strength of the fuselage in the presence of large cuts (as required in the FAA fail-safe tests), fatigue tests can be safely conducted by using air to cyclically pressurize the fuselage.

A few "dynamic-cut" tests which were performed on the fuselage throughout frames ended the fail-safe tests; the data from these tests will be used for certification substantiation.

STATIC TESTS FOR AIRWORTHINESS SUBSTANTIATION

The test structure is a full-scale aircraft. The test program consists of a sequence of tests to be performed under room-temperature conditions and including five different tests with loads on a part of the aircraft. All tests were conducted at least up to ultimate design load of the structure and some of them even beyond. The latter sequence of tests will be made under thermal conditions about July 1971 and will start with thermal tests only, during which several aircraft missions will be achieved under realistic conditions. In a first stage, to investigate ovens and cooling problems, C.E.A.T. will use calculated temperatures which are being verified by means of flight measurements on the prototype. The test temperatures will be submitted to the Airworthiness Authorities for approval. Figures 5 and 6 illustrate different static-test sequences.

FATIGUE TESTS

These tests have been performed on many structural components, but the test programs achieved by use of big substructures 2.3.2 and 2.6/2.7 (fig. 1) are by far the most significant.

Preliminary static tests showed that it was necessary to reproduce the temperature distributions during acceleration and deceleration sequences. When the fatigue test programs were initiated, it was found that this operation would require a test of long duration; the time cycle in the laboratory was almost equal to the time required for an actual flight. It was absolutely necessary to compromise some part of the test program in order to obtain some desired results for the structural behaviour within a reasonable period of time.

Two changes were made in the test program to compensate for accelerating the thermal tests: (1) To compensate for creep, normal structural temperature has been increased by 20°C (from 100°C to 120°C), (2) To compensate for deteriorations due to thermal stresses, the heating rate $d\theta/dt$ has been increased during acceleration and deceleration sequences in order to increase the stresses by 15 to 20 percent, depending upon particular components.

In order to accelerate testing, the time during which the external wall temperatures were constant was decreased. Figure 7 shows that this decrease was feasible since (a) the same maximum temperatures were achieved as in actual flight for both external wall and internal structure, (b) the wall and structure returned to room temperature at the end of the programmed time cycle, and (c) the heating sequence during the time of constant temperature produced satisfactory thermal gradients during the deceleration sequence.

On the test section 2.3.2, this requirement was met by blowing hot or cold air onto fuselage areas hidden by the wing assembly. On test section 2.6/2.7, the same result was obtained by injecting hot and cold liquid into the fuel tanks, as required. These procedures are called "complementary means."

Determination of Cycle

Random maneuver and gust loads were applied by lever jigs. For these development tests to be performed, it was preferable to reduce the typical loading spectrum to its simplest terms to investigate more easily the possible crack propagation rates. Pressure loads, since they are actually known, have been used at their flight true values; that is, $p = 736\text{ mb}$ inside the cabin compartment, and $p = 250\text{ mb}$ inside the fuel tanks. Thermal stresses were increased 10 to 20 percent, depending upon the area, to accelerate

the observance of the deteriorations due to thermal stresses. By using this increase, an attempt was made to double the damage value due to thermal stresses.

Three mechanical and three pressure cycles were superposed on each thermal stress cycle. In one instance (A), the mechanical and the pressure cycles were applied simultaneously while the thermal stresses were high. In two other instances (2B), the mechanical and pressure cycles were applied simultaneously while the thermal stresses were small or nil (corresponding to a slow return to room temperature). This sequence of loading produced a threefold increase in damage due to the usual loads. Cycles $C = A + 2B$ are performed one after the other.

Final Test Conditions

Final test conditions were based on and perfected from typical tests. During these typical tests, the actual flight real time requirements were met in order to accurately determine the required heating rates and thermal stresses during a flight. Based on the results of these typical tests, several short time cycles were tested and complementary means were used to obtain the desired temperature and stress evolution (especially peak-to-peak) at all significant measurement points. The complete time cycle of test 2.3.2 is shown in figure 8; whereas the complete time cycle of test 2.6/2.7 is shown in figure 9. It is easily noticed that with 1 hour's cycle (of which 40 minutes is thermal) for 2.6/2.7 tests and that with a 34 minutes' cycle (of which 26 minutes is thermal) twice the thermal damage and three times the mechanical damage of a 3 hr 15 min flight is produced.

Results Obtained on Test Structure 2.6/2.7

By March 10, 1971, 9900 cycles (A + 2B) and 10 900 additional B cycles (representing purely subsonic flights) were applied. This stress history corresponds to the damage caused by 40 600 flights under mechanical fatigue conditions and about 19 800 flights under thermal fatigue conditions. The deteriorations that were noticed occurred on the (current) fuselage frames at the level of the cabin floor. They were due to a combination of pressurization and thermal cycles. As a result of these deteriorations, design improvements were made on partial assemblies representing the damaged area (fig. 10). In tests on these partial assemblies, a special fixture was used to simulate the frame warping due to thermal stresses. The results of these tests were very satisfactory, and enabled an excellent behaviour of the frames to be foreseen on series aircraft.

Results Obtained on Test Structure 2.3.2

By March 1, 1971, 14 000 complete cycles (A + 2B) and 4000 purely subsonic flights were applied. This stress history corresponds to the damage caused by 46 000 flights under mechanical fatigue conditions and about 28 000 flights under thermal fatigue conditions. The deteriorations that were noticed confirm those which were obtained with the substructure 2.6/2.7, and indicated that the same design improvements were required. Some minor deteriorations were found in the door and emergency exit locking devices. These deteriorations very likely come from local bending effects due to thermal stresses, and to defects in the door. A few cracks on metal sheets were detected and the investigation of the crack propagation rate is being made. Inside the wing fuel tanks, the original rods fitted with clevis welded by an electron bombardment process did not have a suitable fatigue life and have been replaced by conventional design rods.

Residual Strength After Deteriorations

Deteriorations, especially those concerning fuselage frames, were always found during the systematic inspection of the structures, that is, following completion of a program block including 1000 cycles (A + 2B). The damaged structure exhibited satisfactory residual strength during the last cycles of the program block.

A flight limit load test upon occurrence of deteriorations has just been made on structure 2.6/2.7; this test will be used for certification purposes. Figures 11 and 12 illustrate the test rigs 2.3.2 and 2.6/2.7.

CONCLUSIONS FROM DEVELOPMENT TESTS

The main conclusions are as follows:

1. On a supersonic aircraft whose structure weight is a significant part of the weight analysis, many fatigue and static strength development tests should be made.
2. Fatigue thermal tests are absolutely necessary. Temperature and thermal stress calculations, although they are very developed, cannot foresee any fatigue failures caused by distortion incompatibilities which are not easily evaluated.

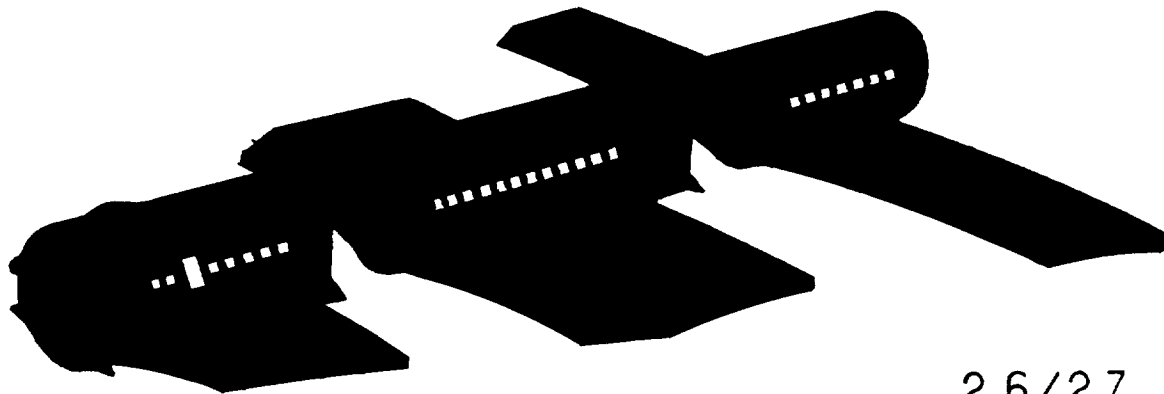

2.3.2
FATIGUE TEST

2.8. b
STATIC TEST

2.6/2.7
FATIGUE TEST

FRENCH TEST SUBSTRUCTURES FOR
CONCORDE DEVELOPMENT TESTS

Figure 1.

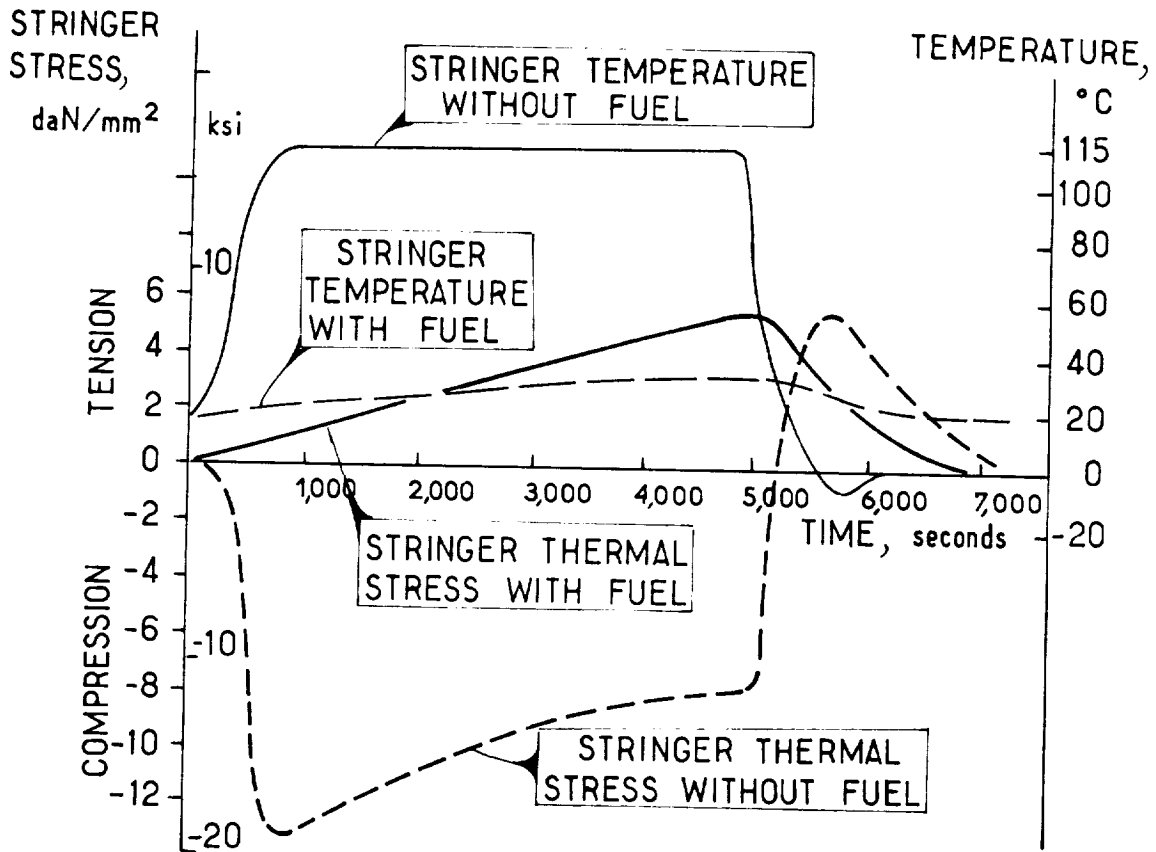

STRUCTURE 1 bis -EFFECT OF THE FUEL ON LONGITUDINAL THERMAL STRESSES ON A BOTTOM STRINGER OF A FUSELAGE FUEL TANK

Figure 2.

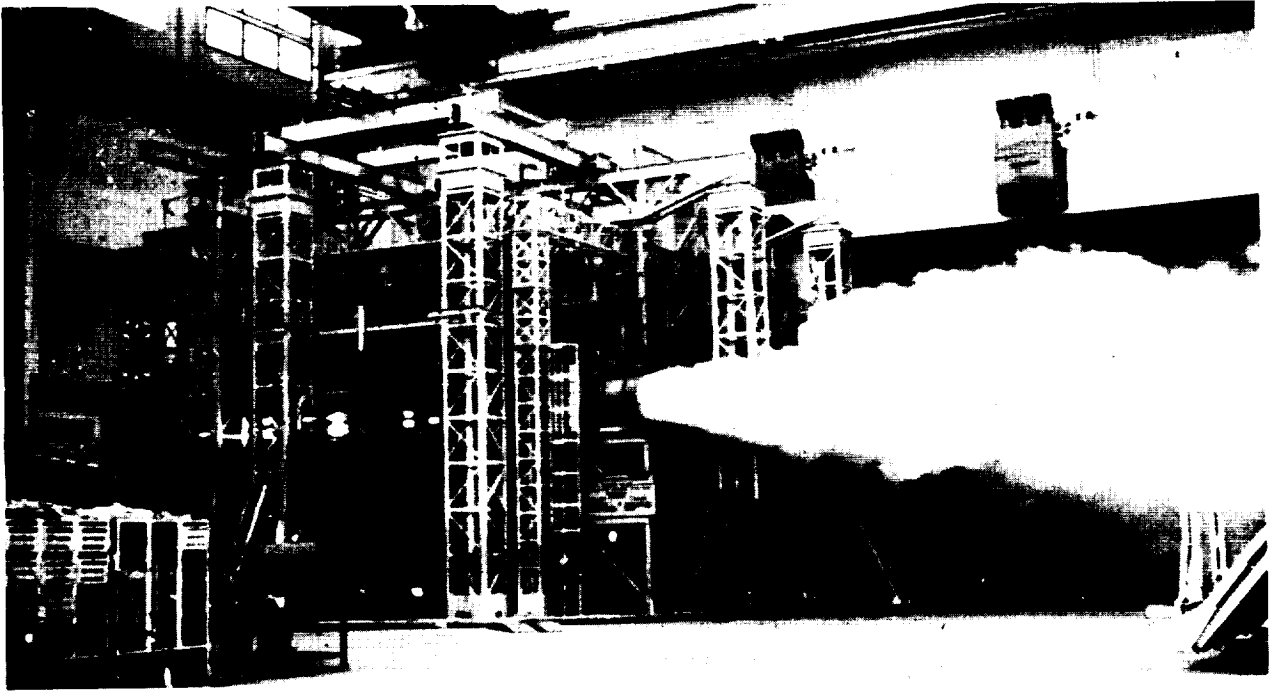

2.8.b THERMAL TEST - COOLING BY LIQUID NITROGEN

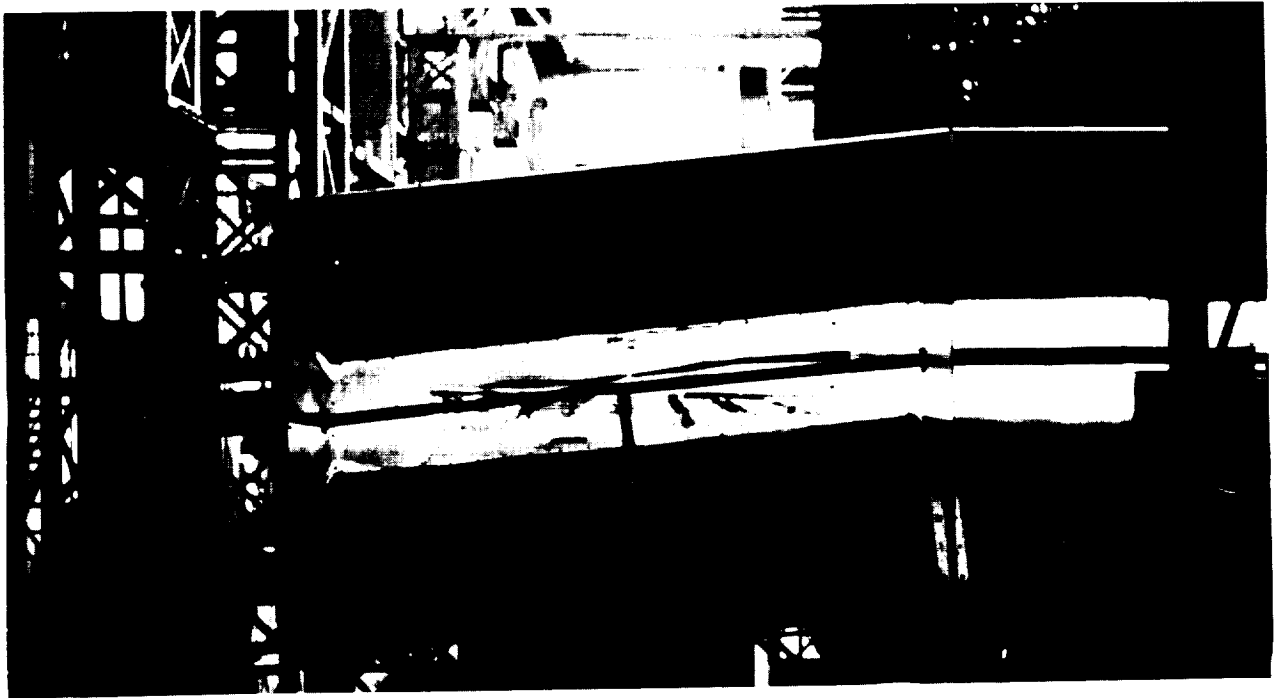

2.8.b THERMAL TEST - WING OVENS

Figure 3.

TEMPERATURE, θ , °C

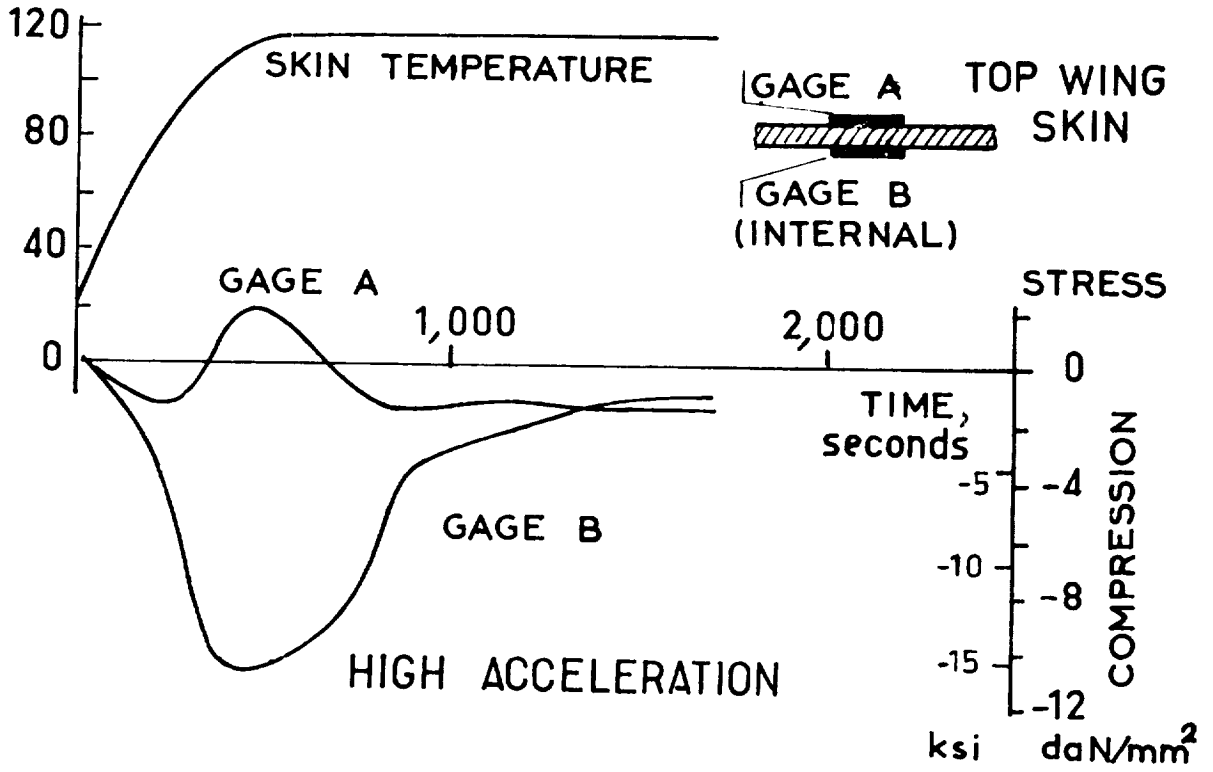

TEMPERATURE, θ , °C

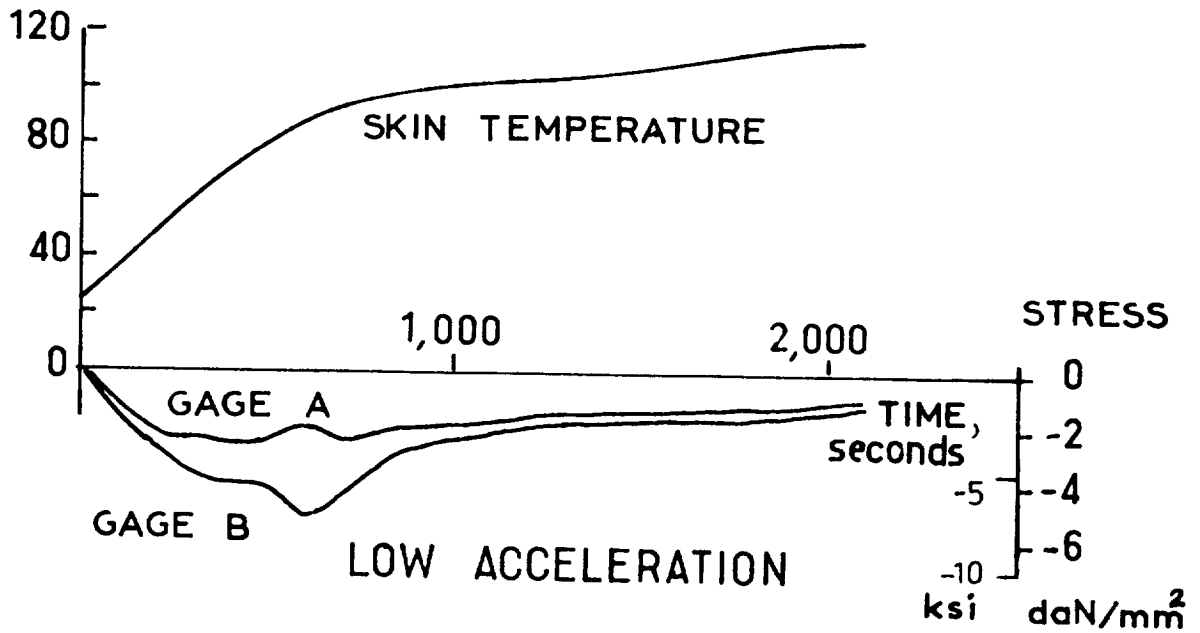

2.8.b STRUCTURE - THERMAL TESTS.

Figure 4.

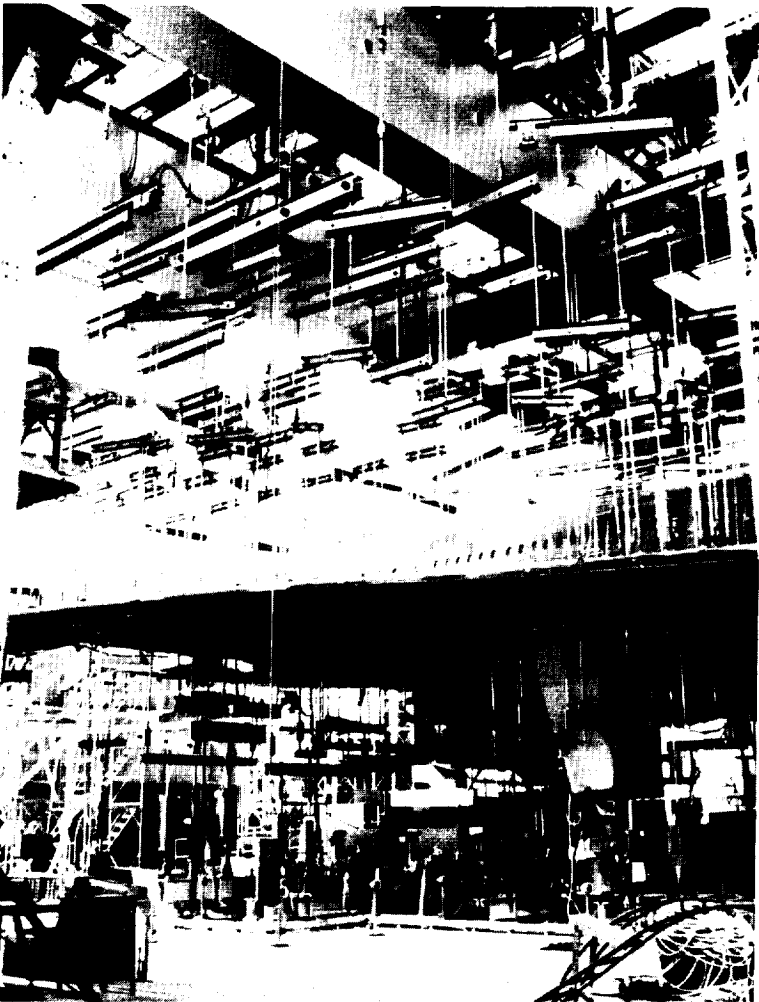
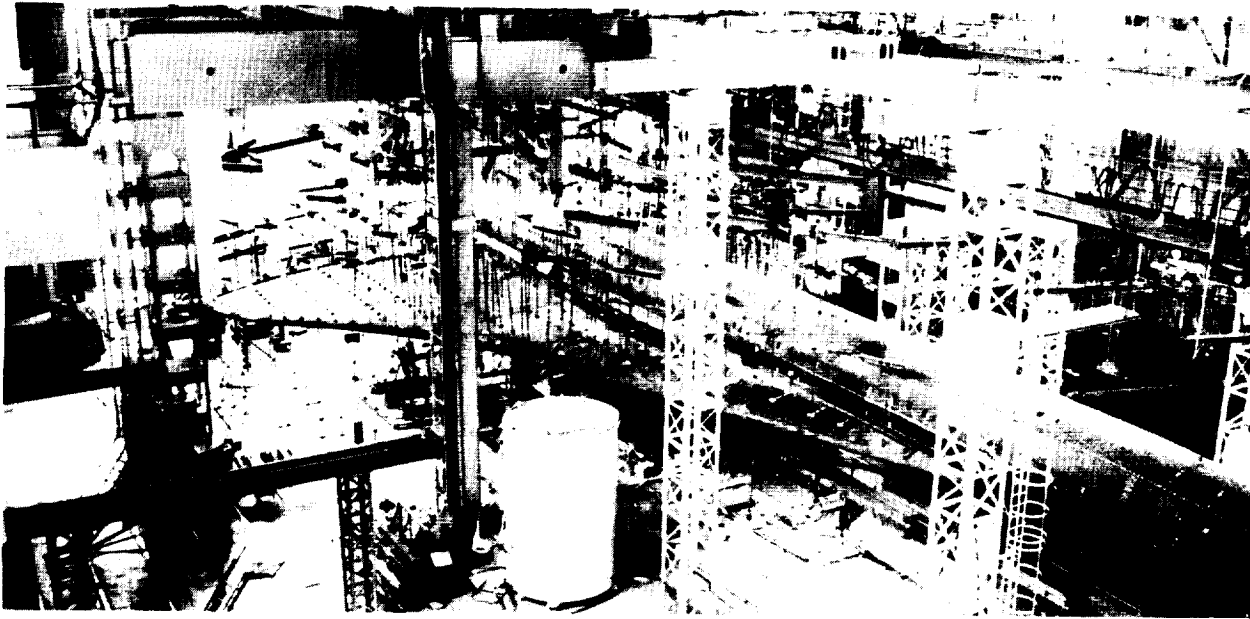

MAJOR STATIC TEST-
GENERAL VIEWS.

Figure 5.

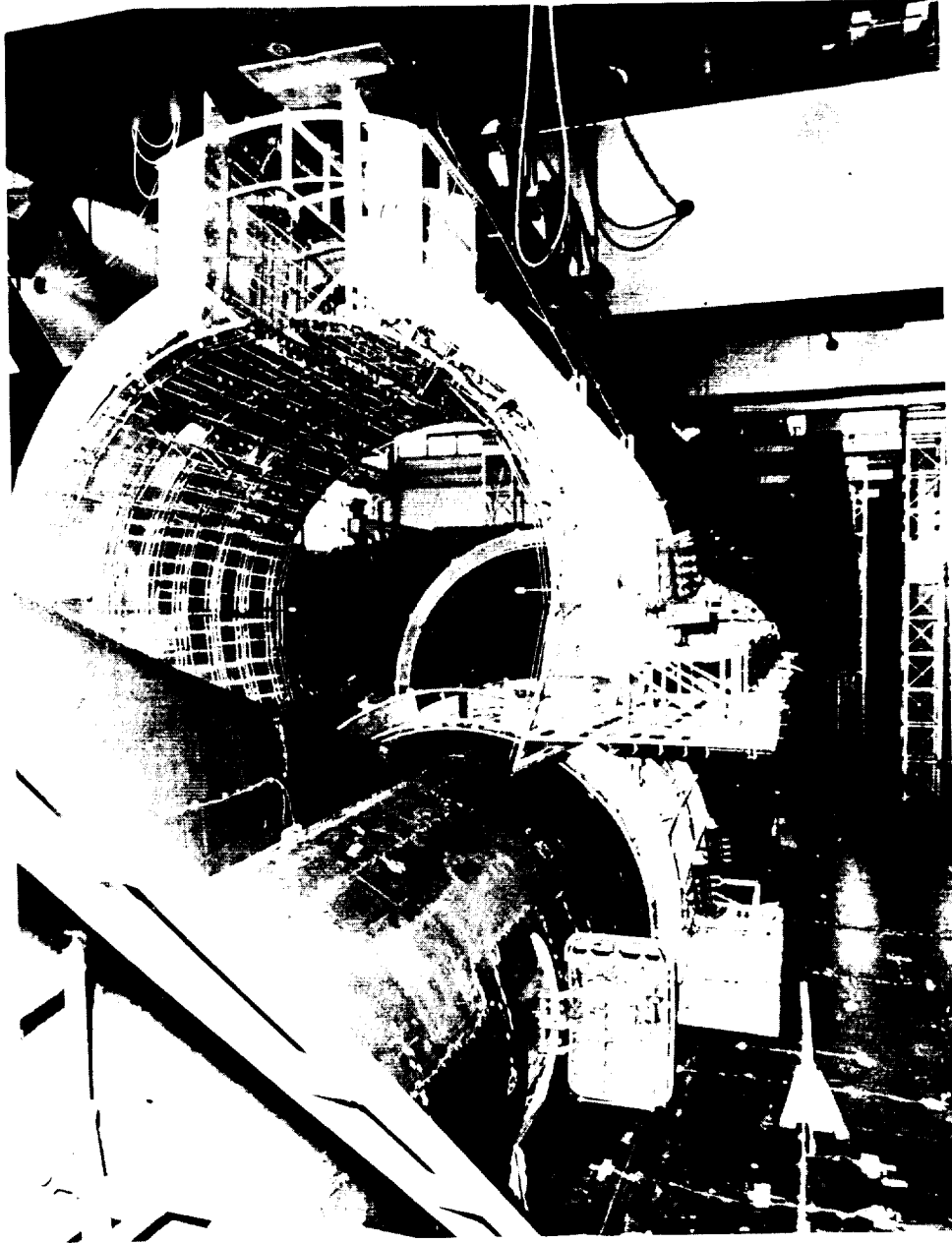

THERMAL STATIC TEST.

INFRA-RED OVENS ARE BEING INSTALLED AROUND
THE FUSELAGE.

Figure 6.

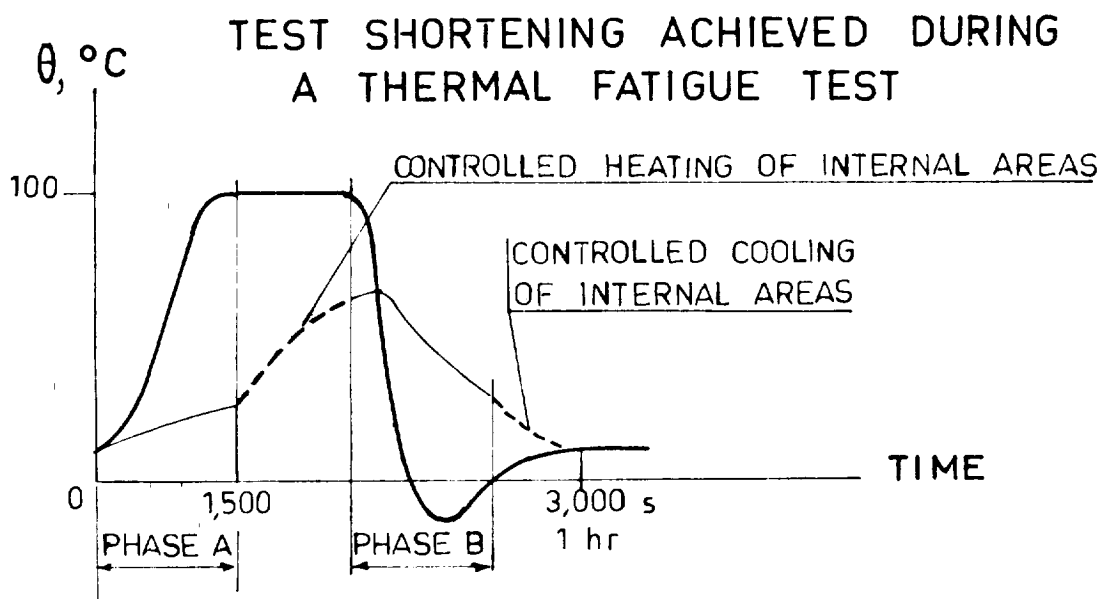
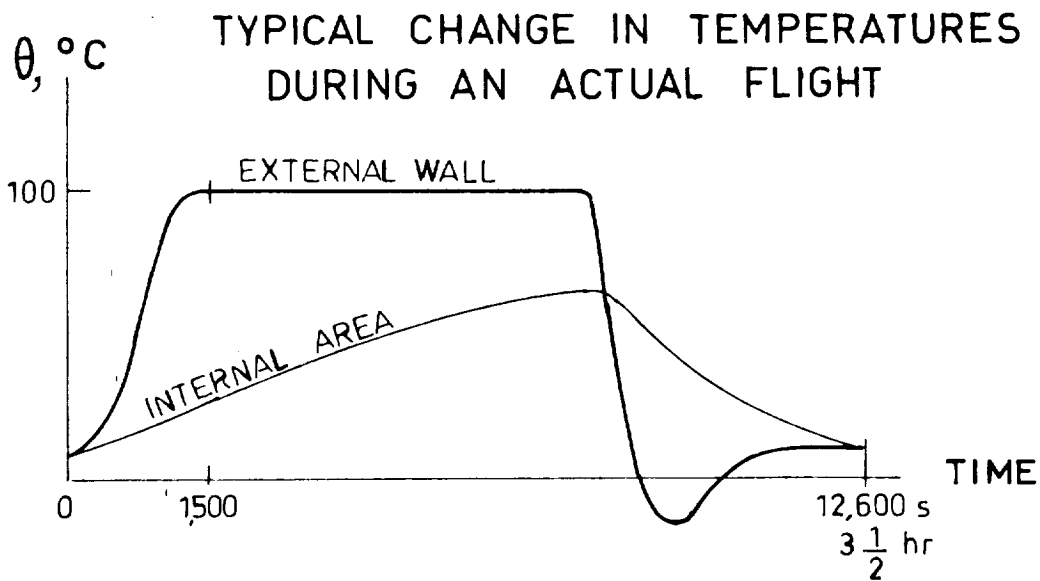

FOR A AND B PHASES THE TEMPERATURES
CHANGE AS IN THE ACTUAL FLIGHT.

THE PRINCIPLE USED TO SHORTEN
THE THERMAL CYCLE DURATION

Figure 7.

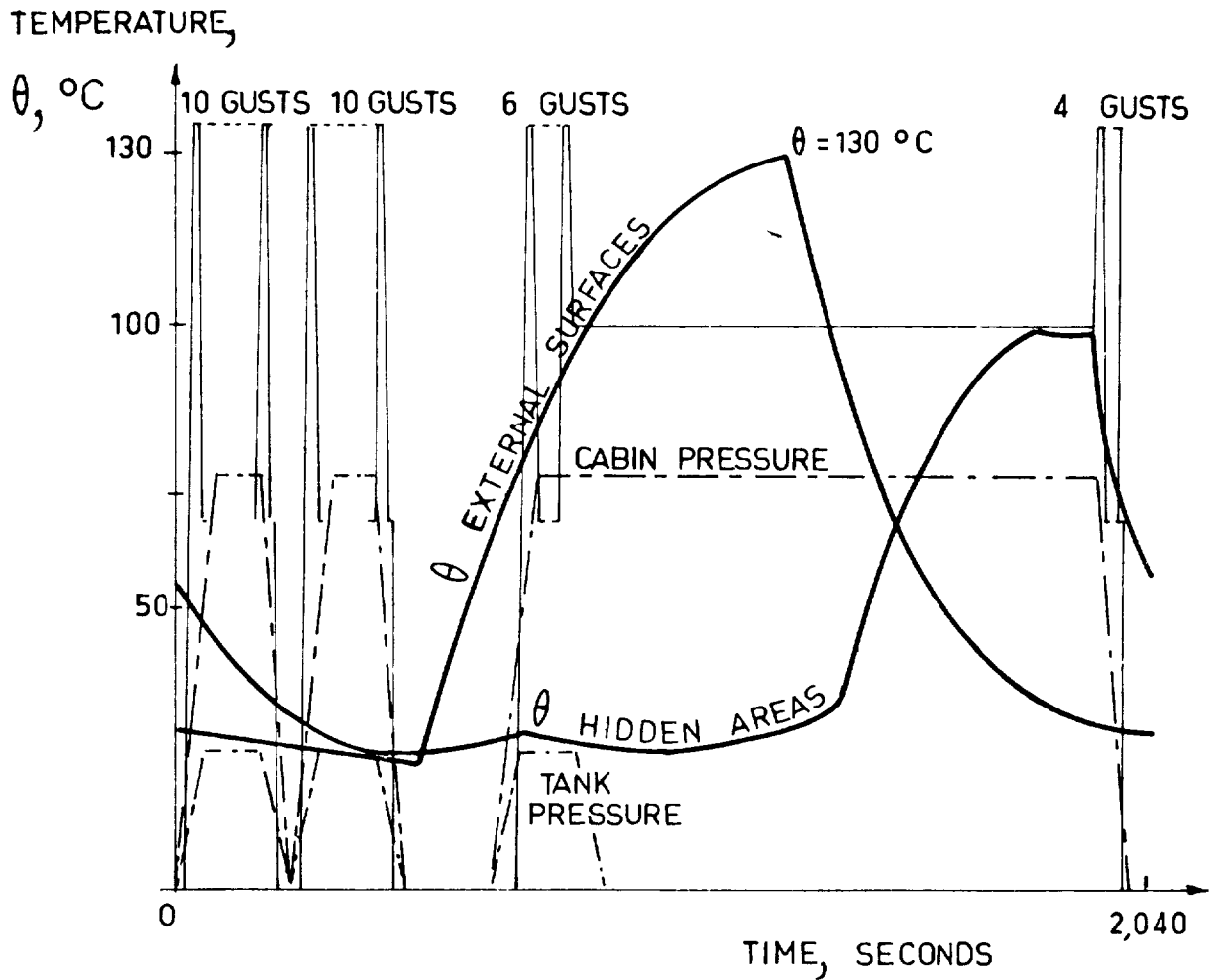

NOTE : GUST LOADS AND PRESSURE LOADS ARE NOT SCHEDULED IN THIS PLATE.

TEMPERATURE AND FATIGUE CYCLE OF THE CONCORDE 2.3.2 DEVELOPMENT FATIGUE TEST.

Figure 8.

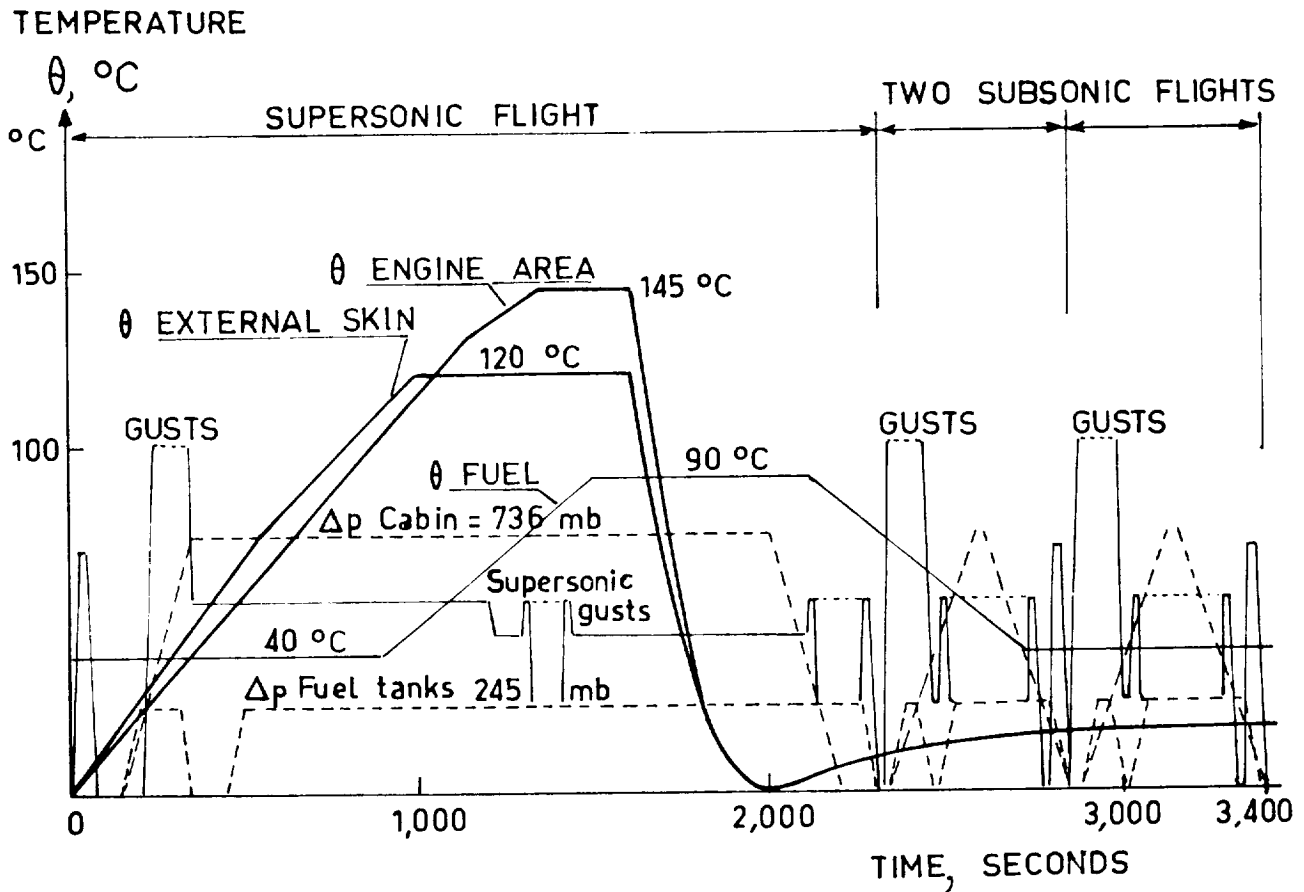

2.6/2.7 CONCORDE TEST STRUCTURE -
 TEMPERATURE AND FATIGUE CYCLE.

Figure 9.

NOTE: THE LOAD L WAS DETERMINED TO OBTAIN BETWEEN B- AND E- SECTIONS THE STRESS DISTRIBUTIONS THAT WERE MEASURED ON FRAMES OF THE 2.6/ 2.7 STRUCTURE DURING THERMAL AND MECHANICAL FATIGUE TEST.

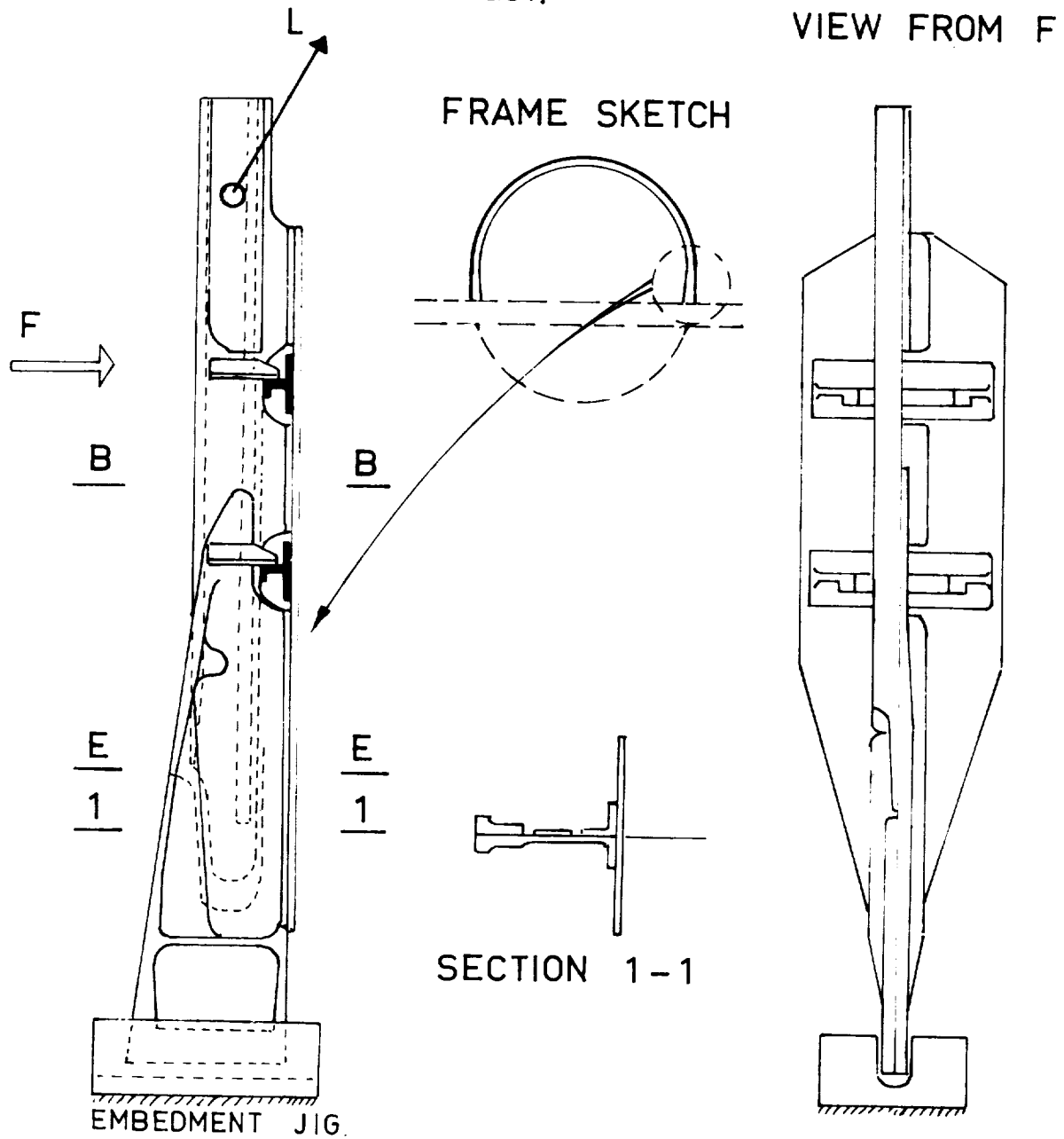

DEVELOPMENT SPECIMEN TO APPRAISE IN A SHORT TIME IMPROVEMENTS OF THE FUSELAGE FRAME DESIGN.

Figure 10.

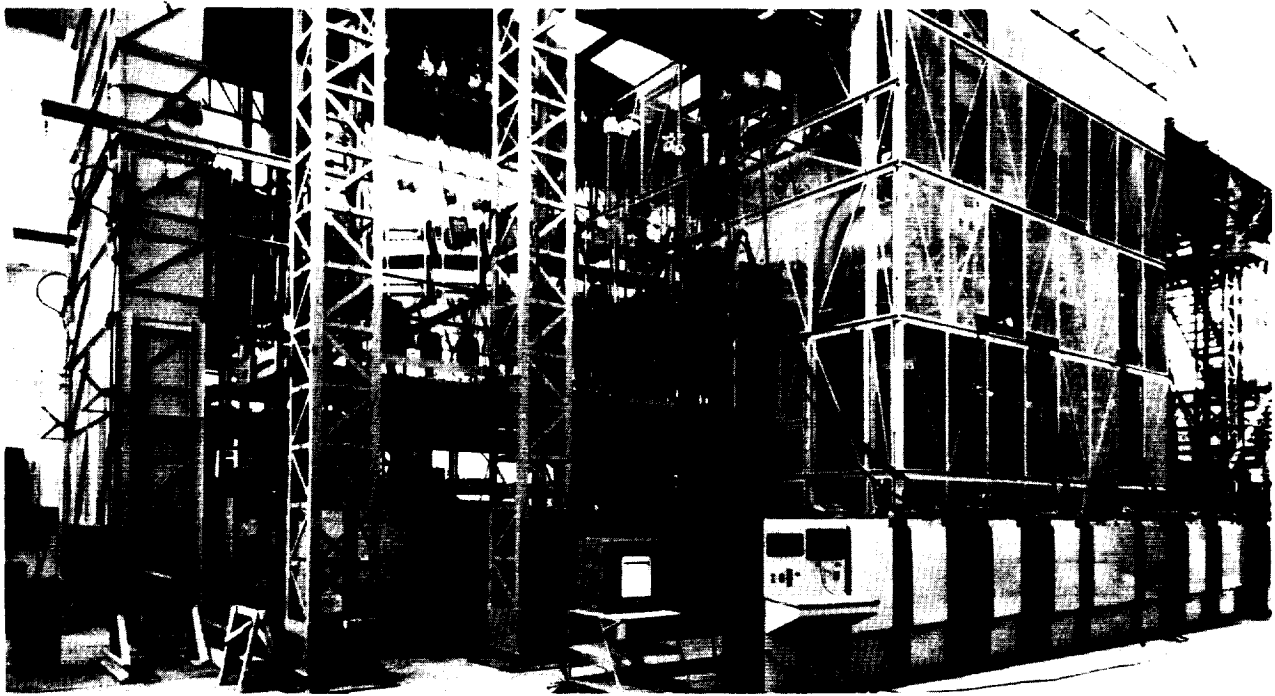

GENERAL VIEW OF THE 2.6/2.7 TEST RIG.

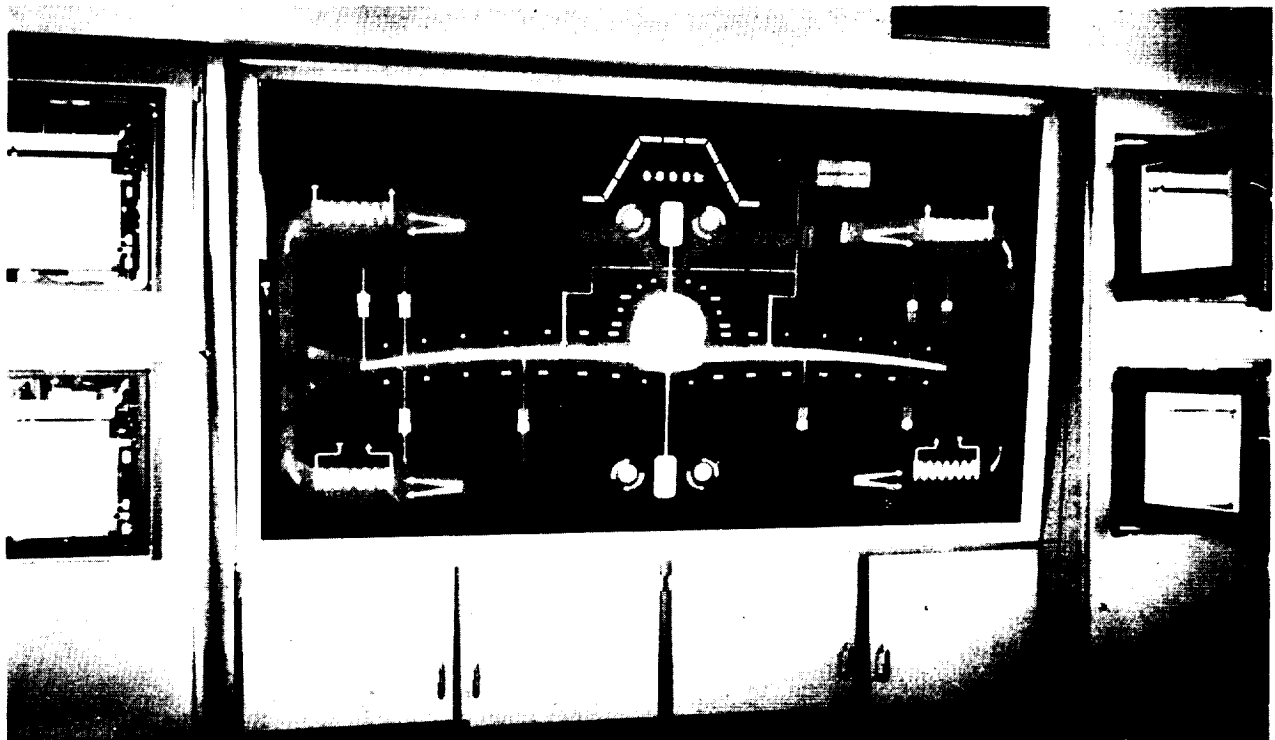

CONTROL ROOM OF THE 2.6/2.7 FATIGUE TEST.

Figure 11.

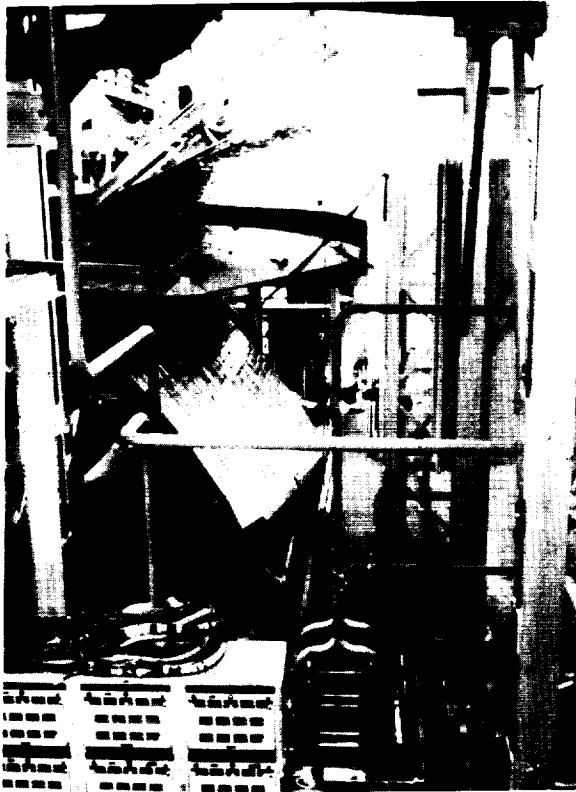

2.3.2 FATIGUE TEST RIG.

THE WING PART IS VISIBLE
BETWEEN TOP AND BOTTOM
WALLS OF THE OPEN OVEN.



GENERAL VIEW OF THE 2.3.2 FATIGUE TEST RIG.

Figure 12.