

# ADVANCED DOSIMETRY SYSTEMS FOR THE SPACE TRANSPORT AND SPACE STATION

MAJOR LOUIS F. WAILLY  
U S Air Force Academy

CAPT MARION F. SCHNEIDER  
Air Force Weapons Laboratory

DR. BENTON C. CLARK  
Martin Marietta Corporation  
Denver, Colorado

Instrumentation to measure the operationally significant high energy radiations encountered in future manned spaceflight is of fundamental importance in ensuring astronaut safety, system survivability, and ultimate mission success. This paper describes advanced dosimetry systems concepts that will provide automated and instantaneous measurement of dose and particle spectra. Proposed are systems to measure dose rate from cosmic radiation background to >3600 rads/hour. Charged particle spectrometers, both internal and external to the spacecraft, to determine the mixed field energy spectra and particle fluxes for both real time on-board and ground based computer evaluation of the radiation hazard are described.

New and advanced automated passive dosimetry systems consisting of thermoluminescent dosimeters and activation techniques are proposed for recording the dose levels for twelve or more crewmembers. This system will allow automatic on-board readout and data storage of the accumulated dose and can be transmitted to ground after readout or data records recovered with each crew rotation.

The United States Space Station/Space Shuttle Program to be flown in the late 1970's and early 1980's will be constrained to operate in the hostile energetic radiation environments surrounding and constantly impinging on near earth space. The very high energies of many of these radiations and the relatively thin shielding of the Space Station/Space Shuttle will expose crews, critical biological and electronic experiments and systems to a constant bombardment of charged and neutral particles, and X-rays. The real time and time historical profiles of these radiations must be monitored on-board all spacecraft. Special problems are associated with the monitoring of space radiations that prohibit the use of presently available ground based systems. The space hardware must measure a much wider range of energies and particle types in operational situations that would never be demanded of an earth based system. This dictates that the hardware be highly complex, yet due to weight, power, volume, and recording and readout limitations imposed by spaceflight, many additional constraints will be associated with the space radiation monitoring instrumentation. In addition, space hardware must be specifically hardened to environmental specifications not usually considered in earth based operations. In this report are described a unique family of active and passive radiation sensors and electronics that will adequately monitor the radiation threat to Space Station and Space Shuttle crews and on-board systems. All instruments described in this report can be fabricated from existing state of the art radiation detection technology.

SUMMARY OF EXPECTED RADIATION ENVIRONMENTS AT SPACE STATION/SPACE SHUTTLE OPERATING ORBITS

The Space Station/Space Shuttle flights will encounter two general types of radiations that will be of dosimetric and spectroscopic concern to their operations. Classed according to origin these are:

- 1) Naturally Occurring Radiations
- 2) Manmade Radiations

The naturally occurring radiations of operational interest are 1) the trapped electrons and protons of the Van Allen Belts; 2) energetic solar flare protons and alpha particles; and 3) protons, alpha particles, and multicharged heavy nuclei of galactic cosmic rays. The general geophysical characteristics of these radiations are well known (Ref. 1 through 11). The naturally occurring Van Allen Belt electrons have been measured with energies from a few kev to over 4.5 Mev. Protons of the Inner Van Allen Belt are observed to extend from below 10 Mev to over 600 Mev. Solar flare particles reach near earth space with energies from a few Mev to well over a Bev, depending on the nature of the accelerating mechanisms on the sun. Solar flare particle events are as of this writing unpredictable and are considered by many as the greatest hazard to manned spaceflight operations in near earth space. Cosmic rays range from below 0.1 Bev to over  $10^{11}$  Bev. For the energy range of 500 Mev to 20 Bev, cosmic ray protons have been observed to follow the spectral law:

$$J(E) = \frac{0.3}{1 + E^{1.5}} \frac{\text{particles}}{\text{Cm}^2 - \text{Sec.}}$$

(Ref. 13).

The manmade radiations encountered in spaceflight are: 1) the artificial fission spectrum

trapped electrons of the Inner Van Allen Belt, 2) potential nuclear reactor sources associated with the Space Shuttle and Space Transport, and 3) other on-board radioactive sources required to operate spacecraft and on-board experimental systems. The current fluxes of electrons in the earth's artificial radiation belts were created in 1962 by United States and Soviet high altitude nuclear weapons detonations that produced high fluxes of trapped fission spectrum electrons, (Ref. 14). These were superimposed on the natural electrons already present in the Van Allen Belts in 1962. A typical series of artificial electron spectra of the Van Allen Belts are shown in Figure 1 (Ref. 14). The flux levels of artificially injected electrons in the earth's radiation belts are subject to constant decay (Ref. 15) and at this writing have become comparable to the natural electron fluxes. If no further electrons are artificially injected into the radiation belts, by the time that the Space Shuttle is flown, these so called "Starfish Radiations" will be of little concern to operations. However, Figure 2 (Ref. 16) predicts that the flux levels at 400 Km from a nuclear weapon of 4 Megatons will be at least  $10^8$  electrons/Cm<sup>2</sup>-Sec. ( $1.0 < E < 2.0$  Mev). With electron fluxes of this magnitude possible, hardware designed for the Space Station/Space Shuttle must include contingency procedures to measure artificial electron fluxes of this nature in the event of hostile action. It is uncertain at this time if nuclear reactors will be flown on the Space Station or Space Shuttle. In the event that they are flown, specific sensors to monitor the neutron and gamma components of reactors must be developed. High neutron fluxes such as produced by reactor operations are not ordinarily encountered in spaceflight. The intensity of neutrons produced in the earth's albedo, in the spacecraft mass, or directly from the sun are negligible compared to the primary charged particle radiations or to the neutron fluxes that would be produced in a spaceborne reactor. The flight of a nuclear reactor in

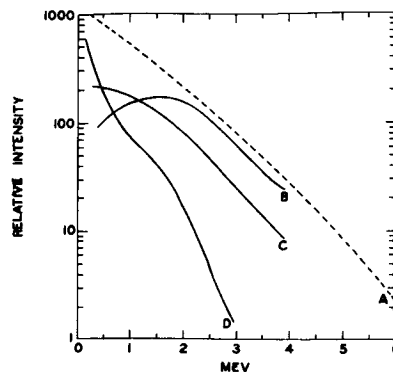

Figure 1. Selected Electron Energy Spectra for the Starfish Electrons. Curve A is the Equilibrium-Fission Spectrum, Curve B is Measured at L= 1.25, Curve C is Measured at L= 1.34, and Curve D is Measured at L= 1.57. All Measurements Dec. 1962.

conjunction with any future manned space mission would increase the radiation exposure as well as result in the need for a larger array of radiation monitoring instruments. The type and number of on-board radiation sources that may be used on the Space Platform and associated flights cannot be accurately determined at this early date, however, if we take the present Apollo and Skylab Programs as representative spaceflights, there are many beta and gamma emitters that the crew could come into contact with. In most cases though, the on-board sources on either of these present space programs are of very low energy or activity or are located at a great enough distance or behind sufficient shielding that they provide negligible doses to the crew or other critical systems. The types of on-board sources flown to date can easily be monitored by instruments already designed to measure the natural space radiations.

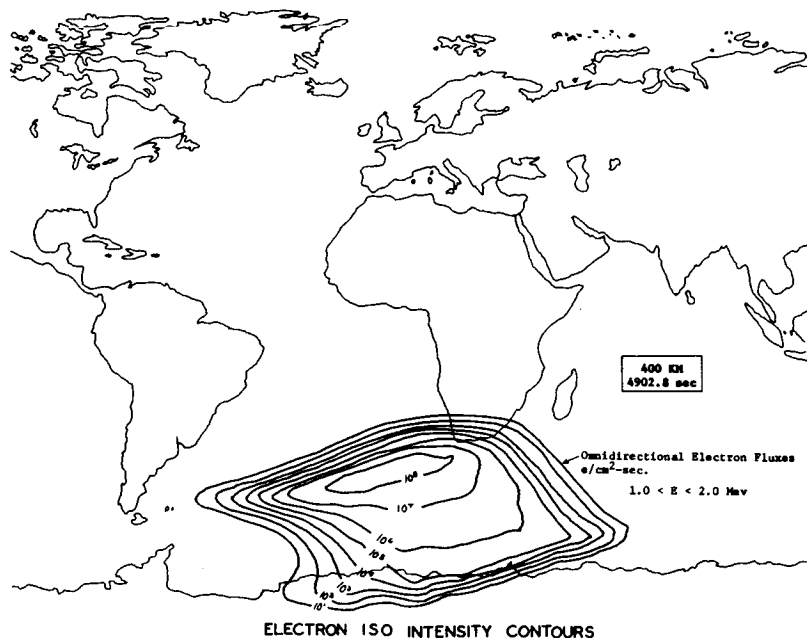

Figure 2. Predicted Artificial Electron Fluxes in the South Atlantic Anomaly.

The expected dose levels from the natural and manmade trapped radiations in the Van Allen Belts has been calculated, (Ref 17) for selected orbital altitudes and inclinations using different possible shields from 0.0001 grams/cm<sup>2</sup> to 10 grams/cm<sup>2</sup>. Table 1 summarizes these calculations.

TABLE 1

Dose Calculations for Selected Shielding Depths (g/cm<sup>2</sup> aluminum) and Various Orbital Parameters for the Space Platform, Doses in Rad/day.

Orbital Parameters		Shielding Thickness (Uniform Cylindrical)					
Altitude	Inclination	.0001	0.4	1.0	2.0	5.0	10.0 (g/cm <sup>2</sup> )
320 Km.	55°	3 x 10 <sup>5</sup>	3.30	.65	.13	.022	.006
320	70°	2.5 x 10 <sup>5</sup>	2.72	.53	.10	.017	.0045
320	90°	2 x 10 <sup>5</sup>	2.47	.47	.086	.015	.004
480	55°	10 <sup>6</sup>	2.02	3.94	.74	.17	.09
480	70°	10 <sup>6</sup>	16.7	3.10	.57	.13	.07
480	90°	10 <sup>6</sup>	14.3	2.70	.51	.12	.067

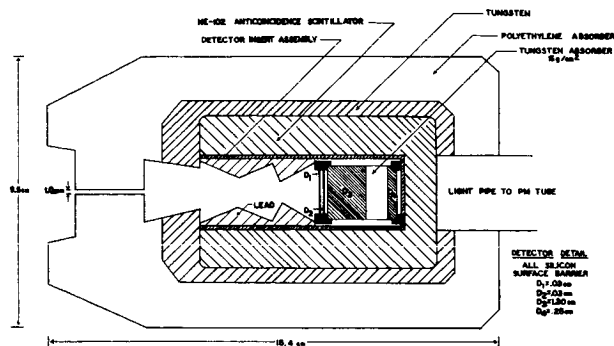

ELECTRON, PROTON, ALPHA, AND MULTICHARGED PARTICLE DIRECTIONAL SPECTROMETER TELESCOPE

Figure 3.

### SPACE RADIATION MONITORING SYSTEMS

Instruments described in this report are classified as either external or internal to the Space Platform. The external sensors measure the flux and spectra of energetic electrons, protons alpha particles, and higher Z multicharged particles. Both directional and omnidirectional detectors are required to define the physical characteristics of space radiations. The second group of instruments proposed are internal to the space vehicle. They measure both dose and particle energy plus linear energy transfer spectra. This class of instruments are in some cases mounted in the spacecraft, or may be when required worn on the astronauts' person for monitoring internal or external to the spacecraft.

#### Directional and Omnidirectional Charged Particle Spectrometers

It is possible with recent advances in micro and integrated circuitry to combine both directional electron and proton measurements into a single system. We have flown and examined the results of many other charged particle spectrometers designed since 1961. Based on performance in flight of the various instruments, the use of multidetector solid state sensors provides the most accurate and reliable Space Platform directional electron and proton measurements. We propose the use of the multiple charged particle telescope arrangement shown in Figure 3, to conduct directional measurements of charged particles both in the Van Allen Belts and from solar flare particles. This telescope assembly was modified by the authors from an original solid state space radiation monitoring system developed by Ref. 18. Extensive changes in detector design were performed by the authors following flights of the instrument on unmanned Air Force Van Allen Belt satellites over the past several years. These include new state of the art, solid state detectors, the inclusion of an additional antineutrino scintillator to prevent unwanted particles

from entering the sides and back of the detectors, and the replacement of the original beryllium electron collimator with polyethylene which is more suitable for manned spaceflight. The electronics of this system have been completely revised to include the best available energy discriminators, low noise power conversion system, and signal conditioning amplifiers. The electronic block diagram for this system is shown in Figure 4. This solid state system is designed to achieve a high level of refinement in particle type and energy analysis, a narrow angular acceptance cone (less than 6°), and excellent time resolution. This provides outstanding charged particle resolution in any earth orbit to be flown by the Space Station or Space Shuttle. Readily measured are high levels of radiation including relativistic solar flares, natural and artificial trapped Van Allen Belt particles and cosmic rays. In its present configuration this system measures the following particle types and energy ranges.

- Electrons: 0.25 to 0.60, 0.70 to 0.80, 1.0 to 1.2, 1.5 to 1.8, 2.5 to 3.0, 4.3 to 4.8, and greater than 4.8 Mev.
- Protons: 10.5 to 15, 15 to 24, 24 to 40, 40 to 56, 56 to 80, 80 to 113, 113 to 150, 150 to 200, 200 to 320, and greater than 320 Mev.
- Alpha Particles: 11 to 30, 30 to 70, 70 to 113, 113 to 300, and greater than 300 Mev.
- Heavy Nuclei: Two groups with ranges in Tungsten of 0.25 to greater than 20 g/cm<sup>2</sup>.

The solid state directional telescope is designed to be mounted external to the space vehicle. It may be mounted close to the main body of the structure or on a boom. This system will provide the essential particle identification, energy discrimination, and pitch angle distributions for trapped particles, as well as solar flare and cosmic ray particle fluxes required for evaluation by

# TYPICAL OMNIDIRECTIONAL HIGH ENERGY ELECTRON, PROTON, AND ALPHA PARTICLE SPECTROMETER SENSORS

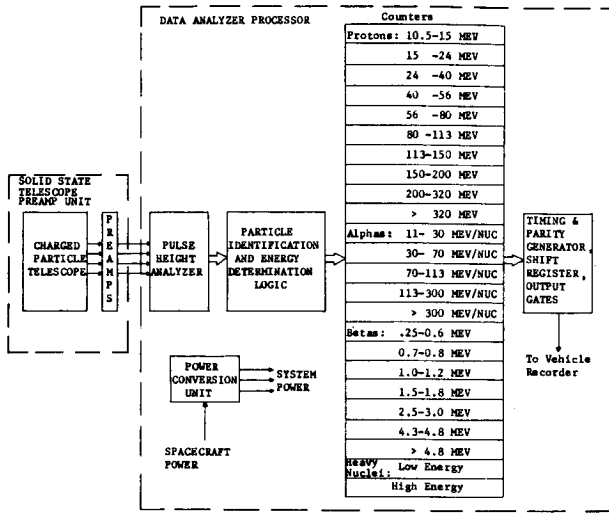
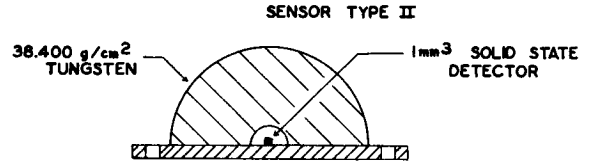
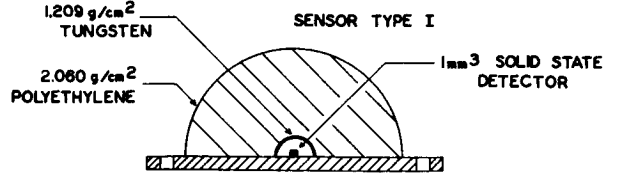

Figure 4. Directional Multicharged Particle Spectrometer System Block Diagram.



Figures 5 and 6.

on-board or ground based computers to provide internal dose data or radiation hazard data during extra vehicular activity.

In addition to measurements of the directional properties of space radiations, it is required that the omnidirectional energy spectra and fluxes of particles be well known to allow for a complete evaluation of the operational hazards. The omnidirectional spectrometer has been flown extensively in the past decade to measure the earth's Van Allen Belt radiations. The authors propose that at least one omnidirectional spectrometer system be flown on the Space Platform. Two basic systems have been designed and either may be used depending on the orbit flown. One omnidirectional system employs  $1\text{mm}^3$  or  $2\text{mm}^3$  solid state detectors shielded by hemispheres of varying thickness to provide the desired energy cutoff. A minimum of eight (8) individual sensors varying in thickness from  $0.112\text{ g/cm}^2$  to  $50\text{ g/cm}^2$  will define the spectral range of interest. Typical sensors for this omnidirectional system are shown in Figures 5 and 6. The electronic block diagram for the omnidirectional system is displayed in Figure 7. This system has been successfully breadboarded in the laboratory and employs the best available state of the art integrated microcircuits throughout. The energy and particle ranges measured by this spectrometer are:

- Electrons: Five Energy Levels: 0.37 to 1.0, 1.0 to 2.2, 2.2 to 4.0, 4.0 to 9.5, and greater than 9.5 Mev.
- Protons: Eight Energy Levels: 10 to 20, 20 to 34, 34 to 50, 50 to 72, 72 to 120, 120 to 170, 170 to 200, and greater than 200 Mev.
- Alpha Particles: Eight Energy Levels: 34 to 75, 75 to 125, 125 to 190, 190 to 275, 275 to 470, 470 to 600, 600 to 1000, and greater than 1000 Mev.

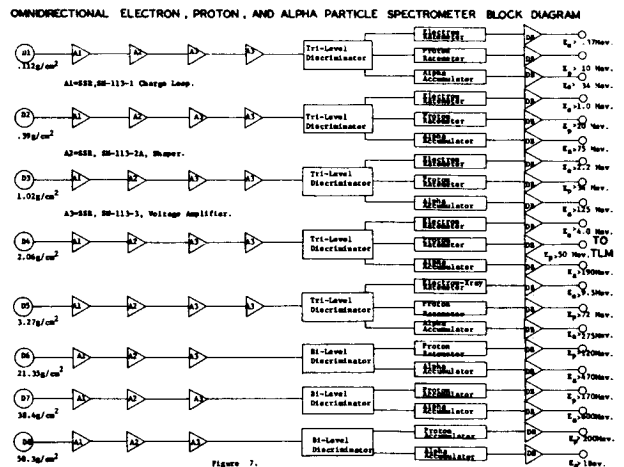

Figure 7.

## OMNIDIRECTIONAL ELECTRON SPECTROMETER SENSOR

This omnidirectional spectrometer functions well in the presence of relatively high fluxes of particles due to the small geometric factors of the sensors. If the expected fluxes of particles are low, sensors such as shown in Figure 8 after a design proposed in Ref. 19, would be more suitable. This instrument employs either 0.5 cm<sup>2</sup> or 1 cm<sup>2</sup>, 2000 micron fully depleted silicon detectors instead of the previously described 1mm<sup>2</sup> or 2mm<sup>2</sup> detectors and allows for a much larger geometric factor when low particle fluxes are encountered. The electron sensor for this system employs 217 small radial collimators in the shielding material to prevent electron saturation. Comparative weights and dimensions of the two systems are approximately the same. The omnidirectional spectral range measured by this spectrometer is also the same as previously described. If a hemispherical shield design is employed great care must be taken to insure that the sensors are mounted on plates whose thickness over the 2π solid angle at the backside considerably exceeds the thickness of the sensor hemispherical shielding. If a hemispherical design is flown, it is likely to be hard-mounted to the external of the spacecraft where the primary structure shielding can be taken advantage of on the backsides of the detectors. An alternative system would be the full spherical shields over the sensors as shown in Figures 9 and 10. These may be boom mounted so that a full 4π steradian instead of a 2π steradian measurement can be conducted. Where the spacecraft shielding is very thin, the heavier 4π detectors might be also mounted directly to the spacecraft without notable effect on the shielding of the sensors. This eliminates difficulties encountered with mounting the heavier sensors on a boom.

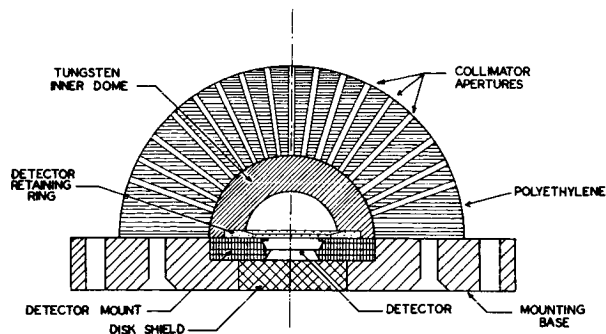

Figure 8b.

## SPHERICAL 4π OMNIDIRECTIONAL SENSOR

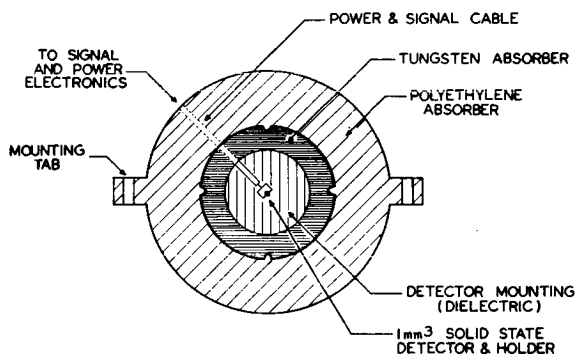

Figure 9.

## OMNIDIRECTIONAL PROTON SPECTROMETER SENSOR

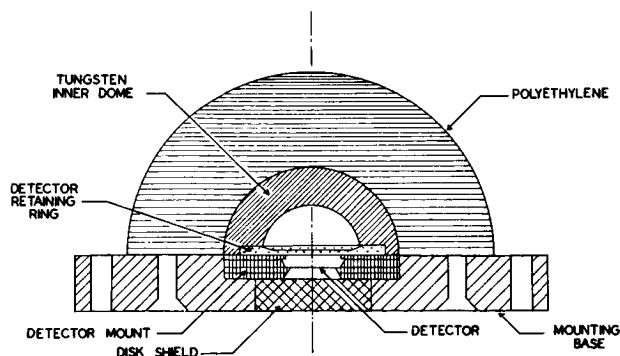

Figure 8a.

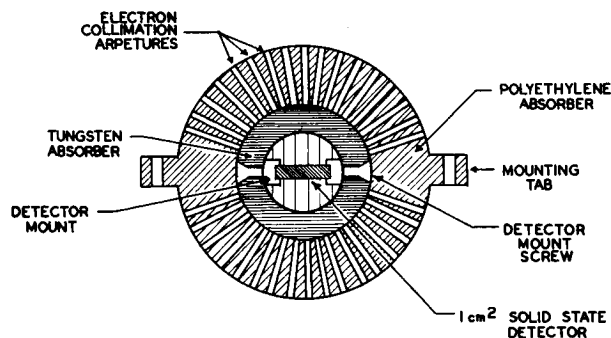

Figure 10. Spherical 4π Omnidirectional Electron Sensor

**PARTICLE WARNING SYSTEMS**

Since the Space Station may operate in solar flare environments and artificially injected electrons external on-board warning systems to alert the astronauts of the onset of such unexpected radiations, as well as insure the turn on of other required radiation monitoring instruments will be very important. Such a warning system would of necessity have two separate functions: 1) to detect the presence of energetic ( $E > 30$  Mev) protons in the absence of significant high energy ( $E > 2$  Mev) electrons and 2) detect appreciable increases in the electron fluxes in the earth's Van Allen Belts over the quiescent or natural background levels. Figure 11 indicates a conceptual solar flare and artificial electron enhancement detection system for use on the space station. This system as shown in Figure 11 has separate sensors from the omnidirectional spectrometer. However, the cost of the instrument could be greatly reduced by employing several of the lower energy omnidirectional charged particle spectrometer sensors previously described with a separate electronics system.

Large time of flight neutron spectrometers are under development by White, (Ref 20). This system uses liquid scintillation detectors in a time of flight arrangement as shown in Figure 12 to measure the very low primary solar and earth albedo neutron fluxes. This system is a satellite consisting of its own self contained signal conditioning and processing electronics. The use of this system on the Space Station would greatly increase the range and resolution of particle measurements. With this type of device it may be possible to predict in advance the arrival of solar protons by measuring the prompt neutron spectrum from the sun. This system is currently being developed for flight test this year and should be fully operational for possible

use in conjunction with the Space Station/Space Shuttle. This system could be attached to the Space Platform or flown in co-orbit with it. The neutron spectrometer would be incorporated as part of the solar flare warning system when the flux of neutrons reaches a pre-determined level. Such levels are as of this writing unknown. It is hoped that flights of this system before the Space Station/Space Shuttle will establish the solar neutron flux levels associated with proton events. If this is done, it is likely that the shape of the proton spectrum, as well as the particle flux emitted in a solar flare can be determined from measurements of the neutron fluxes in advance of the arrival of particles.

**INTERNAL SPACECRAFT DOSIMETRY AND SPECTROSCOPY**

**Portable Radiation Monitor**

The maximum allowable radiation doses to an astronaut for a 30-day mission have been defined for the Space Station (Ref, 21) and are presented in Table 2. Although the unavoidable mission-related doses to the astronauts are expected to be more than an order-of-magnitude below this, situations could arise in which one or more astronauts must receive doses near the acceptable maxima. Situations in this category include: extravehicular activity (EVA) during passage through the magnetic anomaly, repair or maintenance of equipment containing or in proximity to radiation sources (SNAP units, instrument radioisotopes, possibly a nuclear reactor), and solar flare proton events. In such cases, the radiation safety of the astronauts who assume the extra risk can only be assured by an "active" (i.e., read-out in real time) dosimeter carried on the astronaut's person. The criteria for such a device are as follows: 1) it must be self-contained, small, and portable, 2) total dose should be accumulated up to at least 100 rad, 3) dose-rate should be indicated so that the astronaut can take steps to minimize his exposure, 4) it should be accurate at low dose-rates, viz., so that it can record a dose of only 2.5 rad accumulated over a span of 24 hours (order of 0.1 rad/hour), 5) accuracy is critical at maximum dose-rates, viz., maximum dose of 75 rad reached in only a couple of minutes (order of 2000 rad/hour), 6) can measure surface doses ( $0.4 \text{ g/cm}^2$ ), 7) relays dose and dose-rate information to the central radiation monitoring system, and 8) measures the true radiation absorbed dose in a mixed field (protons, electrons, X- and gamma rays, neutrons, heavy charged particles).

TABLE 2

Radiation Exposure Limits\* for Space Station Crew (30-Day Mission) for Ancillary Reference Risks.

Depth	Dose
Skin (0.01 Cm)	75 REM
Eye (0.3 Cm)	37 REM
Marrow (5.00 Cm)	25 REM

\*See Reference 21.

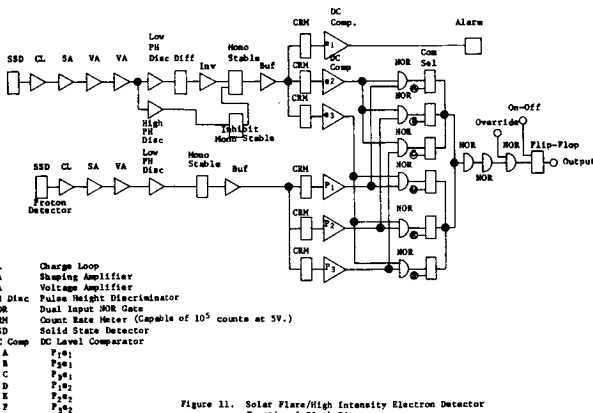

Figure 11. Solar Flare/High Intensity Electron Detector Functional Block Diagram

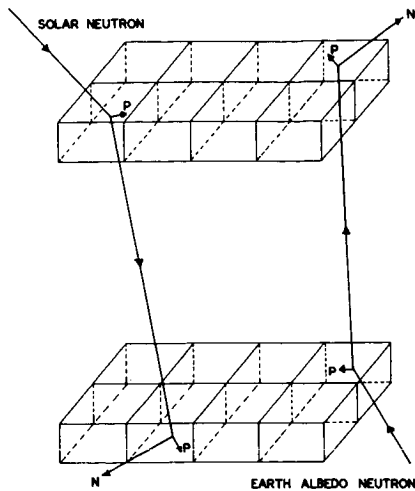

Figure 12. Large Time of Flight Neutron Spectrometer

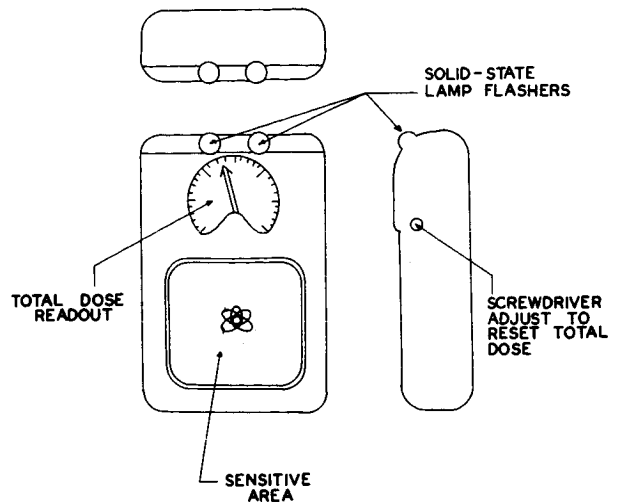

Figure 13. Astronaut Radiation Monitoring Instrument (ARMI).

To satisfy the above requirements, an Astronaut Radiation Monitor Instrument (ARMI) has been designed using presently available technology and techniques.

The device is similar in size, weight, and basic operating principle to the Personnel Radiation Dosimeter (PRD) used on Apollo flights (Ref 22) but incorporates several improvements and added features, including advanced circuitry, better collection geometry for the ionization chamber sensor, human-engineered total dose read-out, dose-rate indication, and telemetered output. The ARMI device is portrayed in Figure 13. It is intended to be small and streamlined to easily be accommodated in a pocket in the astronaut's spacesuit or underwear garment. At the same time, it is large enough to be easily held and manipulated with a gloved hand. Accumulated dose is read out to the astronaut via a meter having a pseudo-logarithmic scale divided into three color-coded sections: green, 0 to 1 rad; yellow, 1 to 10 rad; red, 10 to 200 rad. The radiation level is indicated by two solid-state lamps whose flash frequencies are directly proportional to dose-rate. Two flashers extend the observable dose-rate range by having one lamp flash at only one-tenth the rate of the other. Thus, at the upper dose-rate limit of 3,600 rad/hour, one lamp will pulsate at 10 pulses/second while the other lamp appears fully on at 100 pulses/second. On the other hand, at a lower dose-rate, say 36 rad/hour, the lamps will flash at rates of one-tenth and one pulse/second, respectively. Such indications are sufficient to enable the astronaut to minimize his exposure through adjustment of location, position, and/or shadow shielding. Monitoring of the astronaut's accumulated dose by other crew members and by ground control is accomplished by transmitting a low-power pulse from the ARMI to suitably-located receivers in the Space Station each time another 0.01 rad dose has been accumulated. Since several ARMI's may be in use simultaneously, the pulse from each unit will be uniquely coded in waveform for identification. Received pulses are then processed at the central radiation safety monitoring subsystem and accumulated dose information stored and

displayed for each ARMI in operation. The subsystem also will contain computing circuitry for determining dose-rate by measuring the time between successive 0.01 rad pulses. It also will compute and display the remaining permissible exposure time from the ARMI accumulated dose and dose-rate information plus a maximum permissible dose manually entered by the radiation safety officer.

The radiation-sensing element in the ARMI is a parallel-plate tissue-equivalent ionization chamber whose gas volume is shielded from one face of the instrument by only 0.4 g/cm<sup>2</sup> of material (outside housing plus one electrode). The parallel-plate geometry and small interelectrode gap allows a collection efficiency of over 95% in a field of 3,000 rad/hour with only a 10 V bias. The ionization current from the chamber is integrated by an electrometer circuit which operates in the "recycling coulometer" mode. Figure 14, is the block diagram outline of the circuit operation. The circuit is accurate over 4 1/2 decades of dose-rate, covering 0.1 to 3,000 rad/hour. All circuitry is of the low-voltage, micropower type recently developed for battery-powered instruments. The total dose-readout is a mechanically-advanced pointer, so that no standby power is required to maintain a reading. This, the chief power drain occurs during each recycling pulse, when the pulse must be flashed and transmitted. Sufficient long-life mercury batteries are sealed into the unit to provide four months of operating life. Thus, the ARMI is always "ON" and alert. It is not required that the astronaut activate a switch for its use, although if desired, the mechanical pointer can be reset to zero using a screwdriver adjustment. This allows the device to be used repeatedly by different astronauts.

#### Ultra-Sensitive Dosimeter

A compact (six-inch diameter) tissue-equivalent dosimeter has recently been developed (Ref. 23) for measurement of dose-rates below 1 rad/hour, with sensitivity down into the tens of microrad/hour. Such a dosimeter could serve as an accurate monitor of cosmic ray doses and inside levels of penetrating Van Allen Belt protons and electron bremsstrahlung. This instrument is light-weight, low-power, and fully flight-qualified.

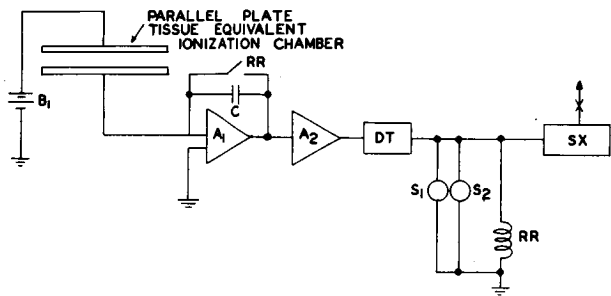

Figure 14. Electronic Block Diagram of the Astronaut Radiation Monitoring Instrument .

### Determining the Quality Factor

Assessment of radiation hazard to an astronaut requires knowledge not only of the absorbed dose, but as well as the time course of delivery, the distribution of dose throughout the body (especially as pertains to the gastro-intestinal and blood forming organs), and the specific ionizing power (linear energy transfer, LET) of the radiation. Proper allowance for all of the above factors is, in itself, an exceedingly difficult task. The physical measurements alone are quite formidable in the space environment. Indeed, due to the many uncertainties involved, the best policy remains to prevent all avoidable exposures to ionizing radiation. Nonetheless, as pointed out previously, some exposure is unavoidable, and in addition, emergency actions may require additional exposures. Active and passive dosimetry and radiation monitoring systems are mandatory. The full evaluation of the effect of an exposure likewise requires data on the depth-dose distribution and LET spectra. Ideally, these would be measured on-board, during exposure. This is very impractical, however, since depth-dose distributions require large phantoms containing

multiple dosimeters and no space-qualified instruments have as yet been flown for extended missions in space for measuring the LET spectra in mixed radiation fields. Concerning the latter problem, several instruments may hold promise for providing at least partial solutions to the LET problem: 1) the AFWL has recently developed a LET spectrometer for measuring proton and alpha LET spectra (Skylab Experiment D008), 2) the Rossi spherical proportional counter (Ref. 24) has been ruggedized, sealed, and flown with some success on high-altitude aircraft (Ref. 25), and 3) a multiplying ionization chamber with electronic analysis of the mean square fluctuation of output has been demonstrated (Ref. 26) for semi-quantitative determination of quality factor due to LET differences in mixed neutron-gamma ray fields.

Two additional combination dose and linear energy transfer spectrometer sensors have considerable promise for flight internal to the Space Platform. One system consists of a triaxis solid state detector telescope arrangement to measure the lower energy (higher LET components) of radiation entering the Space Station. The other system consists of thin scintillating tissue equivalent plastic plates less than 25 microns thick or small less 100 micron diameter spheres to measure the linear energy transfer spectrum as well as the dose rate received internal to the spacecraft.

The charged particle telescope shown in Figure 15 consists of four solid state detectors arranged to accept protons, alpha particles, and other multi-charged heavily ionizing particles. The system employs a thin, less than 20 micron, planar dE/dX detector and a 0.5 cm stacked silicon surface barrier detector. An annular detector and a 2000 micron totally depleted surface barrier detector are included to perform system anticoincidence. The electronic block schematic for this system is displayed in Figure 16. The solid state spectrometer measures particles with dE/dX from 3.5 to 100 Kev/micron. The deployment of this system in a tri-axis arrangement will provide an average or omnidirectional LET spectrum interior to the spacecraft. However, spectral data are limited to charged particles. We would propose in the interest of cost that this system be made semi-portable for use in any desired location in the spacecraft. The sensor could be attached to one of a number of hard-mounted inputs at various station locations and the signals processed by a central electronics system and relayed to ground and/or on-board computers for analysis and display.

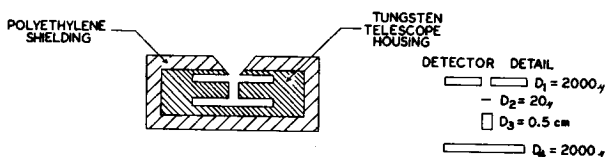

SOLID STATE DETECTOR LET SENSOR

Figure 15.



4 DETECTOR SOLID STATE LINEAR ENERGY TRANSFER (LET) SYSTEM

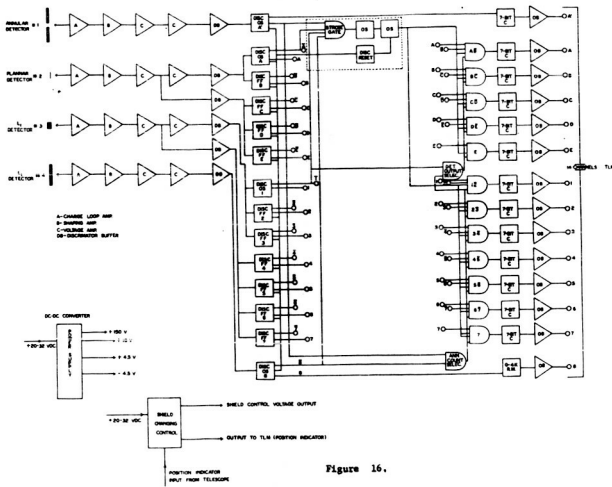

Figure 16.

The scintillating dose system has been developed and flown (Ref 27). It consists of either of two basic sensors. One sensor, Figure 17, employs a less than 25 micron NE-102 scintillating plate to measure the  $dE/dX$  of all particles producing ionization in the plate. This sensor can be used in either a  $2\pi$  or highly collimated shield to provide omnidirectional or directional data on the radiation received by the crew. The other sensor employs small, less than 100 micron, spheres to provide the desired LET measurements. This latter system can also be either a directional or omnidirectional device depending on the degree of collimation chosen around the sensor. This system can (as suggested by Ref 26) be employed to measure cellular hit frequency to provide additional radiobiological data of interest to the crew and biological experiments and on-board systems. The two scintillating systems share common, signal conditioning electronics shown in Figure 18. Either of the microscintillating LET systems can have semiportable sensors for multi-

location measurements. LET measurements are made in eleven channels from .22 Kev/micron to greater than 130 Kev/micron. This range could be easily extended on the high end by minor electrical modifications to the system. The microscintillators are by virtue of their tissue equivalency excellent mixed field detectors but lack the excellent charged particle pulse resolution of the previous solid state detector system.

As an alternative to considering the inclusion of phantoms or LET spectrometers, it may be sufficient for protection purposes to conduct suitable studies of these factors on the ground. The radiation fields from the on-board radiation sources can be characterized very thoroughly by appropriate ground studies. Space radiation is presently well understood qualitatively, which places limits on possible depth-dose and LET distributions. By incorporating results of the on-board radiation environment spectrometers (omnidirectional and unidirectional) as previously described, it may be possible to quite satisfactorily estimate quality factors directly from a knowledge of the type of exposure and measured level in rad.

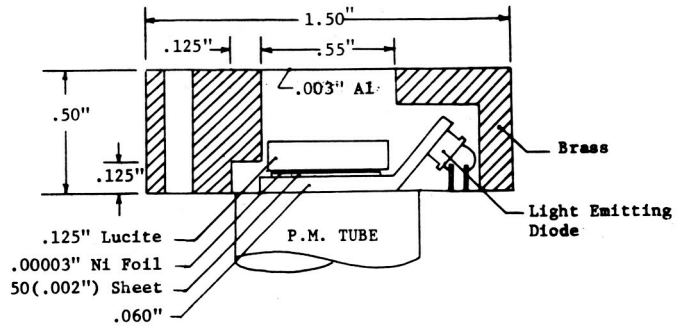

Figure 17. Thin Plastic Scintillating Plate Linear Energy Spectrometer Sensor.

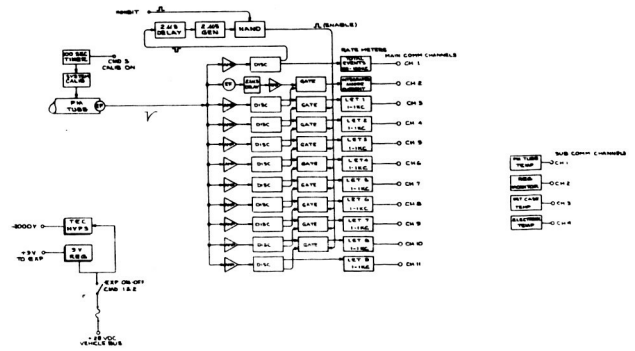

Figure 18. Microscintillator LET Electronic Block Diagram

PASSIVE DOSIMETRY SYSTEMS

Thermoluminescent Dosimetry Space Package

The need for a space radiation dosimeter which would be sensitive to charged particle radiations and also be responsive to thermal and fast neutrons has been the goal of scientific investigators for the past decade. New packaging techniques and greater sophistication of electronic instrumentation have increased the probability of securing a dosimeter with required sensitivity and adequate energy response. The ideal dosimeter is suitably accurate over a wide neutron energy spectrum and at the same time responsive to radiations such as gamma, high energy betas, protons, alphas, and X-rays of various energies.

If this dosimeter is to be utilized in the space program, additional points of interest must be considered. This instrument is rugged but light in weight, has no sharp edges or protruding connectors, and is small enough in size to fit comfortably into a special pocket on the astronaut's space suit. Astronaut identification and calendar date coding during readout are necessities for accurate data storage. All the above have been incorporated into the TLD system, Figure 19, which is proposed as a bio-radiation space package which meets the requirements for extended durations of planned space missions.

The TLD Space Package contains either two or three envelopes made of borosilicate glass. The filaments are nichrome ribbon which are finished and spot welded to the heating electrodes. The filament and TLD rough finishes, combined with the retainer clip, provide a large resistance to the TLD chip (Lithium fluoride bars). The glass envelopes shown in Figure 19 may be as small as 5/16" in diameter and 3/4" in length, which makes the complete dosimeter package less than 1 1/2" x 2" x 3/4". The filaments and identification code terminals are flush mounted receptacles as shown in the single glass envelope dosimeter, Figure 20.

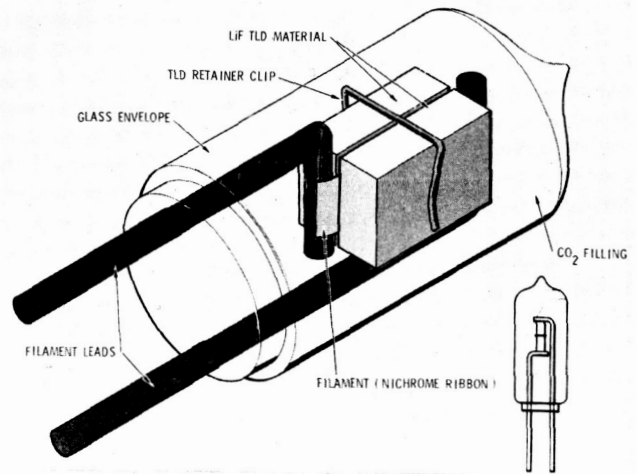

LITHIUM FLUORIDE THERMOLUMINESCENT DOSIMETER

Figure 20.

During extended space flights such as those in conjunction with the use of a Space Platform, data processing readout and storage capability necessitates an integrated system as indicated by Figure 21. By use of the bio-radiation packet and on-board readout system, the irradiation exposures

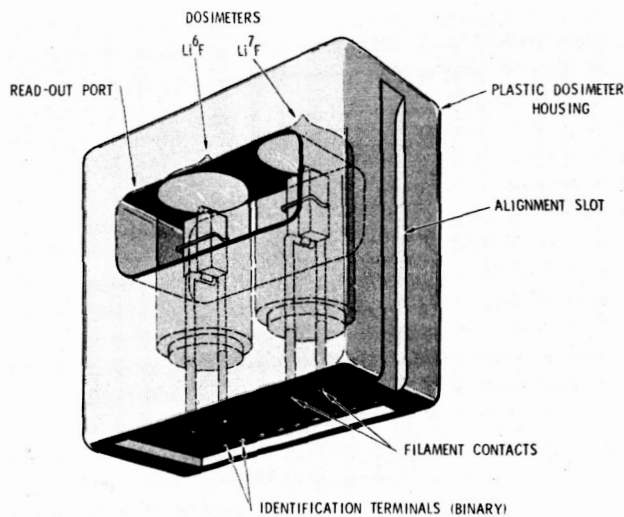

THERMOLUMINESCENT DOSIMETER SPACE PACKAGE

Figure 19.

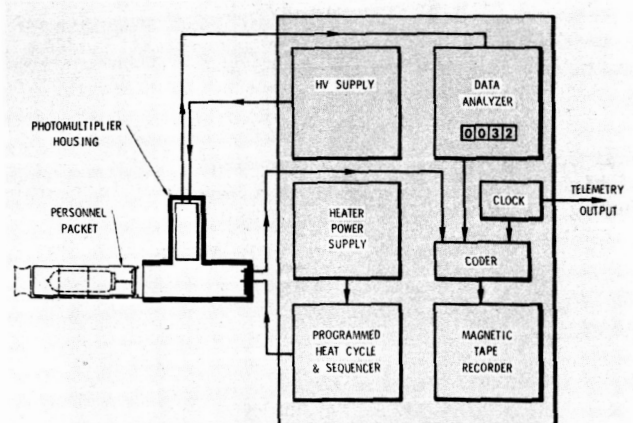

DATA PROCESSING READOUT AND STORAGE

Figure 21.

caused by any of the anticipated sources can be automatically calculated, visually read out, recorded, dated, and personally coded for each astronaut by the identification coder. The Programmed Heat Cycle and Sequencer will provide the astronauts with a newly activated, ready to use dosimeter capable of measuring all expected radiation exposures.

Responses from both thermal and fast neutrons have been studied by E. Tochilin and et. al., (Ref 28). Since the  ${}^6\text{LiF}$  has an extremely high cross section for thermal neutrons (945 barns) and  ${}^7\text{LiF}$  has a negligible cross section, one can measure simultaneously gamma and neutron exposures. (Ref 29) This dosimeter functions as a satisfactory system since the TLD's have a response that is relatively independent of storage time (at cabin or crew area temperature) between exposure and readout. The accuracy for dose determination is greater than 93%. Additional dosimeters contained within 5 centimeter thick tissue equivalent shields could be placed as monitors throughout the work area such that data need not be extrapolated as one compares read out parameters with the guidelines expressed by the Radiobiological Advisory Panel Committee on Space Medicine 1970 (Ref 30).

#### Foil Activation Counting With A Liquid Scintillator

Foil activation analyses for determining both neutron energies and neutron fluxes as described by H. M. Murphy (Ref 30) have been standard laboratory procedures for the past two decades. However, during the recent years great advancements have been made in the equipment and instrumentation relative to scintillation counters. Since certain metallic foils are responsive to a specific neutron energy range, an array of foils is used to detect the energies of interest. Two methods for counting are proposed; first, the foils may be returned following a space flight and counted as indicated above in ground based laboratories; or secondly, liquid scintillation counting vials could be fabricated prior to flight with the fluors plus foils which had been sealed and prepared for counting. As the foils are exposed to an unknown neutron flux they are read out immediately to give not only an integrated dose but also dose rate. The latter assumes capability for counting in a space laboratory or modification of existing experiments to accommodate such samples by vial exchange mechanisms activated in the event of a solar flare, in maintenance periods should a nuclear reactor malfunction, or for extra-vehicular activities during the passes near or through the magnetic anomalies (especially if high altitude nuclear detonations were initiated during the space flight). Having the scintillation counting vials prepared prior to launch has one great advantage over the returning of foils to ground based laboratories for counting since one can register the maximum number of counts from the activation process before they have had a chance to decay. Computer programs will have to be a part of the readout system to subtract the decay events such that new exposures may be expressed and current dose rates displayed on the visual screen. Generally, after the activated foil has decayed greater than five half lives, counting efficiencies and statistics are extremely low.

Rather than the use of a liquid fluor in the scintillation vial one may substitute a solid scintillator and in this way give more "ruggedness" to the system. However, at this time, the liquid scintillation process appears to be the most promising.

#### Modification of Discharge Ionization Chamber

With the increased demand for biomedical instrumentation and space suit complexity, one strives to reduce the size and weight for the essential items which are proposed to be contained on or within the astronaut's space suit or working garments. The pocket type dosimeter, Figure 22, has been modified to 1/3 its original length and weight without loss of accuracy. A readout system is proposed to be incorporated into the bench type console unit within the space laboratory such that the astronauts will have access to the reader on periodic checks. Since the reader system will be a necessity for radiation exposure determination, a record of this information will be automatically stored on tape with a date and astronaut identifier posted during readout. Two dosimeters of this type should be included within the space suit at all times. The combined size of coupling two of the modified dosimeters would be smaller than one of the present units. The only changes in design for the modified dosimeter are the removal of the optics and placing them in the console readout system with the coding and clock mechanisms. The sensitivity and maximum accumulated dose indicated by the readout system are comparable to the presently used dosimeter which is designed for maximum full scale readings to match the mission profile.

Using the same reader and charger system, the astronauts have similar dosimeter cartridges to measure not only gamma plus faster neutrons but also units to determine thermal neutron exposures or gamma plus X-ray exposures. The feature which permits differentiation among types of radiation is the wall material of which the ionization chamber is made. For example, to develop a dosimeter which is insensitive to neutrons but sensitive to gammas, one would include an ionization chamber wall material in which the elemental hydrogen content is less than two percent. The insulating material surrounding the ionization chamber is also to be nonhydrogenous. The Skylab Pocket Type Dosimeters have a full scale reading of 5 rads but this may be redesigned to read 25 rads, 50 rads or higher if required.

By including the two bio-radiation type dosimeters (TLD and small ionization chamber) plus the on-board liquid scintillation counting system for neutron dose analyses, one has many of the parameters needed to calculate not only the radiation absorbed dose in man but also valuable data to assess radiation effects on other spacecraft systems.

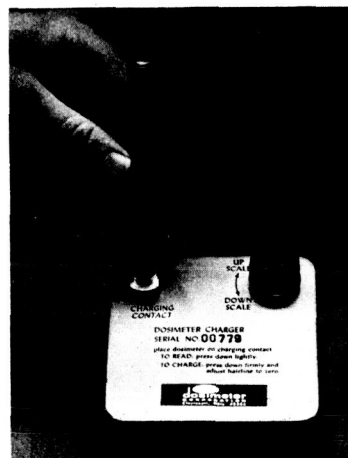

Figure 22. Discharge Ionization Chamber and Charger

## REFERENCES

1. Hess, W.N., *The Radiation Belts and Magnetosphere*, Bliesdell Publishing Co. Waltham, Mass., 1968.
2. O'Brien, B.J., *Review of Studies of Trapped Radiation with Satellite Bourne Apparatus*, *Space Science Reviews* (C. DeJager ed.), Reidel Publishing Co., Dordrecht, Holland, 415-418, 1962.
3. White, R.S., *The Earth's Radiation Belts*, *Physics Today*, 19: 25-38, 1966.
4. McIlwain, C.E., *The Radiation Belts, Natural and Artificial*, *Science*, 142: 355-361, 1963.
5. Fillius, R.W., *Trapped Protons of the Inner Radiation Belt*, *Journal of Geophysical Research*, 71: 97-123, 1966.
6. Vette, J.I., *Models of the Trapped Radiation Environment, Volume I, Inner Zone Protons and Electrons, Volume II, Inner and Outer Zone Electrons*, NASA SP-3024, 1966.
7. Webber, W.R., *Time Variations of Low Rigidity Cosmic Rays During the Sunspot Cycle*, *Progress in Elementary Particle and Cosmic Ray Physics*, Vol. 6, (Wilson and Wouthuysen editors.) North Holland Publishing Co., Amsterdam, 1962.
8. Carmichael, H., *High Energy Solar Particle Events*, *Space Science Reviews*, 1: 28-61, 1962.
9. Frier, P.S. and Webber, W.R., *Exponential Rigidity Spectrums for Solar Flare Cosmic Rays*, *Journal of Geophysical Research*, 68: 1605 - 1629, 1963.
10. Linsley, J., *Evidence for a Primary Cosmic Ray Particle with Energy of  $10^{20}$  ev*, *Physical Review Letters*, 10: 146-148, 1963.
11. Ormes, J.F. and Webber, W.R., *Measurements of Primary Proton and Helium Spectra and Their Modulations Using Balloon Borne Cerenkov Scintillation Counter*, *Proceedings of the Ninth International Conference on Cosmic Rays*, London, 1965.
12. Winckler, J.R., *Primary Cosmic Rays*, *Radiation Research*, 14: 521-539, 1960.
13. Neher, H.V., and Anderson, H.R., *Cosmic Rays at Balloon Altitudes and the Solar Cycle*, *Journal of Geophysical Research*, 67: 1309 - 1313, 1962.
14. West, H.I., et al., *Spectra and Fluxes of Electrons Trapped in the Earth's Magnetic Field Following Recent High Altitude Nuclear Bursts*, AFCRL Report, *Interm Results of Radiation Measurements from Air Force Satellite 1962 BK 1963*.
15. Bostrom, C.O., and Williams, D.J., *Time Decay of the Artificial Radiation Belts*, *Journal of Geophysical Research*, 70: 240-242, 1965.
16. Wiley, R., *Private Communications*, 1971, *Calculations from Air Force Weapons Laboratory High Altitude Weapons Particle Injection Codes*.
17. Hopkins, K., *Private Communications*, 1971, *Computations from Air Force Weapons Laboratory Space Radiation Transport Codes*.
18. Rinehart, M., *Solid State Space Radiation Monitoring System, Final Report to the Air Force Weapons Laboratory, Kirtland Air Force Base, New Mexico, Philco Ford Corp., Under Contract AF29600-3498*, 1965.
19. Burton, B.S., *Design and Construction of an Electron Proton Spectrometer*, *Air Force Weapons Laboratory Technical Report*, TR-65-186, August 1966.
20. White, R.S., *Design of a Large High Resolution Time of Flight Spectrometer to Measure Neutrons*, *University of California at Riverside Final Report to the Air Force Weapons Laboratory under Contract F29601-69-C-0029*, 1969.
21. *Radiation Protection Guides and Constraints for Space Mission and Vehicle Design Studies Involving Nuclear Systems*, *National Academy of Sciences Special Publication*, 1970.

22. Warren, C.S., and Lill, J.C., et. al., Radiation Dosimetry on the Gemini and Apollo Missions, Journal of Spacecraft, Vol. 5, p-207, 1968.
23. Lay, L.B., Private Communications, AVCO Corporation, Tulsa, 1971.
24. Rossi, H.H., and Rosenzweig, W., Radiology, Vol. 64, p-404, 1955.
25. Philbrick, R., Air Force Weapons Laboratory, Private Communications, 1971.
26. Bengtsson, L.G., Estimation of Dose Equivalent from Proportional Counter Current Variation, Annual Report on Research Project NYO-2740-6, 1969.
27. Chapman, M.C., et. al., Development of a Cellular Absorbed Dose Spectrometer, Air Force Weapons Laboratory Technical Report No. AFWL-TR-69-76, Kirtland AFB, New Mexico, December 1969.
28. Wingate, C.L., and Tochlin, E., and Goldstein, N., Responses of Lithium Fluoride to Neutrons and Charged Particles, Luminescence Dosimetry, USAEC, Oak Ridge, Tennessee, p-421-434, 1967.
29. Tochlin, E., and Shumway, B., Dosimetry of Neutron and Mixed Neutron Gamma Fields, Radiation Dosimetry, Vol. 3, Chapter 22, Academic Press Inc., New York, 1969.
30. Radiation Protection Guides and Constraints for Space Mission and Vehicle Design Studies Involving Nuclear Systems, Space Science Board, National Academy of Sciences, 1970.
31. Murphy, H.M., Summary of Neutron and Gamma Dosimetry Techniques, Air Force Weapons Laboratory Technical Report AFWL-TR-66-111, Kirtland AFB, New Mexico, 1967.